



BIN SITE SYSTEM



Operators Manual



INTRODUCTION

Thank you for choosing USC, LLC for your equipment needs. We appreciate your business and will work diligently to ensure that you are satisfied with your choice.

OVERVIEW

The purpose of this manual is to provide you with the basic information needed to operate and maintain the USC Bin Site System. It does not hold USC, LLC liable for any accidents or injuries that may occur.

OPERATOR RESPONSIBILITIES

As the purchaser/owner/operator of this equipment and control system, you have an obligation to install, operate, and maintain the equipment in a manner that minimizes the exposure of people in your care to any potential hazards inherent in using this equipment. It is critical that the owner of this equipment:

- Has a clear and documented understanding of the process this machine is being used in and of any resulting hazards or special requirements arising from this specific application.
- Allow only properly trained and instructed personnel to install, operate, or service this equipment.
- Maintain a comprehensive safety program involving all who work with this machine and other associated process equipment.
- Establish clear areas of staff responsibility (e.g. operation, setup, sanitation, maintenance, and repairs).
- Provide all personnel with necessary safety equipment.
- Periodically inspect the equipment to insure that the doors, covers, guards, and safety devices are in place and functioning, that all safety instructions and warning labels are intact and legible, and that the equipment is in good working order.
- In addition to the operating instructions, observe and enforce the applicable legal and other binding regulations, national and local codes.

As the person with the most to gain or lose from working safely, it is important that you work responsibly and stay alert. By following a few simple rules, you can prevent an accident that could injure or kill you or a co-worker.

BIN SITE SYSTEM

- Disconnect, lockout, and tagout electrical and all other energy sources before inspecting, cleaning, servicing, repairing, or any other activity that would expose you to the hazards of electrical shock.
- Do not operate, clean, or service this equipment until you have read and understood the contents of this manual. If you do not understand the information in this manual, bring it to the attention of your supervisor, or call your local USC dealer for assistance.
- Any operator who is known or suspected to be under the influence of alcohol or drugs should not be allowed to operate the equipment.
- Understand and follow the safety practices required by your employer and this manual.
- **PAY ATTENTION** to what you and other personnel are doing and how these activities may affect your safety.
- **Failure to follow these instructions may result in serious personal injury or death.**

RECEIVING YOUR EQUIPMENT

As soon as the equipment is received, it should be carefully inspected to make certain that it has sustained no damage during shipment and that all items listed on the packing list are accounted for. If there is any damage or shortages, the purchaser must immediately notify your USC dealer. Ownership passes to purchaser when the unit leaves the USC, LLC. premises. The purchaser is responsible for unloading all components of the equipment.

Document the serial number of the machine for future reference. Below are pictures showing where the serial numbers are located.



*Bin Site Serial
Number*

BIN SITE PANEL SERIAL NUMBER: _____

TABLE OF CONTENTS

<u>Section</u>	<u>Contents</u>	<u>Page #</u>
Section A	Safety Instructions	5
Section B	Installation & Setup.....	12
Section C	Mechanical Operation	14
	System Overview	14
	Bin Slide Gates, Underbin Conveyor, & Scale Fill Conveyor..	16
	Weigh Hopper, Slide Gate & Scale Head.....	16
	Pro Box Hopper, Transfer Conveyor, & Diverter	17
	Underbin Conveyor Counter.....	17
Section D	Electrical Operation	18
	Main Screen	20
	H-O-A Screen.....	23
	Utilities Screen	26
	Security Screen	28
	Tools & Options Screen	30
Section E	Operation & Calibration	37
	Loading Seed Into Bins	37
	Setting The Seed Flow Rate	38
	Scale Fill Only	39
	Auto Treat	41
	Auto Bypass	44
	Treating Seed From Pro Boxes	46
	Reports.....	47
	Scale Fill Calibration.....	48
	Underbin Operation In Reverse Mode.....	49
	Printing & Uploading Reports	50
Section F	Troubleshooting & Alarms	57
	Troubleshooting	57
	System Alarms - Faults	59
	Paused Controlled Warning	61
	System Messages.....	62
Section G	Maintenance	63
Section H	Storage.....	68
Section I	Mechanical Drawings.....	71
Section J	Limited Warranty	75

SAFETY INSTRUCTIONS

SECTION A

Every year accidents in the work place maim, kill, and injure people. Although it may be impossible to prevent all accidents, with the right combination of training, operating practices, safety devices, and operator vigilance, the number of accidents can be significantly reduced. The purpose of this section is to educate equipment users about hazards, unsafe practices, and recommended hazard avoidance techniques.

SAFETY WORDS AND SYMBOLS

It is very important that operators and maintenance personnel understand the words and symbols that are used to communicate safety information. Safety words, their meaning and format, have been standardized for U.S. manufacturers and published by the American National Standards Institute (ANSI). The European Community (E.C.) has adopted a different format based on the International Standards Organization (I.S.O.) and applicable machinery directives. Both formats are presented below. Graphic symbols are not standardized, but most manufacturers will use some variation of the ones seen in this manual.



Indicates an imminently hazardous situation which, if not avoided, **will** result in death or serious injury.



Indicates a potentially hazardous situation which, if not avoided, **could** result in death or serious injury.



Indicates a potentially hazardous situation which, if not avoided, **may** result in minor or moderate injury and/or property damage.



Provides additional information that the operator needs to be aware of to avoid a potentially hazardous situation.



Mandatory Lockout Power Symbol. Disconnect, lockout, and tagout electrical and other energy sources before inspecting, cleaning, or performing maintenance on this panel.



International Safety Alert Symbol. The exclamation point (!) surrounded by a yellow triangle indicates that an injury hazard exists. However, it does not indicate the seriousness of potential injury. The exclamation point (!) is also used with the DANGER, WARNING, and CAUTION symbols so the potential injury is indicated.



Electrocution Hazard Symbol. This symbol indicates that an electrocution hazard exists. Serious injury or death could result from contacting high voltage.



International Electrocution Hazard. This symbol indicates that an electrocution hazard exists. Serious injury or death could result from contacting high voltage.



Mandatory Read Manual Action Symbol. (I.S.O. format)
This symbol instructs personnel to read the Operators Manual before servicing or operating the equipment.



Mandatory Read Manual Action Symbol. This symbol instructs personnel to read the Operators Manual before servicing or operating the equipment.

NOTICE

Notice is used to notify people of important installation, operation, or maintenance information which is not hazard related.

LOCKOUT / TAGOUT PROCEDURES

Lockout/Tagout is the placement of a lock/tag on an energy isolating device in accordance with an established procedure. When taking equipment out of service to perform maintenance or repair work, always follow the lockout/tagout procedures as outlined in ANSI Z344.1 and/or OSHA Standard 1910.147. This standard “requires employers to establish a program and utilize procedures for affixing appropriate lockout devices or tagout devices to energy isolating devices and to otherwise disable machines or equipment to prevent unexpected energizing, start-up, or release of stored energy in order to prevent injury to employees.”

EMERGENCY STOP



There is one Emergency Stop push buttons located on the Bin Site Control Panel. Actuators of emergency stop shall be colored RED. The background immediately around the device actuator shall be colored YELLOW. The actuator pushbutton-operated device shall be of the palm or mushroom head type.

CONTROLLED STOP

This is the stopping of machine motion by reducing the electrical command signal to 0 (zero) once the stop signal has been recognized.

HAZARD REVIEW

Electrocution Hazard



Electrocution accidents are most likely to occur during maintenance of the electrical system or when working on or near exposed high voltage wiring. This hazard does not exist when the electrical power has been disconnected, properly locked, and tagged out.

Automatic Start Hazard



This seed treating system is usually controlled by an automated system and may start without warning. Failure to properly disconnect, lockout, and tagout all energy sources of remotely controlled equipment creates a very hazardous situation and could cause injury or even death. PLEASE STAY CLEAR AND BE ALERT.



YOU are responsible for the **SAFE** operation and maintenance of your USC, LLC Bin Site System. **YOU** must ensure that you and anyone else who is going to operate, maintain, or work around the Bin Site System be familiar with the operating and maintenance procedures and related **SAFETY** information contained in this manual. This manual will take you step-by-step through your working day and alert you to good safety practices that should be adhered to while operating the bin site system.

Remember, **YOU** are the key to safety. Good safety practices not only protect you, but also the people around you. Make these practices a working part of your safety program. Be certain that **EVERYONE** operating this equipment is familiar with the recommended operating and maintenance procedures and follows all the safety precautions. Most accidents can be prevented. Do not risk injury or death by ignoring good safety practices.

- Bin Site System owners must give operating instructions to operators or employees before allowing them to operate the machine, and at least annually thereafter per OSHA (Occupational Safety and Health Administration) regulation 1928.57.
- The most important safety device on this equipment is a **SAFE** operator. It is the operator's responsibility to read and understand **ALL** Safety and Operating instructions in the manual and to follow them. All accidents can be avoided.
- A person who has not read and understood all operating and safety instructions is not qualified to operate the machine. An untrained operator exposes himself and bystanders to possible serious injury or death.
- Do not modify the equipment in any way. Unauthorized modification may impair the function and/or safety and could affect the life of the equipment.
- Think SAFETY! Work SAFELY!

GENERAL SAFETY

1. Read and understand the Operator's Manual and all safety signs before operating, maintaining, adjusting or unplugging the bin site system.
2. Only trained persons shall operate the bin site system. An untrained operator is not qualified to operate the machine.
3. Have a first-aid kit available for use should the need arise, and know how to use it.



4. Provide a fire extinguisher for use in case of an accident. Store in a highly visible place.
5. Do not allow children, spectators or bystanders within hazard area of machine.
6. Wear appropriate protective gear. This includes but is not limited to:



- A hard hat
- Protective shoes with slip resistant soles
- Protective goggles
- Heavy gloves
- Hearing protection
- Respirator or filter mask



7. Place all controls in neutral or off, stop motor, and wait for all moving parts to stop. Then disable power source before servicing, adjusting, repairing, or unplugging.
8. Review safety related items annually with all personnel who will be operating or maintaining the bin site system.



OPERATING SAFETY:

1. Read and understand the Operator's Manual and all safety signs before using.
2. Disconnect and disable electrical supply completely and wait for all moving parts to stop before servicing, adjusting, repairing or unplugging.
3. Clear the area of bystanders, especially children, before starting.
4. Be familiar with the machine hazard area. If anyone enters hazard area, shut down machine immediately. Clear the area before restarting.
5. Keep hands, feet, hair and clothing away from all moving and/or rotating parts.
6. Stay away from overhead obstructions and power lines during operation and transporting. Electrocution can occur without direct contact.
7. Do not operate machine when any guards are removed.
8. Inspect welds and repair if needed.

PLACEMENT SAFETY

1. Move only with the appropriate equipment
2. Stay away from overhead power lines when moving any components of the Bin Site System. Electrocutation can occur without direct contact.
3. Be familiar with machine hazard area. If anyone enters hazard areas, shut down machine immediately. Clear the area before restarting.
4. Operate the bin site system on level ground free of debris. Anchor the equipment to prevent tipping or upending.



Before placement of any equipment, be sure that ground is reasonably level. The equipment may topple or work improperly if the ground is too uneven, damaging the equipment and/or causing personal injury.

MAINTENANCE SAFETY

1. Review the Operator's Manual and all safety items before working with, maintaining or operating the bin site system.
2. Place all controls in neutral or off, stop motors, disable power source, and wait for all moving parts to stop before servicing, adjusting, repairing or unplugging.
3. Follow good shop practices:
Keep service area clean and dry.
Be sure electrical outlets and tools are properly grounded.
Use adequate light for the job at hand.
4. Keep hands, feet, hair and clothing away from all moving and/or rotating parts.
5. Clear the area of bystanders, especially children, when carrying out any maintenance and repairs or making any adjustments.
6. Before resuming work, install and secure all guards when maintenance work is completed.
7. Keep safety signs clean. Replace any sign that is damaged or not clearly visible.



SAFETY SIGNS

1. Keep safety signs clean and legible at all times.
2. Replace safety signs that are missing or have become illegible.
3. Replaced parts that displayed a safety sign should also display the current sign.
4. Safety signs are available from your Authorized Dealer.

How to Install Safety Signs:

- Be sure that the installation area is clean and dry.
- Be sure temperature is above 50°F (10°C).
- Decide on the exact position before you remove the backing paper.
- Remove the smallest portion of the split backing paper.
- Align the sign over the specified area and carefully press the small portion with the exposed sticky backing in place.
- Slowly peel back the remaining paper and carefully smooth the remaining portion of the sign in place.
- Small air pockets can be pierced with a pin and smoothed out using the piece of sign backing paper.



Located on the USC equipment you will find safety labels. Always be sure to read and follow all directions on the labels.



Guards provided with USC equipment are to remain in place during operation.

**SECTION
B**

INSTALLATION & SETUP



HIGH VOLTAGE ~ Always disconnect the power source before working on or near the control panel or lead wires.



HIGH VOLTAGE ~ Use insulated tools when making adjustments while the controls are under power.



Permanent installation may require additional electrical cords, liquid hose, and air lines, since each installation is unique.

SET-UP

The following steps outline the initial set-up of your USC Bin Site System:

1. Confirm all equipment has been received and then contact USC, LLC or your dealer to setup a time for an installation crew to install your Bin Site System.
2. A USC trained install crew will arrive on site and perform the necessary steps for installation of the equipment.



Based on your particular bin site system, some additional equipment may be required to install the bin site system (i.e. fork lift(s), crane, etc)



USC requires that all touch screen control panels be set up inside a building or in a covered structure to protect the machine from weathering.

3. Have a certified electrician provide power to the Bin Site System and wire in all necessary “customer supplied” wiring, including Ethernet cables as listed in your provided bin site schematics. Provide convenient shutdown switches and comply with local electrical codes. The USC Bin Site System must be connected to the same electrical requirements as specified in the main control panel on the power requirement tag and the electrical schematic shipped with the piece of equipment. This will power the entire USC bin site system.



4. Connect a dedicated analog phone line to the modem located in the top left portion of the control panel. This will allow USC remote access to the bin site system to help diagnose and fix problems that may arise.

*Analog Phone
Line Hooked Up
Here*



5. A service port located on the side of the main control panel will allow the operator to connect a printer and an Ethernet connection to the unit. The printer connection will allow the user to print reports directly from the reports screen.

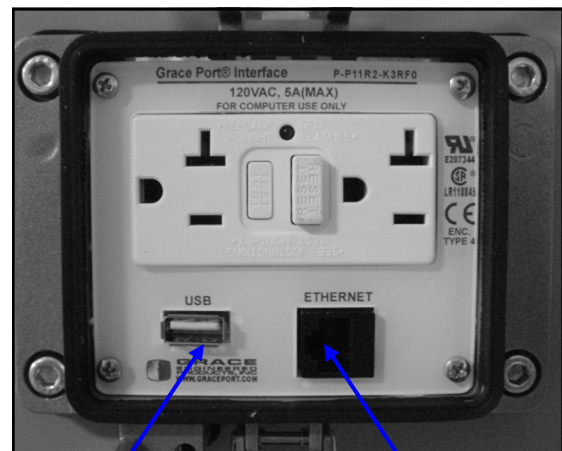

*Printer
Connection*

*Ethernet
Connection*

6. Supply approximately 100-110 psi of air pressure to the bottom of the solenoid group on the side of the bin site control panel. (right) It is required that this airline be ran in-line with a customer supplied air dryer to protect the air system from contamination.

7. Contact USC, LLC or your dealer to setup a startup and training session(s) before using your bin site system.

8. Have the scales calibrated by a state certified professional scale technician after the USC, LLC trained technician has performed a startup session on your site.

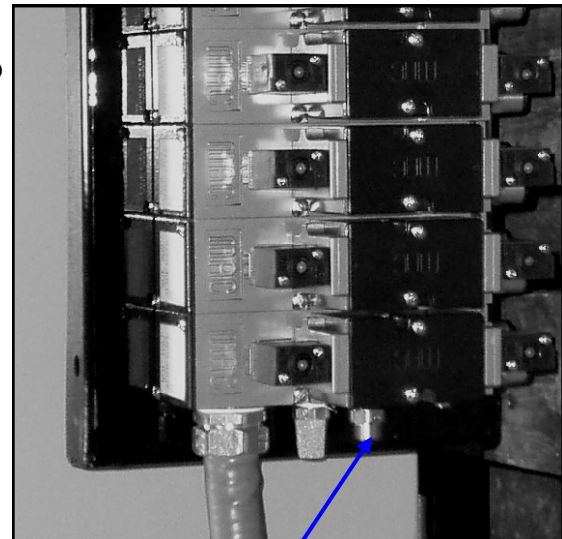

*Connect Air
Line Here*

SECTION
C

MECHANICAL OPERATION

SYSTEM OVERVIEW

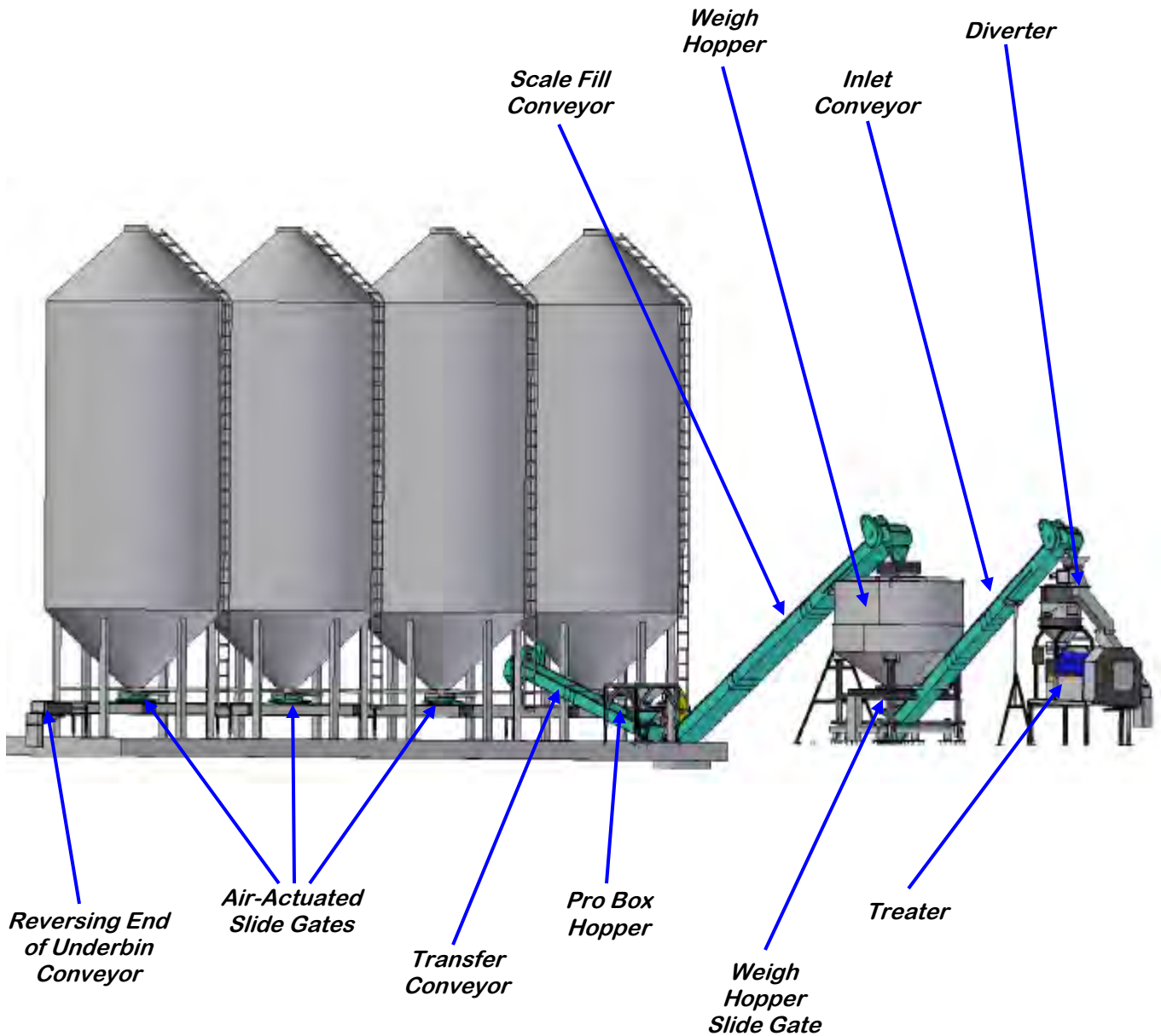

SYSTEM OVERVIEW

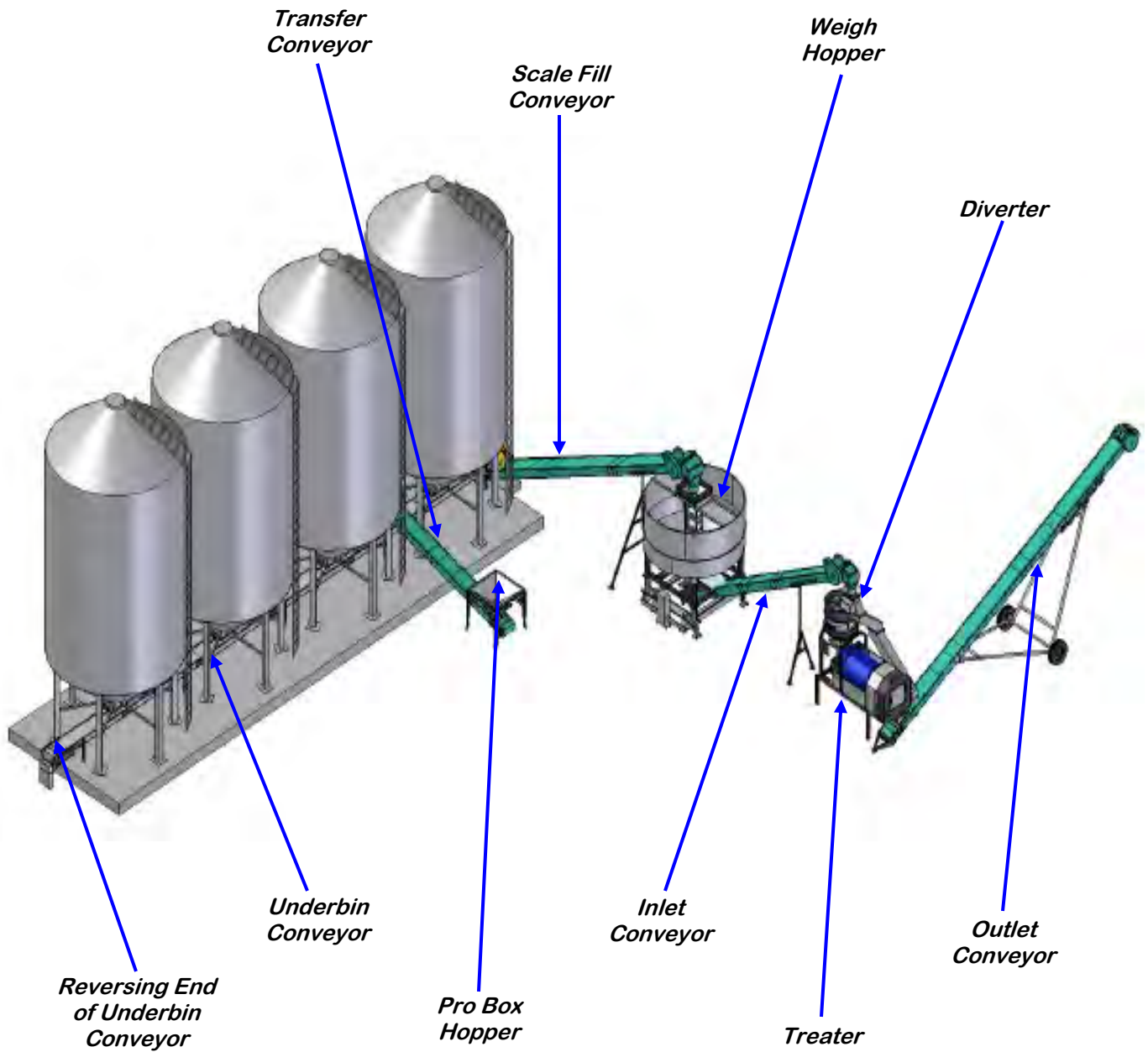

BIN SLIDE GATES

An air-actuated slide gate attaches to the bottom of each bin. The slide gate sits below the manual crank gate on the bin. The speed of seed passing through the gate is adjusted by moving the collar on the rod that exits out of the back of the bin slide gate. Moving the collar further away from the bin slide gate will allow the gate to open more and increase seed flow. Seed flow through the gate can also be adjusted via the manual gate on the bottom of the bin. It is recommended that the manual gate be opened to at least the half way point. The system calibrates seed flow through a timing mechanism that tells the air gate to close after a given amount of seed has passed through the gate. After each run of seed, the system will perform an automatic calibration that is bin specific. If the manual gate or the collar is adjusted, recalibration of the seed flow will need to be done (see page 48).

UNDERBIN CONVEYOR

The underbin conveyor sits directly below each air-actuated slide gate and transports seed forward to the scale fill conveyor. The underbin conveyor may also include an option so that it can run in reverse for clean out purposes. Seed is moved inside the underbin conveyor via a crescent belt. An adjustment for the tracking of this belt is located at both the head and tail section of the conveyor. The head section also includes a viewing window and the tail section has a removable cover to help with proper adjustment. An optional counter may also be located in the tail section of the underbin conveyor. The counter is used to verify that the conveyor is running without any slippage at the belt.

SCALE FILL CONVEYOR

The scale fill conveyor is a fixed conveyor that is used to transport seed from the discharge end of the underbin conveyor to the top of the weigh hopper. This conveyor's intake hopper will sit directly under the discharge portion of the underbin conveyor and the discharge end of the scale fill conveyor will be directly above the center of the weigh hopper. The scale fill conveyor is commonly used as the device that brings seed from outside of the treater building to the inside. In order for the weigh hopper to be legal for trade, the scale fill conveyor must not physically touch the weigh hopper.

WEIGH HOPPER, SLIDE GATE & SCALE HEAD

Once seed exits the discharge end of the scale fill conveyor, it will fall down into a fixed seed ladder that is located in the center of the weigh hopper. Seed will then come to rest above the slide gate as it waits to be weighed. The weigh hopper sits atop a scale assembly. The system uses a Cardinal series 205 scale head to display the current weight of the seed in the weigh hopper. The scale head communicates with the system via a Cat5e Ethernet cable. When the system finishes shutting down each of the conveyors, it will then look to the scale head to get the current weight of the seed in the weigh hopper for calibration purposes.

NOTICE

The Cardinal series 205 scale head will require calibration by a state certified calibration specialist in order for it to be legal for trade.

Located below the weigh hopper is an air-actuated slide gate. This slide gate has two magnetic sensors that are positioned to read whether or not the slide gate is currently in the open or close position. This is done to ensure an accurate scale reading will always be achieved. Directly below the air actuated slide gate is a manual gate that can be positioned to control the flow of seed from the weigh hopper.

PRO BOX HOPPER (optional)

The pro box hopper is an inverted pyramid shaped hopper that is used as a means of running seed straight from a pro box into the bin site system. This hopper may include an adjustable slide gate for metering the flow of seed and adjustable legs for changing the height of the hopper.

TRANSFER CONVEYOR (optional)

The transfer conveyor is the conveyor that connects the pro box hopper to the rest of the system. This conveyor is located so that its intake hopper is directly under the pro box hopper and its discharge end is either directly above the weigh hopper or is feeding into the underbin conveyor. This conveyor can be run in the “auto” mode or be run manually via the bin site H-O-A screen.

DIVERTER (optional)

The diverter is an air actuated gate that is typically located above the seed wheel. The diverter gate will sit in one of two positions: treat or bypass. When the gate is in the treat position, seed will flow into the treater to have chemical applied to it. When the gate is in the bypass position, seed will not enter the treater but instead will be carried away through a separate chute to a non-contaminated conveyor or holding device. The diverter can be manually actuated by pressing and holding the appropriate position button in the bin site H-O-A screen.

UNDERBIN CONVEYOR COUNTER (optional)

The underbin conveyor counter is an electronic device that is connected to a non-drive shaft on the underbin conveyor. This is usually the rear conveyor shaft. The counter sends an electrical signal to the bin site system whenever the shaft is spinning. That signal allows the bin site system to know that the belt on the underbin conveyor is traveling at the correct speed and that no slippage is occurring. This process allows the bin site system to perform a correct auto-calibration after each run of seed.

SECTION
D**ELECTRICAL OPERATION**

HIGH VOLTAGE ~ Always disconnect the power source before working on or near the control panel or lead wires.



HIGH VOLTAGE ~ Use insulated tools when making adjustments while the controls are under power.



AUTHORIZED PERSONNEL only shall work on the control panel. Never allow anyone who has not read and familiarized themselves with the owner's manual to open or work on the control panel.

This section provides a general overview and description of the operator controls for the Bin Site System.

General Panel Descriptions

This system consists of one panel:

- The Main Control Panel (MCP) is a 36 x 30 x 10 inch enclosure that contains all of the electrical control components as well as the HMI (Human/Machine Interface) touch screen. The air solenoid bank that controls all of the bin site system's air valves is located on the side of and hardwired to the MCP. The operator is able to control the entire system through the HMI. The MCP is connected to the scale head via an Ethernet cable. The MCP may be connected to the Treater MCP via an Ethernet cable, as well. If the bin site system is tied in with a PLC based treater, then the HMI will be located on the Treater MCP.

Main Control Panel

The following pages explain the function of the touch screen controls.

USC STARTUP SCREEN

This screen is the first screen the operator will see after the system receives power. Touch this screen to allow the operator to advance to the Main screen.



Main Screen Button Descriptions

1. Underbin Conveyor Reverse Indicator: (optional) Informs the operator that the underbin conveyor is currently running in reverse. This indicator will only be present if the bin site system has a reversible underbin conveyor.

2. Emergency Stop Indicator: This blinking display is activated when the system E-Stop button is activated.

3. Current Date and Time Display

4. Current Bin Info: Displays the bin information that has been entered into the currently selected bin. Includes seed type, seed variety, seeds/lb and inventory.

5. Diverter Indicator (optional): Informs the operator if the diverter is currently in the “treat” or “bypass” position. This indicator will only be present if the bin site system has a diverter.

6. Transfer Conveyor Motor Status Indicator (optional): Informs the operator if the transfer conveyor motor is “ON” or “OFF”. This indicator will only be present if the bin site system has an included transfer conveyor.

7. “H-O-A” (Hand-Off-Auto) Button: This button advances the operator to the “H-O-A” screen.

8. “UTILITIES” Button: This button advances the operator to the “Utilities” screen.

9. “TO BINS 5-8” Button (optional): This button advances the operator to the “Main” screen for bins 5-8. This button will only be available if the bin site system has more than 6 bins.

10. Treater Button (optional): This button advances the operator to the treater Main screen. This button is only available if the bin site system is being operated in conjunction with a PLC controlled seed treater.

11. Underbin Conveyor Motor Status Indicator: Informs the operator if the underbin conveyor motor is “ON” or “OFF.”

12. “START SCALE FILL (MANUAL)” Button (optional):

Allows the operator to run seed in the auto mode from the pro box hopper. This button will only be available if the bin site system has a pro box hopper.

13. “CUSTOMER” Button: Pressing this button allows the operator to pre-enter the customer’s name. This name will be saved with the bin site report after each run of seed is made. When this button is pressed a keypad (right) will appear on the screen.

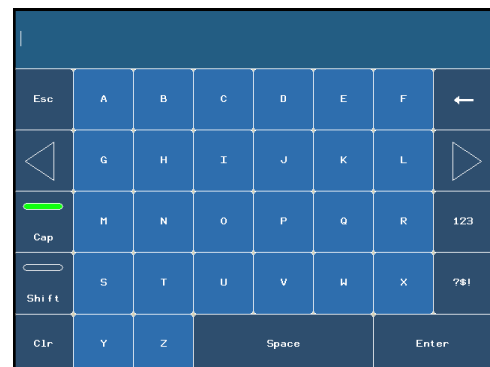

Main Screen Button Descriptions (continued)

14. Weigh Hopper Slide Gate Button & Indicator:

Pressing this button will bring up a slide gate control window (right). This allows the operator to manually open and close the slide gate that is located directly below the weigh hopper. Also, the indicator informs the operator if the weigh hopper slide gate is in the “open” or “closed” position.

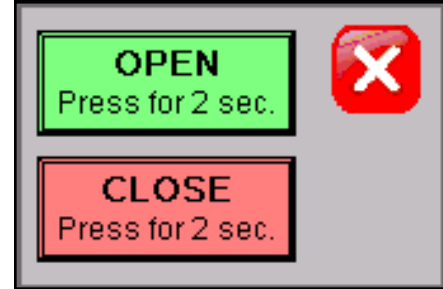

15. “START SCALE FILL (AUTO)” Button: Allows the operator to call seed into the weigh hopper from the selected bin in “auto” mode.

16. “TARGET WEIGHT” Module: Pressing this button brings up a numerical key pad (right). This allows the operator to enter the amount of seed that is to be pulled in from the selected bin. The operator can also select to call in seed via seed count units (SCU) or seed weigh units (SWU). If SCU is selected, the system will base the units upon 140,000 seeds/unit and the seed count of the currently selected bin. If SWU is selected, the system will base the units upon 50 lbs/unit.



17. “PRINT” Button: Allows the operator to print the current weight in the weigh hopper.

18. Scale Fill Conveyor Motor Status Indicator: Informs the operator if the scale fill conveyor motor is “ON” or “OFF.”

19. Bin Slide Gate Indicator: Informs the operator if the bin slide gate is in the “open” or “closed” position.

20. Bin Selection Indicator: Informs the operator of the currently selected bin.

21. “SELECT OPERATION” Button: Pressing this button will bring up a drop down list of possible system operation modes for the operator to choose from (right).

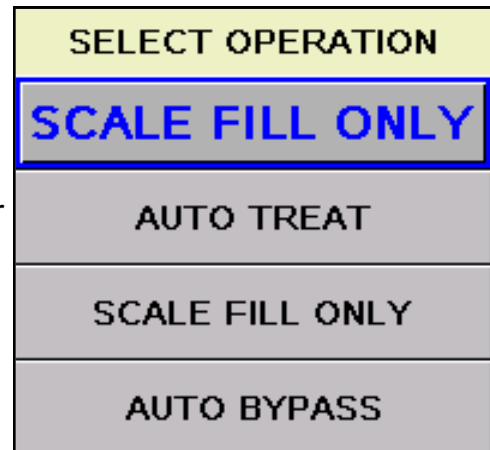

“H-O-A” (HAND-OFF-AUTO) SCREEN

Hand-Off-Auto controls are provided for most of the automated devices in the system, and are accessed on this screen.



These H-O-A buttons force the selected component to be energized (HAND), de-energized (OFF), or automatically energized by the normal logic sequence (AUTO). The HAND function will cause the component to operate independent of whatever else the system is trying to do automatically. These functions should not normally be used if the automated sequencing is active. **Be sure to understand the impact of energizing or de-energizing a component with the HAND/OFF settings before using them. These commands are not a substitute for lockout/tagout procedures when working on or near this machine. Use proper lockout/tagout procedures to disable the equipment before servicing it.**

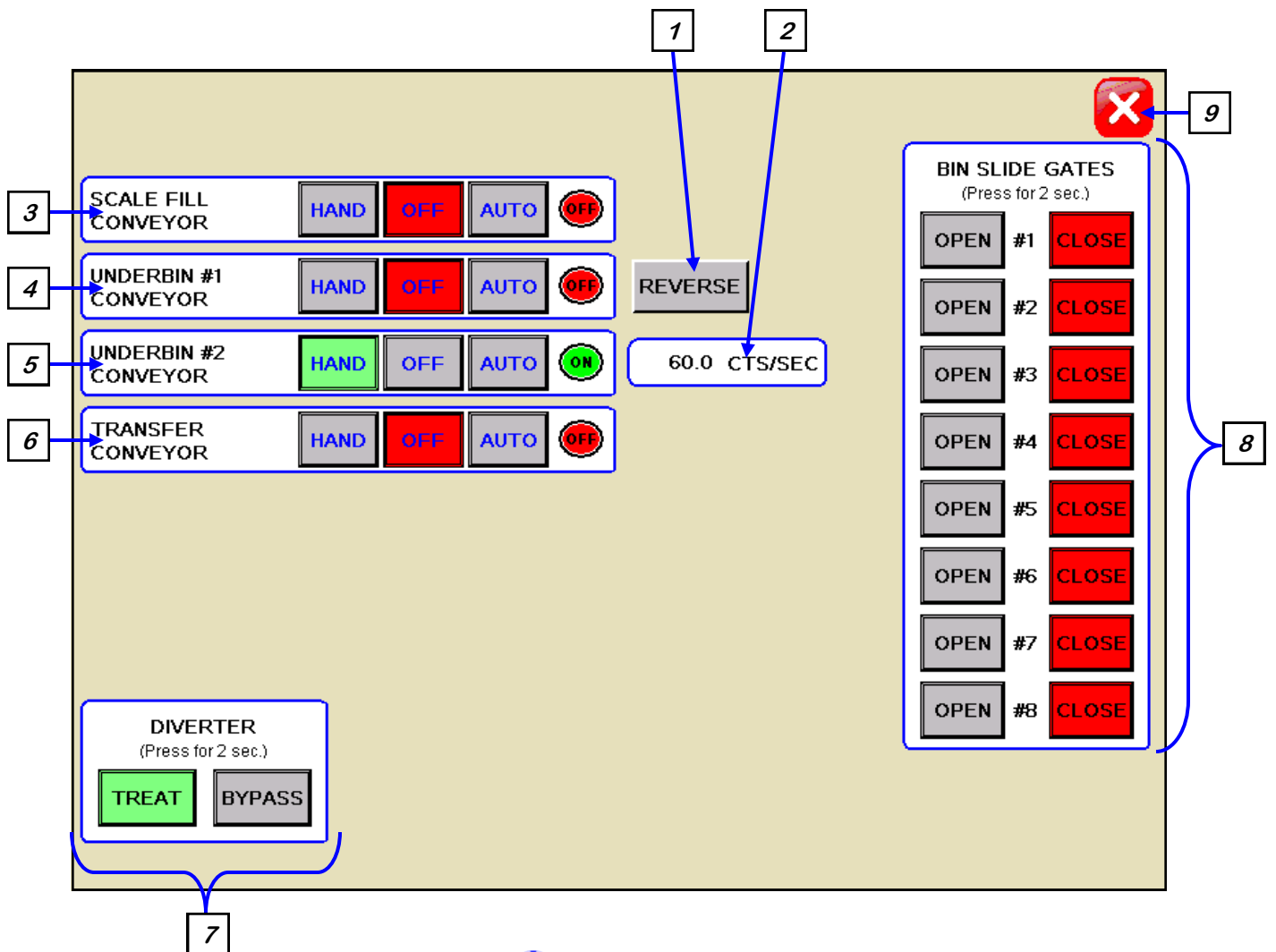

H-O-A Button Descriptions

1. “REVERSE” Button (optional): This button is only present when the underbin conveyor is in the “OFF” mode. Pressing it allows the operator to run the underbin conveyor in reverse. Once this button is pressed, the operator will also need to place the underbin conveyor to the “HAND” mode for the motor to run. **ALWAYS ENSURE THE BELT IS IMMEDIATELY AND PROPERLY ALIGNED WHEN RUNNING IN REVERSE! BELTS WILL OFTEN SHIFT ALIGNMENT WHEN THEIR DIRECTION OF TRAVEL IS REVERSED.** This button will only be present if the bin site system has the reversing option for the underbin conveyor.

2. Counts per Second Display (optional): This display shows the current counts per second that the underbin counter is reading. This allows the bin site system to be sure that the underbin conveyor is running properly and that the belt is not slipping. This display will only be present if the bin site system has an underbin counter on the underbin conveyor.

3. “SCALE FILL CONVEYOR” Control Module: This module controls the function of the scale fill conveyor. The “HAND” button will place the scale fill conveyor in the manual mode of operation. The “OFF” button will turn the associated device in the “OFF” mode of operation. The “AUTO” button will place the device in the automatic mode of operation. The motor will not operate in this function unless all other devices are in the “AUTO” mode and the “START SCALE FILL” button is pressed on the Main screen.

4. “UNDERBIN #1 CONVEYOR” Control Module: This module controls the function of the underbin #1 conveyor. The “HAND” button will place the underbin #1 conveyor in the manual mode of operation. The “OFF” button will turn the associated device in the “OFF” mode of operation. The “AUTO” button will place the device in the automatic mode of operation. The motor will not operate in this function unless all other devices are in the “AUTO” mode and the “START SCALE FILL” button is pressed on the Main screen.

5. “UNDERBIN #2 CONVEYOR” Control Module (optional): This module controls the function of the underbin #2 conveyor. The “HAND” button will place the underbin #2 conveyor in the manual mode of operation. The “OFF” button will turn the associated device in the “OFF” mode of operation. The “AUTO” button will place the device in the automatic mode of operation. The motor will not operate in this function unless all other devices are in the “AUTO” mode and the “START SCALE FILL” button is pressed on the Main screen. This button will only be present if the bin site system has a second underbin conveyor.

H-O-A Button Descriptions (continued)

6. “TRANSFER CONVEYOR” Control Module (optional): This module controls the function of the transfer conveyor. The “HAND” button will place the transfer conveyor in the manual mode of operation. The “OFF” button will turn the associated device in the “OFF” mode of operation. The “AUTO” button will place the device in the automatic mode of operation. The motor will not operate in this function unless all other devices are in the “AUTO” mode and the “START SCALE FILL” button is pressed on the Main screen. This button will only be present if the bin site system has a transfer conveyor.

7. “DIVERTER” Control Module (optional): This module controls the function of the diverter. The module allows the operator to choose if the diverter is in the “TREAT” or “BYPASS” mode. In “TREAT” mode seed will be run through the treater and in “BYPASS” mode seed will be diverted so that it does not pass through the treater. This module will only be present if the bin site system has a diverter.

8. “BIN SLIDE GATES” Control Module: This module allows the operator to manually control the operation of the slide gates that are located underneath each bin. The bin slide gates will be opened and closed automatically when the operator presses the “START SCALE FILL” button on the main screen.

9. Screen “EXIT” Button: This button is used to exit back to the previous screen. Its functionality is the same throughout the HMI display.

UTILITIES SCREEN

This screen allows the operator to set various system parameters and gives access to the “Reports”, “Security” and “Alarms” screens.

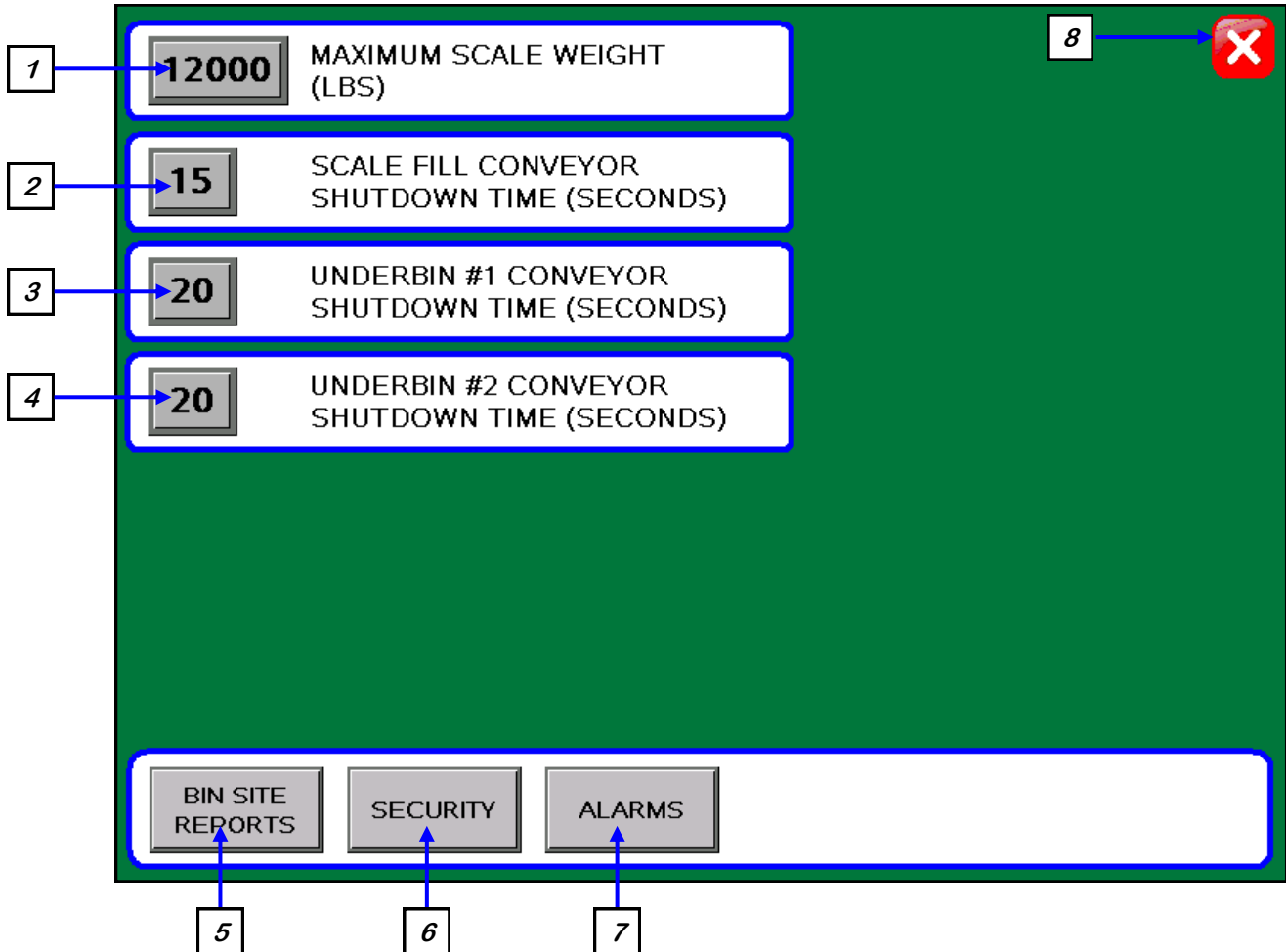

NOTICE

When buttons 1-4 are pressed, a numeric touch pad (right) will appear allowing the operator to enter a number for that particular parameter.

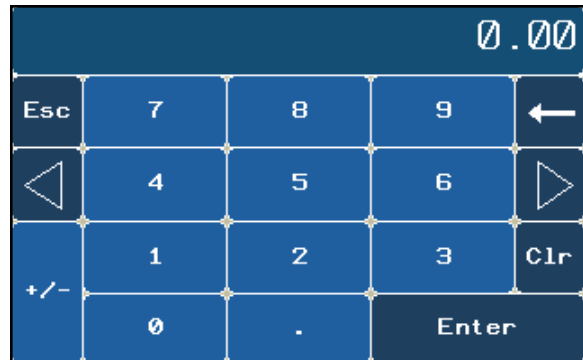

Utilities Screen Button Descriptions

1. MAXIMUM SCALE WEIGHT: Pressing this button allows the operator to adjust the maximum amount of seed that the scale can hold. If the operator calls in more seed than the maximum scale weight is set at, then the system will break up the weight and make multiple runs in order to receive the desired amount of seed.

2. SCALE FILL CONVEYOR SHUTDOWN TIME: Pressing this button allows the operator to adjust the shutdown time of the scale fill conveyor. This timer will begin once the underbin conveyor has shutdown and will allow the scale fill conveyor to clean itself out.

3. UNDERBIN #1 CONVEYOR SHUTDOWN TIME: Pressing this button allows the operator to adjust the shutdown time of the underbin #1 conveyor. This timer will begin once the bin slide gate has closed and will allow the underbin conveyor to clean itself out.

4. UNDERBIN #2 CONVEYOR SHUTDOWN TIME (optional): Pressing this button allows the operator to adjust the shutdown time of the underbin #2 conveyor. This timer will begin once the bin slide gate has closed and will allow the underbin conveyor to clean itself out. This button will only be present if the bin site system has a second underbin conveyor.

5. "BIN SITE REPORTS" Button: This button advances the operator to the Bin Site Reports screen.

6. "SECURITY" Button: This button advances the operator to the Security screen.

7. "ALARMS" Button: This button advances the operator to the Alarms screen.

8. Screen "EXIT" Button: This button is used to exit back to the previous screen. Its functionality is the same throughout the HMI display.

SECURITY SCREEN

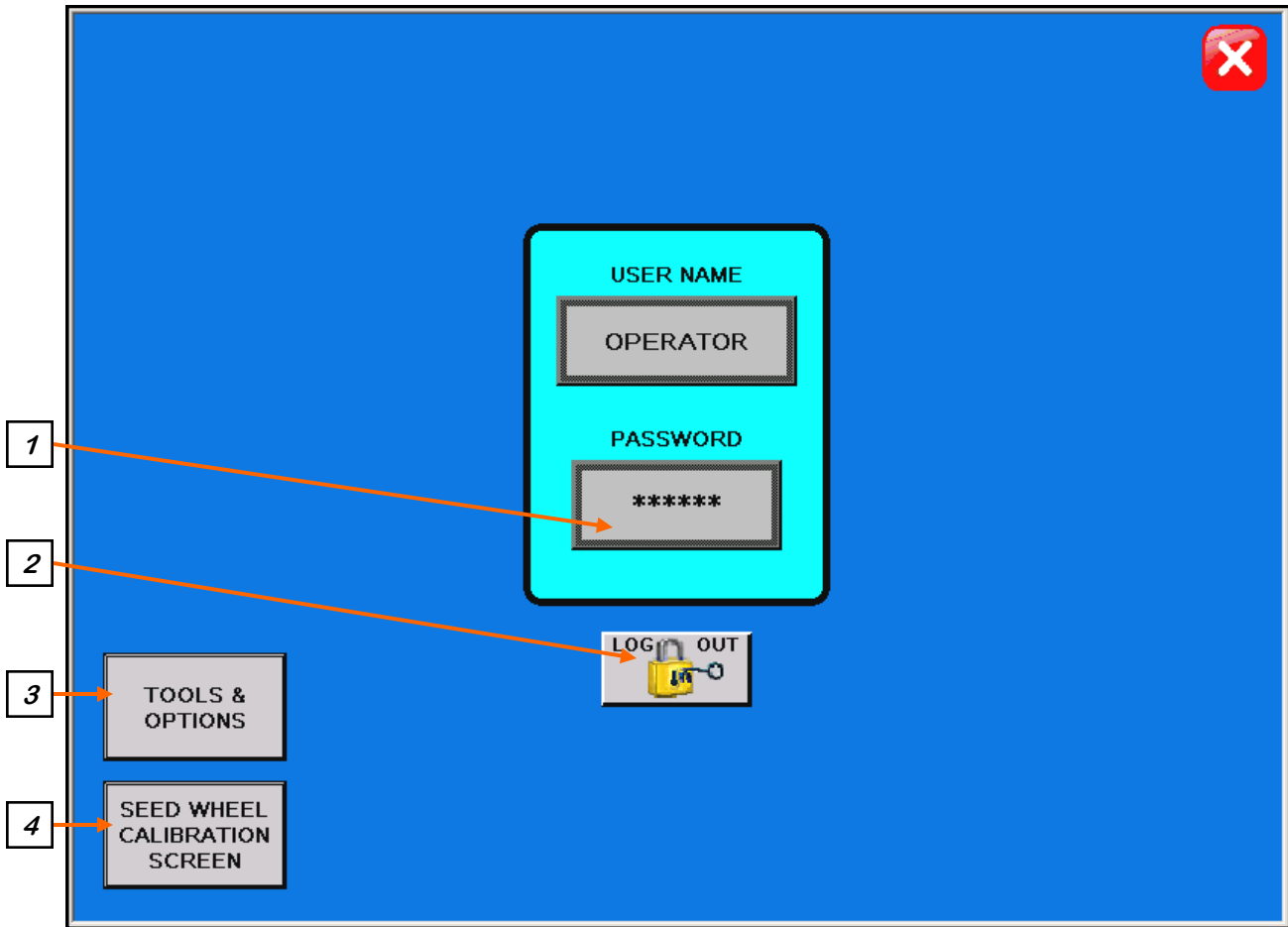

Security Screen Button Descriptions

1. "PASSWORD" Entry: The operator uses this input to obtain access to ALL options on this screen. When this button is pressed a keypad (right) will appear on the screen. The pass-code is "**USC**" and should only be made accessible to personnel qualified to operate the bin site system. The User Name will stay "OPERATOR"



Security Screen Button Descriptions

2. "LOGOUT" Button: Pressing this button will log the operator out of the Security screen. However, the operator will be automatically logged out after 1 minute of no activity on the touch screen.

3. TOOLS & OPTIONS: Pressing this button will advance the operator to the Tools & Options screen if the password has been entered.

4. SEED WHEEL CALIBRATION SCREEN (OPTIONAL): Pressing this button will advance the operator to the Seed Wheel Calibration screen (below) if the password has been entered. This option only appears if the bin site system is working in conjunction with a USC PLC based seed treater.

SEED WHEEL CALIBRATION

SEED WHEEL CALIBRATION PROCEDURE

STEP 1: "RESET" THE TOTALIZER.

STEP 2: RUN OR TREAT A KNOWN WEIGHT OF SEED.
**A MINIMUM OF 2000 LBS(900 KGS) IS RECOMMENDED

STEP 3: ENTER THE ACTUAL WEIGHT OF THE SEED INTO THE "ACTUAL SCALE WEIGHT" NUMERIC INPUT.
ENTER THE "TOTAL LBS/KGS" READING INTO THE "TOTALIZER WEIGHT" NUMERIC INPUT.

STEP 4: PRESS THE "APPLY" BUTTON TO COMPLETE THE CALIBRATION PROCESS.

ACTUAL SCALE WEIGHT: 1

APPLY

TOTALIZER WEIGHT: 1

TOTALIZER (LBS): 0

RESET

TOOLS & OPTIONS SCREEN

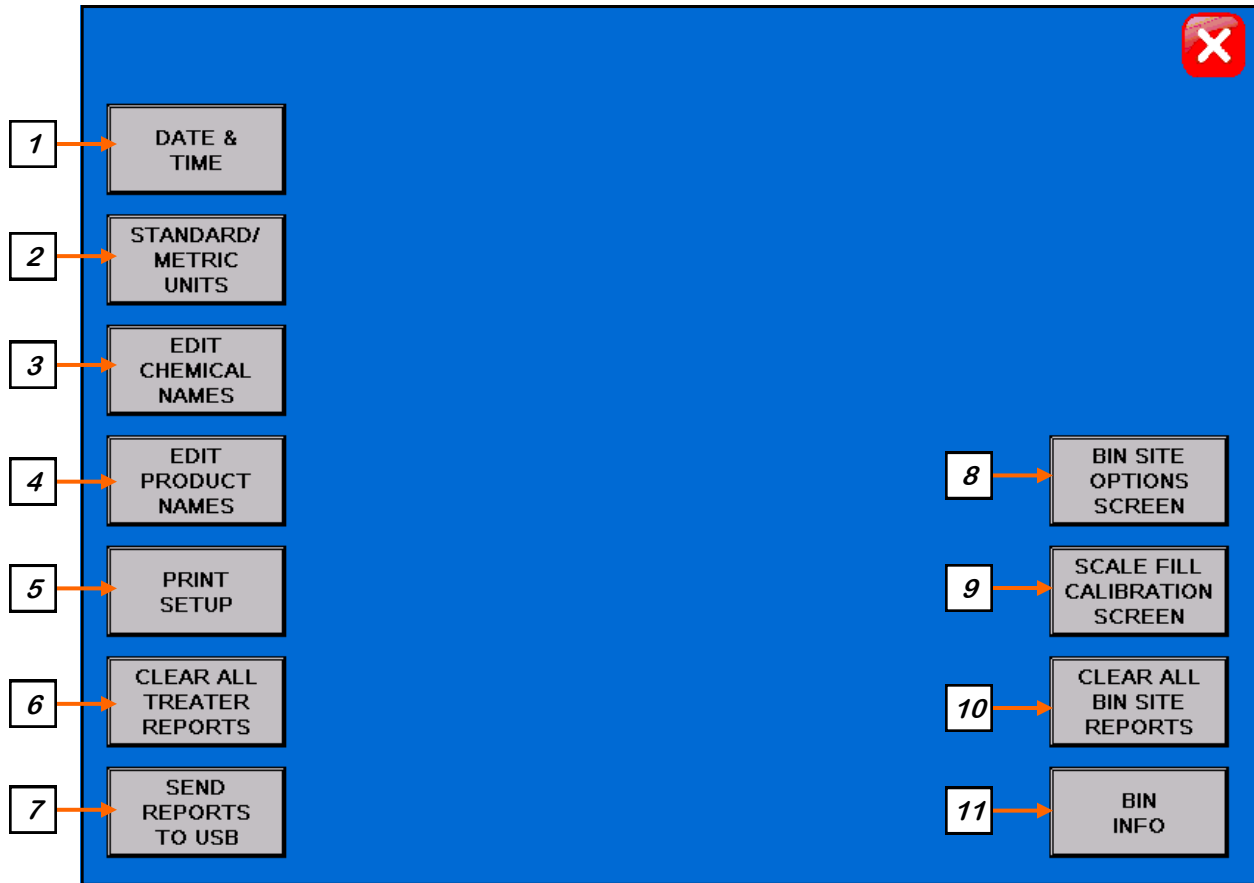

Tools & Options Screen Button Descriptions

1. DATE & TIME: This button advances the operator to a screen where the date and time can be changed. (right)

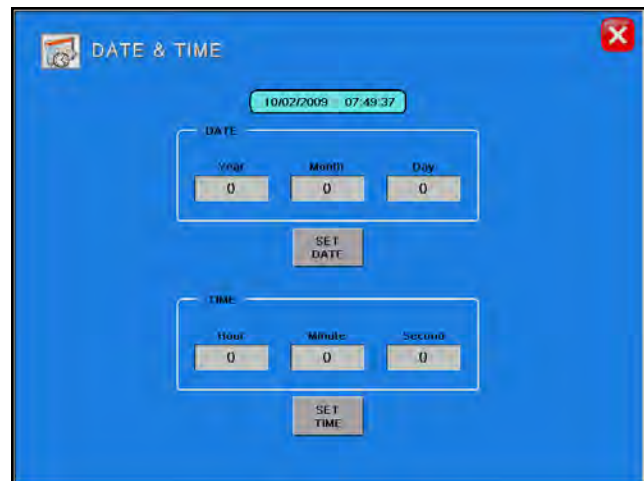

Tools & Options Button Descriptions (continued)

2. STANDARD/METRIC UNITS: Allows the operator to switch between Standard or Metric units of measurement. When this button is pressed a window will appear (below) which will allow the operator to select the desired units of measurement.

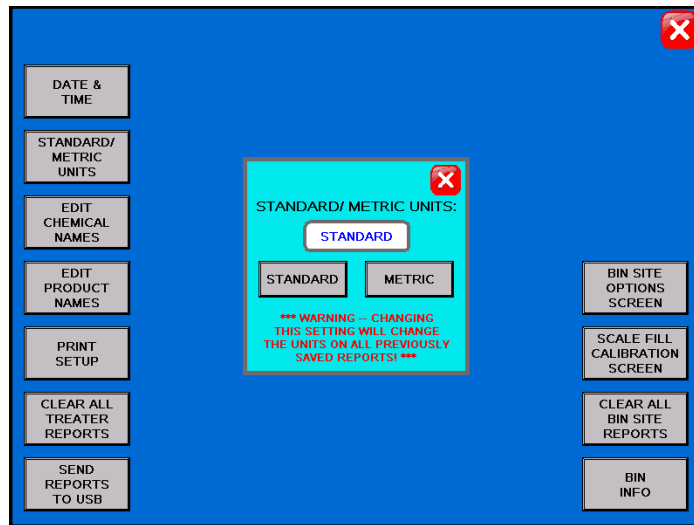

3. EDIT CHEMICAL NAMES (optional): Allows the operator to change the chemical names to better fit their needs. Pressing the button will advance the operator to the screen below. By selecting one of the chemical types, the operator can change the name of the chemical. This option only appears if the bin site system is working in conjunction with a USC PLC based seed treater.

Press this button to adjust the name of the chemical.

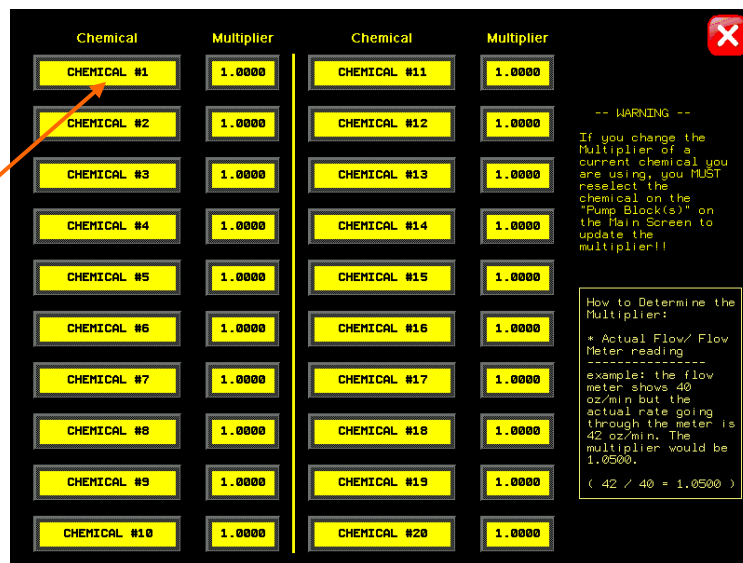

3. EDIT CHEMICAL NAMES (continued): This screen also allows the operator to recalibrate the flow meter by adjusting the multiplier for each chemical. This option only appears if the bin site system is working in conjunction with a USC PLC based seed treater.

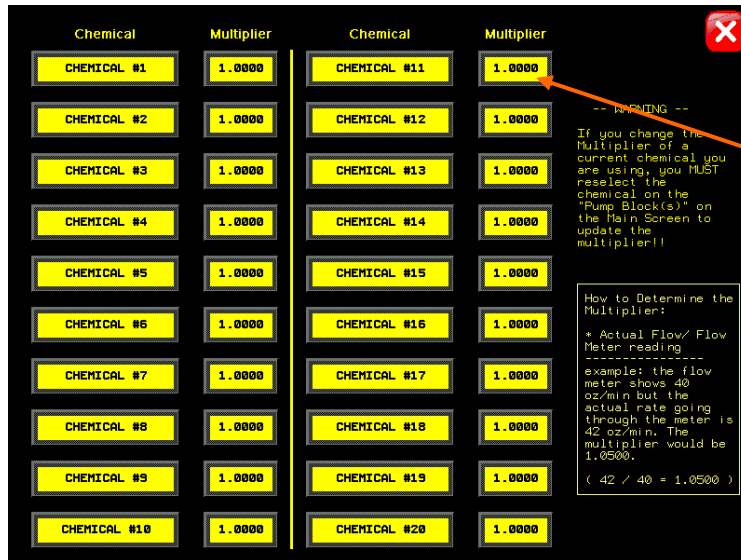

Press this button to adjust the multiplier for this chemical.

4. EDIT PRODUCT NAMES (optional): Allows the operator to change the product names to better fit their needs. Pressing the button will advance the operator to the screen below. By selecting one of the seed types, the operator can change the name of the product and the current calibration setting for the seed wheel. This option only appears if the bin site system is working in conjunction with a USC PLC based seed treater.



Tools & Options Button Descriptions (continued)

5. PRINT SETUP: Allows the operator to set up their personal company information which will be printed at the top of each report. Pressing the button will advance the operator to the screen below. The company information can be entered by selecting the blank space under each heading.

6. CLEAR ALL TREATER REPORTS (optional): Pressing this button will open a window which will ask the operator if he or she wants to clear all saved treater reports. If “YES” is pressed then the reports will be permanently erased. This option only appears if the bin site system is working in conjunction with a USC PLC based seed treater.

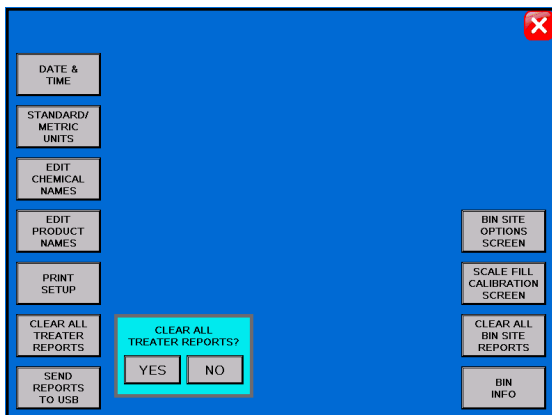

7. SEND REPORTS TO USB: If a memory stick is present in the USB port, this button can be pressed and all the saved reports will be downloaded to the memory stick.

Tools & Options Button Descriptions (continued)

8. BIN SITE OPTIONS SCREEN: Allows the operator to disable or enable the underbin conveyor counter and set the expected counts per second for this counter. This allows the system to know when the underbin conveyor belt is slipping.

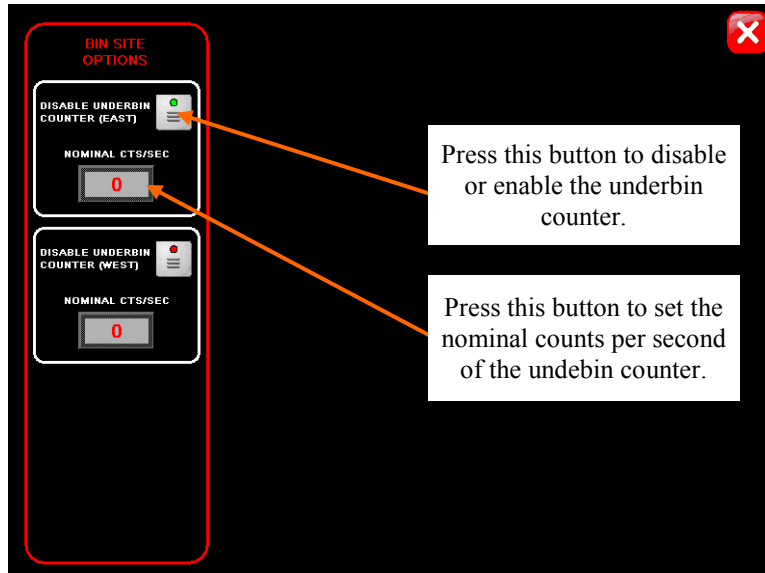

9. SCALE FILL CALIBRATION SCREEN: Pressing this button will advance the operator to the Scale Fill Calibration screen (below). This screen will allow the operator to manually calibrate the scale fill automation portion of the bin site system.

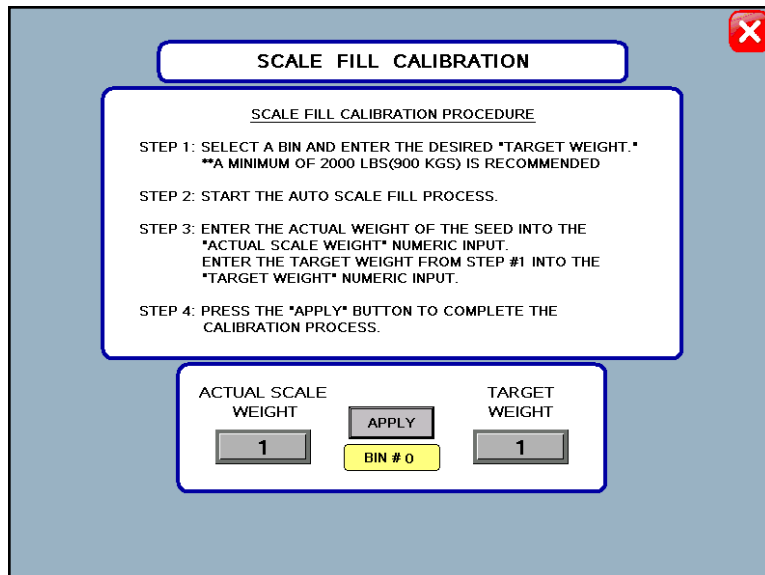

Tools & Options Button Descriptions (continued)

10. CLEAR ALL BIN SITE REPORTS: Pressing this button will open a window which will ask the operator if he or she wants to clear all the saved bin site reports. If “YES” is pressed then the reports will be permanently erased.

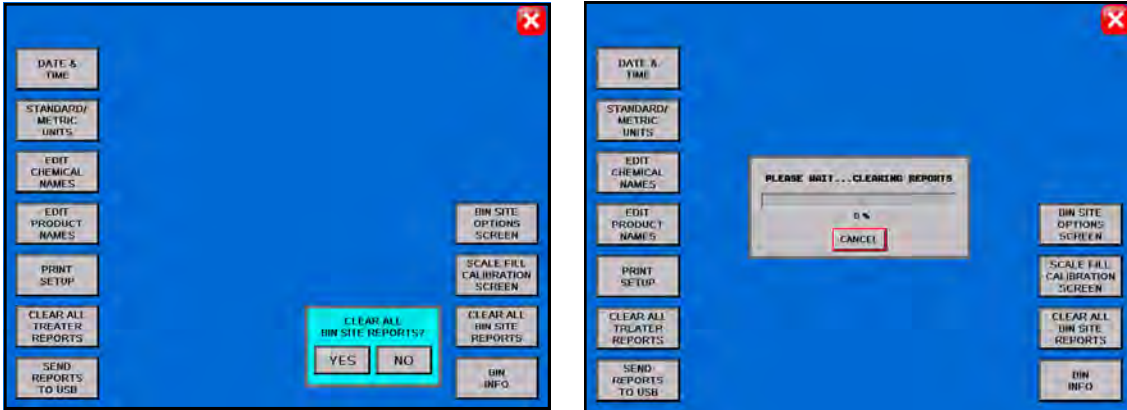

11. BIN INFO: Pressing this button will advance the operator to the Bin Info screen (below). This screen allows the operator to select the bin that the information is to be entered into.

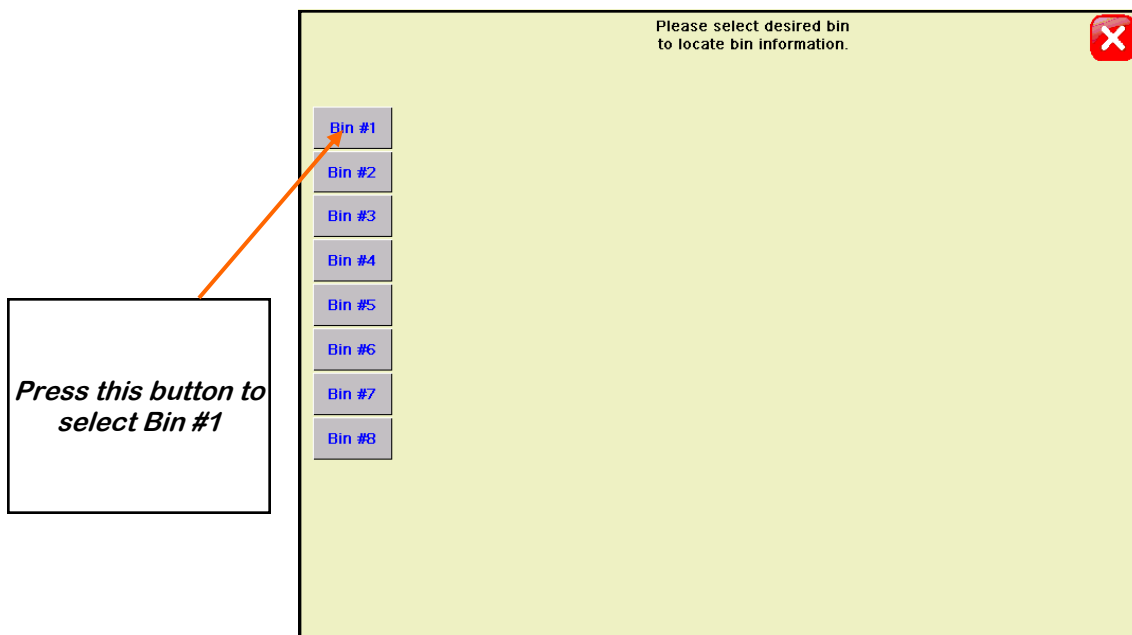

Tools & Options Button Descriptions (continued)

11. BIN INFO (continued): Once the bin is selected, several more buttons will appear on the screen (below). The operator will then be able to enter in the seed type, seed variety, lot number, seeds per pound, and cup weight of the seed in the selected bin. A keypad will appear when the button next to any of these options is pressed (right). After entering this information the “SAVE” button must be pressed for the bin site system to retain the information. The inventory of the bin may also be entered on this screen. Enter the amount of inventory that is to be added/subtracted into the “Amount to Adjust Inventory” box and then press and hold the “INCREASE INVENTORY” or the “DECREASE INVENTORY” box for 3 seconds. The total amount of inventory in the bin will be displayed in the box below the words “BIN #1 INVENTORY”.



Bin #1
X

<div style="background-color: #ccc; padding: 2px; margin-bottom: 2px;">Bin #1</div> <div style="background-color: #ccc; padding: 2px; margin-bottom: 2px;">Bin #2</div> <div style="background-color: #ccc; padding: 2px; margin-bottom: 2px;">Bin #3</div> <div style="background-color: #ccc; padding: 2px; margin-bottom: 2px;">Bin #4</div> <div style="background-color: #ccc; padding: 2px; margin-bottom: 2px;">Bin #5</div> <div style="background-color: #ccc; padding: 2px; margin-bottom: 2px;">Bin #6</div> <div style="background-color: #ccc; padding: 2px; margin-bottom: 2px;">Bin #7</div> <div style="background-color: #ccc; padding: 2px; margin-bottom: 2px;">Bin #8</div>	SEED TYPE: <input style="width: 100%;" type="text" value="SOYBEANS"/> SEED VARIETY: <input style="width: 100%;" type="text" value="ABC ABC"/> LOT NUMBER: <input style="width: 100%;" type="text" value="123 123"/> SEEDS / LB: <input style="width: 50%;" type="text" value="2500"/> CUP WEIGHT: <input style="width: 50%;" type="text" value="3.65"/> (LBS)	SAVE CANCEL	
---	---	--------------------	--

BIN #1 INVENTORY

0

(LBS)

0

Amount to Adjust Inventory (lbs)

0

DECREASE INVENTORY

Press & Hold 3 sec.

INCREASE INVENTORY

Press & Hold 3 sec.

Displays the total inventory in the selected bin.

Enter the amount of seed that is to be added here.

SECTION
E

OPERATION & CALIBRATION

LOADING SEED INTO BINS

Before seed is pulled out of the bins and run through the bin site system, information on each of the bins must first be entered into the bin site system. The following is a list of steps to perform to enter the bin information for each bin once seed has been loaded into that bin.

1. Load the seed into the bin. Take a seed sample for the cup weight of each bin at this time. Also, note the seed type, seed variety, lot number, seeds/lb, and total inventory in pounds of the seed that is loaded into the bin.
2. Press the “UTILITIES” button on the main screen of the bin site system.
3. Press the “SECURITY” button on the Utilities screen.
4. Enter the letters “U S C” into the “PASSWORD” box then press the enter button.
5. Press the “TOOLS & OPTIONS” button on the Security screen.
6. Press the “BIN INFO” button on the Tools & Options screen.
7. Select the desired bin to enter the information into. (page 35)
8. Enter the recorded seed type, seed variety, lot number, seeds/lb, and cup weight of the seed in the bin into their respective box. Press the save button when all the information has been entered. (page 36)
9. Enter in the total weight of seed that was added to the bin into the bin inventory section on the lower portion of the screen. (page 36) The system will automatically subtract inventory after each run.
10. When finished, exit back to the Main screen.

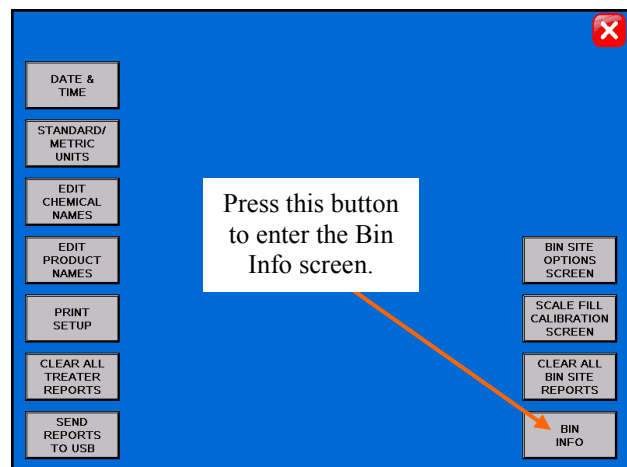
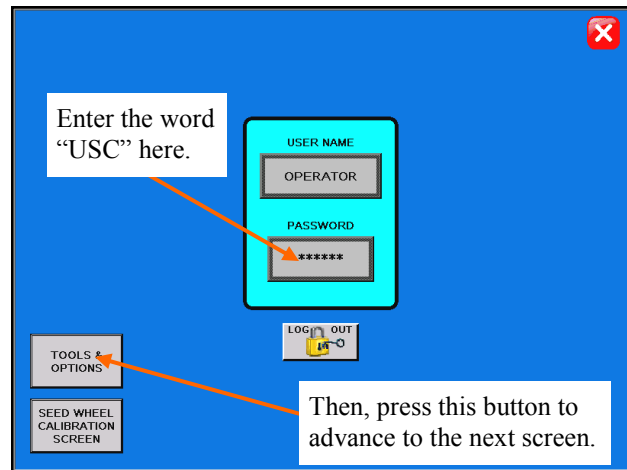

SETTING THE SEED FLOW RATE

The following is a list of steps for setting the seed flow rate. This must be completed before running the bin site system. Repeat steps 1 & 2 for each bin.

1. Set the manual gate on the bin to at least the half open position. Once opened, this gate should be set in place and not moved through out the entire season. If this gate is adjusted during a run or between runs then it will effect the calibration of the system and the system will need to be re-calibrated. (page 48)
2. Then, set the stop for the air actuated slide gate on the bin. This stop controls how far the slide gate will open and the speed at which seed can exit the bin. To set the stop, adjust the position of the collar on the rod that exits the slide gate opposite of the air valve (below). Placing the collar closer to the slide gate will restrict flow and farther away from the slide gate will increase seed flow for the system. Once a collar location has been selected, use the hitch pin to lock the collar in place. If the stop is adjusted between runs then it will effect the calibration of the system and the system will need to be re-calibrated. (page 48)

NOTICE

It is recommended to initially place the collar closer to the slide gate and then move it farther away from the slide gate one hole at a time to increase the speed of the system. This will protect against overloading the underbin conveyor with seed.

3. Finally, set the position of the manual slide gate that is located under the weigh hopper. This gate will control the flow of seed out of the weigh hopper by restricting the size of the opening from the weigh hopper. The more open the gate is, the faster seed will exit the weigh hopper. To set this gate, simply loosen the three nuts on the gate. Then adjust the gate to the desired position, and retighten the nuts.

Move the position of the collar along this rod to adjust the flow of seed through the bin slide gate.

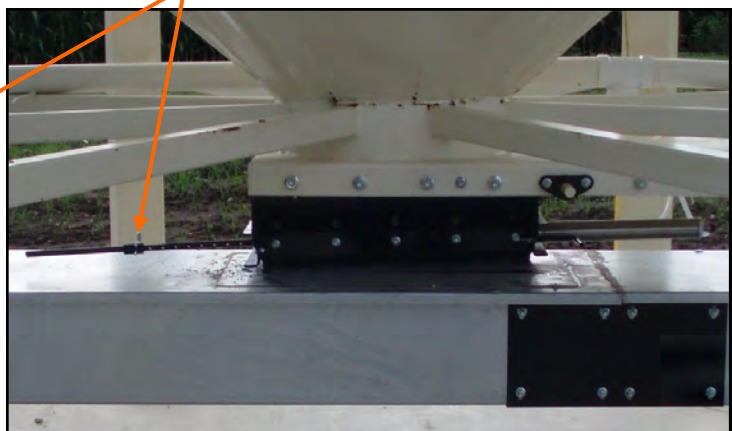
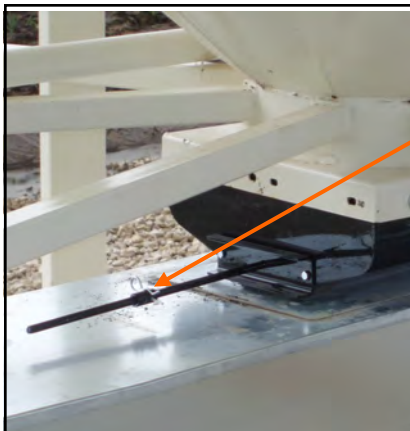

SCALE FILL ONLY

The following is a list of steps to use when running the bin site system in the “Scale Fill Only” mode of operation. This mode of operation will automatically fill the scale.

1. In the upper right corner of the Main screen select the “SCALE FILL ONLY” option from the “SELECT OPERATION” menu. (right)
2. Select the bin that you wish to call seed from by pressing the image of the corresponding bin on the Main screen. (right)
3. On the Main screen, in the box labeled “TARGET WEIGHT”, enter the amount of weight that is to be brought into the weigh hopper on this run. (right)
4. Press the box labeled “CUSTOMER” in the center of the Main screen and enter in the current customer’s name. (right)
5. Under the H-O-A screen place all necessary conveyors into the “AUTO” mode of operation. (below, left) Ensure that the diverter is in the appropriate position as well.
6. Under the Utilities screen, ensure that all settings are appropriate. USC recommends that the conveyor shutdown time is not less than 15 seconds for any given conveyor. (below, right) This will ensure that the conveyors have time to clean themselves after the run.

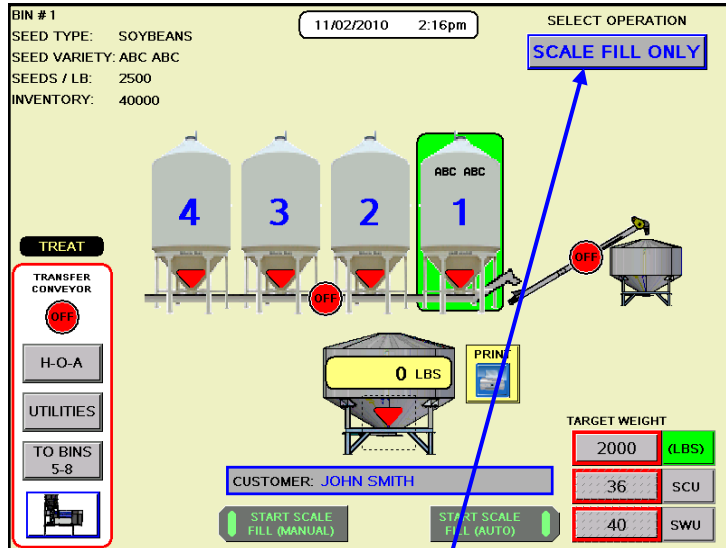

Select the “SCALE FILL ONLY” option here.

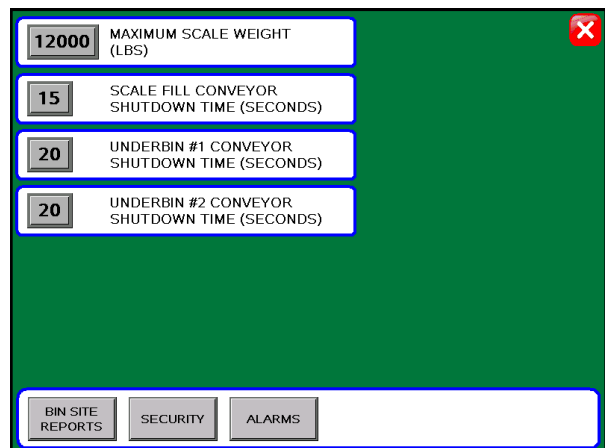
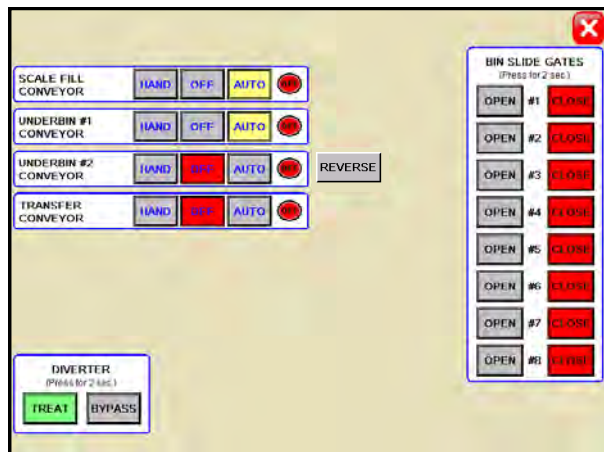

SCALE FILL ONLY (continued)

7. Advance back to the Main screen and press the “START SCALE FILL (AUTO)” button. The system will first turn on the scale fill conveyor and then the underbin conveyor. Once all needed conveyors are running, the slide gate for the selected bin will open and seed will flow through the conveyors to the scale hopper. (right, top)

8. As the bin site system is running, the Main screen will display the total pounds of seed in the weigh hopper, the current position of the bin slide gates and the status of the conveyor motors. (right, top)

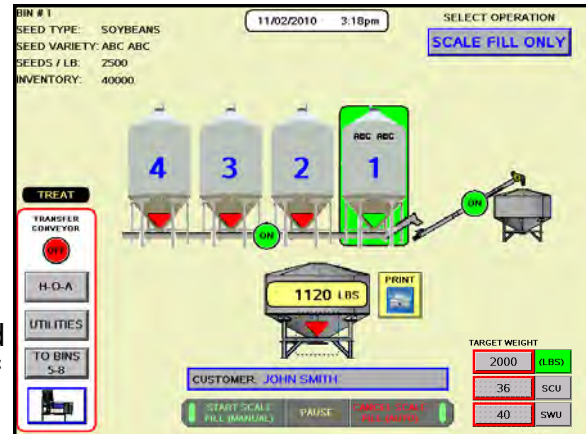

This timer displays the remaining time until shutdown.

9. The slide gate on the bin will automatically close once the target weight in seed passes through the slide gate. (right, middle) Once the gate closes, a window will appear notifying the operator that the system will shut down after a specified amount of time. The system will then shutdown the conveyors in reverse order of startup. This will ensure the conveyors have an opportunity to clean out any product from within them. Once the timer reaches zero the system will automatically calibrate itself based upon the weight of seed in the weigh hopper versus the target weight of seed for this run.

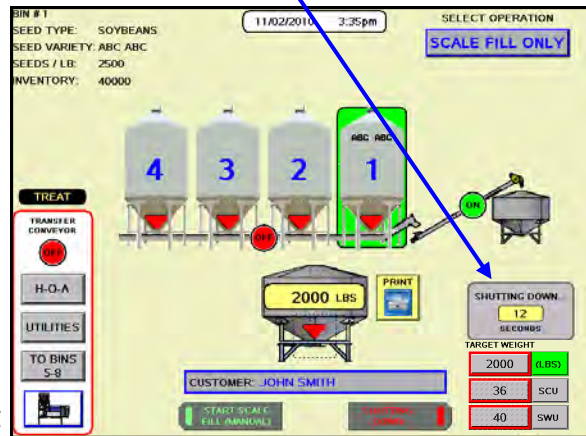

Press the “OPEN” button to empty the weigh hopper.

10. To remove the seed from the weigh hopper, the operator will need to manually open the weigh hopper slide gate and convey the seed away from the hopper. (right, bottom)

11. If the operator chose a target weight that is greater than the maximum scale weight setting, then the system will start the entire process back over until the target weight is met. Two conditions must be met before this process will re-start: the scale has to be empty and remain empty for at least five seconds and the weigh hopper slide gate must be in the “closed” position.

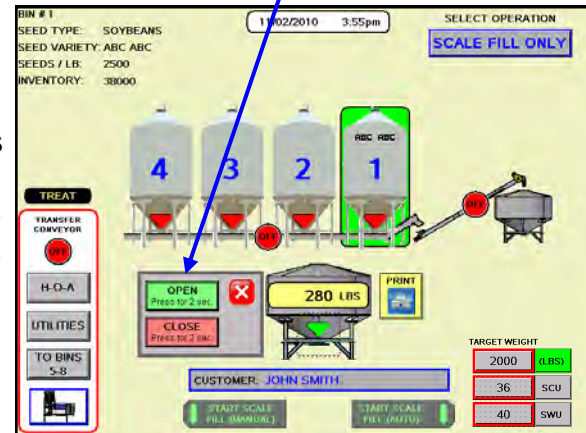

AUTO TREAT

The following is a list of steps to use when running the bin site system in the “Auto Treat” mode of operation. This mode of operation will automatically fill the scale and run the seed through the treater. “Auto Treat” mode is only available if the bin site system is being run in conjunction with a PLC based USC treater.

1. In the upper right corner of the Main screen select the “AUTO TREAT” option from the “SELECT OPERATION” menu. (right)
2. Select the bin that you wish to call seed from by pressing the image of the corresponding bin on the Main screen. (right)
3. On the Main screen, in the box labeled “TARGET WEIGHT”, enter the amount of weight that is to be brought into the weigh hopper on this run. (right)

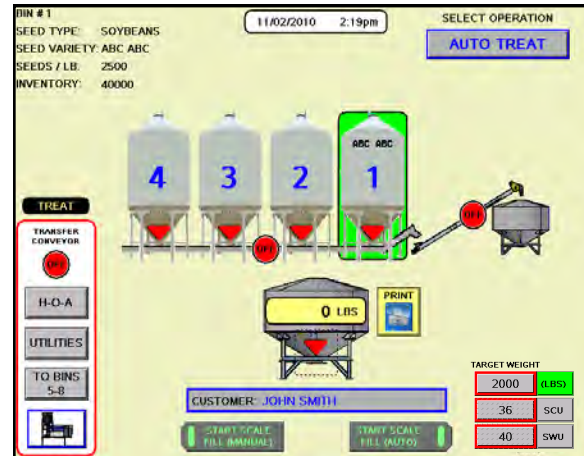

4. Press the box labeled “CUSTOMER” in the center of the main screen and enter in the current customer’s name. (right)
5. Under the H-O-A screen place all necessary conveyors into the “AUTO” mode of operation. Ensure that the diverter is in the “TREAT” position as well.
6. Under the Utilities screen, ensure that all settings are appropriate. It is recommended that the conveyor shutdown time is not less than 15 seconds for any given conveyor. This will ensure that the conveyors have time to clean themselves after the run.
7. Select the “Treater” button on the Main screen. Then, enter in all needed information and place all needed motors on the treater to the “AUTO” position. (below, right) The seed type and cup weight information will be automatically inputted based on the bin info for the selected bin. The operator must manually enter the chemical name and rate into the appropriate boxes. (bottom, left) For more information on this step, refer to the treater manual.

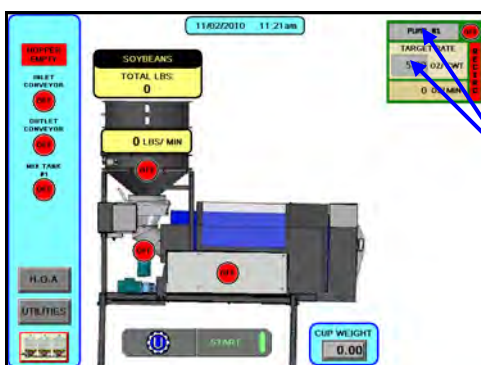

The operator must manually enter the chemical name and rate when running the system in “AUTO TREAT” mode.

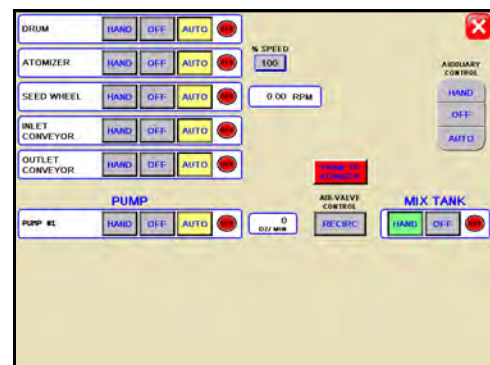

AUTO TREAT (continued)

- Advance back to the Main screen and press the “START SCALE FILL (AUTO)” button. Then press the “START” button on the pop-up window once it is verified that a truck or container is in place to catch the seed. (right, top) The system will first turn on the scale fill conveyor, then the underbin conveyor and then the underbin #2 conveyor (if applicable). Once all needed conveyors are running the slide gate for the selected bin will open and seed will flow through the conveyors to the scale hopper. (right, middle)

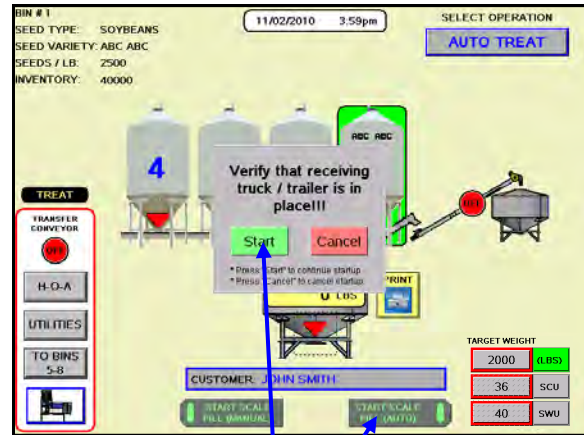

Press the “START SCALE FILL (AUTO)” and “START” button to begin the run.

- As the bin site system is running, the Main screen will display the total pounds of seed in the weigh hopper, the current position of the bin slide gates and the status of the conveyor motors. (right)

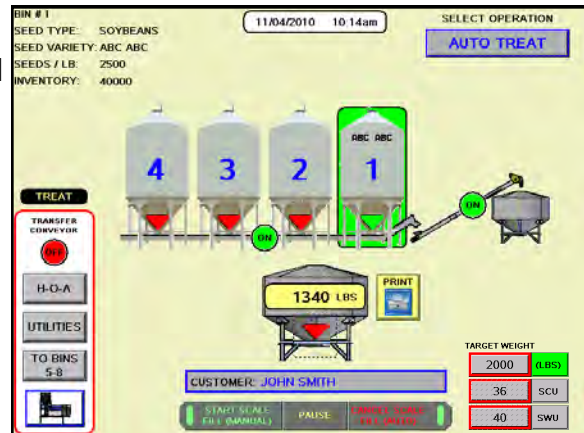

The system will automatically shutdown the bin slide gate and conveyors.

- The slide gate on the bin will automatically close once the target weight in seed passes through the slide gate. Once the gate closes, a window will appear notifying the operator that the system will shut down after a specified amount of time. The system will then shutdown the conveyors in reverse order of startup. (right, bottom) This will ensure the conveyors have an opportunity to clean out any product from within them. Once the timer reaches zero the system will automatically calibrate itself based upon the weight of seed in the weigh hopper versus the target weight of seed for this run.

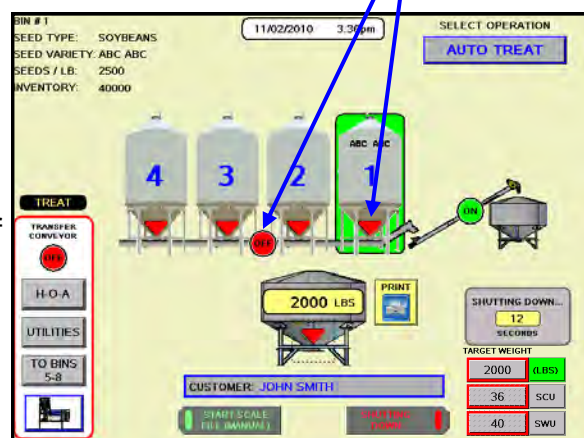

AUTO TREAT (continued)

- 11. The system will then automatically open the weigh hopper slide gate and start the treater. (below)
- 12. As seed is running through the treater, the operator can view the treater Main screen by pressing the “Treater” button on the bin site Main screen. (below)

The system will automatically open the slide gate and startup the treater.

Press this button to advance to the treater Main screen.

- 13. Once the scale has emptied and remains empty for five seconds and the seed wheel proximity sensors are no longer sensing seed, the bin site system will automatically close the weigh hopper slide gate and enter the treater into “Shutdown” mode.
- 14. If the operator chose a target weight that is greater than the maximum scale weight setting, then the system will start the entire process back over until the target weight is met.

AUTO BYPASS

The following is a list of steps to use when running the bin site system in the “Auto Bypass” mode of operation. This mode of operation will automatically fill the scale and bypass seed through the diverter. “Auto Bypass” mode is only available if the bin site system has a diverter.

1. In the upper right corner of the Main screen select the “AUTO BYPASS” option from the “SELECT OPTION” menu. (right)
2. Select the bin that you wish to call seed from by pressing the image of the corresponding bin on the Main screen. (right)
3. On the Main screen, in the box labeled “TARGET WEIGHT”, enter the amount of weight that is to be brought into the weigh hopper on this run. (right)

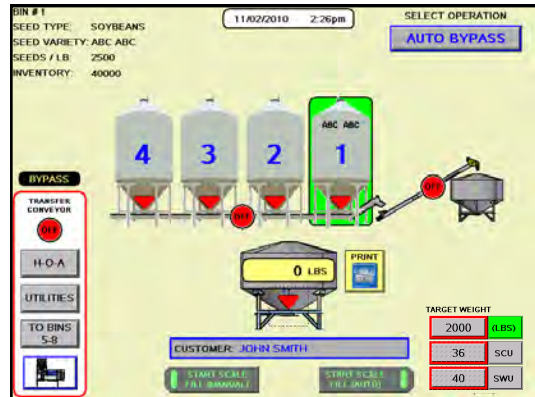

4. Press the box labeled “CUSTOMER” in the center of the main screen and enter in the current customer’s name. (right)
5. Under the H-O-A screen place all necessary conveyors into the “AUTO” mode of operation. (right) Ensure that the diverter is in the “BYPASS” position as well.
6. Under the Utilities screen, ensure that all settings are appropriate. It is recommended that the conveyor shutdown time is not less than 15 seconds for any given conveyor. This will ensure that the conveyors have time to clean themselves after the run.
7. Select the “Treater” button on the Main screen and place the inlet conveyor motor to the “AUTO” position mode. If the outlet conveyor is to be used to move seed after the seed travels through the diverter then place the outlet conveyor motor to the “AUTO” position as well. (bottom, left)
8. Under the treater Utilities screen, set the “BYPASS CONVEYOR SHUT-OFF TIME (SECONDS)” timer to an appropriate setting. (bottom, right) It is recommended that the shutdown time is not less than 15 seconds. This will ensure the conveyor has time to clean itself after the run.

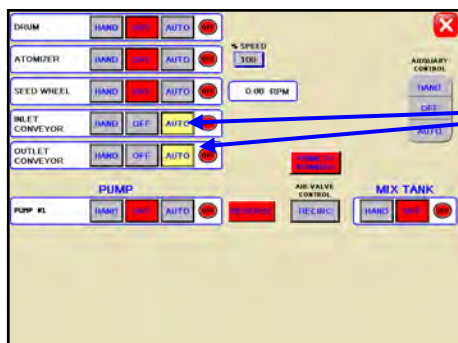

Place the conveyor motors in the “AUTO” mode.

Set the conveyor auto shutdown time here.

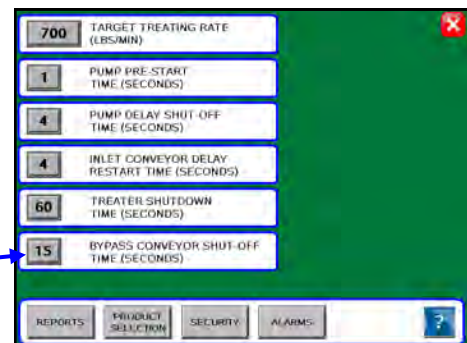

AUTO BYPASS (continued)

9. Advance back to the bin site Main screen and press the “START SCALE FILL (AUTO)” button. Then press the “START” button on the pop-up window once it is verified that a truck or container is in place to catch the seed. (right, top) The system will first turn on the scale fill conveyor, then the underbin conveyor and then the underbin #2 conveyor (if applicable). Once all needed conveyors are running the slide gate for the selected bin will open and seed will flow through the conveyors to the scale hopper.

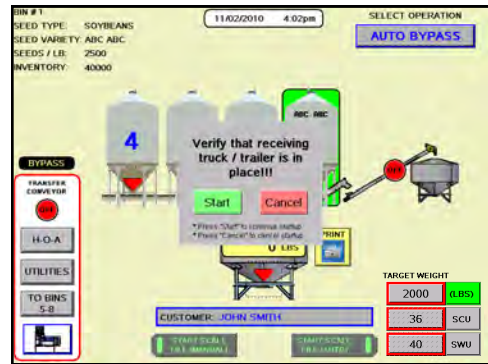

The system displays the current weight of seed in the weigh hopper.

10. As the bin site system is running, the Main screen will display the total pounds of seed in the weigh hopper, the current position of the bin slide gates and the status of the conveyor motors. (right)

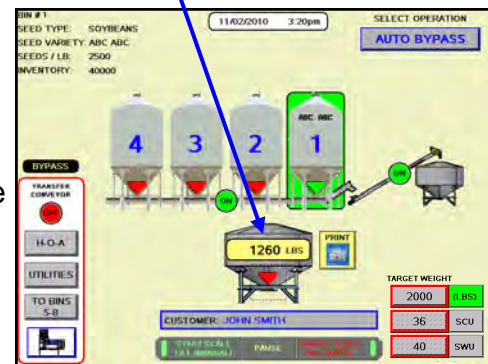

11. The slide gate on the bin will automatically close once the target weight in seed passes through the slide gate. Once the gate closes, a window will appear notifying the operator that the system will shut down after a specified amount of time. The system will then shutdown the conveyors in reverse order of startup. (right) This will ensure the conveyors have an opportunity to clean out any product from within them. Once the timer reaches zero the system will automatically calibrate itself based upon the weight of seed in the weigh hopper versus the target weight of seed for this run.

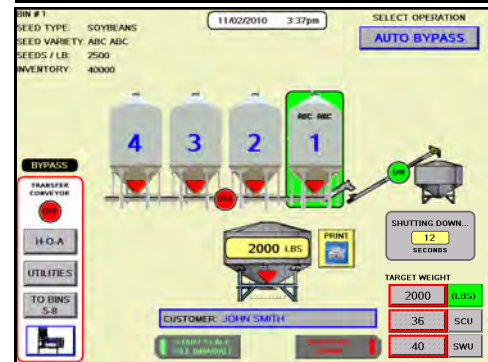

12. The system will then automatically open the scale hopper slide gate and start any conveyors that are in the “AUTO” mode. (right, bottom)

The system will automatically open the weigh hopper slide gate.

13. Once the scale has emptied and remains empty for five seconds the system will automatically close the weigh hopper slide gate and enter the conveyor(s) into the “Shutdown” mode.

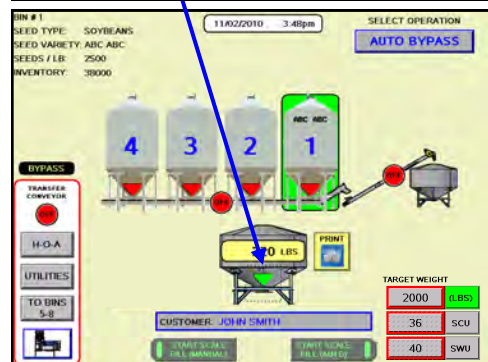

14. If the operator chose a target weight that is greater than the maximum scale weight setting, then the system will start the entire process back over till the target weight is met.

TREATING SEED FROM PRO BOXES

The following is a list of steps to use when running the bin site system using the “START SCALE FILL (MANUAL)” button. This button will automatically move seed from the pro box hopper, via the transfer conveyor, to the scale. The “START SCALE FILL (MANUAL)” button is only available if the bin site system has a pro box hopper and transfer conveyor.

1. Under the H-O-A screen place all necessary conveyors into the “AUTO” mode of operation. Depending upon the setup of the equipment, some bin sites will require only the transfer conveyor or the scale fill conveyor to be in “AUTO” mode and some sites will require the transfer, underbin and scale fill conveyors to all be in the “AUTO” mode. Ensure that the diverter is in the appropriate position as well.
2. Under the Utilities screen, ensure that all settings are appropriate. It is recommended that the conveyor shutdown time is not less than 15 seconds for any given conveyor. This will ensure the conveyors have time to clean themselves after the run.
3. Advance back to the Main screen and press the “START SCALE FILL (MANUAL)” button. (below) The system will first turn on the scale fill conveyor, then the underbin conveyor and then the transfer conveyor.
4. As the bin site system is running, the Main screen will display the total pounds of seed in the weigh hopper. If the system needs to be stopped for a moment because of a problem. The “PAUSE” button can be pressed to halt the process. When ready to begin again, the “CONTINUE” button is pressed.

5. Once all of the seed has passed from the pro box hopper, through the conveyors and into the weigh hopper, press the “STOP SCALE FILL (MANUAL)” button. At this point, the conveyors will shutdown in reverse order of startup.
6. After all of the conveyors have shutdown, press the “PRINT” button that is located next to the weigh hopper picture on the Main screen. (right) This will print the current weight of the seed in the weigh hopper.

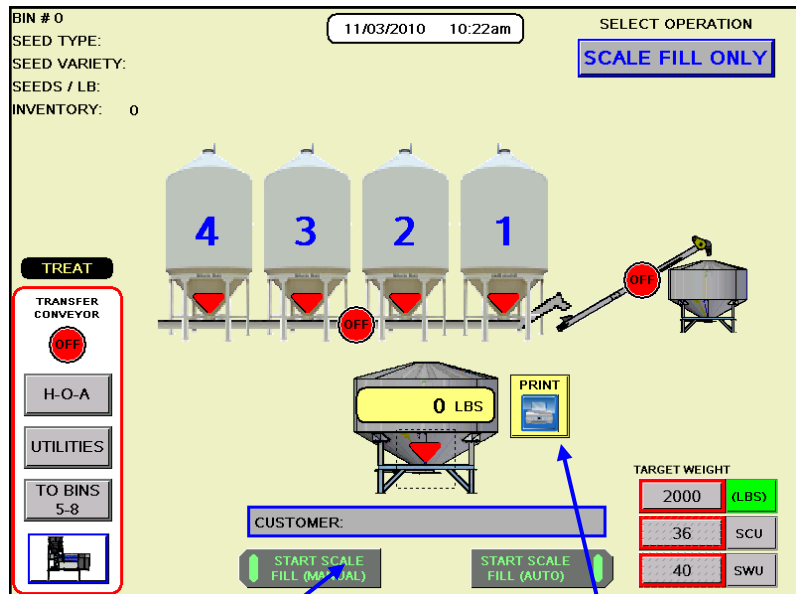

Press the “START SCALE FILL (MANUAL)” button to pull seed from the pro box hopper to the weigh hopper.

Press the “PRINT” button at any time to print the current weight in the scale.

REPORTS

The following steps explain how reports are entered after a run has been completed.

1. Once the bin site system finishes shutting down, a dialog box will appear (right), notifying the operator that the data from the run is being saved.



2. Once the data has been saved, the operator can view the report, print the report, and edit the customer name on the report by accessing the Bin Site Reports screen. To reach the Bin Site Reports screen, press the "UTILITIES" button on the Main screen and then press "BIN SITE REPORTS" button on the bottom of the Utilities screen. (right)

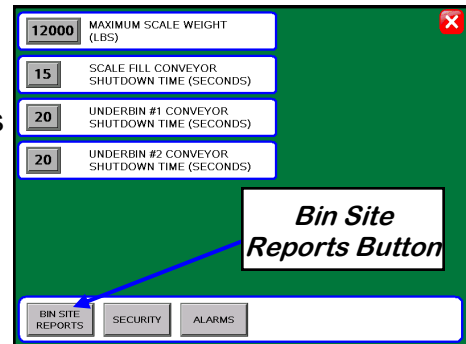

3. Under the Bin Site Reports screen, the customers information and seed information can be recorded and saved for later use. Press the "EDIT" button to change the customer name. (below) Pressing the cell next to the customer name will bring up a keypad which will allow the operator to enter in the information. When finished the operator can press the "OK" button to save the data. The "PRINT" button can be pressed to print the data for the customers records. Then press the "X" in the top right corner of the screen and exit back to the Main screen.

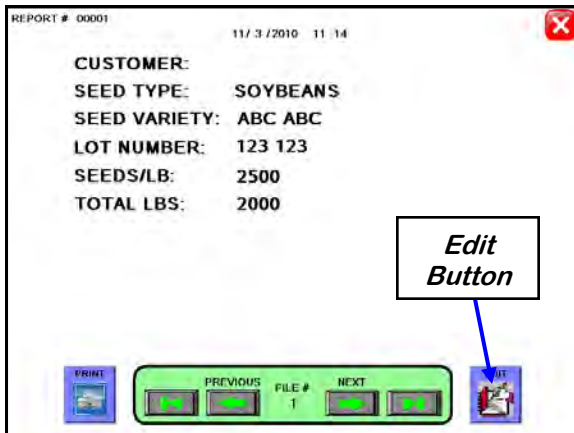

4. The operator can choose to have the system automatically print a copy of the record for each run by pressing the "SECURITY" button under the Utilities screen to advance to the Security screen. Then enter in the Password of "USC" and select the "TOOLS & OPTIONS button. (page 28) Select the "PRINT SETUP" button and finally check the "BIN SITE REPORT: AUTO PRINT" box. (right)

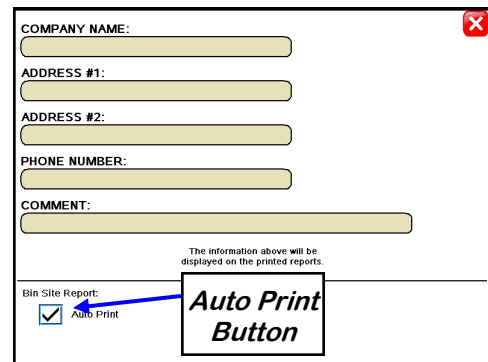

SCALE FILL CALIBRATION

Every time the bin site system runs a batch of seed in “Auto” mode, the system will perform a calibration. The calibration of the system is based upon a timing mechanism. The system compares the amount of time that the bin slide gate was in the “open” position to the weight of seed that arrived in the weigh hopper for this batch. The system will automatically subtract any weight that was previously in the weigh hopper before the batch was run. This allows the system to know how many pounds of seed per second is traveling out through the conveyors. Once this number is known, the system can then figure out how long the bin slide gate should stay in the “open” position in order to match the “Target Weight” of seed that the operator has selected. Each bin has its own specific calibration that is performed and saved after every alarm free run that is ran in the scale fill only, auto treat or auto bypass modes.

There are two ways to re-calibrate the system for a specific bin:

1. Run a small batch of seed. This will allow the system to automatically calibrate itself. The system will calibrate after every run of at least 201 pounds or kilograms for the “Target Weight” and will only remember the most recent calibration. (below, left)
2. Increase the bin inventory by 1 or more units of weight (lbs/kgs). This will reset the system back to the factory setting for this particular bin’s calibration. Then perform step #1 to achieve the correct calibration. This step should be used when the operator feels that the current calibration is incorrect by a large amount. (below, right)

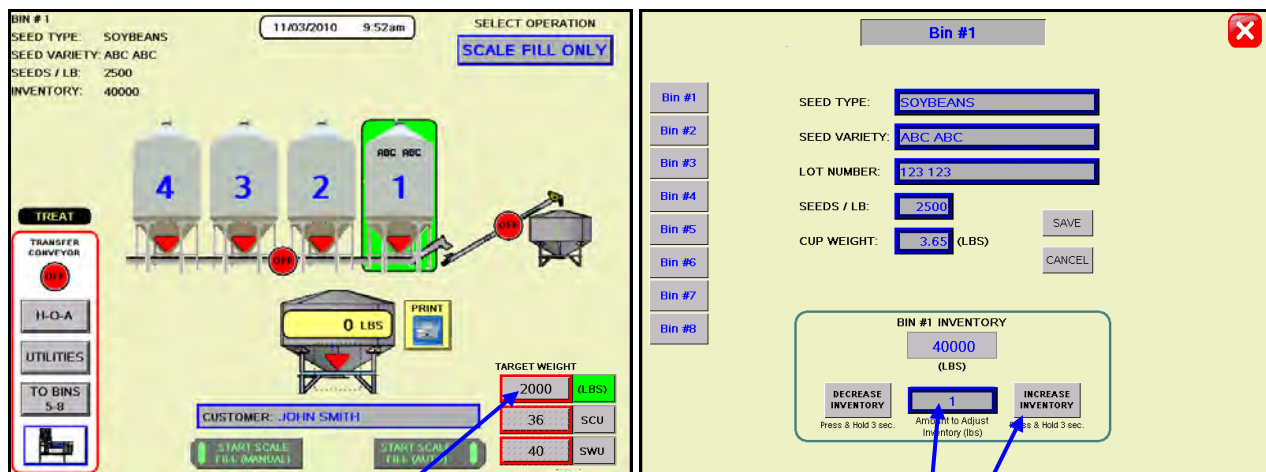

The operator must enter a “TARGET WEIGHT” of at least 201 pounds or kilograms for the system to perform an auto calibration.

Increasing the inventory by at least 1 pound or kilogram for any given bin will reset the current calibration for that bin to the factory calibration setting.

UNDERBIN OPERATION IN REVERSE MODE

The following is a list of steps to use when running the bin site system using the “Reverse” mode. This mode of operation will allow the operator to clean out the underbin conveyor and to remove any excess seed from the bins at the end of the treating season. **ALWAYS ENSURE THE BELT IS IMMEDIATELY AND PROPERLY ALIGNED WHEN RUNNING IN REVERSE! BELTS WILL OFTEN SHIFT ALIGNMENT WHEN THEIR DIRECTION OF TRAVEL IS REVERSED.** The “REVERSE” button for the underbin conveyor will only be present if the bin site system has the reversing option for the underbin conveyor.

1. Place a conveyor and seed storage container under the reversing end of the underbin conveyor to catch seed as it exits the underbin conveyor. Turn that conveyor motor on.
2. Under the H-O-A screen place the underbin conveyor into the “REVERSE” mode of operation and press the “HAND” button. (top) Ensure that the belt on the underbin conveyor is correctly aligned.
3. Then, manually place the desired bin slide gate to the “OPEN” position. (top)
4. The Main screen will show the underbin conveyor running in reverse and the selected bin slide gate in the open position. (bottom)

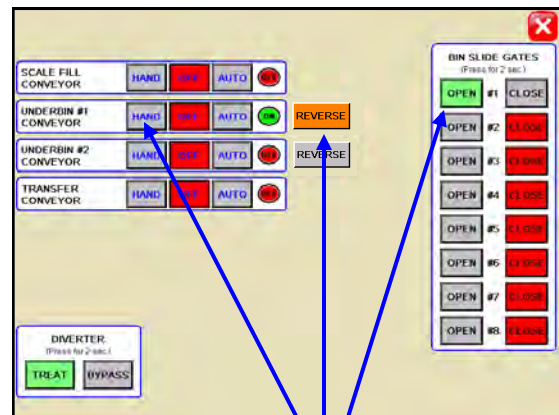

Place the underbin conveyor in “REVERSE”, press the “HAND” button and place the bin slide gate to the “OPEN” position.

5. Once all seed has passed through the underbin conveyor and into the seed container, place the open bin slide gate back to the “CLOSED” position.
6. Allow the underbin conveyor to run for at least 15 seconds. This will allow the underbin conveyor to clean itself out. Then place the underbin conveyor motor back to the “OFF” position.

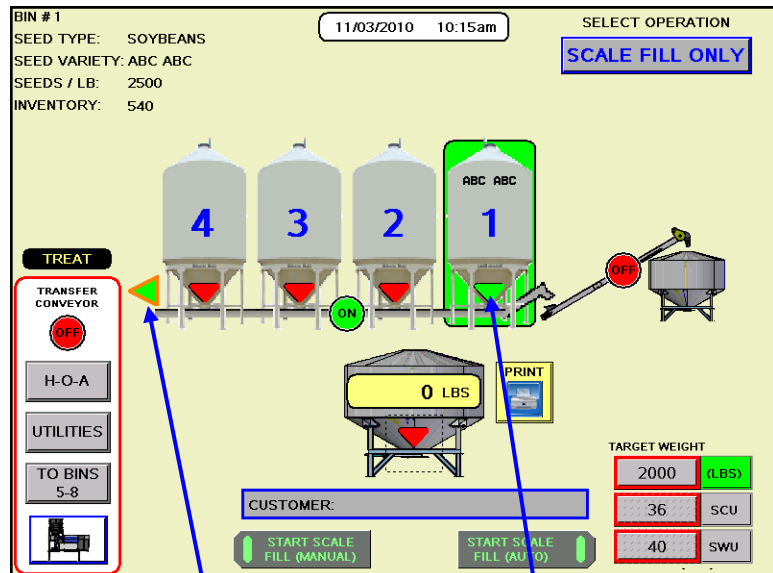

Reverse Indicator.

Slide Gate Indicator.

PRINTING & UPLOADING REPORTS

The USB port located on the side of the main control panel, allows the operator to print reports or upload reports to a Compact Flash device.

When a printer is hooked to the USB port, the operator can print a report by pressing the print button located on the Reports screen.

USB Port

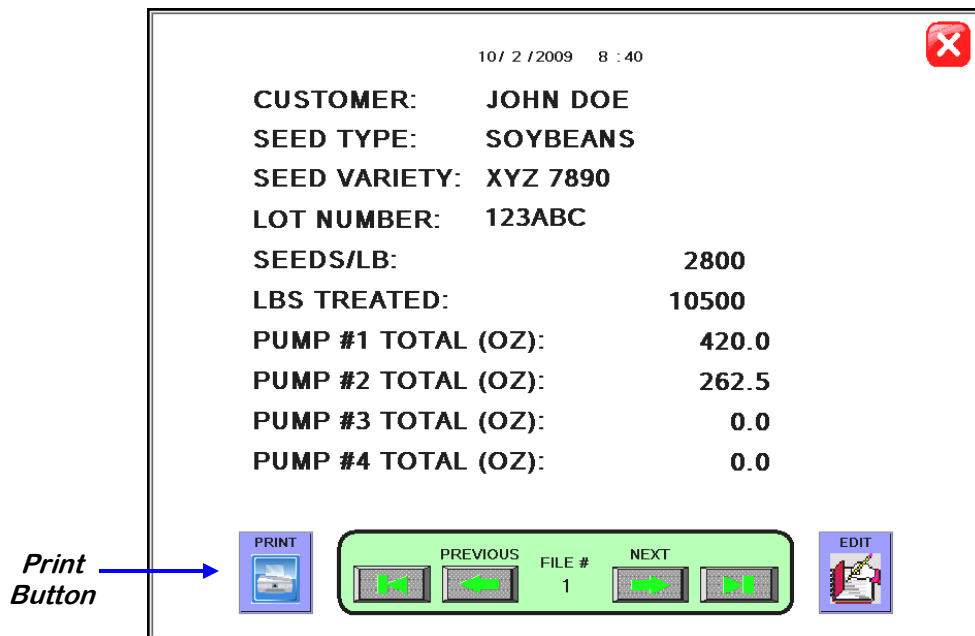
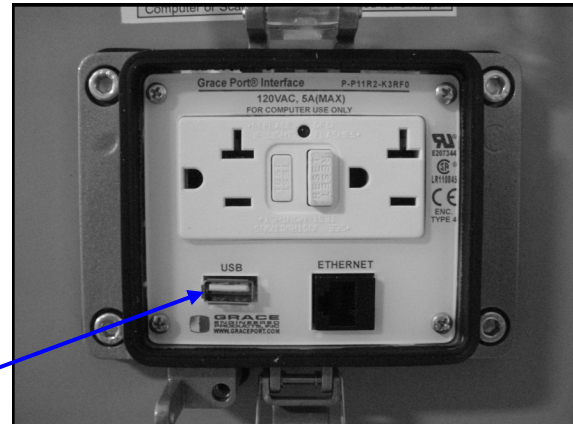

Uploading Reports

Use the following steps to upload reports to a computer.

1. Insert a Compact Flash device into the USB port.
2. Advance to the Tools & Options screen.
3. Press the “SEND REPORTS TO USB” button. A confirmation window will appear. Press the YES button and all the reports will automatically copy to the compact flash device.

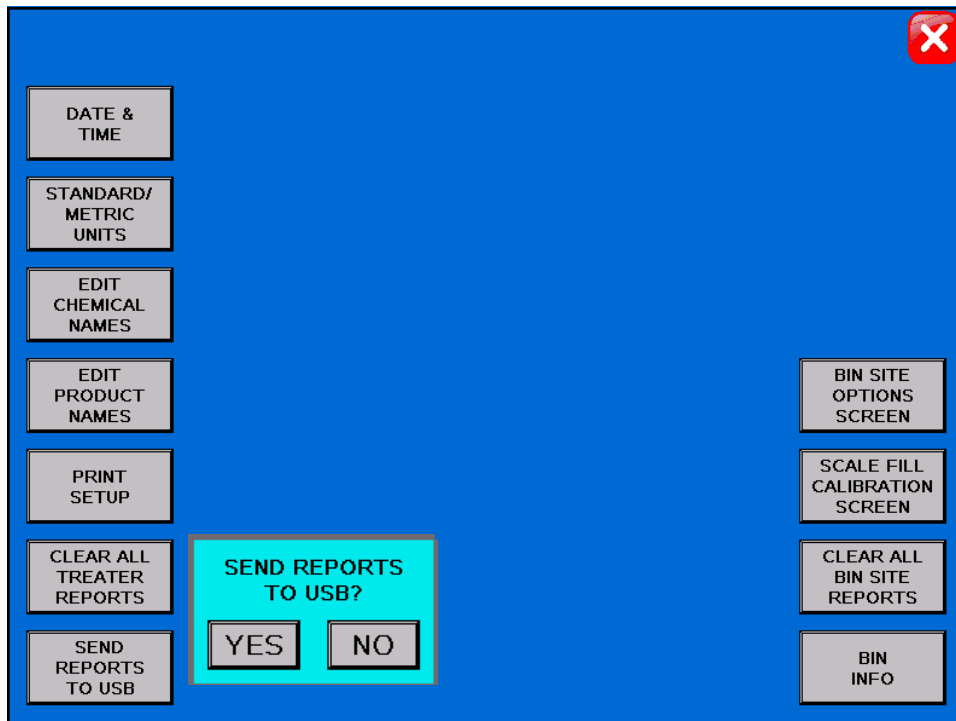

4. Remove the compact flash device from the control panel and insert into your computer. Copy the report file to your computer. The conversion will not work until the file is saved to the computer.
5. Insert the HMI Report Conversion CD into your computer and install the Report Converter Software to the computers hard drive.
6. Once the software has been downloaded, open the program Vijeo-Designer Data Manager.

7. On the main page, use the Media drop-down list to select Local Files and then click Next.



8. Select Convert Recipe or Data Logging Files and click Next.

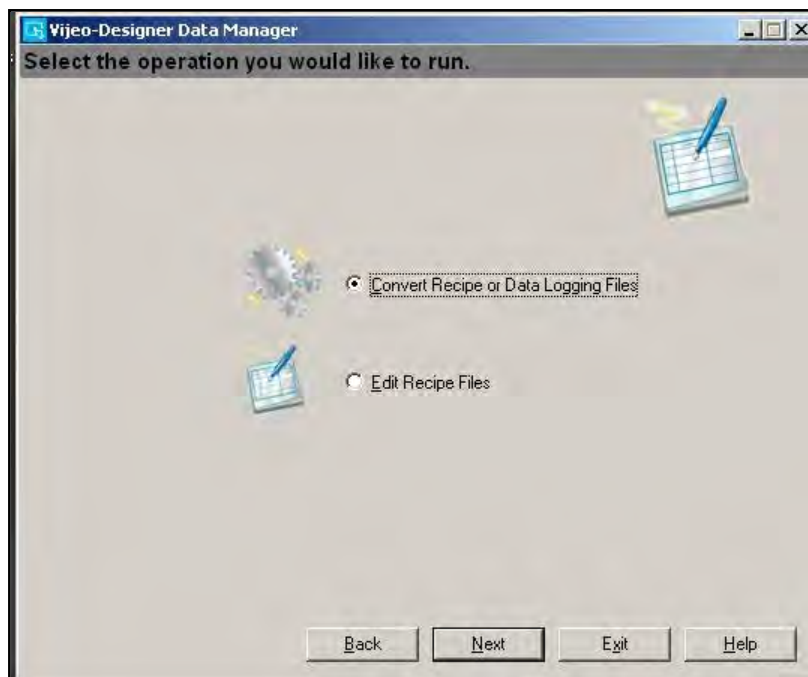

9. In the window to convert files, configure the conversion settings as required. The table below describes the conversion property settings.

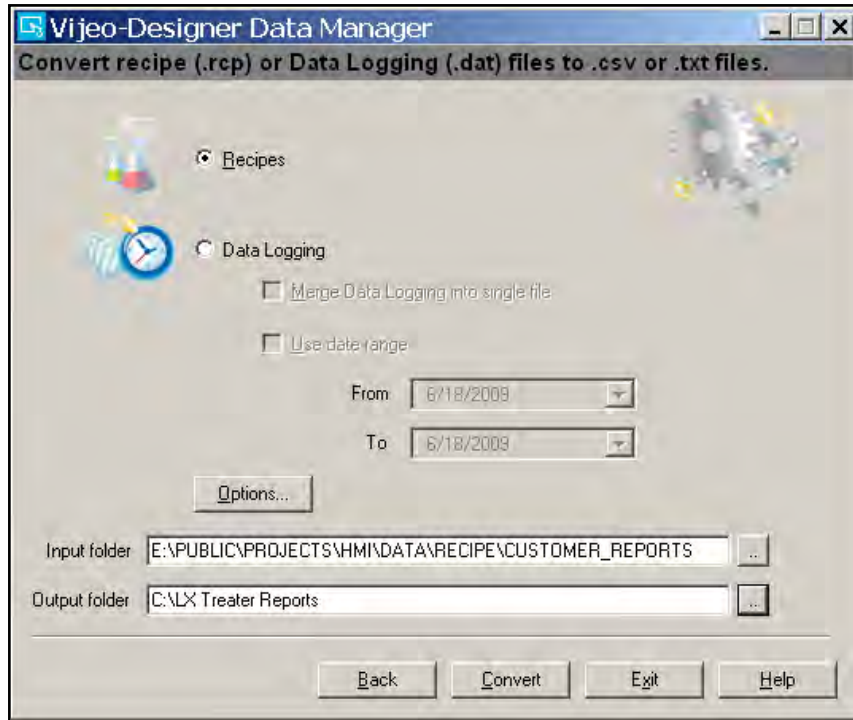

<u>PROPERTY</u>	<u>DESCRIPTION</u>
File Types	Select the file type for the Data Manager to convert Recipes (.rcp)
Input Folder	Specify the folder that contains the files to convert. Click the Input folder ellipsis button and use Windows Explorer to specify the Input folder. Alternatively, you can type the file path directly into the Input folder field. (The path above shows the folder structure that will appear on your USB drive.)
Output Folder	Specify the output folder for the converted files. Click the ellipsis button and use the Windows Explorer to select the output folder. Alternatively, you can type the file path directly into the Output Folder field.

- Click Convert to convert the files. The Data Transfer Status window appears and shows the conversion status.

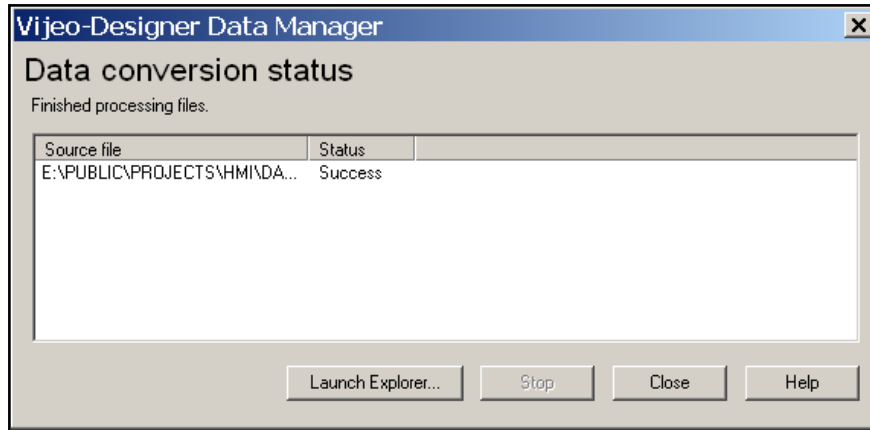

- To save converted (.csv) report files as Microsoft Excel files, start Microsoft Office Excel. In the File menu, click Open. In the Look in: drop-down list, browse to the folder you specified when converting the files. Use the Files of type: drop-down list to select "Text Files (*.prn; *.txt; *.csv)." Select the file R00001.csv and click Open.

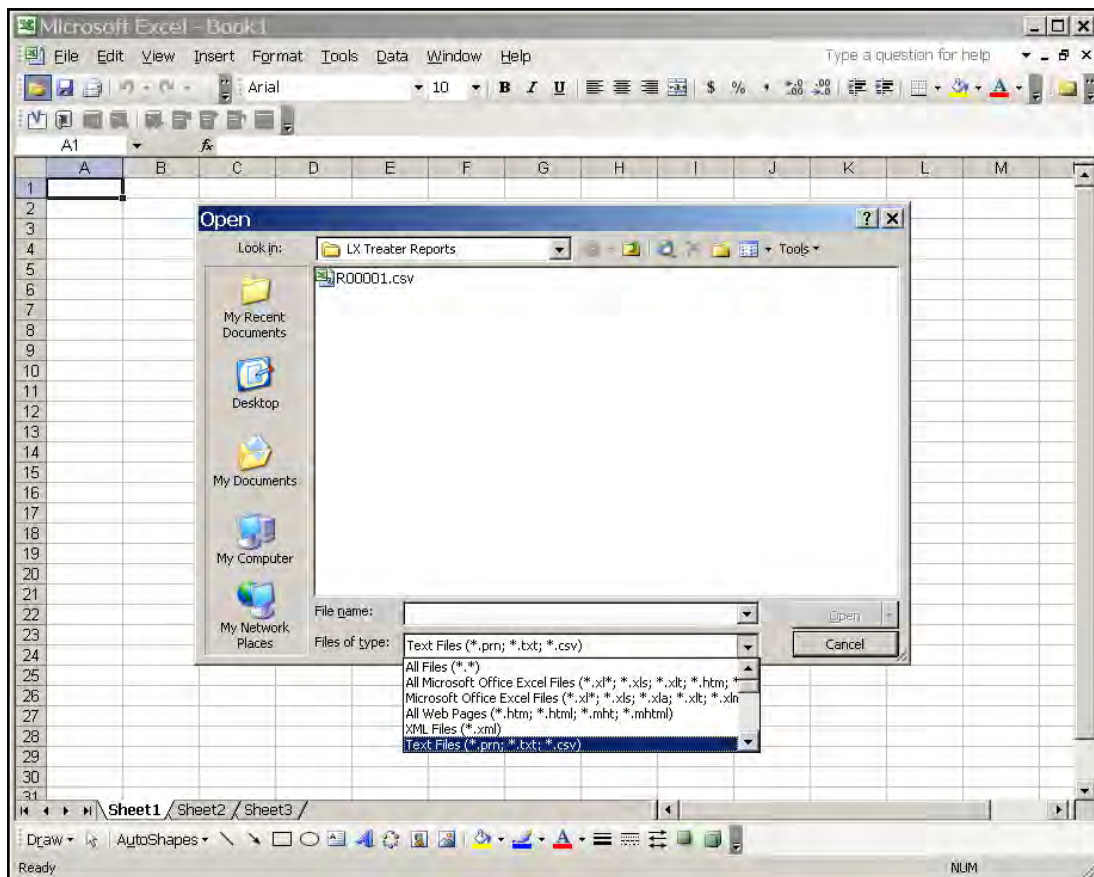

- The Text Import Wizard will open. Select Delimited as the Original data type, and enter "124" in the "Start import at row:" input. Click Next.

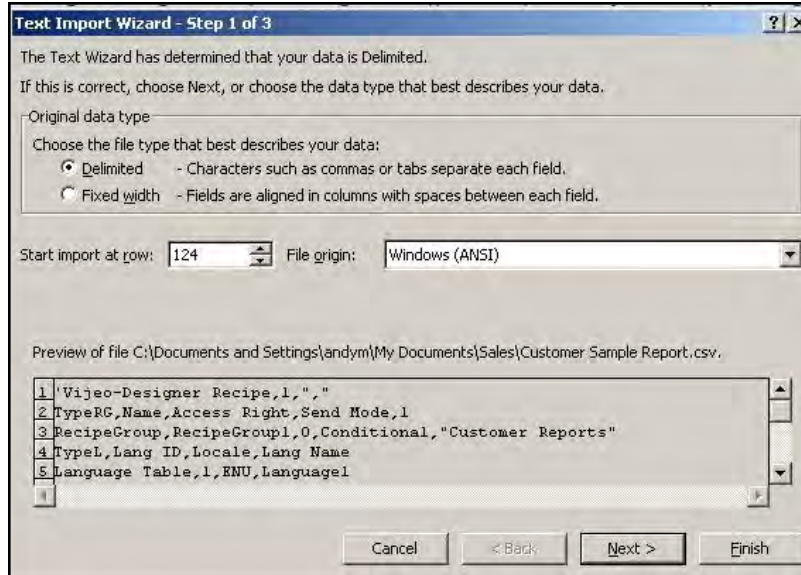

- De-select "Tab" and select "Comma" as the Delimiter. Then click Next.

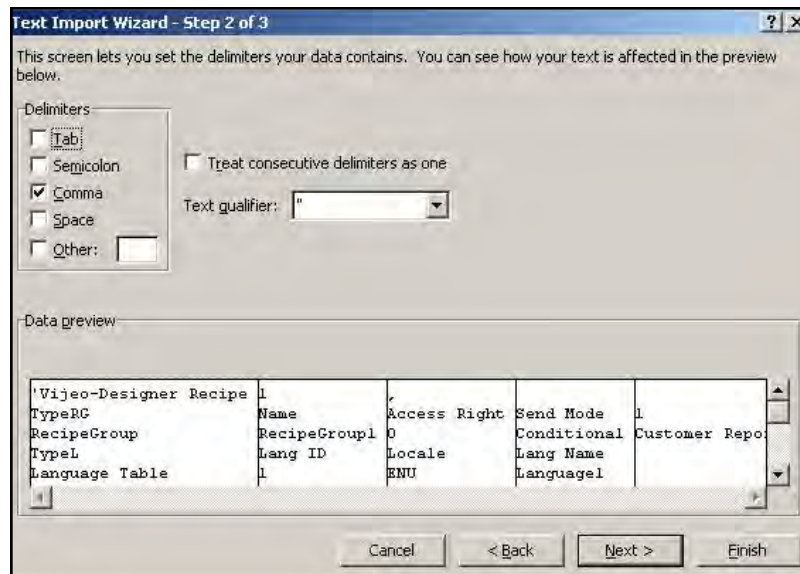

- Select "Do not import column (skip)" from the Column data format area. Then click Finish.



- The Report conversion process is complete. In the File menu, click Save As. In the Save as type: drop-down list select Microsoft Office Excel Workbook (*.xls). Click Save. The data is now in Excel format and can be modified as needed.

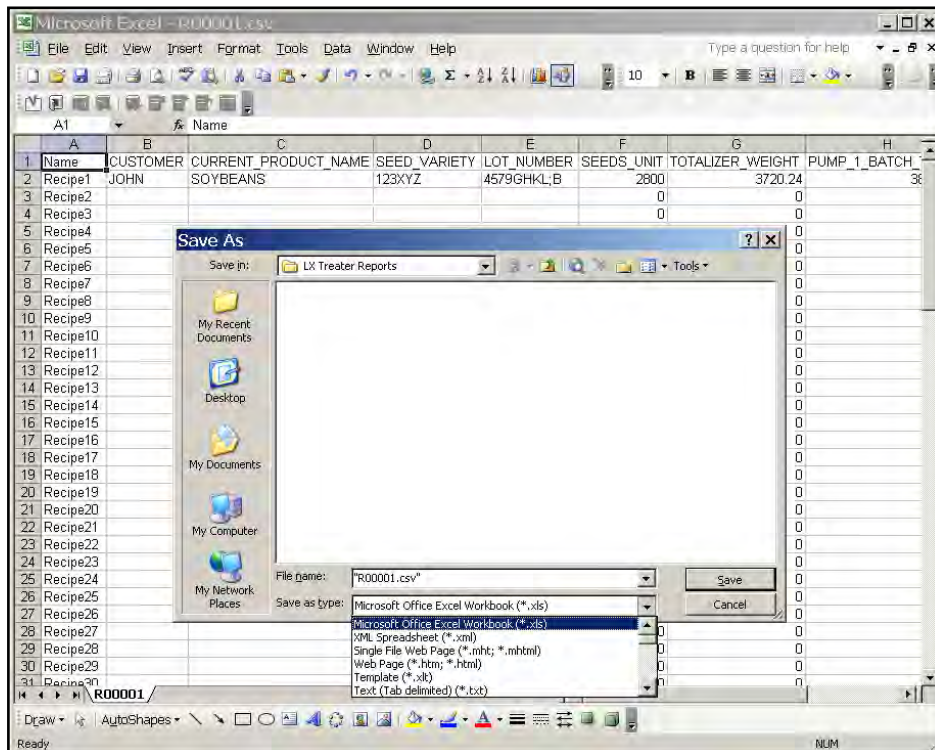

SECTION
F**TROUBLESHOOTING & ALARMS****TROUBLESHOOTING**

Below is a table describing the most frequent problems and solutions with the USC Bin Site System. For further assistance, contact your local USC dealer.

Problem	Possible Cause	Solution
System is not consistently calibrating correctly.	<ol style="list-style-type: none"> 1. Bin slides gates or manual gates have been moved. 2. Underbin conveyor belt is slipping. 3. Bin slide gate is not consistently opening to the same point. 4. The Ethernet cable is damaged or picking up electrical interference. 5. The operator is pressing the "Cancel Scale Fill" button before the run ends. 	<ol style="list-style-type: none"> 1. Ensure that the slide gate collar and manual gate is locked into place. Then recalibrate. 2. Tighten the underbin conveyor belt . 3. Check for any obstruction that may be restricting the movement of the slide gate. 4. Ensure that Ethernet cable is no located directly next to any electrical lines. 5. Allow the system to shutdown on its own.
System calibration for currently selected bin is incorrect.	<ol style="list-style-type: none"> 1. System needs recalibrated. 2. System is too far out of calibration to recalibrate automatically. 	<ol style="list-style-type: none"> 1. Run a small batch of seed to automatically recalibrate the currently selected bin. 2. Add at least 1 pound of inventory to the bin that is miscalibrated. This will reset the calibration back to the factory setting.
Solenoids are making a buzzing sound when air gates are actuated.	<ol style="list-style-type: none"> 1. Moisture in the air system. 2. Electric actuator on solenoid bank may be faulty. 	<ol style="list-style-type: none"> 1. Remove moisture from the air lines. 2. Replace the electronic actuator on the solenoid.
Conveyor will not start in "HAND" or "AUTO" mode.	<ol style="list-style-type: none"> 1. Conveyor motor starter is tripped. 2. Conveyor is clogged. 	<ol style="list-style-type: none"> 1. Reset motor starter. 2. Remove obstruction or debris.
No scale reading on the weigh hopper indicator on the touch screen.	<ol style="list-style-type: none"> 1. Ethernet cable is disconnected. 2. Scale head is unplugged. 	<ol style="list-style-type: none"> 1. Check all Ethernet cables for connectivity and damage. 2. Ensure that the scale head has power and is turned on.
Air gate will not close fully.	<ol style="list-style-type: none"> 1. Something is obstructing the air gate from closing. 2. Air pressure to the gate is not strong enough. 	<ol style="list-style-type: none"> 1. Remove obstruction. 2. Ensure that the air gate has at least 100 psi of air being supplied to it.

BIN SITE SYSTEM

Problem	Possible Cause	Solution
No air gates will open or close when their corresponding button is pressed on the touch screen.	<ol style="list-style-type: none"> 1. No air or not enough air is being supplied to the solenoid bank on the side of the control panel. 2. The bin site PLC may be off. 	<ol style="list-style-type: none"> 1. Ensure that at least 100 psi of air is being supplied to the solenoid bank. 2. Ensure that the bin site control panel has power to it, is "on" and that all of the breakers inside the panel are "on" as well.
Diverter is leaking seed through bypass side while in "treat" mode of operation.	<ol style="list-style-type: none"> 1. Too low of air pressure to actuate the diverter. 2. An obstruction in the diverter is stopping correct placement of the diverter plate. 	<ol style="list-style-type: none"> 1. Ensure that at least 100 psi of air pressure is present at the diverter. 2. Remove obstruction.
Scale is reading incorrect weight.	<ol style="list-style-type: none"> 1. Scale is binding. 2. Something is touching the scale. 3. Scale needs recalibrated. 4. Ethernet cable may be damaged or receiving electrical interference. 	<ol style="list-style-type: none"> 1. Check scale arms for any binding. 2. Ensure that the area around the scale is clean and that nothing is leaning on or resting on the scale and hopper. 3. Zero scale. If still incorrect, then have a professional scale technician recalibrate the scale. 4. Ensure that Ethernet cable is not located directly next to any electrical lines.
Inlet conveyor to treater is overfilling with seed.	<ol style="list-style-type: none"> 1. The proximity sensor at the top of the inlet hopper is not properly located so that seed is contacting it when the inlet hopper is full. 2. There is obstruction to the seed flow at the discharge end of the inlet conveyor. 	<ol style="list-style-type: none"> 1. Move the proximity sensor so that it is in a location for seed to come in contact with it once the inlet hopper is full. 2. Remove the obstruction.
Air gate is opening when it should be closing and vice versa.	<ol style="list-style-type: none"> 1. Air lines to the air gate are reversed. 	<ol style="list-style-type: none"> 1. Exchange air line for the proper solenoid on the back of the solenoid bank.
The touch screen has warning triangles on each button.	<ol style="list-style-type: none"> 1. The bin site PLC may be off. 2. The Ethernet cable between the treater control panel and the bin site control panel may be unhooked or damaged. 	<ol style="list-style-type: none"> 1. Ensure that the bin site control panel has power to it, is "on" and that all of the breakers inside the panel are "on" as well. 2. Check the Ethernet cable for damage and ensure that it is plugged in correctly.

SYSTEM ALARMS - FAULTS

The table below and on the following pages provides a general description of all the system alarms (faults & warnings) of the Bin Site System. When a fault or warning condition is detected by the system, the Alarms screen will pop-up describing the cause of the Alarm or Fault. Any motor fault will activate the alarm screen on the operator control panel. If running, the system will then progress to the controlled shutdown state. A warning will alert the operator of a system condition which needs attention or correction. The alarms are reset when the fault condition is cleared. The horn is silenced by pressing the “Silence Alarm” button on the Alarms screen. For further assistance, contact your local USC dealer.

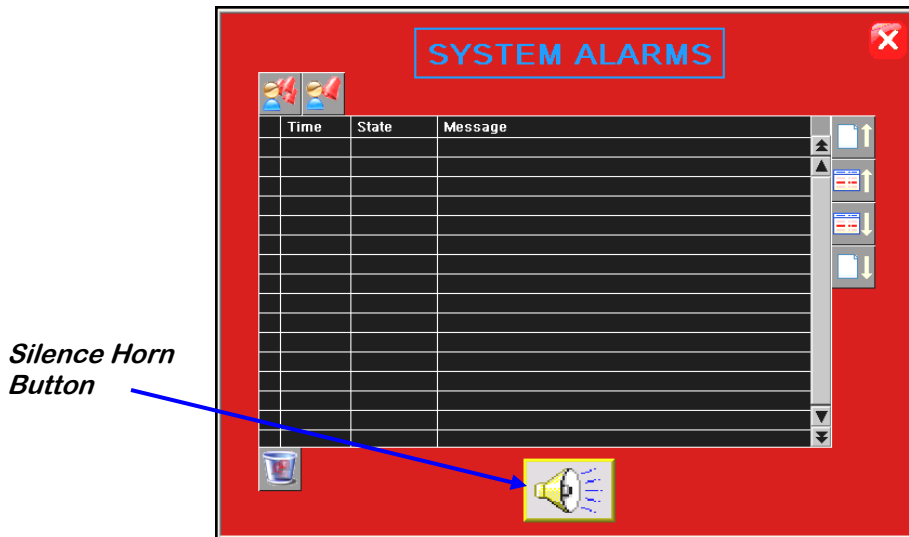

Alarm - Fault	Possible Cause	Solution
Underbin Conveyor Motor Fault	<ol style="list-style-type: none"> Underbin Conveyor motor auxiliary contact was not sensed after being energized to run. Underbin Conveyor motor has been shutdown while in Auto mode of operation. 	<ol style="list-style-type: none"> Verify that the motor starter has power, is turned on and that the overload is not tripped. Verify that the Underbin Conveyor was not turned “Off” while the system was in Auto mode of operation.
Weigh Hopper Reached Max Capacity	The current weight in the Weigh Hopper is above the number entered into the maximum scale weight in the “Utilities” screen.	Verify the number entered into the maximum scale weight box is correct. If yes, then recalibrate and rerun system.

BIN SITE SYSTEM

Alarm - Fault	Possible Cause	Solution
Scale Fill Conveyor Motor Fault	<ol style="list-style-type: none"> 1. Scale Fill Conveyor motor auxiliary contact was not sensed after being energized to run. 2. Scale Fill Conveyor motor has been shutdown while in Auto mode of operation. 	<ol style="list-style-type: none"> 1. Verify that the motor starter has power, is turned on and that the overload is not tripped. 2. Verify that the Scale Fill Conveyor was not turned "Off" while the system was in Auto mode of operation.
Transition Conveyor Motor Fault	<ol style="list-style-type: none"> 1. Transition Conveyor motor auxiliary contact was not sensed after being energized to run. 2. Transition Conveyor motor has been shutdown while in Auto mode of operation. 	<ol style="list-style-type: none"> 1. Verify that the motor starter has power, is turned on and that the overload is not tripped. 2. Verify that the Transition Conveyor was not turned "Off" while the system was in Auto mode of operation.
Transfer Conveyor Motor Fault	Transfer Conveyor motor auxiliary contact was not sensed after being energized to run.	Verify that the motor starter has power and is turned on.
Bin Site SURGE SUPPRESSOR-FAILED!!!	L1 of the Surge protector will no longer protect the electrical panel against voltage surges.	Replace the Surge Protector.
Underbin Conveyor - check for belt slippage/check speed sensor	<ol style="list-style-type: none"> 1. Underbin Conveyor belt is slipping. 2. Underbin Conveyor Speed is sensor is not working correctly. 	<ol style="list-style-type: none"> 1. Tighten and adjust the Underbin Conveyor belt as necessary. 2. Verify that sensor is tight to shaft and wiring is correct. If yes to both, then replace sensor.
Weigh Hopper Gate - Not Open	<ol style="list-style-type: none"> 1. "Open" slide gate sensor is not positioned properly. 2. "Open" slide gate solenoid failed to actuate. 	<ol style="list-style-type: none"> 1. Verify that the "open" slide gate sensor is properly positioned. 2. Check air supply and signal to solenoid.
Weigh Hopper Gate - Not Closed	<ol style="list-style-type: none"> 1. "Closed" slide gate sensor is not positioned properly. 2. "Closed" slide gate solenoid failed to actuate. 	<ol style="list-style-type: none"> 1. Verify that the "Closed" slide gate sensor is properly positioned. 2. Check air supply and signal to solenoid.

PAUSED CONTROLLED WARNING

The table below provides a general description of all the system warnings that could occur which would cause the system to pause. When a warning condition is detected, a window will pop-up notifying the operator that the system is “paused” because of a certain condition (below). When the condition has been corrected, the “CONTINUE” button can be pressed to restart the system. If the problem cannot be corrected, the “SHUTDOWN” button can be pressed. These messages will only appear if the Bin Site System is connected to a PLC controlled seed treater.

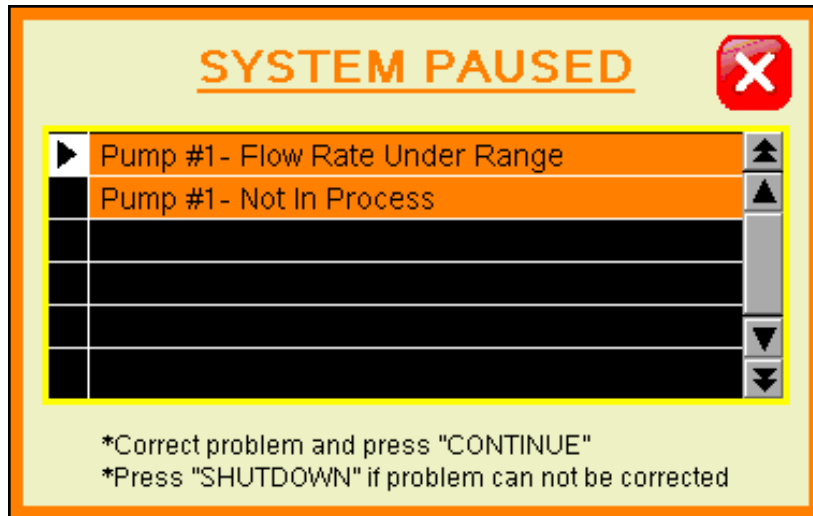

Warning	Possible Cause	Solution
Pump Flow Rate Under Range.	Actual flow rate is under 80% of target flow rate.	Check for empty supply tanks, worn or obstructed hoses, etc. that would cause a loss of liquid flow.
Pump Not In Process	Valve of the liquid displayed failed to divert to process when requested	Verify valve has diverted, if so troubleshoot sensor, if not, check air supply and signal to valve.

SYSTEM MESSAGES

The table below provides a general description of all the system messages that could occur. When a warning condition is detected, a window will appear (below) notifying the operator that the system will not start because of a certain condition. When the condition has been corrected, the “START SCALE FILL” button can be pressed to start the system.

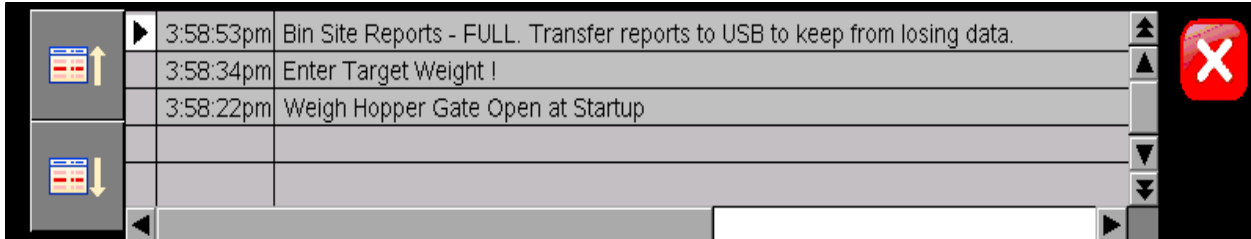

Message
Scale Fill Conveyor Not In Auto For Startup
Transition Conveyor Not In Auto For Startup:
Underbin Conveyor Not In Auto For Startup
Diverter in Treat position at Startup
Weigh Hopper Gate Open at Startup
Enter Target Weight!
Scale Unstable - Stabilize scale to continue operation.
Diverter in Bypass Position at Startup
Bin Site Reports - FULL. Transfer Reports to USB to keep from losing data.
Treater Auto Start Failed - Correct problem and press the Treater Startup button.
BIN SITE SYSTEM CONFIGURATION ERROR. Please contact USC tech support.
Transfer Conveyor Not in Auto For Startup.
Please select desired Bin for Startup.
Scale Fill Manual in Operation.

SECTION
G**MAINTENANCE**

Proper maintenance of your bin site system is critical for peak performance, reliability and accuracy of this system. The following is a guideline for the type of maintenance and servicing that should be performed on this unit. Your environment and uses may require additional maintenance and service beyond this list to assure a reliable and safe unit. The operator of this unit has ultimate responsibility to identify areas of concern and rectify them before they become a hazard or safety issue. There is no substitute for a trained, alert operator.



Do not put this unit into operation with any questionably maintained parts. Poor performance or a hazard may occur.

BIN SLIDE GATES

- Inspect all welds and structural components for bends, cracks and damage.
- Test slide gates for proper actuation with control panel.
- Remove air to gates and manually open and close gates. Check for any friction while gate is sliding.

UNDERBIN CONVEYOR

- Inspect all welds and structural components for bends, cracks and damage.
- Clean out any build up of debris from the clean out door.
- Check the conveyor belt tension and alignment. (page 65)
- Check the drive belt tension and alignment. (page 67)
- Grease all necessary bearings.
- Remove yellow guard and check chain tension.
- Check for proper operation of conveyor while in reverse mode. Align if necessary.
- Check counter for tightness to shaft and proper signal to control panel.

SCALE FILL CONVEYOR

- Inspect all welds and structural components for bends, cracks and damage.
- Clean out any build up of debris from the clean out door.
- Check the conveyor belt tension and alignment. (page 65)
- Check the drive belt tension and alignment. (page 67)
- Grease all necessary bearings.
- Remove yellow guard and check chain tension.

WEIGH HOPPER, SLIDE GATE & SCALE HEAD

- Inspect all welds and structural components for bends, cracks and damage.
 - Check for binding on scale components.
 - Check wiring from scale to scale head for any damage or kinks.
 - Test slide gate for proper actuation with control panel.
 - Check slide gate sensors for correct positioning and signal.
 - Have scale professionally re-calibrated as necessary.
-

CONTROL PANEL & AIR SYSTEM

- Drain water from air system.
 - Check air dryer as necessary.
 - Test all air solenoids for correct actuation.
 - Inspect all exterior wiring for any kinks or damage.
-

PRO BOX HOPPER & TRANSFER CONVEYOR (optional)

- Inspect all welds and structural components for bends, cracks, and damage.
 - Clean out any build up of debris from the clean out door.
 - Check the conveyor belt tension and alignment. (page 65)
 - Check the drive belt tension and alignment. (page 67)
 - Grease all necessary bearings.
 - Remove yellow guard and check chain tension.
-

DIVERTER (optional)

- Inspect all welds and structural components for bends, cracks, and damage.
 - Test diverter gate for proper actuation with control panel.
 - Clean diverter tubing of any obstructions.
 - Grease all necessary bearings.
-

TRANSFER CONVEYOR (optional)

- Inspect all welds and structural components for bends, cracks and damage.
- Clean out any build up of debris from the clean out door.
- Check the conveyor belt tension and alignment. (page 65)
- Check the drive belt tension and alignment. (page 67)
- Grease all necessary bearings.
- Remove yellow guard and check chain tension.

CONVEYING BELT TENSION AND ALIGNMENT

The tension and alignment of the belt should be checked weekly, or more often if required, to be sure that it does not slip or run to one side. A properly tensioned belt will not slip when it is operating. Operating the belt with less slippage will increase the belt life and causes less stress on bearings, pulleys and shafts.

To maintain the belt, follow this procedure:

NOTICE Place all controls in neutral or off, stop motor and disable power source before working on belt.

1. Use the take-up bolts located at the tail to set the tension of the belting.
2. If the belt needs to be tightened to prevent slippage, use the take-up adjustments on the tail end only.
3. The belt is tightened by turning both take-up adjustments an **equal** number of turns.
4. Use the drive roller to check the alignment. The belt should be centered.
5. Turn the belt 1/2 revolution when the belt is new and check the drive and tail roller. If out of alignment, the belt will move to the loose side. Loosen the bearing mounting bolts and use the bearing position bolts to set the position. Tighten mounting bolts.
6. Run and check again. Check frequently during the first few minutes of operation and then several times during the first 10 hours. The belt normally seats itself during the first 10 hours of operation and can be checked weekly after that.
7. The belt is properly aligned when the belt runs in the center of the head and tail rollers.

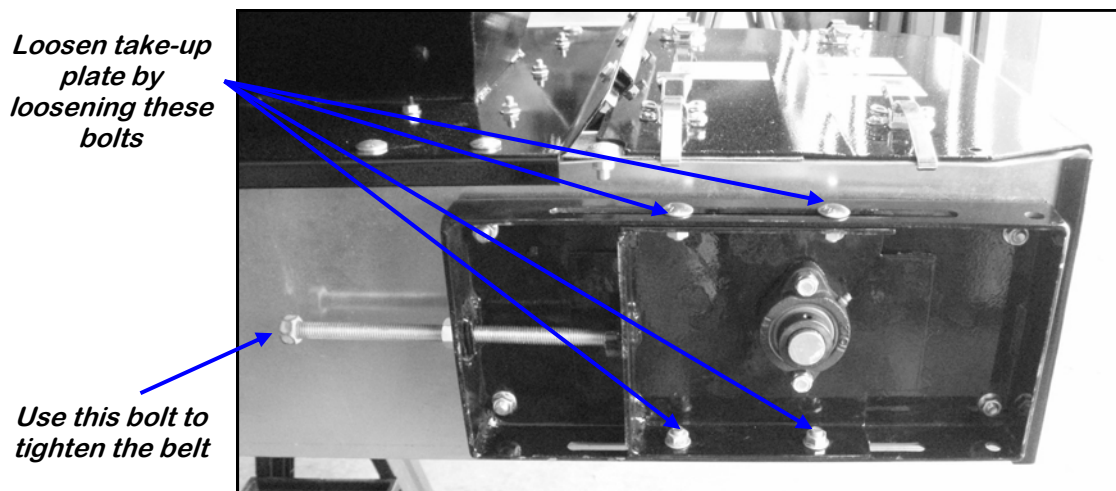

CONVEYING BELT ALIGNMENT

1. A misaligned belt will track toward the loose side. Set the tracking by loosening the bearing mounts on the tight side and using the bearing position bolt to move the end of the head roller toward the tail. Tighten the bearing mount when the belt is centered on the head roller.
2. Run the belt and check the tracking again. Loosen the tight side slightly again if required. Repeat the adjusting and checking procedure until the belt centers on the input end roller and remains centered when running.
3. Always repeat this aligning procedure when installing a new belt. Check frequently during the first 10 hours of operation. After 10 hours, the belt is normally seated and checking the alignment can be done less frequently.



Loosen bearings



Adjusting tracking

BELT REPLACEMENT

1. Rotate the belt until the seam is visible.
2. Move the tail roller to its loosest position.
3. Pull all the slack to the seam area.
4. Remove the wire connector and open the belt.
5. Attach one end of the replacement belt to the belt end being removed.
6. Pull the old belt out and the new belt will be threaded into place.
7. Disconnect the old belt.
8. Connect the ends of the new belt together and secure.
9. Set the belt tension.
10. Check and set the belt alignment

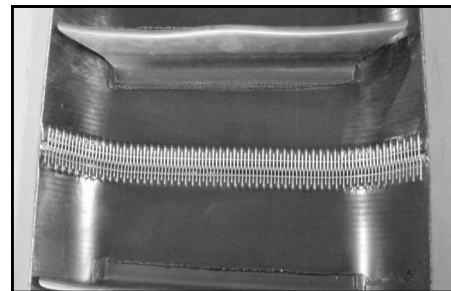

Belt Seam



Check alignment

DRIVE BELT TENSION & ALIGNMENT

Power to the conveying belt is transmitted through a V-belt. The V-belt drive system must be maintained at the proper belt tension and pulley alignment to obtain the desired performance and life. When maintaining the belt drive system for the electric drive model, follow this procedure:

NOTICE Turn motor off and unplug power cord or turn off power and lock out the master panel before starting maintenance on drive belt system.

Drive Belt Tension

1. Push on the center of the belt span with a force of approximately 5 to 10 lbs.
2. The belts will deflect approximately 1/4 to 1/2 inch when properly tensioned.
3. Move the motor up, using the adjustment bolts, to set drive belt tension (right).
4. Close and secure guards.



Motor base adjustment

Drive Belt Alignment

1. Lay a straightedge across the pulley faces to check the alignment (right).
2. Use the pulley hub or the motor mounting plate slots to move the pulley to the required position for alignment.
3. Tighten hub bolts to secure pulley on shaft.
4. Check belt tension
5. Close and secure guards.



Lay a straightedge across pulley faces

Drive Belt Replacement

1. Lower motor to its loosest position.
2. Remove old belt and replace with a new one.
3. Raise motor to set the belt tension.
4. Check pulley alignment. Adjust if required.
5. Close and secure guards.

When storing the USC Bin Site System for long periods of time, the following procedures must be followed to reduce the chance of rust, corrosion and fatigue of the Bin Site System. You can also use these steps when storing the machine for the winter.



A dust mask and protective rubber gloves shall be used when cleaning the machine.

UNDERBIN CONVEYOR

1. Disconnect power.
2. Thoroughly wash the entire machine to remove all dirt, mud, debris or residue.
3. Remove yellow covers and remove any debris or build-up.
4. Remove clean out doors and thoroughly remove any debris or build-up inside of the conveyor. Ensure that the bottom pan of the underbin conveyor is free of seed.
5. Lubricate all grease fittings and chain. Make sure that all grease cavities have been filled with grease to remove any water residue from the washing. This also protects the bearing seals.
6. Re-connect power and run the underbin conveyor to help remove any additional debris. Compressed air can be used to blow out any foreign material.
7. Cover the electric motor with a water proof tarpaulin and tie securely in place.

WEIGH HOPPER & SLIDE GATE

1. Thoroughly clean the weigh hopper to remove all residue from the equipment.
2. Clean the slide gate of any seed or residue that may have built up.

SCALE FILL CONVEYOR

1. Disconnect power.
 2. Thoroughly wash the entire machine to remove all dirt, mud, debris or residue.
 3. Remove yellow covers and remove any debris or build-up.
 4. Remove clean out doors and thoroughly remove any debris or build-up inside of the conveyor.
 5. Lubricate all grease fittings and chain. Make sure that all grease cavities have been filled with grease to remove any water residue from the washing. This also protects the bearing seals.
 6. Re-connect power and run the scale fill conveyor to help remove any additional debris. Compressed air can be used to blow out any foreign material.
 7. Cover the electric motor with a water proof tarpaulin and tie securely in place.
-

PRO BOX HOPPER & TRANSFER CONVEYOR (optional)

1. Disconnect power.
2. Thoroughly wash the entire machine to remove all dirt, mud, debris or residue.
3. Remove yellow covers and remove any debris or build-up.
4. Remove clean out doors and thoroughly remove any debris or build-up inside of the conveyor.
5. Lubricate all grease fittings and chain. Make sure that all grease cavities have been filled with grease to remove any water residue from the washing. This also protects the bearing seals.
6. Re-connect power and the transfer conveyor to help remove any additional debris. Compressed air can be used to blow out any foreign material.
7. Cover the electric motor with a water proof tarpaulin and tie securely in place.
8. Tarp or place the cover on top of the pro box hopper to keep out any dirt or unwanted pests.

FINAL

1. Store all portable components of the bin site system inside a protective building to keep them from being exposed to the weather.
2. Disconnect power to the machine and all of the components.
3. Ensure all moisture has been removed from the airlines.
4. Disconnect the supply air line to the bottom of the solenoid bank and place a plug in the fitting to keep moisture out of the system.

SECTION
I

MECHANICAL DRAWINGS

The following pages show the parts for the 300 and 100 unit weigh hoppers. Please have the part number ready when ordering parts.

300 Unit Weigh Hopper

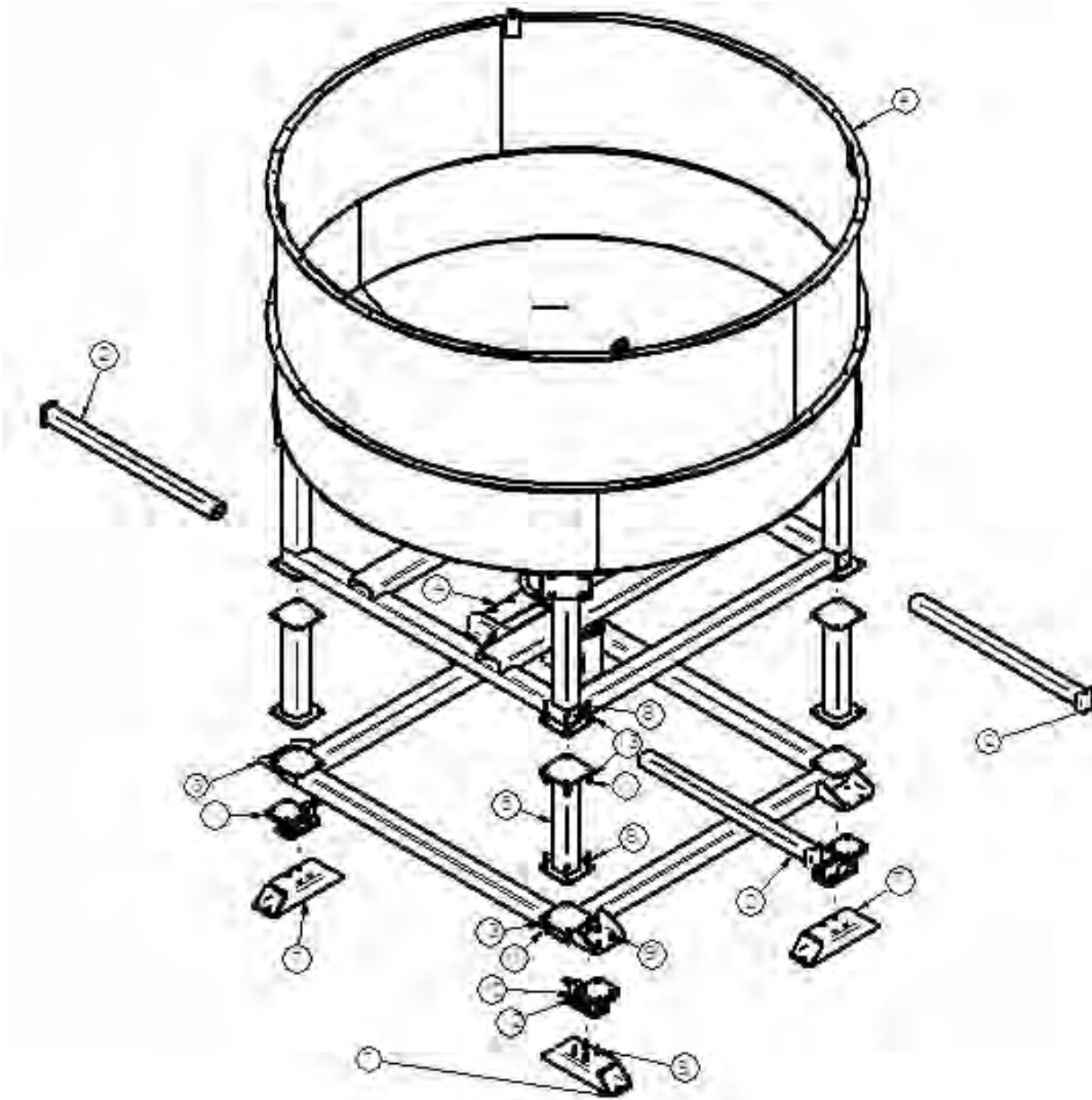

300 Unit Weigh Hopper Parts List

<u>Item #</u>	<u>Part #</u>	<u>Title</u>	<u>Qty</u>
1	03-19-0036	LDCL 5000LB X4 KIT	1
2	05-03-0810	WDMT SCL WEIGHT HANGER	4
3	05-03-0870	WDMT BASE FR LDCL MNT 76IN CTRS	1
4	05-07-0297	ASSY WEIGHT HOPP 300 UNIT SLGT	1
5	05-07-0307	ASSY WEIGH HOPP FR 24 OAL FS-3	1
6*	05-08-0153	SHIM KIT WEIGH HOPPER LDCL	1
7	05-11-0285	BASE MNT LDCL WGH HOPP FR	4
8	06-01-0032	BOLT, .625 X 11 X 2" UNC ZP GRADE 5	32
9	06-01-0075	BOLT, .625 X 11 X 2.50" UNC ZP GRADE 5	32
10	06-02-0005	NUT, .625-11 UNC ZP GRADE 5	32
11	06-03-0005	NUT NYL LOCK .625-11 ZP	32
12	06-04-0005	WASHER, .625 LOCK ZP	32
13	06-05-0006	WASHER, .625 FLAT ZP	48
14	12-04-0017	SLIDE GATE WEIGHT HOPP 8.00	1

100 Unit Weigh Hopper

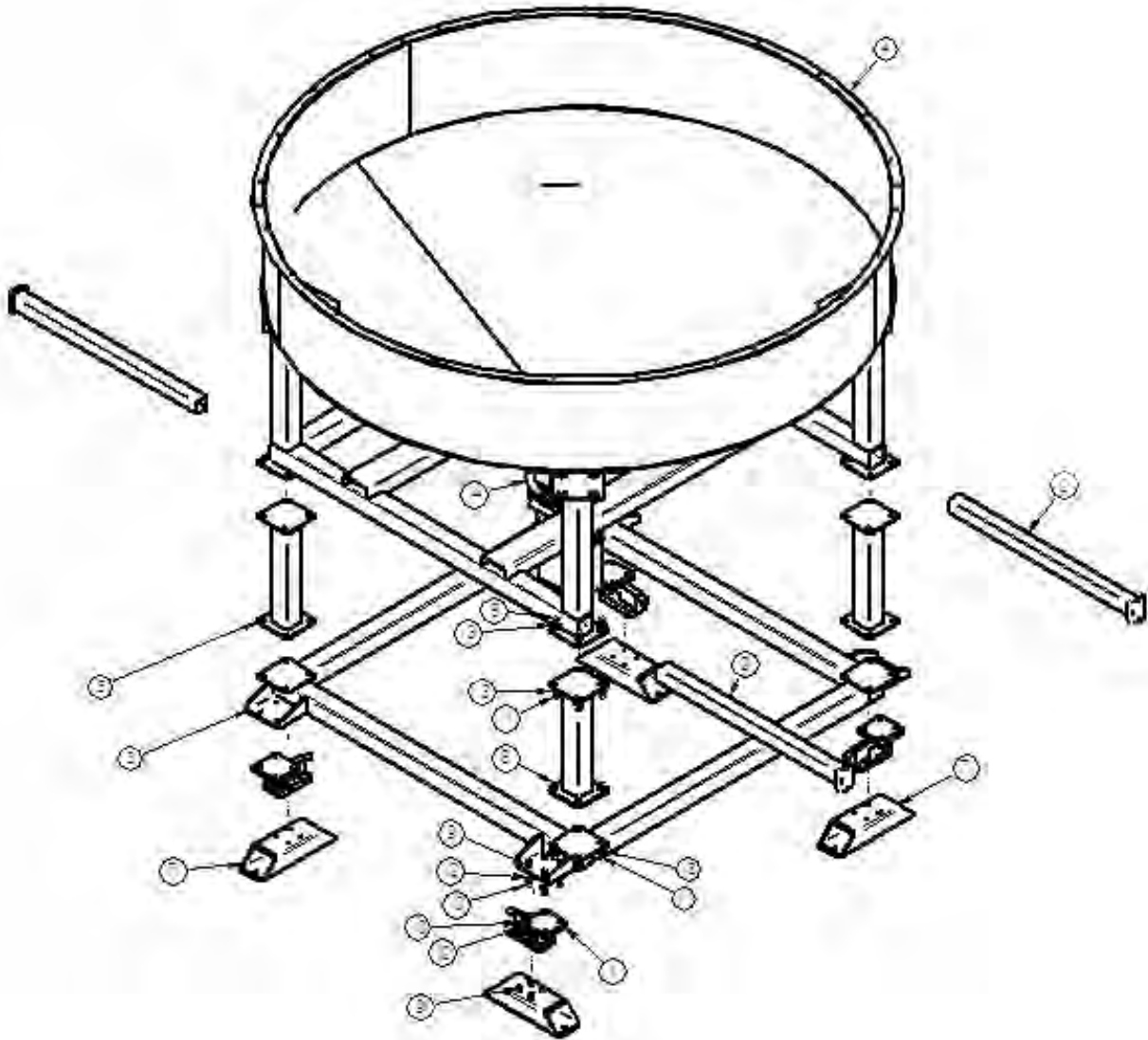

100 Unit Weigh Hopper Parts List

<u>Item #</u>	<u>Part #</u>	<u>Title</u>	<u>Qty</u>
1	03-19-0036	LDCL 5000LB X4 KIT	1
2	05-03-0810	WDMT SCL WEIGHT HANGER	4
3	05-03-0870	WDMT BASE FR LDCL MNT 76IN CTRS	1
4	05-07-0296	ASSY WEIGHT HOPP 100-200 UNIT SLGT	1
5	05-07-0307	ASSY WEIGH HOPP FR 24 OAL FS-3	1
6*	05-08-0153	SHIM KIT WEIGH HOPPER LDCL	1
7	05-11-0285	BASE MNT LDCL WGH HOPP FR	4
8	06-01-0032	BOLT, .625 X 11 X 2" UNC ZP GRADE 5	32
9	06-01-0075	BOLT, .625 X 11 X 2.50" UNC ZP GRADE 5	32
10	06-02-0005	NUT, .625-11 UNC ZP GRADE 5	32
11	06-03-0005	NUT NYL LOCK .625-11 ZP	32
12	06-04-0005	WASHER, .625 LOCK ZP	32
13	06-05-0006	WASHER, .625 FLAT ZP	48
14	12-04-0017	SLIDE GATE WEIGHT HOPP 8.00	1

SECTION
J**LIMITED WARRANTY**

USC, LLC, (Manufacturer) warrants its seed treating equipment as follows:

1. **Limited Warranty:** Manufacturer warrants that the Products sold hereunder will be free from defects in material and workmanship for a period of 12 months from date of shipment. If the Products do not conform to this Limited Warranty during the warranty period, Buyer shall notify Manufacturer in writing of the claimed defects and demonstrate to Manufacturer satisfaction that said defects are covered by this Limited Warranty. If the defects are properly reported to Manufacturer within the warranty period, and the defects are of such type and nature as to be covered by this warranty, Manufacturer shall, at its expense, furnish replacement Products or, at Manufacturer's option, replacement parts for the defective products. Shipping and installation of the replacement Products or replacement parts shall be at the Buyer's expense.

2. **Other Limits:** THE FOREGOING IS IN LIEU OF ALL OTHER WARRANTIES, EXPRESSED OR IMPLIED, INCLUDING BUT NOT LIMITED TO THE IMPLIED WARRANTIES OF MERCHANTABILITY AND FITNESS FOR A PARTICULAR PURPOSE. Manufacturer does not warrant against damages or defects arising from improper installation (where installation is by persons other than Manufacturer), against defects in products or components not manufactured by Manufacturer, or against damages resulting from such non-Manufacturer made products or components. Manufacturer passes on to the Buyer the warranty it received (if any) from the maker of such non-Manufacturer made products or components. This warranty also does not apply to Products upon which repairs and/or modifications have been effected or attempted by persons other than pursuant to written authorization by Manufacturer. Manufacturer does not warrant against casualties or damages resulting from misuse and/or abuse of product(s), acts of nature, effects of weather, including effects of weather due to outside storage, accidents, or damages incurred during transportation by common carrier.

3. **Exclusive Obligation:** THIS WARRANTY IS EXCLUSIVE. The sole and exclusive obligation of Manufacturer shall be to repair or replace the defective Products in the manner and for the period provided above. Manufacturer shall not have any other obligation with respect to the Products or any part thereof, whether based on contract, tort, strict liability or otherwise. Under no circumstances, whether based on this Limited Warranty or otherwise, shall Manufacturer be liable for incidental, special, or consequential damages.

4. **Other Statements:** Manufacturer's employees or representatives' oral or other written statements do not constitute warranties, shall not be relied upon by Buyer, and are not a part of the contract for sale or this limited warranty.

5. **Return Policy:** Approval is required prior to returning goods to USC, LLC. A restocking fee will apply.

6. **Entire Obligation:** This Limited Warranty states the entire obligation of Manufacturer with respect to the Products. If any part of this Limited Warranty is determined to be void or illegal, the remainder shall remain in full force and effect.



USC, LLC

2320 124th road

Sabetha, Ks 66534

PHONE: (785) 431-7900

FAX: (785) 431-7950

EMAIL: sales-team@uscllc.com

WEB: www.uscllc.com
