

LPV SEED TREATER

Operators Manual

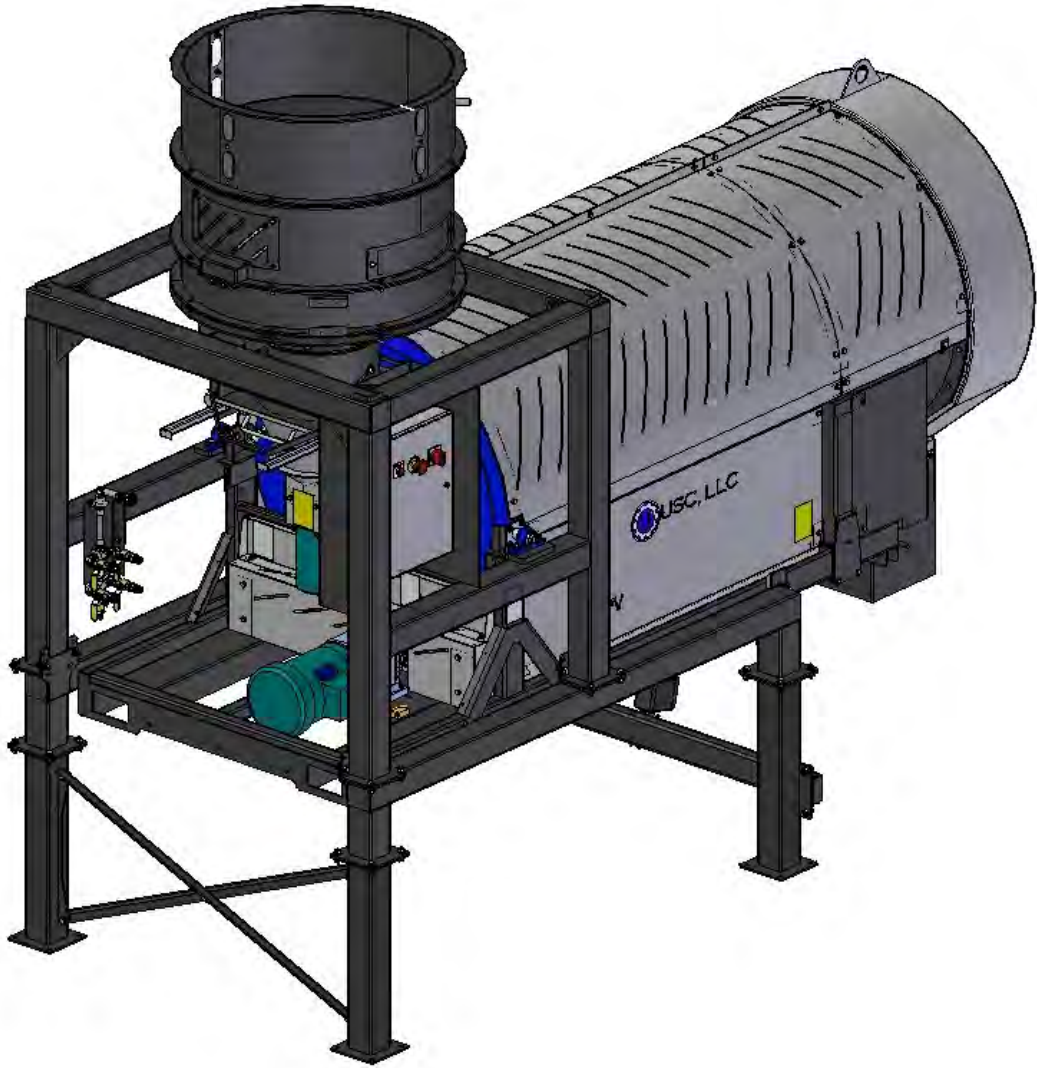

Document: TD-09-06-1028

Revision: B



INTRODUCTION

Thank you for choosing USC, LLC for your equipment needs. We appreciate your business and will work diligently to ensure that you are satisfied with your choice.

OVERVIEW

The purpose of this manual is to provide you with the basic information needed to operate and maintain the LPV Seed Treater. It does not hold USC, LLC liable for any accidents or injuries that may occur.

The technical information provided in this document is based on extensive testing under controlled conditions at the USC research and development facility. This information is given without guarantee as the conditions of operation and storage of the equipment are beyond our control. Variables such as temperature, humidity, viscosity of chemical products and changes in seed size or variety may all effect the accuracy of application and seed coverage. Periodically check the equipment calibration while treating and make adjustments as required. This will insure the optimum seed coverage.

OPERATOR RESPONSIBILITIES

As the purchaser/owner/operator of this equipment and control system, you have an obligation to install, operate, and maintain the equipment in a manner that minimizes the exposure of people in your care to any potential hazards inherent in using this equipment. It is critical that the owner of this equipment:

- Has a clear and documented understanding of the process this machine is being used in and of any resulting hazards or special requirements arising from this specific application.
- Allow only properly trained and instructed personnel to install, operate or service this equipment.
- Maintain a comprehensive safety program involving all who work with this machine and other associated process equipment.
- Establish clear areas of staff responsibility (e.g. operation, setup, sanitation, maintenance, and repairs).
- Provide all personnel with necessary safety equipment.
- Periodically inspect the equipment to insure that the doors, covers, guards, and safety devices are in place and functioning, that all safety instructions and warning labels are intact and legible, and that the equipment is in good working order.
- In addition to the operating instructions, observe and enforce the applicable legal and other binding regulations, national and local codes.

TABLE OF CONTENTS

<u>Section</u>	<u>Contents</u>	<u>Page #</u>
Section A	Safety Instructions.....	5
Section B	Installation	17
	LPV Automated Treater Set-up	18
Section C	Mechanical Operation.....	28
	LPV Treater with Seed Wheel Overview	28
	LPV Treater with Loss-in-Weight Overview	29
	Seed Wheel Overview.....	30
	Seed Wheel with Atomizer Chamber Overview.....	31
	Loss-in-Weight Atomizer Chamber Overview.....	32
	Rotating Drum Overview.....	34
Section D	Electrical Operation	35
Section E	Calibration	37
	Determining Seed Cup Weight	37
	Adjusting Manual Seed Flow Gate.....	38
Section F	Troubleshooting.....	40
	Proximity Switch Adjustment Guide	42
Section G	Maintenance	43
Section H	Storage.....	48
Section I	Mechanical Drawings	51
Section J	Limited Warranty.....	107

SAFETY INSTRUCTIONS

SECTION A

Every year accidents in the work place maim, kill and injure people. Although it may be impossible to prevent all accidents, with the right combination of training, operating practices, safety devices, and operator vigilance, the number of accidents can be significantly reduced. The purpose of this section is to educate equipment users about hazards, unsafe practices, and recommended hazard avoidance techniques.

If any of the required regularly scheduled maintenance is located above the reach of the operator, they should follow the companies normal safe practices of reaching that particular height, utilizing the companies specified equipment and following normal safety precautions.

When working with treatment chemicals, operators should always wear protective gloves, safety glasses, and follow the companies safety precautions in the case of any spillage or operator contamination.

SAFETY WORDS AND SYMBOLS

It is very important that operators and maintenance personnel understand the words and symbols that are used to communicate safety information. Safety words, their meaning and format, have been standardized for U.S. manufacturers and published by the American National Standards Institute (ANSI). The European Community (E.C.) has adopted a different format based on the International Standards Organization (I.S.O.) and applicable machinery directives. Both formats are presented below. Graphic symbols are not standardized, but most manufacturers will use some variation of the ones seen in this manual.

MOTS ET SYMBOLES SÉCURITÉ

Il est très important que les opérateurs et le personnel d'entretien à comprendre les mots et les symboles qui sont utilisés pour communiquer des informations de sécurité. Mots de sécurité, de leur signification et le format, ont été normalisés pour les fabricants américains et publié par l' American National Standards Institute (ANSI). La Communauté européenne (CE) a adopté un format différent sur la base de l'Organisation internationale de normalisation (ISO) et des directives de machines applicables. Les deux formats sont présentés ci-dessous. Les symboles graphiques ne sont pas standardisés, mais la plupart des fabricants utilisent une variante de ceux observés dans ce manuel.



Indicates an imminently hazardous situation which, if not avoided, **will** result in death or serious injury.



Indique une situation extrêmement dangereuse qui, si pas évitée, entraînera la mort ou des blessures graves.



Indicates a potentially hazardous situation which, if not avoided, **could** result in death or serious injury.



Indique une situation potentiellement dangereuse qui, si pas évitée, pourrait entraîner la mort ou des blessures graves.



Indicates a potentially hazardous situation which, if not avoided, **may** result in minor or moderate injury and/or property damage.



Indique une situation potentiellement dangereuse qui, si pas évitée, peut entraîner des blessures mineures ou modérées et / ou des dommages.



Provides additional information that the operator needs to be aware of to avoid a potentially hazardous situation.



Fournit des informations supplémentaires que l'opérateur doit être conscient de d'éviter une situation potentiellement dangereuse.



Notice is used to notify people of important installation, operation or maintenance information which is not hazard related.



Avis est utilisé pour informer les gens des informations de maintenance qui ne est pas danger lié importante installation, l'exploitation ou.



Mandatory Lockout Power Symbol. Disconnect, lockout and tagout electrical and other energy sources before inspecting, cleaning or performing maintenance on this panel.

Symbole de puissance verrouillage obligatoire. Débranchez, de verrouillage et de déconsignation énergie électrique et d'autres sources avant d'inspecter, de nettoyage ou de la maintenance de ce panneau.



International Safety Alert Symbol. The exclamation point (!) surrounded by a yellow triangle indicates that an injury hazard exists. However, it does not indicate the seriousness of potential injury. The exclamation point (!) is also used with the DANGER, WARNING and CAUTION symbols so the potential injury is indicated.

Sécurité Symbole International Alert . Le point d'exclamation (!) Entouré par un triangle jaune indique que un risque de blessure existe . Cependant, il ne indique pas la gravité des blessures potentielles. Le point d'exclamation (!) Est également utilisé avec les symboles DANGER, AVERTISSEMENT et ATTENTION de sorte que le risque de blessure est indiqué.



Electrocution Hazard Symbol. This symbol indicates that an electrocution hazard exists. Serious injury or death could result from contacting high voltage.

Symbole de danger d'électrocution . Ce symbole indique qu'un danger d'électrocution existe. Des blessures graves ou la mort pourraient résulter de contact haute tension.



International Electrocution Hazard. This symbol indicates that an electrocution hazard exists. Serious injury or death could result from contacting high voltage.

Danger d'électrocution international. Ce symbole indique qu'un danger d'électrocution existe. Des blessures graves ou la mort pourraient résulter de contact haute tension.



Mandatory Read Manual Action Symbol. (I.S.O. format) This symbol instructs personnel to read the Operators Manual before servicing or operating the equipment.

Obligatoire Lire Symbole d'action Manuel. (Format ISO)
Ce symbole indique le personnel de lire le manuel de l'opérateur avant de réparer ou d'utiliser l'équipement.



Mandatory Read Manual Action Symbol. This symbol instructs personnel to read the Operators Manual before servicing or operating the equipment.

Obligatoire Lire Symbole d'action Manuel . Ce symbole indique le personnel de lire le manuel de l'opérateur avant de réparer ou d'utiliser l'équipement.

LOCKOUT / TAGOUT PROCEDURES

Lockout/Tagout is the placement of a lock/tag on an energy isolating device in accordance with an established procedure. When taking equipment out of service to perform maintenance or repair work, always follow the lockout / tagout procedures as outlined in ANSI Z344.1 and/or OSHA Standard 1910.147. This standard “requires employers to establish a program and utilize procedures for affixing appropriate lockout devices or tagout devices to energy isolating devices and to otherwise disable machines or equipment to prevent unexpected energizing, start-up, or release of stored energy in order to prevent injury to employees.”

LES PROCEDURES DE VERROUILLAGE / ETIQUETAGE

Verrouillage / étiquetage est le placement d'un verrouillage / tag sur un dispositif d'isolement de l'énergie conformément à une procédure établie. Lors de la prise hors service des équipements pour effectuer la maintenance ou de réparation, toujours suivre les procédures de verrouillage / débranchement comme indiqué dans la norme ANSI Z344.1 et / ou la norme OSHA 1910.147. Cette norme "oblige les employeurs à établir un programme et appliquer des procédures pour la fixation des dispositifs de verrouillage appropriés ou des dispositifs déconsignation à l'énergie dispositifs d'isolement et d' autre machines ou équipements désactiver pour éviter énergisant inattendu, start-up, ou la libération de l'énergie stockée dans le but de prévenir les blessures aux employés."

EMERGENCY STOP



There is an Emergency Stop push button on all LPV Seed Treaters which is located on the Treater Control Panel. The LPV Automated Treater has an additional Emergency Stop pushbutton on the Main Control Panel. Actuators of emergency stop shall be colored RED. The background immediately around the device actuator shall be colored YELLOW. The actuator pushbutton operated device shall be of the palm or mushroom head type.

ARRET D'URGENCE

Il ya un bouton-poussoir d'arrêt d'urgence sur tous les traiteurs de semences LPV qui est situé sur le Panneau de configuration Traiteur. Le LPV automatisé Traiteur dispose d'une autre arrêt d'urgence bouton poussoir sur le panneau de commande principal. Actionneurs de freinage d'urgence doivent être de couleur rouge. Le fond immédiatement autour de l'actionneur de l'appareil doit être de couleur JAUNE. Le dispositif actionné actionneur de bouton-poussoir doit être de la paume ou champignons type de tête.

CONTROLLED STOP

This is the stopping of machine motion by reducing the electrical command signal to 0 (zero) once the stop signal has been recognized.

ARRET CONTROLÉ

Ce est l'arrêt du mouvement de la machine en réduisant le signal de commande électrique à 0 (zéro) dès que le signal d'arrêt a été reconnu.

HAZARD REVIEW

RISQUE EXAMEN



Electrocution Hazard

Electrocution accidents are most likely to occur during maintenance of the electrical system or when working on or near exposed high voltage wiring. This hazard does not exist when the electrical power has been disconnected, properly locked, and tagged out.

Risque d'électrocution

Les accidents d'électrocution sont les plus susceptibles de se produire lors de la maintenance du système électrique ou pour travailler sur ou à proximité du câblage haute tension exposé. Ne existe pas ce danger lorsque l'alimentation électrique a été déconnecté, bien verrouillé et étiquetés sur.

Automatic Start Hazard



! WARNING

This equipment may be controlled by an automated system and may start without warning. Failure to properly disconnect, lockout, and tagout all energy sources of remotely controlled equipment creates a very hazardous situation and could cause injury or even death. PLEASE STAY CLEAR AND BE ALERT.

Démarrer danger automatique

! AVERTISSEMENT

Cet équipement peut être contrôlé par un système automatisé et peut démarrer sans avertissement. Sources de l'équipement contrôlé à distance non débranché correctement, lock-out, et tous déconsignation énergie crée une situation très dangereuse et pourrait causer des blessures ou même la mort. Se IL VOUS PLAÎT rester à l'écart et d'être vigilant.

LPV SEED TREATER

YOU are responsible for the **SAFE** operation and maintenance of your USC, LLC equipment . **YOU** must ensure that you and anyone else who is going to operate, maintain or work around the equipment be familiar with the operating and maintenance procedures and related **SAFETY** information contained in this manual. This manual will take you step-by-step through your working day and alert you to good safety practices that should be adhered to while operating the equipment

Remember, **YOU** are the key to safety. Good safety practices not only protect you, but also the people around you. Make these practices a working part of your safety program. Be certain that **EVERYONE** operating this equipment is familiar with the recommended operating and maintenance procedures and follows all the safety precautions. Most accidents can be prevented. Do not risk injury or death by ignoring good safety practices.

- Equipment owners must give operating instructions to operators or employees before allowing them to operate the machine, and at least annually thereafter per OSHA (Occupational Safety and Health Administration) regulation 1928.57.
- The most important safety device on this equipment is a **SAFE** operator. It is the operator's responsibility to read and understand **ALL** Safety and Operating instructions in the manual and to follow them. All accidents can be avoided.
- A person who has not read and understood all operating and safety instructions is not qualified to operate the machine. An untrained operator exposes himself and bystanders to possible serious injury or death.
- Do not modify the equipment in any way. Unauthorized modification may impair the function and/or safety and could affect the life of the equipment.
- Think SAFETY! Work SAFELY!

GENERAL SAFETY

1. Read and understand the operator's manual and all safety labels before operating, maintaining, adjusting or unplugging the equipment .
2. Only trained persons shall operate the equipment . An untrained operator is not qualified to operate the machine.
3. Have a first-aid kit available for use should the need arise, and know how to use it.



LPV SEED TREATER

4. Provide a fire extinguisher for use in case of an accident. Store in a highly visible place.
5. Do not allow children, spectators or bystanders within hazard area of machine.
6. Wear appropriate protective gear. This includes but is not limited to:
 - A hard hat
 - Protective shoes with slip resistant soles
 - Protective goggles
 - Heavy gloves
 - Hearing protection
 - Respirator or filter mask
7. Place all controls in neutral or off, stop motor, and wait for all moving parts to stop. Then disable power source before servicing, adjusting, repairing, or unplugging.
8. Review safety related items annually with all personnel who will be operating or maintaining the equipment.



OPERATING SAFETY:

1. Read and understand the Operator's Manual and all safety labels before using.
2. Disconnect and disable electrical supply completely and wait for all moving parts to stop before servicing, adjusting, repairing or unplugging.
3. Clear the area of bystanders, especially children, before starting.
4. Be familiar with the machine hazard area. If anyone enters hazard area, shut down machine immediately. Clear the area before restarting.
5. Keep hands, feet, hair and clothing away from all moving and/or rotating parts.
6. Stay away from overhead obstructions and power lines during operation and transporting. Electrocutation can occur without direct contact.
7. Do not operate machine when any guards are removed.
8. Inspect welds and repair if needed.

PLACEMENT SAFETY

1. Move only with the appropriate equipment
2. Stay away from overhead power lines when moving equipment. Electrocution can occur without direct contact.
3. Be familiar with machine hazard area. If anyone enters hazard areas, shut down machine immediately. Clear the area before restarting.
4. Operate the equipment on level ground free of debris. Anchor the equipment to prevent tipping or upending.



Before placement of the equipment, be sure that ground is reasonably level. The equipment may topple or work improperly if the ground is too uneven, damaging the equipment and / or causing personal injury.



Avant de placement de l'équipement, assurez-vous que sol est relativement plat. L'équipement peut tomber ou mal fonctionner si le sol est trop inégale, endommager l'équipement et / ou causer des blessures.

MAINTENANCE SAFETY

1. Review the operator's manual and all safety items before working with, maintaining or operating the equipment .
2. Place all controls in neutral or off, stop motors, disable power source, and wait for all moving parts to stop before servicing, adjusting, repairing or unplugging.
3. Follow good shop practices:
Keep service area clean and dry.
Be sure electrical outlets and tools are properly grounded.
Use adequate light for the job at hand.
4. Keep hands, feet, hair and clothing away from all moving and/or rotating parts.
5. Clear the area of bystanders, especially children, when carrying out any maintenance and repairs or making any adjustments.
6. Before resuming work, install and secure all guards when maintenance work is completed.
7. Keep safety labels clean. Replace any sign that is damaged or not clearly visible.



SAFETY LABELS

1. Keep safety labels clean and legible at all times.
2. Replace safety labels that are missing or have become illegible.
3. Replaced parts that displayed a safety label should also display the current label.
4. Replacement safety labels are available. Contact USC at (785) 431-7900 .

How to Install Safety Labels:

- Be sure that the installation area is clean and dry.
- Be sure temperature is above 50°F (10°C).
- Decide on the exact position before you remove the backing paper.
- Remove the smallest portion of the split backing paper.
- Align the sign over the specified area and carefully press the small portion with the exposed sticky backing in place.
- Slowly peel back the remaining paper and carefully smooth the remaining portion of the sign in place.
- Small air pockets can be pierced with a pin and smoothed out using the piece of sign backing paper.



Located on the USC equipment you will find safety labels. Always be sure to read and follow all directions on the labels.



Situé sur l'équipement USC vous trouverez des étiquettes de sécurité. Veuillez à toujours lire et suivre toutes les instructions sur les étiquettes.



Guards provided with USC equipment are to remain in place during operation.



Gardes fournis avec des équipements USC doivent rester en place pendant le fonctionnement.

Think **SAFETY!** Work **SAFELY!**

REMEMBER—If Safety Labels have been damaged, removed, become illegible, or parts replaced without safety labels, new labels must be applied. New safety labels are available from USC at (785) 431-7900.



Part # 09-02-0001



Part # 09-02-0003

LPV SEED TREATER



Part # 09-02-0002

Part # 09-02-0001

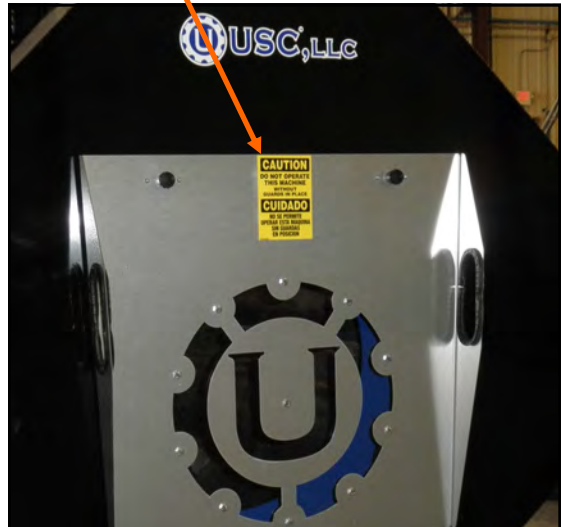
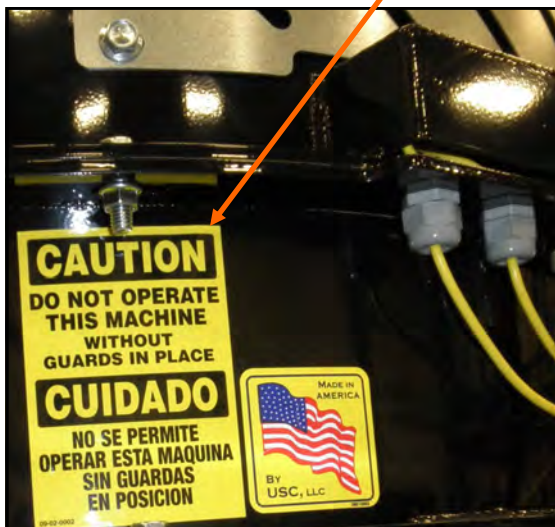

INSTALLATION**SECTION
B**

HIGH VOLTAGE ~ Always disconnect the power source before working on or near the control panel or lead wires.



HAUTE TENSION ~ Toujours débrancher la source d'alimentation avant de travailler sur ou près du panneau de commande ou les câbles.



HIGH VOLTAGE ~ Use insulated tools when making adjustments while the controls are under power.



HAUTE TENSION ~ Utilisez des outils isolés lors des réglages, tandis que les commandes sont sous tension.



Permanent installation may require additional electrical cords, chemical tubing, and air lines, since each installation is unique.



Installation permanente peut exiger cordons électriques, des tubes supplémentaires chimique, et les conduites d'air, puisque chaque installation est.

USC equipment may operate within a Group II, Division 2, Class G hazardous area which contains seed dust. If so, the equipment must be certified for use in this area. To avoid the possibility of an explosion ignited by static electricity, all USC equipment should be grounded by attaching a bonding strip to the metal frame and securing that strip to the factory ground point.

If labeled accordingly, USC products are designed to comply with CSA 22.1 for use in a Class II, Division 2, Group G environment. When connecting the USC system power cord into a power supply, first determine if the supply is also within the hazardous area where the USC system is located. If so, we recommend that the power be hard wired into the source. Do not use a standard electrical plug for this purpose. For other acceptable methods of connecting to a power source, or any other additional miscellaneous equipment to the USC system within a hazardous location, please consult CSA 22.1, Section 18-200 and 18-274. Review the appropriate section and ensure compliance with one of the options given.

When connecting to USC equipment from a remote location, and the USC equipment is in a hazardous Class II, Group G environment, customers are advised to follow the requirements within CSA 22.2 no. 25. More details may also be found in CSA 22.1 18-252 (wiring methods). There are various options covered within this section for wiring in a Class II, Group G (dust) environment. Select the best method suited for your specific location.

LPV SEED TREATER

équipements USC peut fonctionner dans un Groupe II, Division 2, Classe G zone dangereuse qui contient la poussière des semences. Si oui, l'équipement doit être certifié pour une utilisation dans ce domaine. Pour éviter la possibilité d'une explosion enflammé par l'électricité statique, tous les équipements USC doit être mis à la terre en attachant une bande de liaison à la structure métallique et la sécurisation cette bande au point de masse du fabricant.

Si étiquetés en conséquence, les produits USC sont conçus pour être conformes à la norme CSA 22.1 pour une utilisation dans une Classe II, Division 2, Groupe G environnement. Lors du raccordement du USC alimentation du système cordon dans une alimentation, d'abord déterminer si l'offre est également dans la zone dangereuse où se trouve le système USC. Si oui, nous recommandons que le pouvoir soit câblé dans la source. Ne pas utiliser une prise électrique standard à cet effet. Pour les autres méthodes acceptables de se connecter à une source d'alimentation, ou tout autre matériel divers supplémentaire au système USC dans un endroit dangereux, se il vous plaît consulter la norme CSA 22.1, Section 18-200 et 18-274. Consultez la section appropriée et assurer la conformité avec l'une des options proposées.

Lors de la connexion à l'équipement USC depuis un emplacement distant et l'équipement USC est dans une classe dangereuse II, Groupe G environnement, les clients sont invités à suivre les exigences dans CSA 22.2 no. 25. Plus de détails peuvent également être trouvés dans 22,1 CSA 18-252 (Les méthodes de câblage). Il existe diverses options couvertes dans cette section pour le câblage dans une Classe II, Groupe G (poussière) environnement. Sélectionnez la meilleure méthode adaptée pour votre emplacement spécifique.

LPV AUTOMATED TREATER SET - UP

The following steps outline the initial set-up of your USC Seed Treating system:

1. Clear the area of bystanders, especially small children, before moving.
2. Be sure there is enough clearance from overhead obstructions and power lines or other equipment to move the machine into its working position.
3. Using a forklift, place the seed treater in the desired position on a level surface.

NOTICE

USC highly recommends that the seed treater be set up inside a building or any covered structure to protect the machine from weathering.

AVIS

USC recommande fortement que le traitement de semences être mis en place à l'intérieur d'un bâtiment ou d'une structure couverte pour protéger la machine des intempéries.

4. Remove any boxes and cords from the drum of the treater.

LPV AUTOMATED TREATER SET - UP



The LPV Treater **CAN NOT** be lifted using the forklift pockets and or transported without all four of the shipping brackets re-installed. Failure to do so may cause damage to the tilting frame.



Le LPV Traiteur NE PEUT PAS être soulevée à l'aide des passages de fourches et ou transporté sans les quatre supports de transport ré-installé. Ne pas le faire peut causer des dommages au châssis basculant.

5. Install the drum lift actuator kit (03-17-0111) that is shipped separately using steps one through six..

STEP 1: Support the discharge end of the treater drum using the lift ring at the top of the discharge assembly.

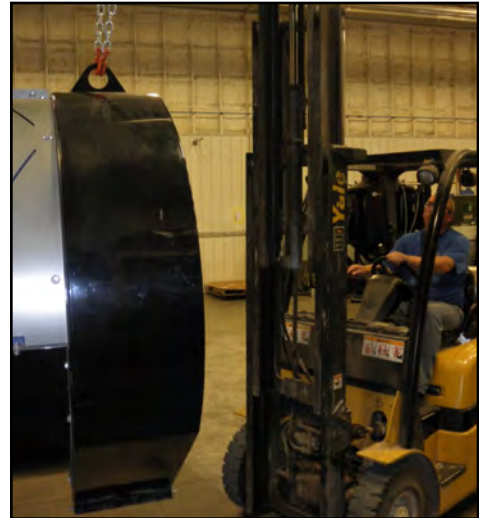

STEP 2: Remove all four of the shipping support brackets



LPV AUTOMATED TREATER SET - UP

STEP 3: Lower the drum slowly until the drum frame is resting on the dead stop pins on both sides of the treater frame.



STEP 4: Insert a clevis pin (06-09-0058) attaching the bottom of the actuator to the bracket on the treater frame cross member.



STEP 5: Insert the second clevis pin (06-09-0058) and the two flat washers (06-05-0005) attaching the end of the actuator piston to the bracket on the drum frame. The washers should be on the outside of the frame bracket.

LPV AUTOMATED TREATER SET - UP

STEP 6: Insert a cotter pin (06-09-0087) in the clevis pins at both ends of the actuator. Then, attach the yellow cable to the motor connector



NOTICE

After the actuator is installed it should move freely by hand. If something is binding, damage to the actuator or the mounting brackets could occur.

AVIS

Après l'actionneur est installé, il doit se déplacer librement à la main. Si quelque chose est obligatoire, les dommages à l'actionneur ou les supports de montage pourrait se produire.

LPV AUTOMATED TREATER SET - UP

6. Anchor the seed treater in position to prevent the machine from moving during operation.
7. Inspect machine thoroughly for screws, bolts, fittings, etc. which may have come loose during shipping.
8. The pump stand(s) should be placed on level ground close to the seed treater.
9. Attach the chemical tubing from the pump stand(s) to the static mixer on the seed treater (below). Additional tubing may be added or removed to accommodate your installation.

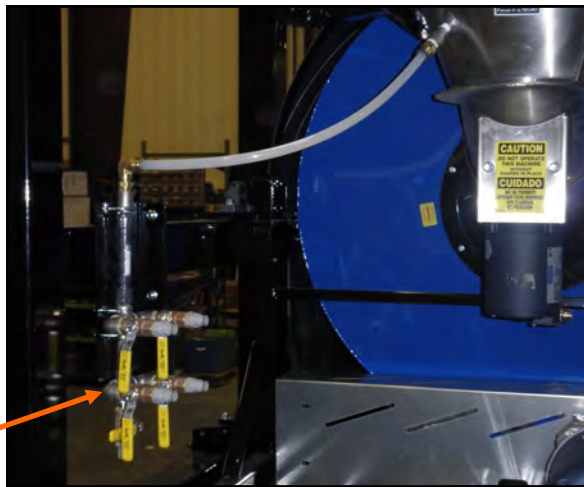

***Static Mixer
Assembly***

10. Setup the Automated Main Control panel at a place that is convenient to the operator. This may include attaching the automated main control panel to the seed treater, to the wall, or to the supplied control panel stand that will require anchoring.
11. Connect the gray cable with light blue ends to one of PJCAN connections on the bottoms of both the main control panel and the treater panel.
12. Connect the red cable to the PJESTOPA on the main control panel and then to the PJESTOPB on the treater control panel. This cable must run from an A connection to a B connection (never A to A or B to B). Connect the other red cable to the PJESTOPA on the treater control panel and then to the PJESTOPB on the I/O control panel. Connect the two red plugs into each of the remaining open PJESTOP connections.
13. Connect the Ethernet cable from the main control panel to the I/O control panel.
14. Connect the cables from Pump Stand(s) to applicable port on the Main Control Panel.

LPV SEED TREATER

MAIN CONTROL PANEL

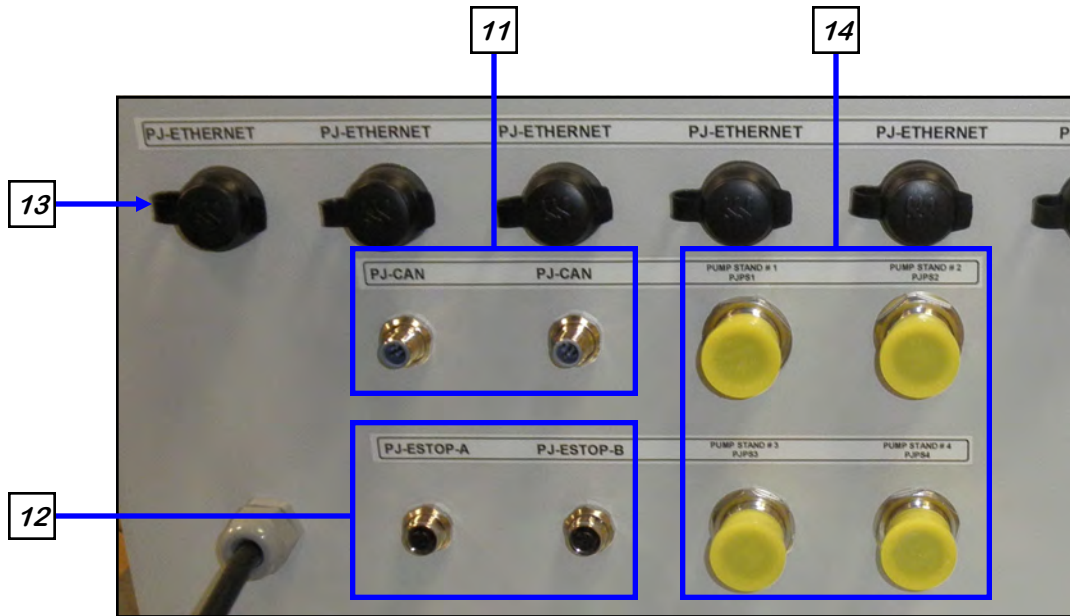

TREATER CONTROL PANEL

- 15. Connect the PJ2101 connector to the 4 pin connector on the Seed Wheel. This connection only exists on LPV Treater with a seed wheel.
- 16. Connect the cable from the drum motor to PJ2006 on the treater control panel.
- 17. Connect the PJ2010 connector from treater panel to the atomizer motor.

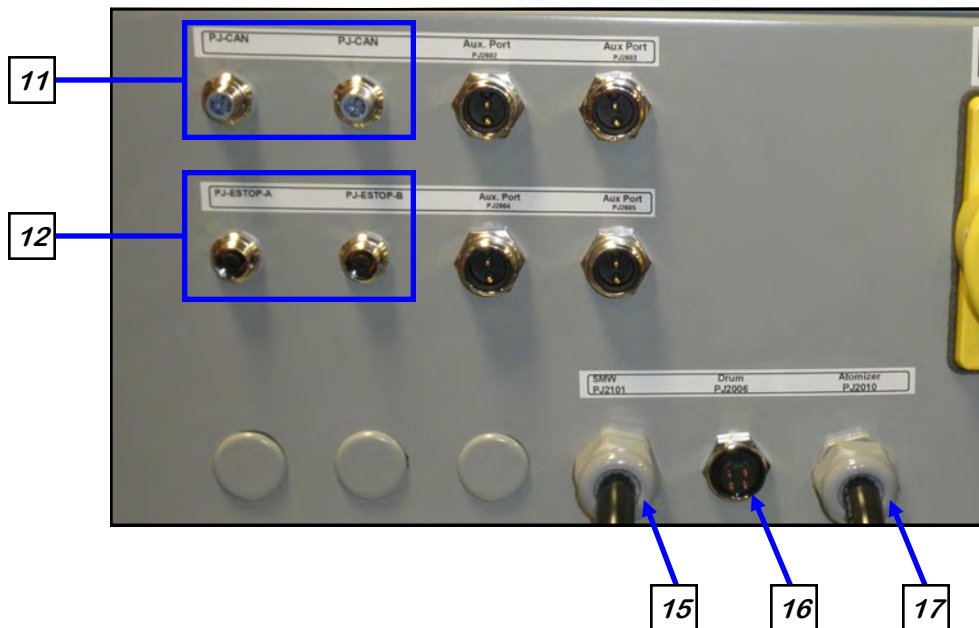

SEED WHEEL I / O CONTROL PANEL

- 18. Connect the cable from PJ1702 to the drum leveling sensor mounted next to the drum motor.
- 19. Connect the cable from PJ1610 to the drum tilt actuator mounted on the lower frame cross member.
- 20. Connect the cable from the proximity sensor mounted in the seed wheel hopper extension to PJ1303.
- 21. Connect the cable from the left side of the seed wheel cable connections to PJ1306.
- 22. Connect the cable from the center of the seed wheel cable connections to PJ1310.

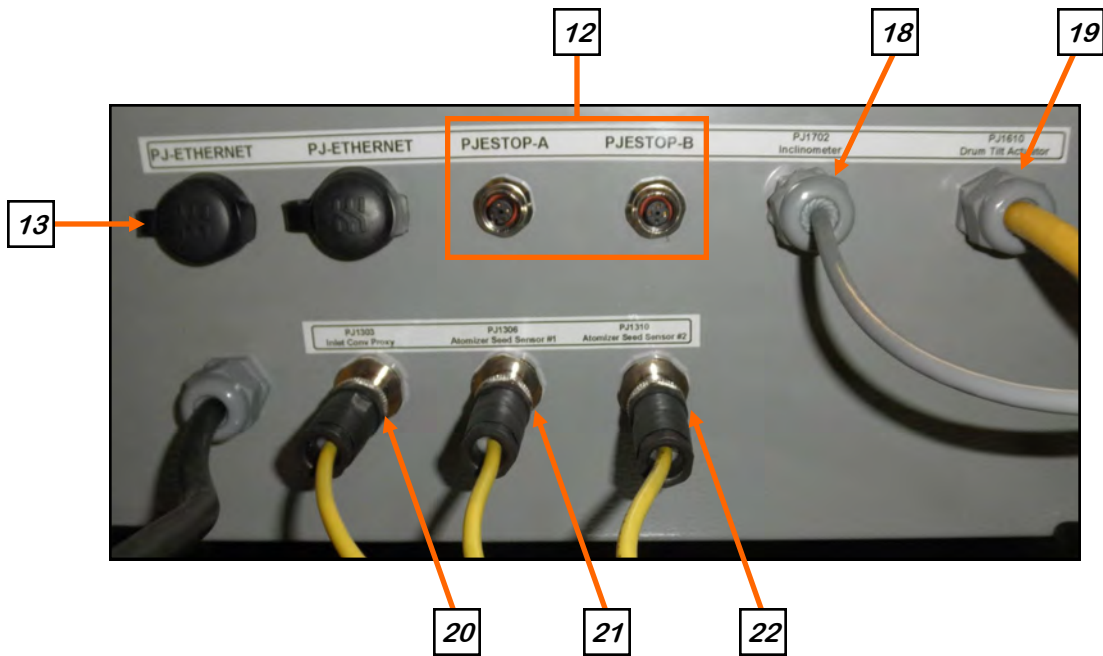

DRUM TILT ACTUATOR

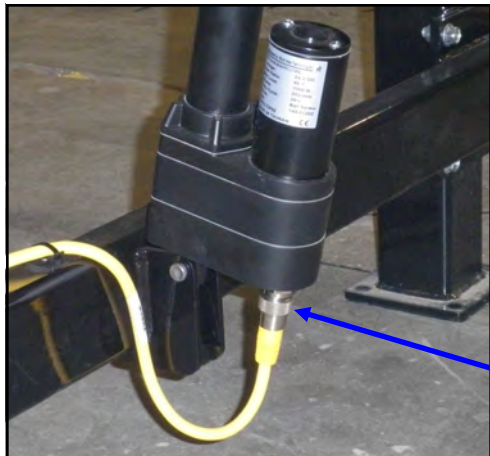

SEED WHEEL

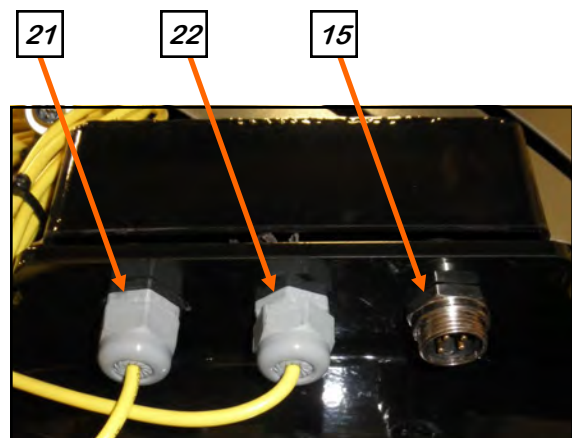

SMW HOPPER PROXIMITEY SENSOR

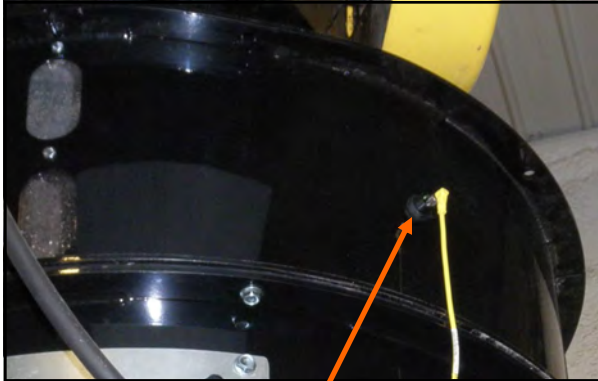

20

DRUM LEVELING SENSOR

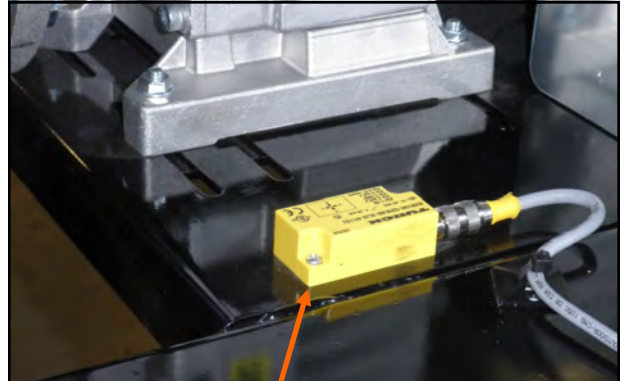

18

LOSS-IN-WEIGHT I / O CONTROL PANEL

- 23. Connect the cable from proximity sensor mounted in the hopper cone to PJ1306.
- 24. Connect the three pin power cable from the Dyadic Actuator to PJ1903.
- 25. Connect the four pin communication cable from the Dyadic Actuator to PJ1909.

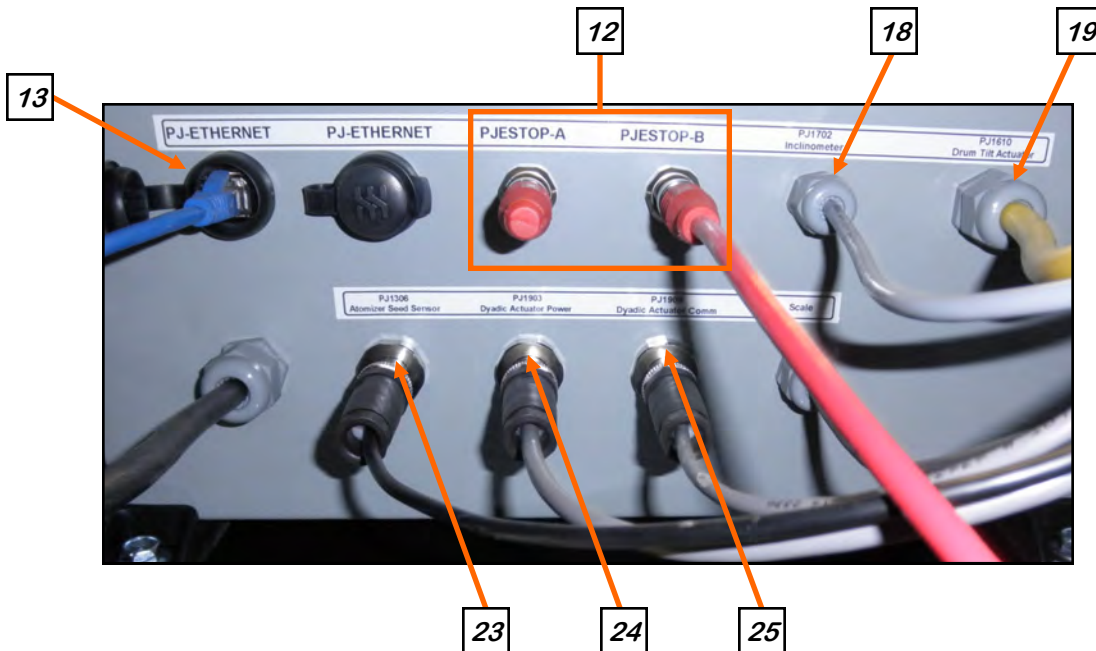

LIW CONE PROXIMITEY SENSOR



23

26. There is a USB port located on the bottom of the panel that can be used to download reports to a compact flash device. The flash device must be in FAT 32 format.

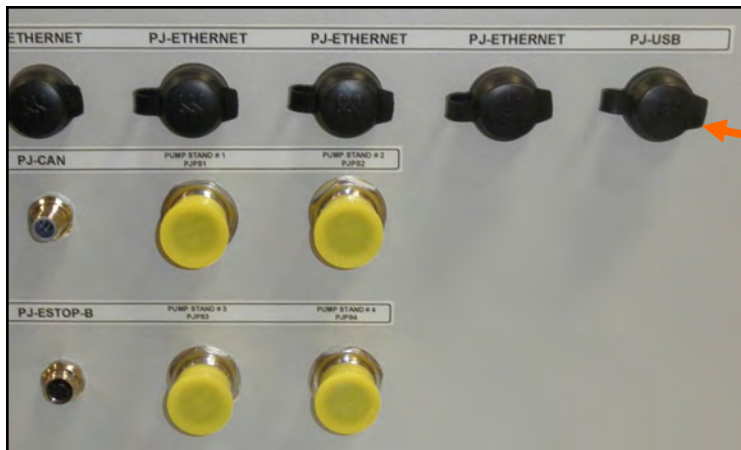

USB Port

27. Connect any conveyors that need to be controlled through the touch screen control panel to the bottom of the treater control panel.



LPV SEED TREATER

28. Two 110V (3 Amp) plugs are located on the left side of the Main Control Panel to allow the operator to plug in a printer to print reports directly from the HMI screen. The second plug can be used to power a laptop computer.



USC™
Seed Treating Solutions

Mfg. By: USC, LLC
Max voltage: 230V, 1PH, 60 HZ
Total FLA: 112
Largest Motor FLA: 40
Schematic number: 13-12-0126A
Enclosure rating: UL type 1
Short Circuit Current Rating:
5ka RMS Sym, 600V Max

WARNING
To maintain over current, short-circuit and ground fault protection, the manufacturer's instruction for selection of overload and short circuit protection must be followed to reduce the risk of fire or electrical shock.

WARNING
If an overload or a fault current interruption occurs, circuits must be checked to determine the cause of the interruption. If a fault condition exists, the current-carrying components should be examined and replaced if damaged, and the integral current sensors must be replaced to reduce the risk of fire or electrical shock.

TREATER CONTROL PANEL
See schematic number: 13-12-0126A for interconnections.

Replacement Fuse Chart				
Fuse	Line	Size	Type	
FU2006	2006, 2008	30A	CLASS CC 600V	
FU2010	2010, 2012	10A	CLASS CC 600V	
FU2101	2101, 2103	10A	CLASS CC 600V	

! WARNING !
230Volts/ 1Phase/60 Hertz supply only.
L1 to Neutral voltage must not exceed 120 Volts!!

USC™
Seed Treating Solutions

Mfg. By: USC, LLC
Max voltage: 115V, 1PH, 60 HZ
Schematic number: 03-12-0366A
Enclosure rating: UL type 1
Total FLA: 3 Amps

Replacement Fuse Chart				
Fuse	Line	Size	Type	
FU1008	1008	4A	SB TL 150VDC CERM	
FU1009	1009	4A	SB TL 150VDC CERM	
FU1209	1209	3A	T SBTD GMD 3-R	
FU1211	1211	1A	T SBTD GMD-1-R	

USC™
Seed Treating Solutions

Mfg. By: USC, LLC
Max voltage: 115V, 1PH, 60 HZ
Total FLA: 6 Amps
Schematic number: 03-12-0382A
Enclosure rating: UL type 1
Short Circuit Current Rating:
5ka RMS Sym, 600V Max

29. Have a certified electrician provide power to the seed treating system. Provide convenient shutdown switches, comply with local electrical codes and ensure that the system is properly grounded and bonded. The USC system must be connected to the same electrical requirements as specified in the main control panel on the power requirement tag, or the electrical schematic shipped with the piece of equipment. This will power the USC LPV seed treater and any attached conveyors.

NOTICE

Flexible conduit is recommended for main power supply.

AVIS

Conduit flexible est recommandé pour l'alimentation principale.

30. Provide 110V single phase power to the main control panel, I/O control panel and the pump stand(s).

31. Reverse the previous steps when removing the machine from its working position.

SECTION C **MECHANICAL OPERATION**

LPV TREATER WITH SEED WHEEL OVERVIEW

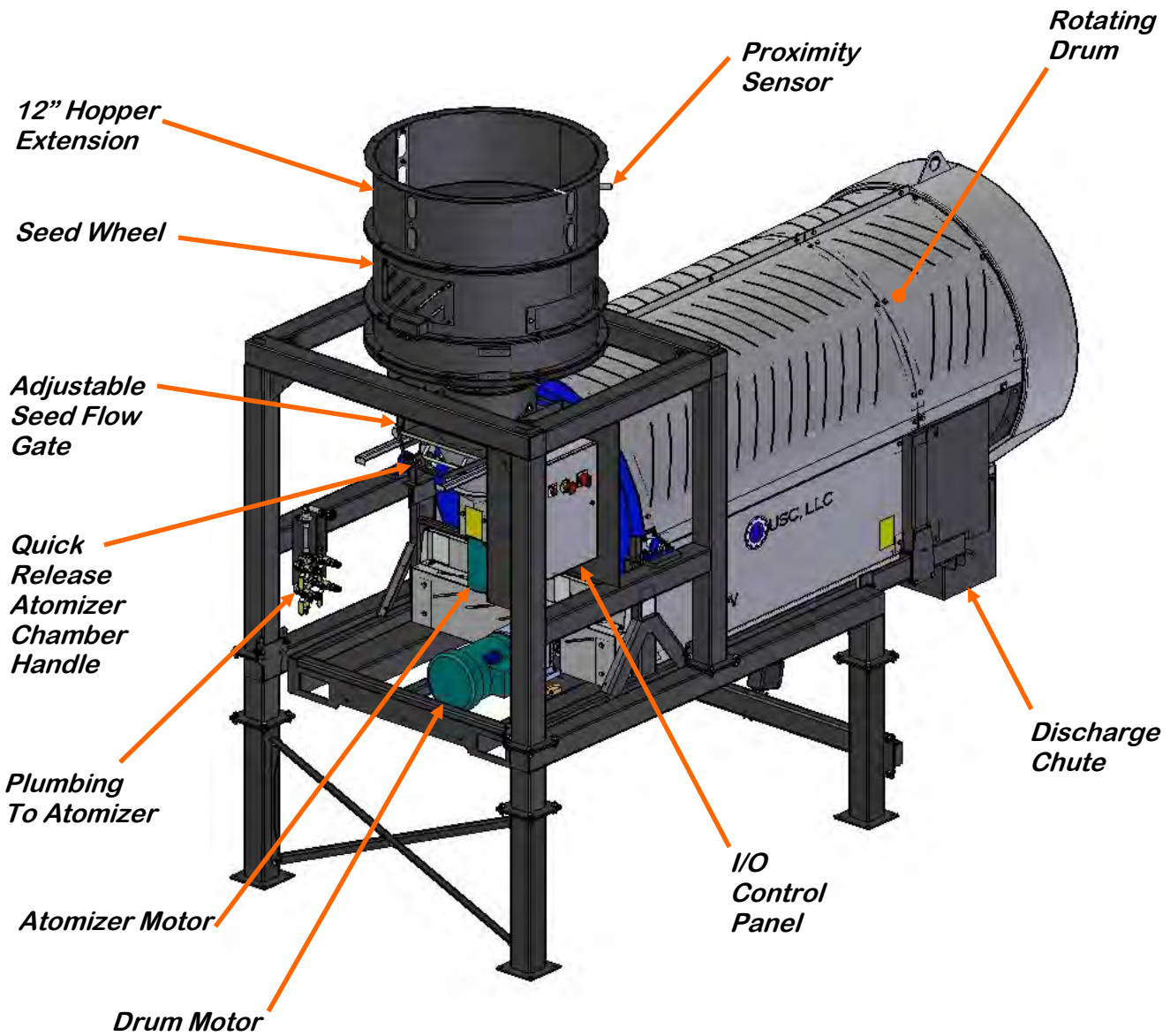

LPV TREATER WITH LOSS-IN-WEIGHT OVERVIEW

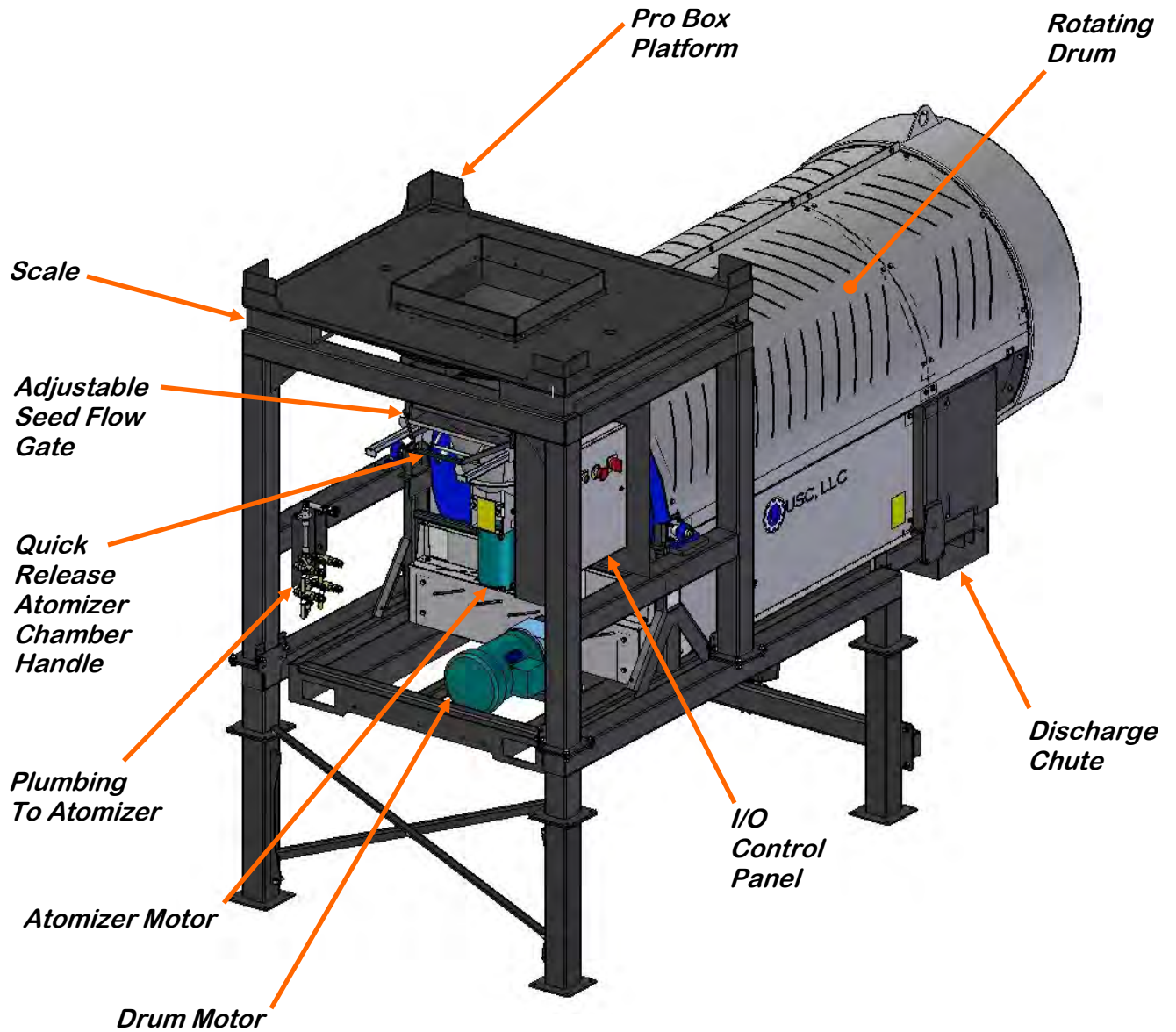

SEED WHEEL

The hopper is equipped with three proximity switches. The top switch controls the inlet conveyor and the lower switches, located in the seed wheel, control the pump(s). Refer to H-O-A Screen in section D. See the Proximity Switch Adjustment Guide in Section F for more in-depth information on these switches.

The Seed Wheel is designed to simplify and increase seed flow calibration accuracy. A rotating wheel is driven by a variable speed motor, which is set prior to treating the seed. This is mounted above the atomizer. The wheel consists of 8 identical pockets approximately 4 inches deep. As it rotates, the wheel captures a certain amount of seed in each pocket. After the seed is caught, the wheel continues rotation and dispenses the seed into the atomizer chamber. With the constant turn of the wheel, there is a consistent amount of seed always sent through the atomizer.

A cup is used to represent a certain percentage of one of the wheels pockets. To calibrate the seed flow, take a sample of the seed to be treated using the cup and weigh it (see page 37). By entering the cup weight of the seed sample the system will automatically adjust the RPM of the Seed Wheel according to the entered target weight.

The purpose of the seed wheel is to simplify calibration and make seed flow calibration more accurate. The seed wheel saves time when switching to different seed sizes and seed types.

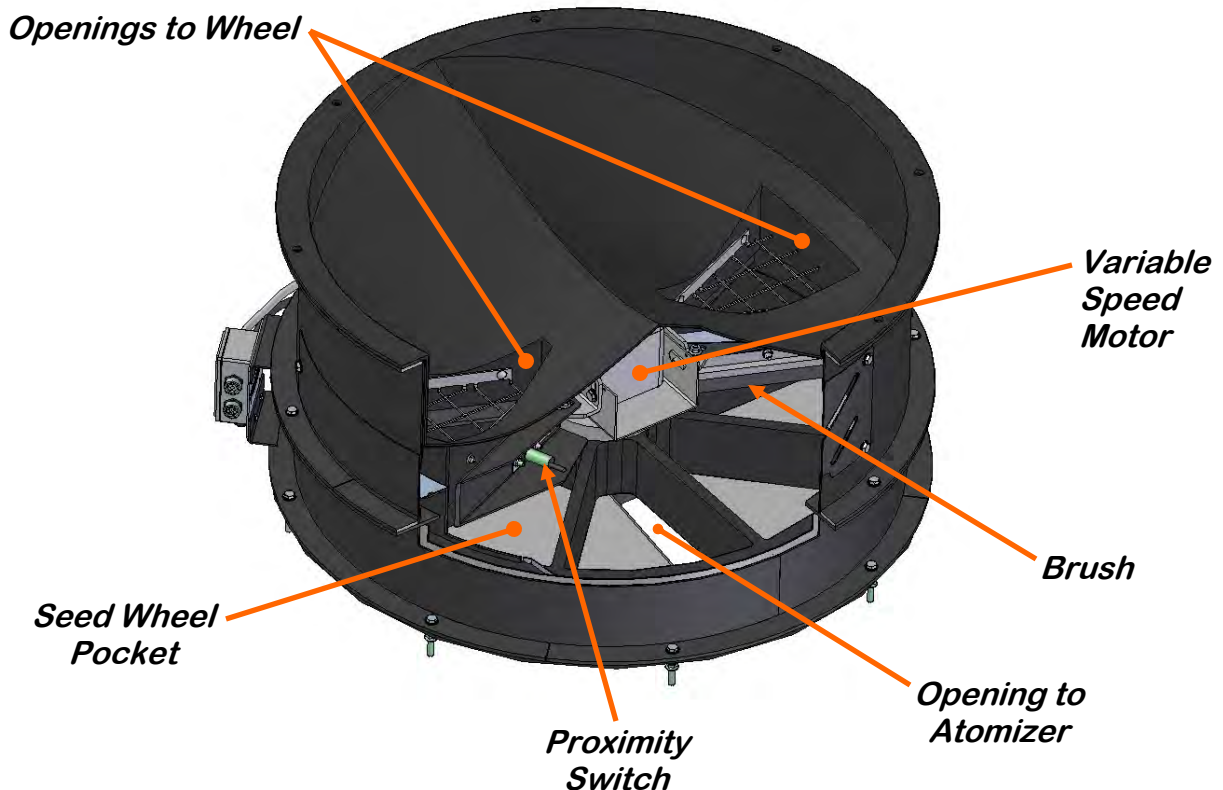

SEED WHEEL ATOMIZER CHAMBER OVERVIEW

The atomizer chamber consists of a patented design which disperses treatment evenly to each seed. A motor drives the atomizer head at approximately 1725 RPM's. As treatment is being pumped into the atomizer chamber, it drops into the atomizer head. The centrifugal force of the spinning head forces the treatment to be sprayed out through a screen covering in all 360 degrees. Meanwhile, seed flows down out of the seed wheel and on top of the distribution cone which disperses the seed down around the atomizer head. The adjustable seed gate is set to fully open and the seed wheel determines the seed flow rate based on the RPM it is running at. The atomizer can be easily accessed for cleaning and maintenance by pulling down on the quick release handle and sliding the atomizer away from the treater body (see page 45).

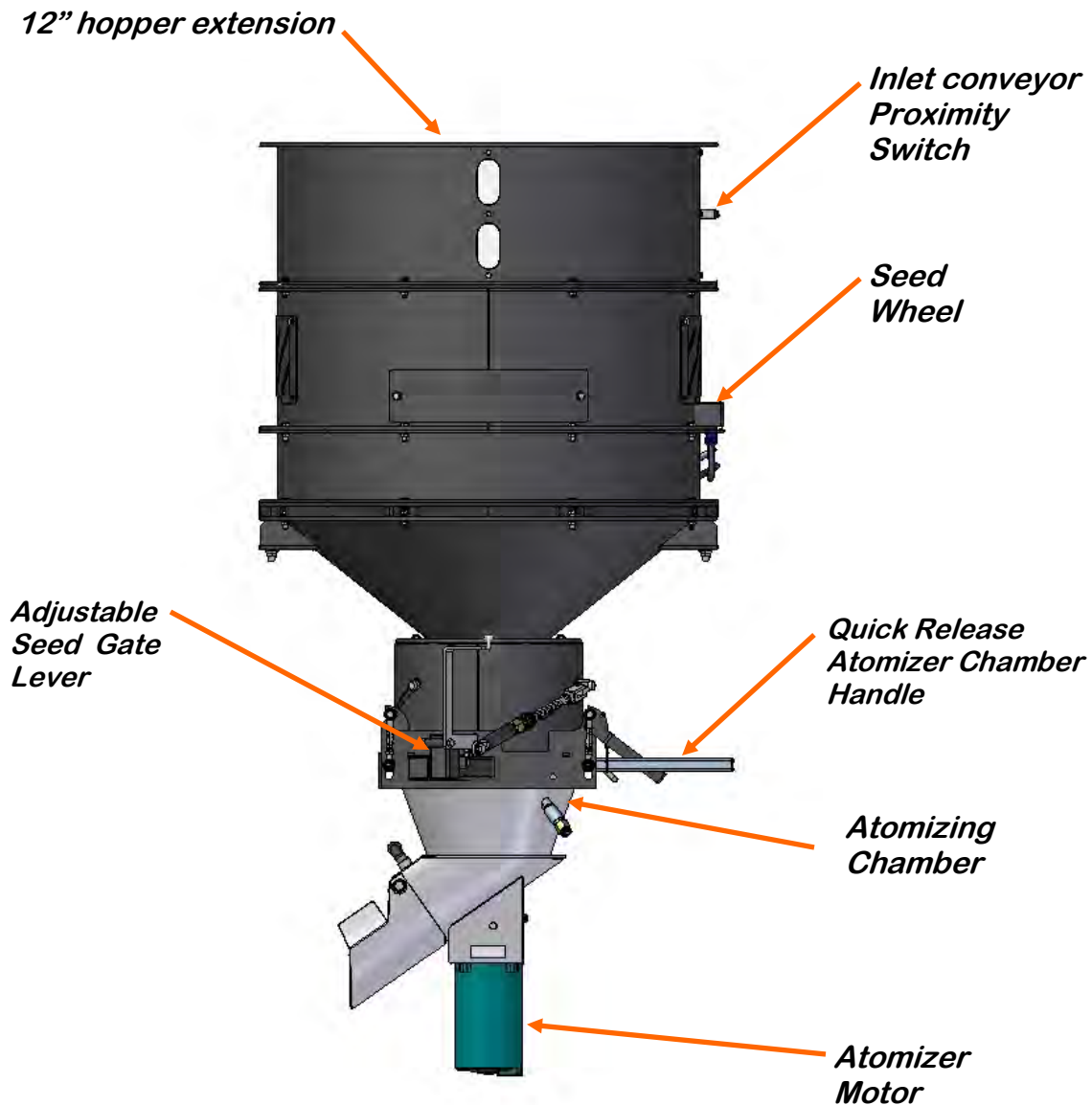

LOSS-IN-WEIGHT ATOMIZER CHAMBER OVERVIEW

The atomizer chamber operates the same way with the Loss In Weight version. The difference is the way that the seed flow is regulated. The adjustable gate on the Loss In Weight version is automatically controlled by an actuator that is constantly adjusting the seed flow gate. The actuator is controlled by the U-Treat automation software to determine the flow rate of the seed flowing down on top of the distribution cone which disperses the seed down around the atomizer head. The atomizer can be easily accessed for cleaning and maintenance by pulling down on the quick release handle and sliding the atomizer away from the treater body (see page 45).

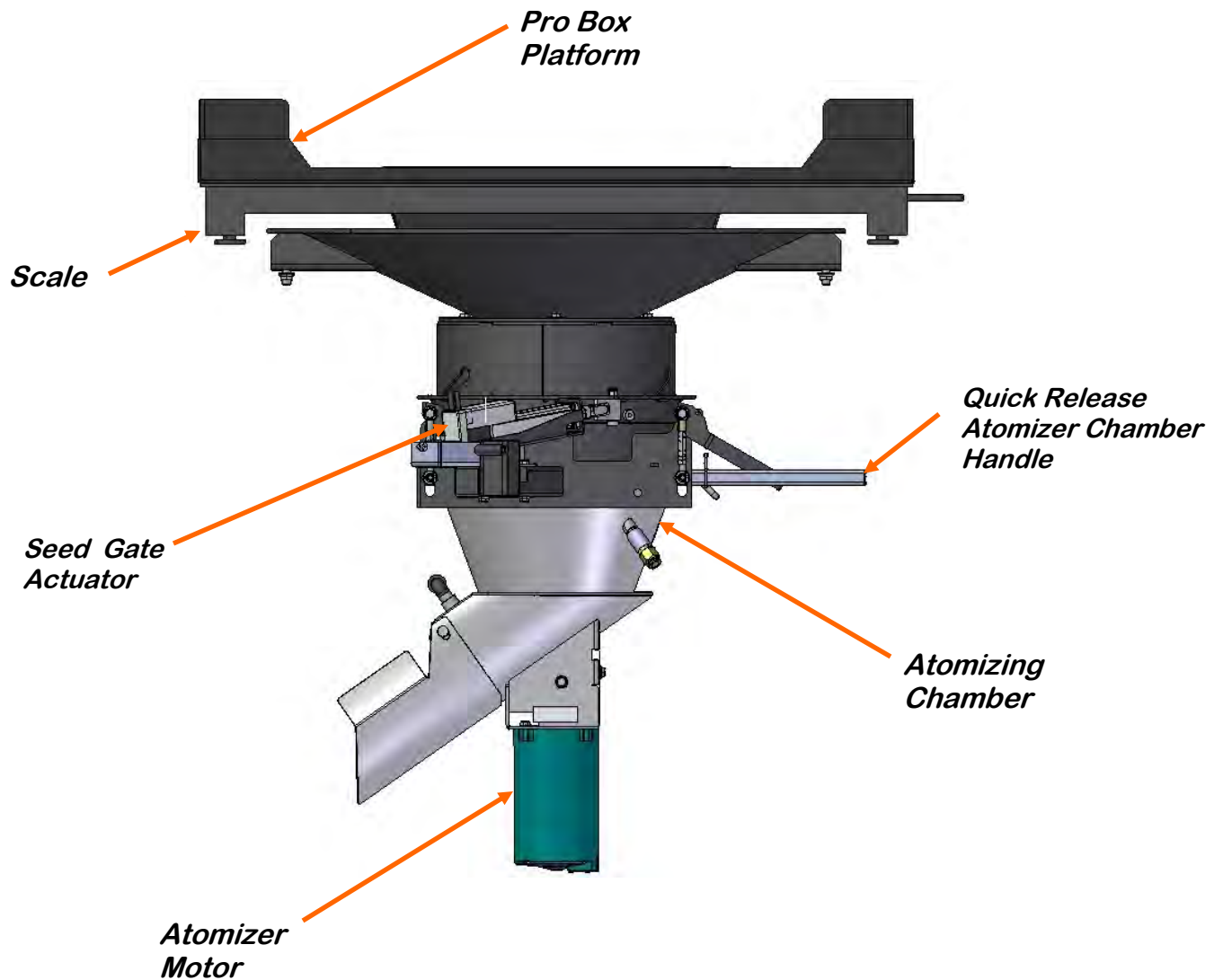

LPV SEED TREATER

The Illustration below shows how seed passes through the atomizing chamber. The red represents treatment being dispensed to the seed as it passes through the chamber. After the seed passes through the atomizer, it goes into the drum where the coating process is completed.

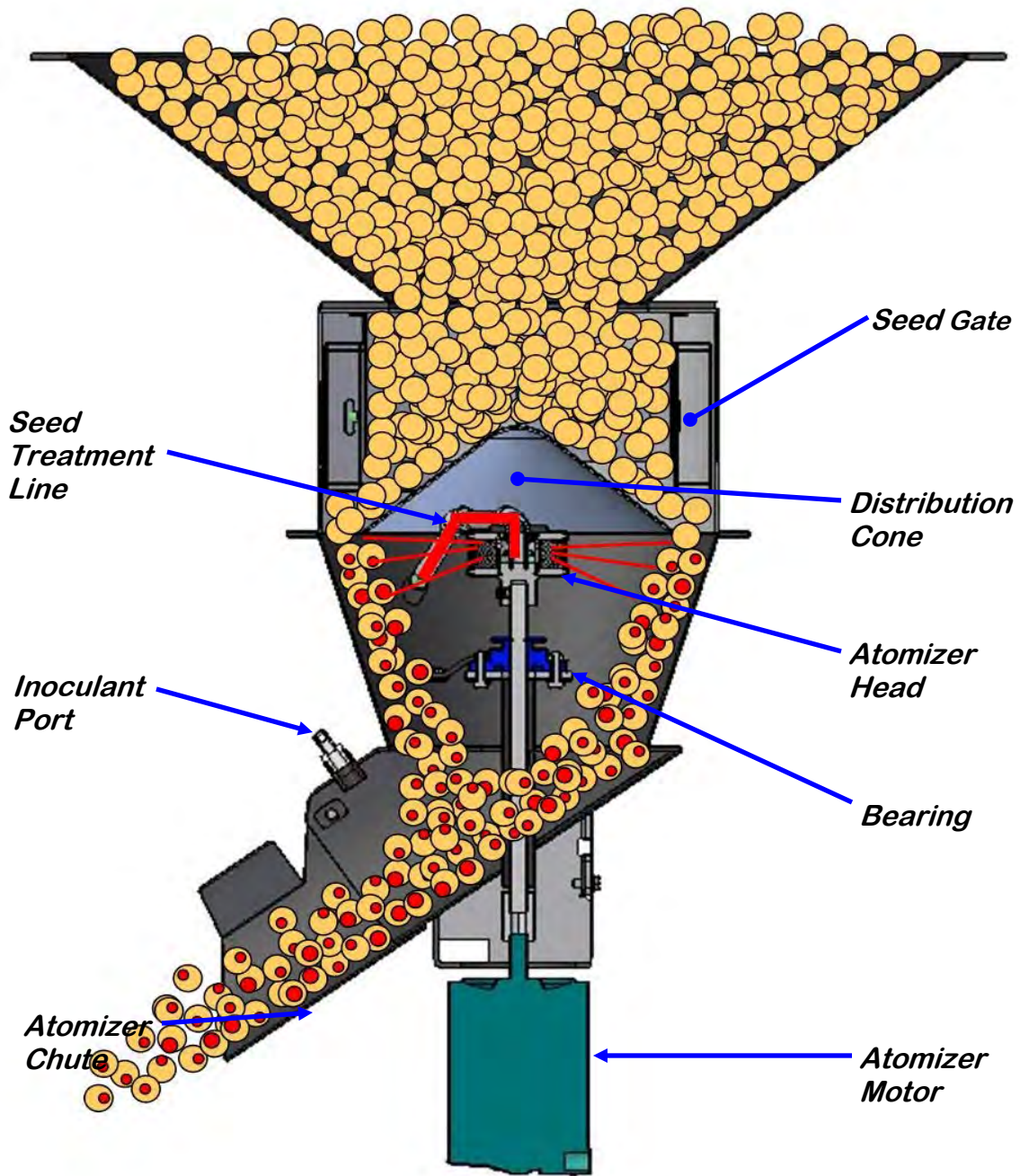

LPV SEED TREATER

ROTATING DRUM

The rotating drum is 8 feet long and accepts treated seed through the opening on the hopper end. As seed passes through the length of the drum it is tumbled, producing accurate and uniform seed coating. The seed then exits the seed treater out the discharge end of the machine.



Never allow exposure of persons or clothing to the drive shaft, idler wheels, or the drum during operation. Always have the safety shields in place during operation.



Ne jamais laisser l'exposition des personnes ou des vêtements à l'arbre d'entraînement, roues libres, ou le tambour pendant le fonctionnement. Toujours avoir les boucliers de sécurité en place pendant le.

The LPV Treater also comes standard with telescoping fork lift pockets. These pockets may be slid out from underneath the treater to allow a fork lift to pick up the treater from it's discharge end.



The rotating drum is grounded to the equipment structure at the factory, to avoid the possibility of generating static electricity, this bonding mechanism should not be tampered with or removed.



Le tambour rotatif est ancré à la structure de l'équipement en usine, afin d'éviter la possibilité de générer de l'électricité statique, ce mécanisme de liaison ne doit pas être altéré ou

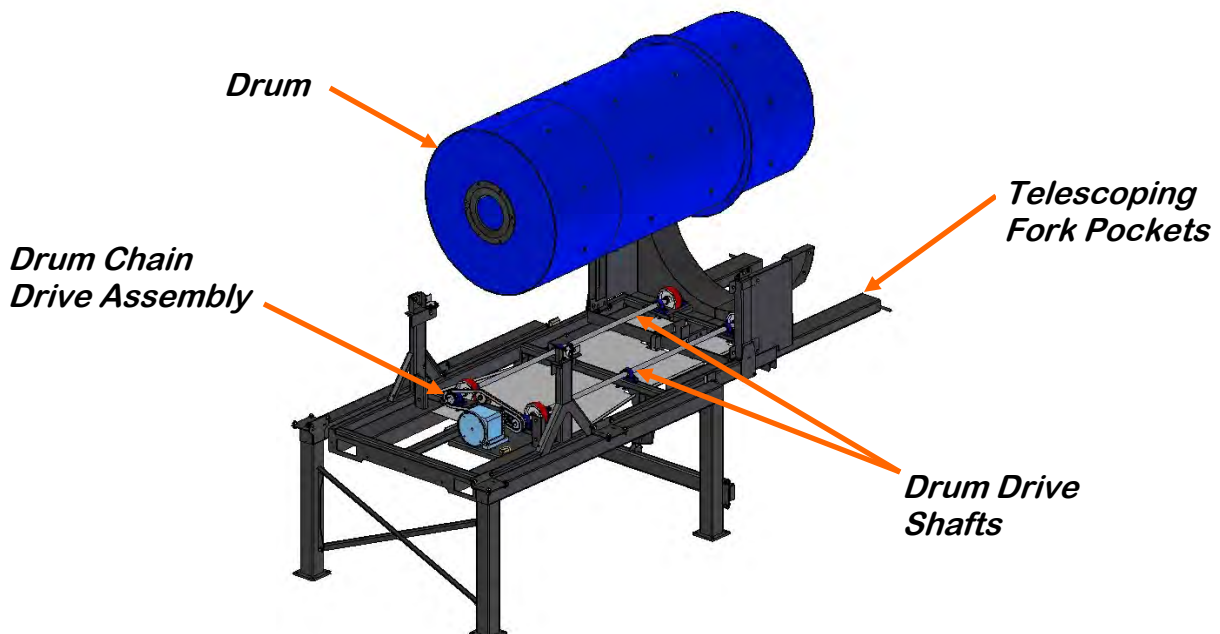

ELECTRICAL OPERATION

SECTION D



HIGH VOLTAGE ~ Always disconnect the power source before working on or near the control panel or lead wires.



HAUTE TENSION ~ Toujours débrancher la source d'alimentation avant de travailler sur ou près du panneau de commande ou les câbles.



HIGH VOLTAGE ~ Use insulated tools when making adjustments while the controls are under power.



HAUTE TENSION ~ Utilisez des outils isolés lors des réglages, tandis que les commandes sont sous tension.



AUTHORIZED PERSONNEL only shall work on the control panel. Never allow anyone who has not read and familiarized themselves with the owner's manual to open or work on the control panels.



Seules personnes autorisées doivent travailler sur le panneau de commande. Ne jamais laisser quelqu'un qui n'a pas lu et se sont familiarisés avec le manuel d'ouvrir ou de travail du propriétaire

For the LPV Automated Treater HMI instructions, see document number:
TD-09-06-1041E = U-Treat v3.6 Automation.

This section provides a general overview and description of the operator control panels for the LPV Seed Treater. If any of the panels are located in the hazardous area described in the installation section (see page 17), all 110VAC connections must be hard wired to a listed type 4 rated enclosure.



USC recommends the use of a surge protection device with a minimum rating of 400 Joules for all automated main control panels.



USC recommande l'utilisation d'un dispositif de protection contre les surtensions avec une cote minimale de 400 joules pour tous les principaux panneaux de contrôle automatisés.

General Panel Descriptions:

- The Automated Main Control Panel is a plug connected enclosure that contains the PLC (Programmable Logic Controller) as well as the HMI (Human Machine Interface) touch screen. The operator is able to control the entire system through the HMI. Power to this panel is supplied by a standard 110V plug.
- The LPV Automated Treater Panel is an enclosure that contains the electrical components required to actuate the seed treater. This includes the VFDs for the atomizer and seed wheel. Power for the treater is supplied here. Power to this panel is hard wired.
- The LPV I/O Control Panel is an enclosure that contains the electrical components required to actuate the drum tilt actuator. This includes the proximity sensors for the seed wheel. Power to this panel is supplied by a standard 110V plug.

CALIBRATION

SECTION E

DETERMINING SEED CUP WEIGHT

The following is a list of steps to use when calibrating the seed wheel. A seed calibration cup, funnel, stand, and scale are used to calibrate the seed wheel.

1. Set the empty seed calibration cup on the scale and zero out the weight of the cup.
2. Place the funnel and stand in the seed to be treated or a separate container (see page 38, figure 1). This will help to avoid any unnecessary clean-up while filling and leveling the top of the seed calibration cup.
3. Place your hand under the bottom of the funnel and fill the funnel up with seed.
4. Place the calibration cup under the funnel stand and remove your hand from the bottom of the funnel, and allow the cup to be filled (see page 38, figure 1).
5. After the cup has been filled, strike off the top of the calibration cup with a straight edge (see page 38, figure 2).

**NOTICE**

Do not shake the cup.

AVIS

Ne secouez pas la tasse.

6. Weigh the sample of seed (see page 38, figure 3).

NOTICE

A typical weight of the sample of seed will be anywhere between 2.8 to 4.0 lbs. Anything over or under this range could be caused by not zeroing out the weight of the cup, or the scale may be set on the wrong units.

AVIS

Un poids typique de l'échantillon de semences sera ne importe où entre 2,8 à 4,0 livres. Tout sur ou sous cette fourchette pourrait être causée par la réduction à zéro ne pas le poids de la tasse, ou la balance peut être réglé sur les mauvaises unités.

DETERMINING SEED CUP WEIGHT

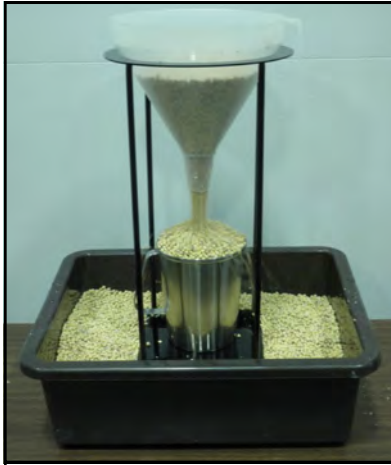

Figure 1



Figure 2



Figure 3

ADJUSTING THE LPV TREATER MANUAL SEED FLOW GATE

The following pictures illustrate how to open, close, and adjust the opening of the seed flow gate.

When the black lever is pulled down, the seed gate is in the CLOSED position, and will not allow seed to flow through.



ADJUSTING THE LPV TREATER MANUAL SEED FLOW GATE

When the black lever is pushed up, the seed gate is in the OPEN position, and seed will flow through.



Regulate the amount of seed flowing through the seed treater by using the spring-loaded coupler and moving it to a different notch. The more notches exposed, the higher the seed flow.



NOTICE

If the seed treater is equipped with a seed wheel, the adjustable seed flow gate should always be left in the most wide open position. If the seed gate is not open fully, seed flow will be diminished and may even cause seed to back up into the seed wheel.

AVIS

Si le traitement de semences est équipé d'une roue de semences, la porte de flux des semences réglable doit toujours être laissée dans la plus grande position ouverte. Si la porte de semences est pas complètement ouvert, écoulement des semences sera diminuée et peut même causer des semences pour sauvegarder dans la roue de semences.

SECTION F TROUBLESHOOTING

Below is a table describing the most frequent mechanical problems and solutions with the USC LPV Seed Treater. For further assistance, contact USC at (785) 431-7900.

Problem	Possible Cause	Solution
Inlet Conveyor will not turn on.	<ol style="list-style-type: none"> 1. Inlet conveyor proximity switch is activated. 2. Inlet conveyor proximity switch is too sensitive. 3. Overload is tripped. 4. Conveyor is plugged into wrong outlet on seed treater panel. 	<ol style="list-style-type: none"> 1. Clean proximity switch 2. Adjust the inlet conveyor proximity switch sensitivity by turning the adjustment screw counter-clockwise (page 42). 3. Reset inlet conveyor overload. 4. Check to make sure the inlet conveyor is plugged into the inlet conveyor receptacle.
Inlet conveyor will not shut off when hopper is full.	<ol style="list-style-type: none"> 1. Seed is not hitting proximity switch. 2. Proximity switch is not set sensitive enough. 3. Inlet conveyor is plugged into wrong receptacle. 4. Hopper proximity switch is not connected 	<ol style="list-style-type: none"> 1. Make sure seed is hitting proximity switch. 2. Adjust the inlet conveyor proximity switch by turning the adjustment screw clockwise (page 42). 3. Make sure inlet conveyor is plugged inlet conveyor receptacle. 4. Connect hopper proximity switch.
Pump will not turn on in AUTO	<ol style="list-style-type: none"> 1. Proximity switch is not staying covered. 2. Atomizer is not on. 3. Proximity switch is not sensitive enough. 4. Pump stand two-wire cord is not plugged into to treater main panel. 5. Both the Chemical Pump switch on the Pump Stand and the Pump/Aux Control on the HMI screen need to be set to AUTO. 	<ol style="list-style-type: none"> 1. Make sure proximity switch is staying covered with seed 2. Turn on atomizer. Atomizer must be on to run the pump in Auto. 3. Adjust pump proximity switch sensitivity by turning the adjustment screw clockwise (page 42). 4. Plug the pump stand two-wire cord into the main treater panel. 5. Set both the Pump Stand switch and Pump/Aux on the HOA screen to AUTO.
Pump is fluctuating.	<ol style="list-style-type: none"> 1. Restriction in tubing 2. Filter is plugged or missing gasket. 	<ol style="list-style-type: none"> 1. Flush tubing and check filter for any restrictions. 2. Clean filter and check for gasket.

LPV SEED TREATER

Problem	Possible Cause	Solution
Pump will not turn off in AUTO when seed runs out.	<ol style="list-style-type: none"> 1. Proximity switch is dirty. 2. Proximity switch is set too sensitive. 	<ol style="list-style-type: none"> 1. Clean proximity switch. 2. Adjust the pump proximity switch sensitivity by turning adjustment screw counter-clockwise (page 42).
Seed calibration is fluctuating.	<ol style="list-style-type: none"> 1. Seed treater supply hopper is not staying full. 2. Restriction in the supply hopper or seed wheel. 3. Build-up in the atomizing chamber. 	<ol style="list-style-type: none"> 1. Make sure the supply hopper and seed wheel are staying full. May have to lower seed flow rate in order to have a consistent flow of seed. 2. Check supply hopper and seed wheel for any debris, and remove. 3. Remove atomizing housing and clean out any build-up of material.
Drum is slipping and seed is coming out the inlet side of the drum.	<ol style="list-style-type: none"> 1. Drum is wet. 2. The seed treater is set too level. 3. Chains are too loose. 	<ol style="list-style-type: none"> 1. Dry off any moisture that may have collected on the outside of the drum. 2. Adjust the slope of the seed treater to at least a 3" drop from front to back. If desired, more slope can be applied. 3. Check and tighten the drive chains. Also check the chain alignment.
None of the motors will turn to ON in HAND mode.	<ol style="list-style-type: none"> 1. Processor is faulted. 2. Emergency Stop button is activated. 3. The Emergency Stop RESET button has not been pressed after the Emergency Stop button has been pulled out. 	<ol style="list-style-type: none"> 1. Disconnect power and wait 30 seconds before reconnecting power. 2. Pull out the Emergency Stop button. 3. After the Emergency Stop button has been pulled out, press the Emergency Stop RESET button.
E-stop is flashing.	<ol style="list-style-type: none"> 1. An E-stop may be depressed. 2. Power may not be on to the control panels. 3. One of the control panels may not be connected to all of the others. 	<ol style="list-style-type: none"> 1. Ensure all E-stops are not depressed. 2. Check incoming power to each control panel. 3. Check the wiring and connections to each control panel.

PROXIMITY SWITCH ADJUSTMENT GUIDE

The proximity switches mounted in the extension ring and the seed wheel detect when seed is present.

The proximity switch located in the extension ring is used to automatically shut off the inlet conveyor when the surge hopper is full. This proximity switch is not present on tower systems.

The proximity switches located in the seed wheel automatically shut off the pump when all seed has left the hopper.

If the proximity switch is not working properly, this can be caused by wear, dust, or even moisture. The first step is to clean the lens of the proximity switch. If this does not solve the problem, the next step would be to adjust the sensitivity of the proximity switch.

The green light indicates the power status. If it is active the device is powered.

The amber light indicates when seed is being detected. If it is active it detects seed, if inactive it does not detect seed.

Using the small screwdriver provided inside the control panel, you can adjust the proximity switch by turning the adjusting screw on the back of the proximity switch.

- Turn Clockwise to make the proximity switch more sensitive.
- Turn Counterclockwise to make the proximity switch less sensitive.

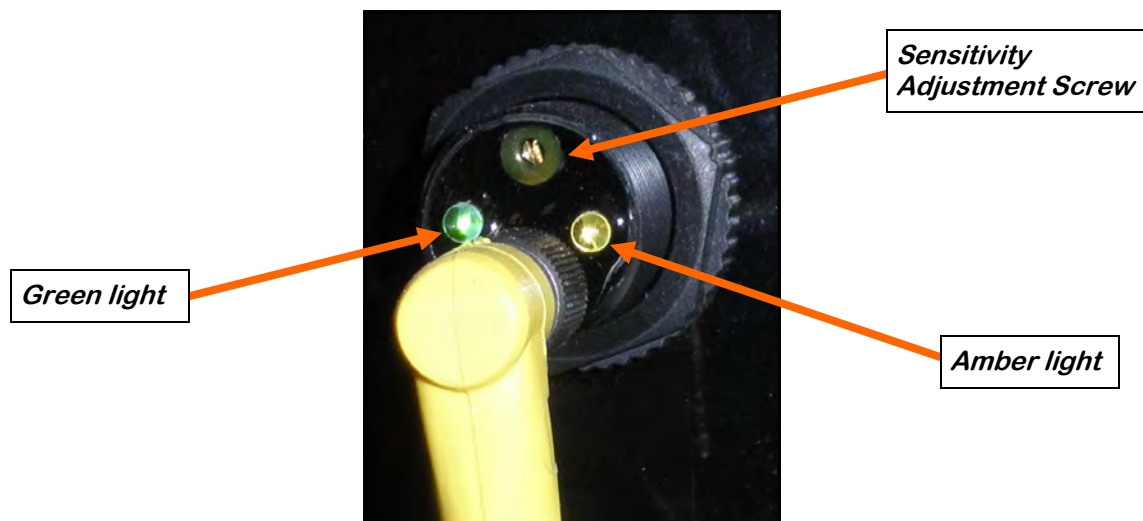

Proximity Switch Screwdriver

MAINTENANCE

SECTION G

Proper maintenance of the LPV Seed Treater is critical for peak performance, reliability and accuracy of this system. The following is a guideline for the type of maintenance and servicing that should be performed on this unit. Your environment and uses may require additional maintenance and service beyond this list to assure a reliable and safe unit. The operator of this unit has ultimate responsibility to identify areas of concern and rectify them before they become a hazard or safety issue. There is no substitute for a trained, alert operator.



Do not put this unit into operation with any questionably maintained parts. Poor performance or a hazard may occur.



Ne pas mettre cet appareil en service avec des pièces douteuse entretenus. La mauvaise performance ou un danger peut survenir.



Do not use compressed air or water under pressure to clean any of the components of the USC equipment.



Ne pas utiliser d'air comprimé ou de l'eau sous pression pour nettoyer l'un des composants de l'équipement USC.

GREASING

Use an SAE multipurpose high temperature grease with extreme pressure (EP) performance. Also acceptable is an SAE multipurpose lithium-based grease.

- Use a Maintenance Checklist to keep record of all scheduled maintenance.
- Use a hand-held grease gun for all greasing.
- Wipe grease fitting with a clean cloth before greasing to avoid injecting dirt and grit.
- Replace and repair broken fittings immediately.



If fittings will not take grease, remove and clean thoroughly. Also clean lubricant passageway. Replace fitting if necessary.



Si les raccords ne prendront pas la graisse, enlever et nettoyer. Aussi propre passage de lubrifiant. Remplacer approprié si nécessaire .

SEED WHEEL

- Inspect all welds and structural components for bends, cracks and damage.
 - Remove the front and rear shields with the vent slots to inspect wheel, brushes and proximity switches.
 - Use a vacuum to clean out any seeds and excess build-up that may have occurred during operation. Wipe down the motor casing with a damp cloth making sure to remove all dust that may have collected since the last maintenance date. Record the cleaning on the company required documents. If operating in a CSA 22.1, Class II, Division 2, Group G hazardous area, USC recommends this step be performed on a daily basis.
 - Utilisez un aspirateur pour nettoyer les graines ou accumulation excès qui ont pu se produire pendant le fonctionnement. Essuyez le carter moteur avec un chiffon humide en veillant à éliminer toutes les poussières qui peuvent avoir perçu depuis la dernière date de maintenance. Enregistrez le nettoyage sur la société les documents requis. Si opérant dans un CSA 22.1, Classe II, Division 2, Groupe G zone dangereuse, USC recommande cette étape être effectuée sur une base quotidienne .
-

DRIVE AND DRUM

- Remove drum guards and inspect all welds and structural components on the frame and drum for bends, cracks and damage.
- Inspect pillow block bearings and grease every 40 hours of operation.
- Inspect drive wheels for unordinary wear and set screws for tightness.
- Inspect the Neoprene idler wheels for unordinary wear and adjust if necessary.
- Remove drive guards, tighten and lubricate chain every 40 hours of operation.
- Wipe down the motor casing with a damp cloth making sure to remove all dust that may have collected since the last maintenance date. Record the cleaning on the company required documents. If operating in a CSA 22.1, Class II, Division 2, Group G hazardous area, USC recommends this step be performed on a daily basis.
- Essuyez le carter moteur avec un chiffon humide en veillant à éliminer toutes les poussières qui peuvent avoir perçu depuis la dernière date de maintenance. Enregistrez le nettoyage sur la société les documents requis. Si opérant dans un CSA 22.1, Classe II, Division 2, Groupe G zone dangereuse, USC recommande cette étape être effectuée sur une base quotidienne.

ATOMIZER

To access the inside of the atomizer housing, disconnect the motor power cable from the atomizer motor, push up on the quick release handle and slide out the atomizer. After completing maintenance, slide the atomizer back into the operating position, pull down quick release handle to lock it in place and reconnect the motor power cord.

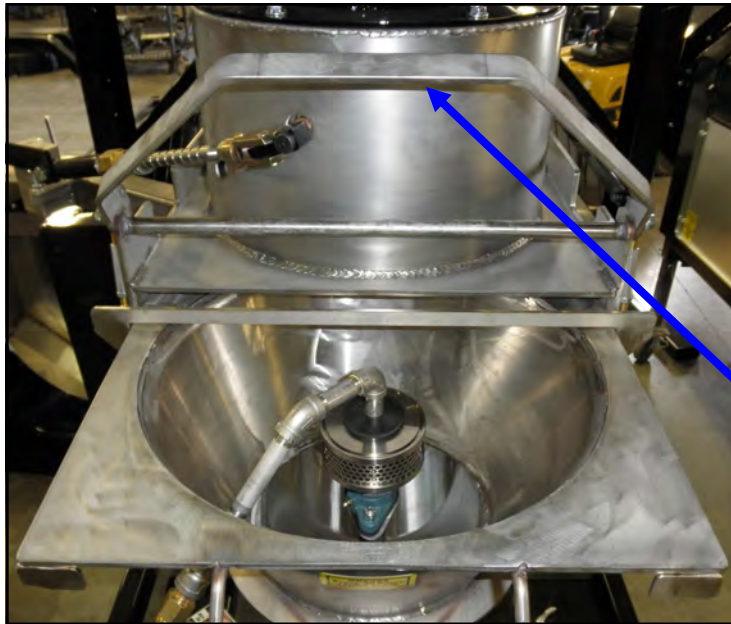

Quick-Release Handle

Atomizer Head

1. Slide out atomizer housing and grease bearing inside. Bearing needs just one pump of grease every 40 hours of operation (right).
2. Clean any build up inside the housing and the atomizer head. To remove the atomizer head, loosen the set screw located on the bottom of the head.
3. Check for any play in the atomizer shaft.
4. Make sure the atomizer spins smoothly.
5. Ensure the adjustable chute is fitting completely into the drum opening. Adjust if necessary.

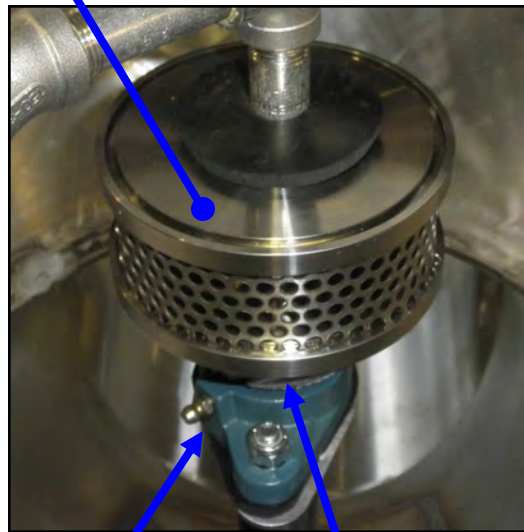

Bearing

Set Screw

ATOMIZER MOTOR

- Wipe down the motor casing with a damp cloth making sure to remove all dust that may have collected since the last maintenance date. Record the cleaning on the company required documents. If operating in a CSA 22.1, Class II, Division 2, Group G hazardous area, USC recommends this step be performed on a daily basis.
- Essuyez le carter moteur avec un chiffon humide en veillant à éliminer toutes les poussières qui peuvent avoir perçu depuis la dernière date de maintenance. Enregistrez le nettoyage sur la société les documents requis. Si opérant dans un CSA 22.1, Classe II, Division 2, Groupe G zone dangereuse, USC recommande cette étape être effectuée sur une base quotidienne.

PUMPS AND PLUMBING

- Check pump in forward and reverse.
- Make sure pump heads open and close smoothly.
- Inspect tubing and for uneven wear. Replace pump tubing often to ensure high flow rates can be met.
- Tighten hose clamps and check filter. Clean filter frequently to avoid blockages
- Flush flow meter with clean water frequently to avoid chemical buildup.
- Wipe down the motor casing with a damp cloth making sure to remove all dust that may have collected since the last maintenance date. Record the cleaning on the company required documents. If operating in a CSA 22.1, Class II, Division 2, Group G hazardous area, USC recommends this step be performed on a daily basis.
- Essuyez le carter moteur avec un chiffon humide en veillant à éliminer toutes les poussières qui peuvent avoir perçu depuis la dernière date de maintenance. Enregistrez le nettoyage sur la société les documents requis. Si opérant dans un CSA 22.1, Classe II, Division 2, Groupe G zone dangereuse, USC recommande cette étape être effectuée sur une base quotidienne.

MIX TANK

- Check motor.
 - Check motor for any play in the mix tank shaft.
 - Check valves, fittings, and plug on bottom of tank for leaks.
 - Check chemical line tubing for abnormal wear.
 - Wipe down the motor casing with a damp cloth making sure to remove all dust that may have collected since the last maintenance date. Record the cleaning on the company required documents. If operating in a CSA 22.1, Class II, Division 2, Group G hazardous area, USC recommends this step be performed on a daily basis.
 - Essuyez le carter moteur avec un chiffon humide en veillant à éliminer toutes les poussières qui peuvent avoir perçu depuis la dernière date de maintenance. Enregistrez le nettoyage sur la société les documents requis. Si opérant dans un CSA 22.1, Classe II, Division 2, Groupe G zone dangereuse, USC recommande cette étape être effectuée sur une base quotidienne.
-

ELECTRICAL PANEL

- Check and tighten wire connections.
- Check quick connects on bottom of control panel.
- Check to see if starters and/or overloads are tripped.
- Check to see if relays, timers and/or breakers are tripped.
- Check and set the proximity switches. (page 42).
- Check quick connects on end of Auxiliary cord.
- Check relay and fuse holder.
- Check power cords for cuts or frays and ensure ground is present.

SECTION H STORAGE

When storing the LPV Seed Treater for long periods of time, the following procedure must be followed to reduce the chance of rust, corrosion and fatigue of the treater. You can also use these steps when storing the machine for the winter.



A dust mask and protective rubber gloves shall be used when cleaning the machine.

SEEDWHEEL & SUPPLY HOPPER

1. Turn power off to the treater and treater components.
2. Remove shields from the seed wheel and remove any debris or build-up. Compressed air can be used to blow out any foreign material.
3. Turn power back on to the treater and run seed wheel to help remove any additional debris. Compressed air can be used to blow out any foreign material.
4. Check brushes for wear (below).
5. Wipe off and clean the lens of the proximity switches (below).
6. Disconnect power and mount all guard back in place.
7. Tarp or cover the supply hopper and seed wheel to keep out any dirt or unwanted pests.

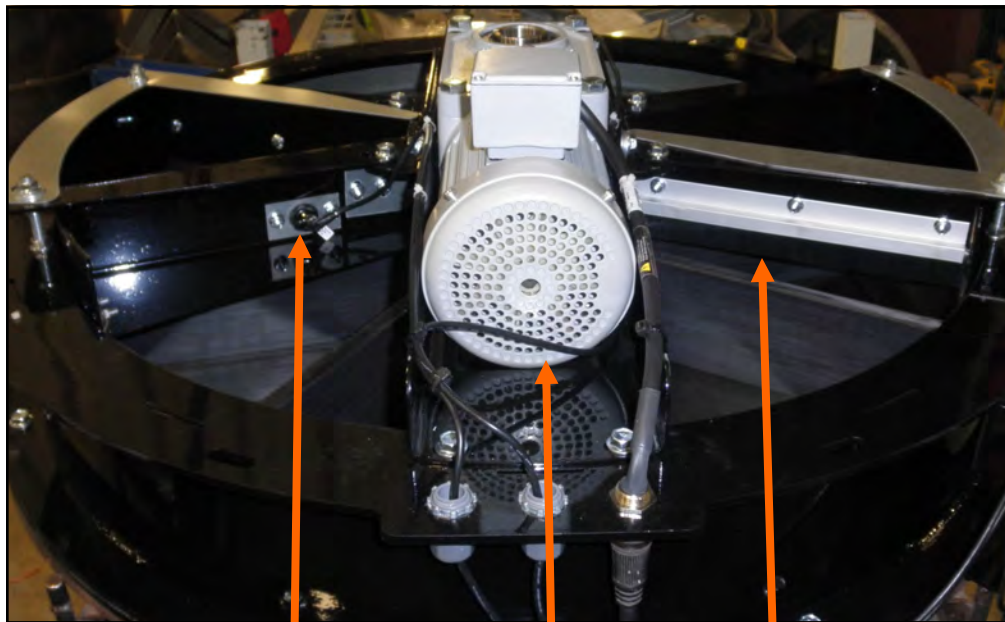

Proximity Switch

Motor

Brush

ATOMIZER CHAMBER

1. Remove and clean the atomizer housing.
2. Remove the atomizer head and stainless steel plumbing. The atomizer head may be disassembled (right), for easier cleaning. It is threaded together and can simply be unscrewed.
3. Reinstall the atomizer head and plumbing. Grease the bearing and spin the atomizer head a few times to ensure all grease has been worked into the bearings.



ROTATING DRUM

1. Remove the shields and clean out any seed that may have fallen underneath the drum.
2. Clean out any residue left on the inside of the drum and around the seed lifters.
3. Lubricate the chain to keep from corroding in storage.

FINAL

1. Disconnect power to the machine.
2. Store the machine inside a protective building to keep it from being exposed to the weather.
3. Ensure all guards and safety labels are in place.

LPV SEED TREATER

NOTES:

MECHANICAL DRAWINGS

SECTION I

The following pages show the parts of the LPV Seed Treater. Please have the part number ready when ordering parts.

DISCHARGE CHUTE ASSEMBLY(18-01-0072)

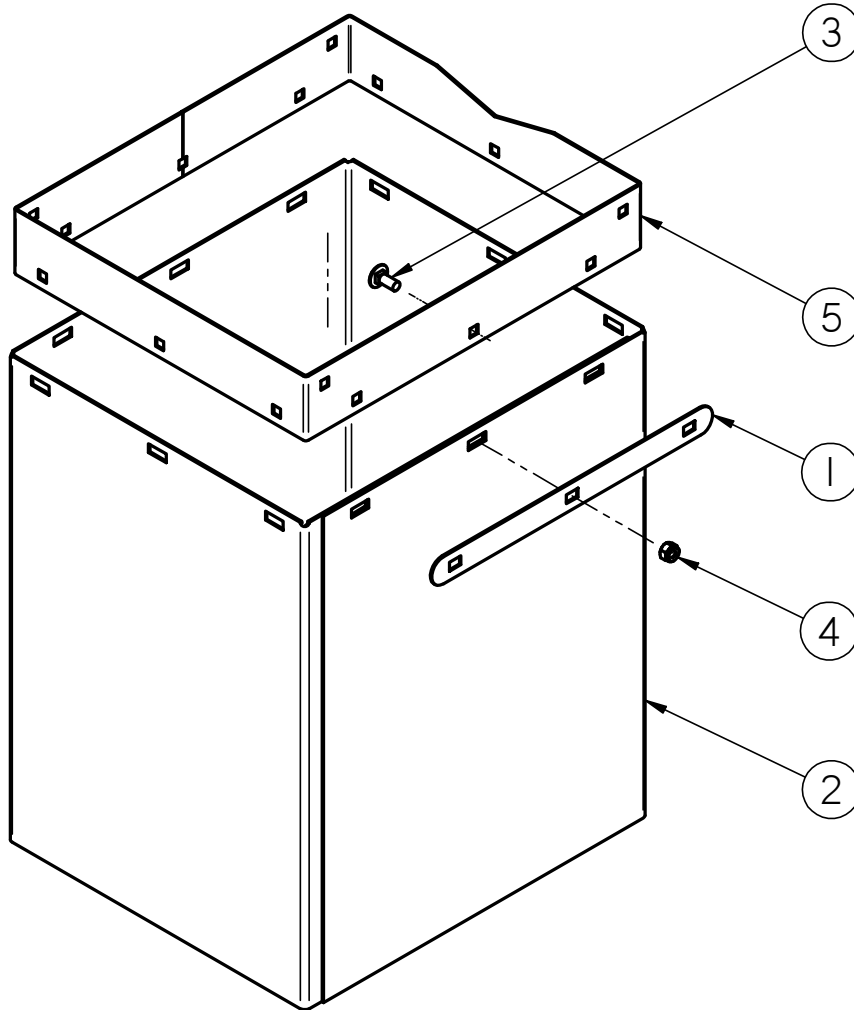

Item #	Part #	Description	Qty
1	05-10-3400	PLT DSCHG TRTR	4
2	05-10-3886	SKIRT DSCHG TRTR LPV2000	1
3	06-01-0171	BOLT CRG .3125-18X.750 ZP SHORT NECK	12
4	06-03-0002	NUT NYL LOCK .313-18 ZP GR5	12
5	101FB5	ADPT END CHUTE EXT LPV2000	1

LPV SEED TREATER

END CHUTE DOOR ASSEMBLY (05-07-0198)

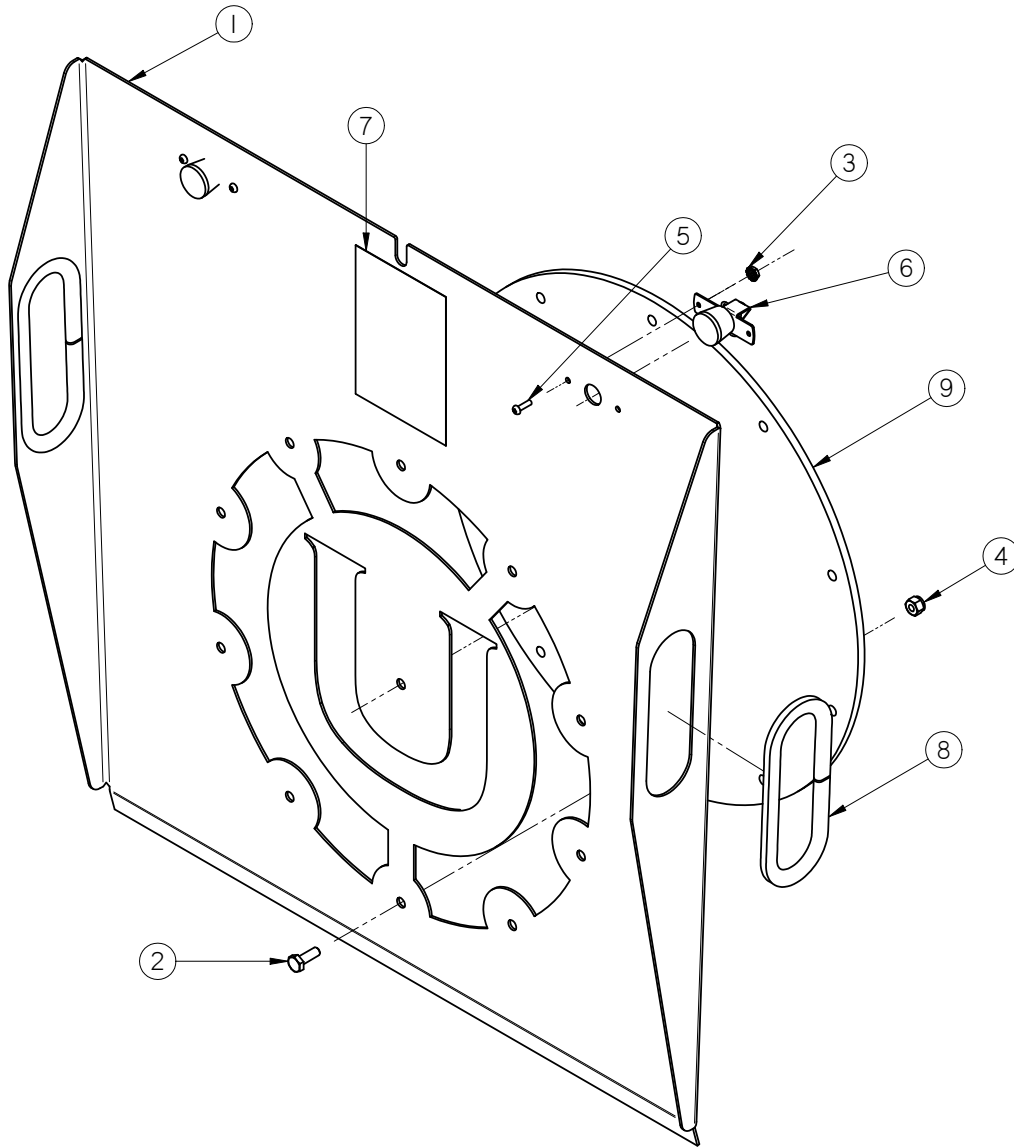

Item #	Part #	Description	Qty
1	05-10-3919	PLT DSCHG CHUTE DOOR GALV W LOGO	1
2	06-01-0006	BOLT, .250-20 X .75 UNC ZP GRADE 5	11
3	06-02-0033	NUT 6-32 K-LOCK ZP	4
4	06-03-0001	NUT,LOCK, .250-20 ZP G5 NYLON INSERT	11
5	06-06-0032	SCRW MACH 6-32 X .500 PHLP RDHD ZP	4
6	06-09-0028	LATCH SPRING SOUTHCO 57-10-401-10	2
7	09-02-0002	ATWK LBL DANGER GUARDS	1
8	1008C4	EDGING	2
9	102098	COVER	1

LPV SEED TREATER
END CHUTE ASSEMBLY (18-01-0270)

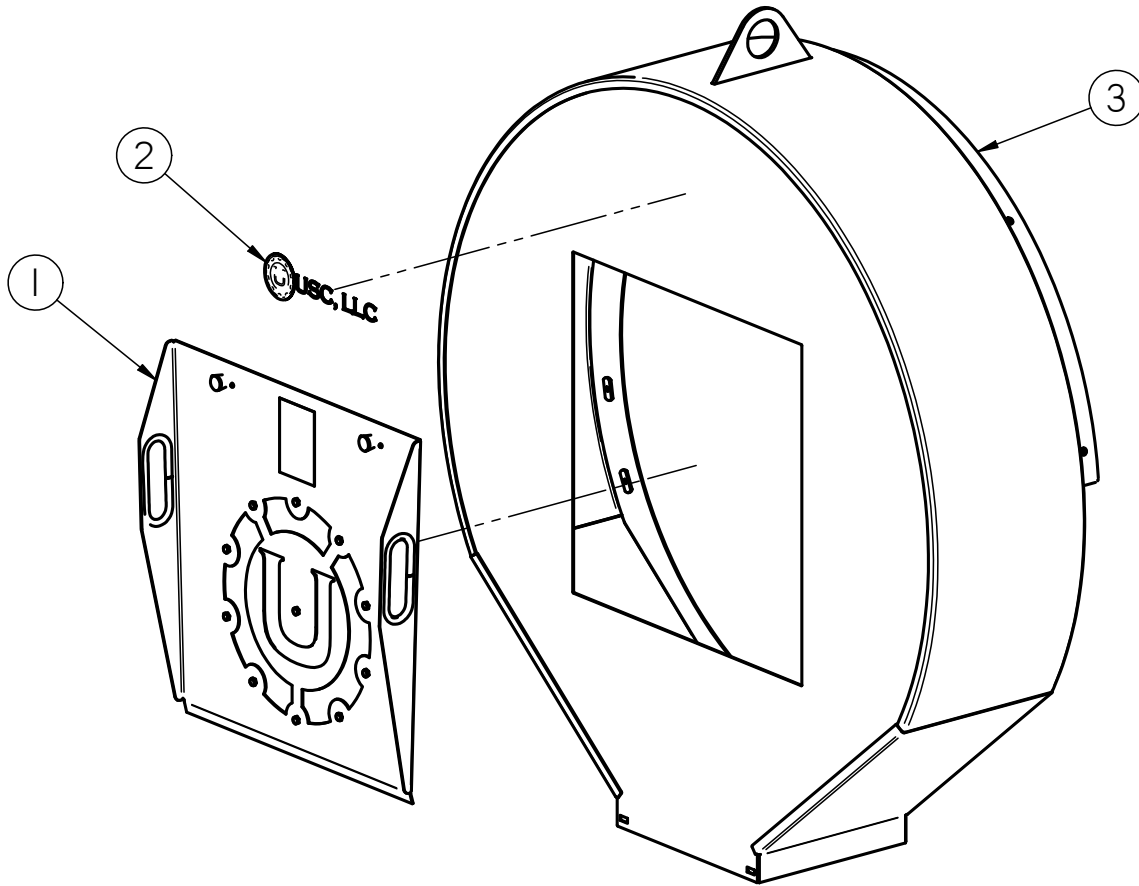

Item #	Part #	Description	Qty
1	05-07-0198	ASSY END CHUTE DOOR GALV	1
2	09-01-0042	ATWL LBL USC, LLC 3" X 15" PRO-CUT	1
3	18-01-0268	WDMT END CHUTE	1

LPV SEED TREATER
LPX STATIC MIXER (04-03-0255)

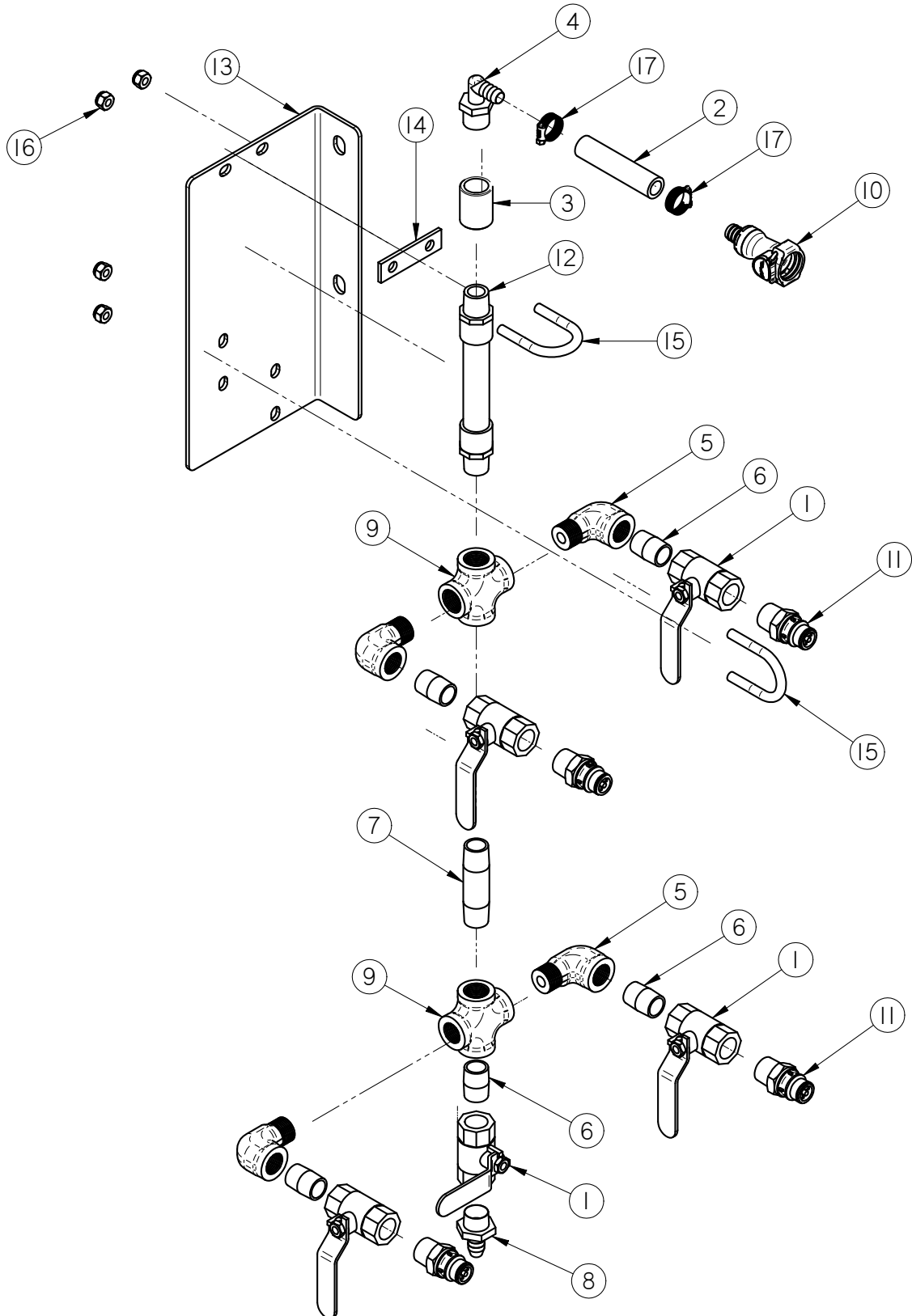

LPV SEED TREATER

LPX STATIC MIXER (04-03-0255)

Item #	Part #	Description	Qty
1	02-02-0006	.500-14 NPT X 2-WAY VALVE	5
2	02-03-0005	STTC MIXER TO ATMZR HOSE	1
3	02-05-0005	FTTG CPLG .500 NPT FM SS	1
4	02-06-0010	FTTG 90 DEG .500HB X .500NPT ML NYL	1
5	02-06-0020	FTTG 90 DEG STRT.500NPTX .500NPT SS	4
6	02-07-0007	FTTG NIP .500NPTX1.125 TBE SS CLOSE	5
7	02-07-0019	FTTG NIP .500 NPT X 3.00 TBE SS	1
8	02-08-0007	FTTG STGHT .500HB X .500NPT ML NYL	1
9	02-11-0001	FTTG CROSS .500 NPT FM SS	2
10	02-15-0013	FTTG CPLG .500 HB QCK DISC BODY	1
11	02-15-0014	FTTG CPLG .500 NPT QCK DISC INSERT	4
12	04-03-0030	MXR IL PVC 6ELEMENT .500PIPE X 7.00	1
13	05-10-2891	STATIC MIXER & MNFLD MNT BRKT	1
14	05-10-4277	SPCR STTC MXR MNT	1
15	06-01-0037	BOLT U .313-18 X 1.38 X 2.188 ZP	2
16	06-03-0002	NUT NYL LOCK .313-18 ZP GR5	4
17	06-07-0006	CLMP HOSE .500 TO .906 X .313W ZP	2

LPV SEED TREATER

DRUM ASSEMBLY

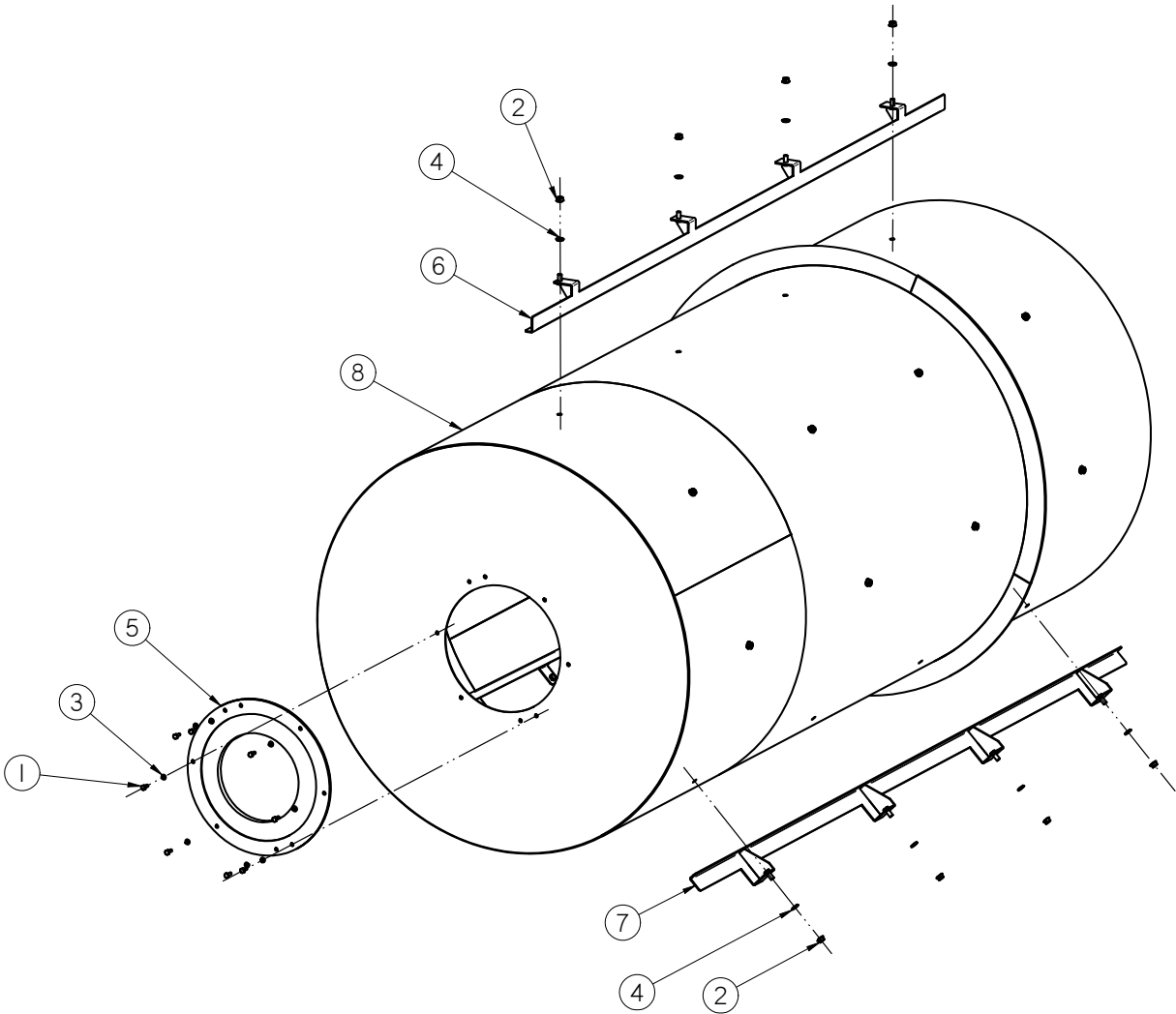

LPV DRUM ASSEMBLY		LPV 8FT CS		LPV 8FT SS	
		18-01-0257		18-01-0335	
Item #	Description	Part #	Qty	Part #	Qty
1	BOLT .250-20	06-01-0006	8	06-01-0051	8
2	NUT LOCK FLG .375-16 ZP GR5	06-03-0014	32	06-03-0014	32
3	WASHER, LOCK, SPLIT .250	06-04-0001	8	06-04-0009	8
4	WASHER, SS, BONDED, SEALING .375 ID	06-04-0013	32	06-04-0013	32
5	ASSY DRUM INLET BRUSH	13-08-0534	1	13-08-0534	1
6	WELDMENT, DRUM PADDLE, SHORT	18-01-0192	4	18-01-0193	4
7	WELDMENT, DRUM PADDLE, TALL	18-01-0194	4	18-01-0195	4
8	WELDMENT, DRUM LPV 8FT	18-01-0246	1	18-01-0336	1

LPV SEED TREATER

8 FT BASE FRAME ASSEMBLY (18-01-0250)

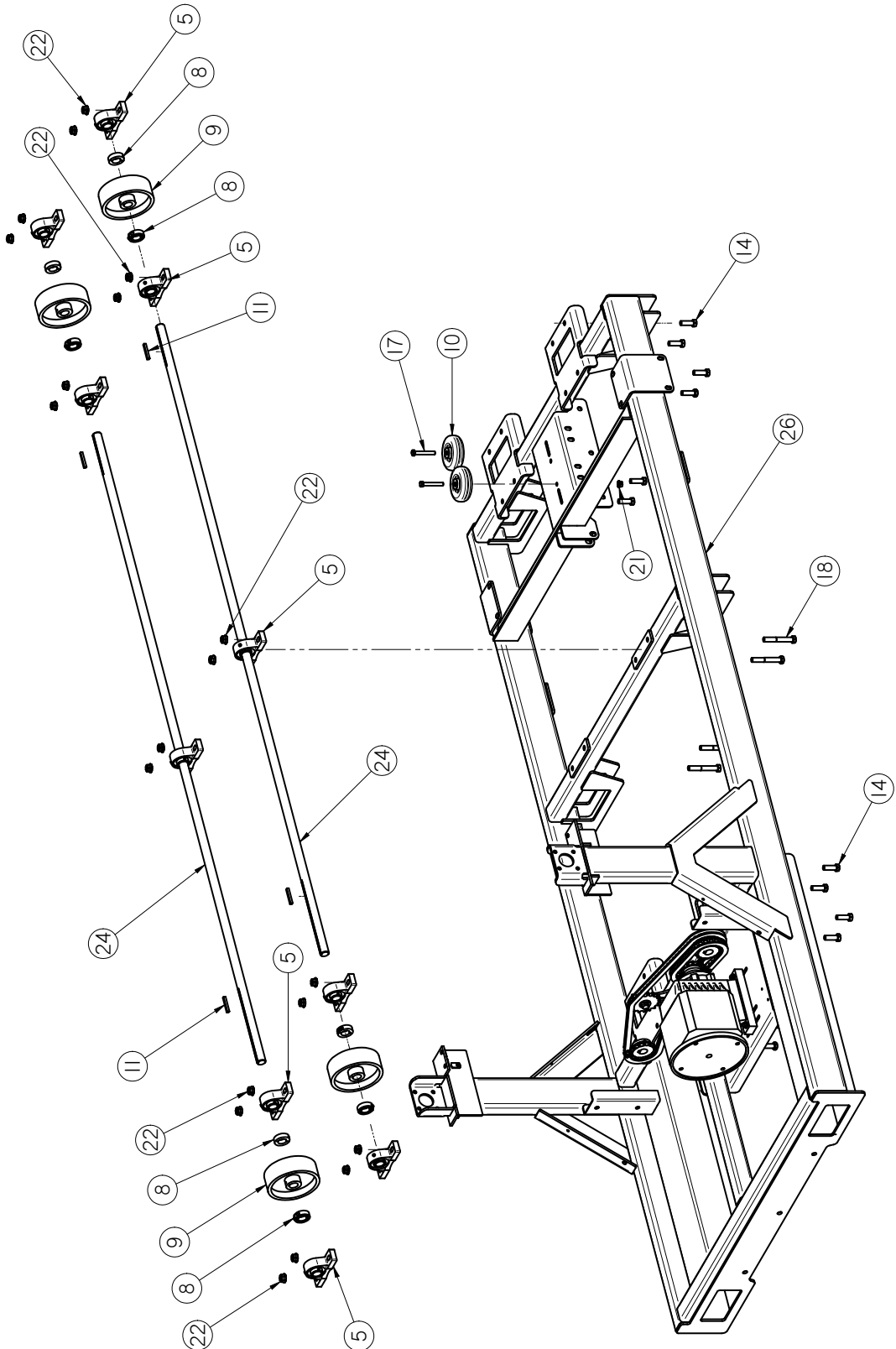

LPV SEED TREATER
8 FT BASE FRAME ASSEMBLY (18-01-0250)

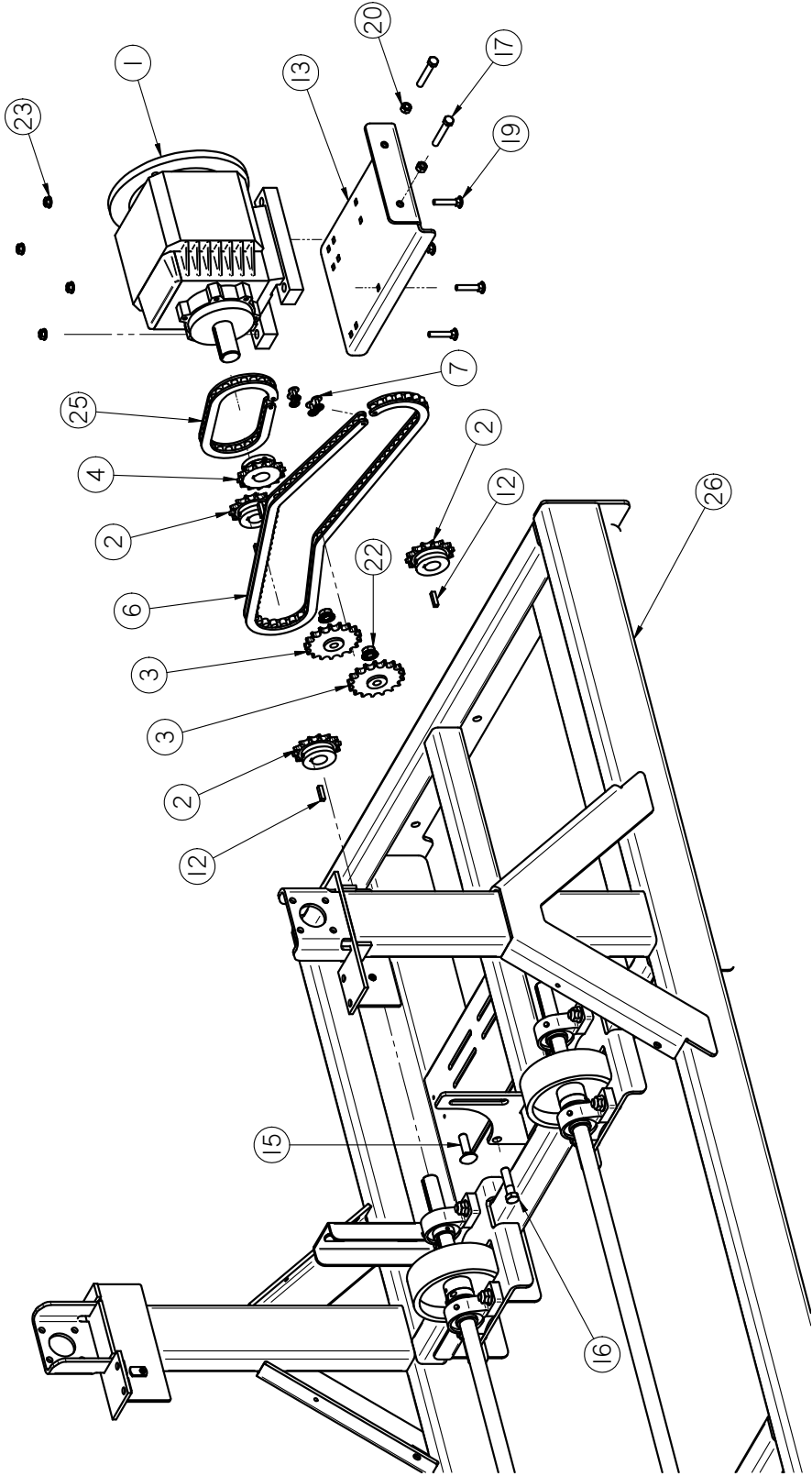

LPV SEED TREATER

8 FT BASE FRAME ASSEMBLY (18-01-0250)

Item #	Part #	Description	Qty
1	01-01-0167	GBOX IL 182-4TC 16.6:1 GR B1 FT MNT	1
2	01-02-0093	SPROCKET # 50 14T 1.00 IN BORE TYPE B	3
3	01-02-0095	SPKT 17T 50P .500 ID IDLER	2
4	01-02-0117	SPROCKET # 50 14T 1.25 IN BORE TYPE B	1
5	01-03-0036	BRG PLW 1.00ID STSC SEALED	10
6	01-04-0002	#50 CHAIN 53.5" LG	1
7	01-04-0005	CHAIN CTNG LINK 50P	2
8	01-05-0008	SHAFT CLR 1.00ID SPLIT	8
9	01-06-0002	WHL DRV 6 X 2 X 1.00ID .250KWY	4
10	01-06-0152	WHL GUIDE .375ID X 4.00 X .1.50 NPRN	2
11	01-10-0003	KEY .250 X 2.00 CS	4
12	01-10-0004	KEY .250 X 1.00 CS	4
13	05-04-0067	WDMT DRUM DRV ADJ PLT	1
14	06-01-0025	BOLT .500-13 X 1.50 ZP GR5	16
15	06-01-0026	BOLT CRG .500-13 X 1.75 ZP GR5	1
16	06-01-0027	BOLT .500-13 X 2.00 ZP GR5	1
17	06-01-0071	BOLT .375-16 X 2.50 ZP GR5	4
18	06-01-0147	BOLT .500-13 X 3.50 ZP GR5	4
19	06-01-0172	BOLT CRG .313-18 X 1.75 ZP GR5	4
20	06-02-0003	NUT FULL .375-16 ZP GR5	2
21	06-03-0014	NUT LOCK FLG .375-16 ZP GR5	2
22	06-03-0015	NUT LOCK FLG .500-13 ZP GR5	22
23	06-03-0019	NUT, FLG .3125-18 UNC ZP GRADE 5	4
24	10361A	DRUM DRV SHAFT LPV 8 FT	2
25	13-05-0157	#50 CHAIN -- 32 LINKS	1
26	18-01-0248	WDMT BASE FR 8 FT	1

LPV SEED TREATER
DRUM GUARDS ASSEMBLY (18-01-0313)

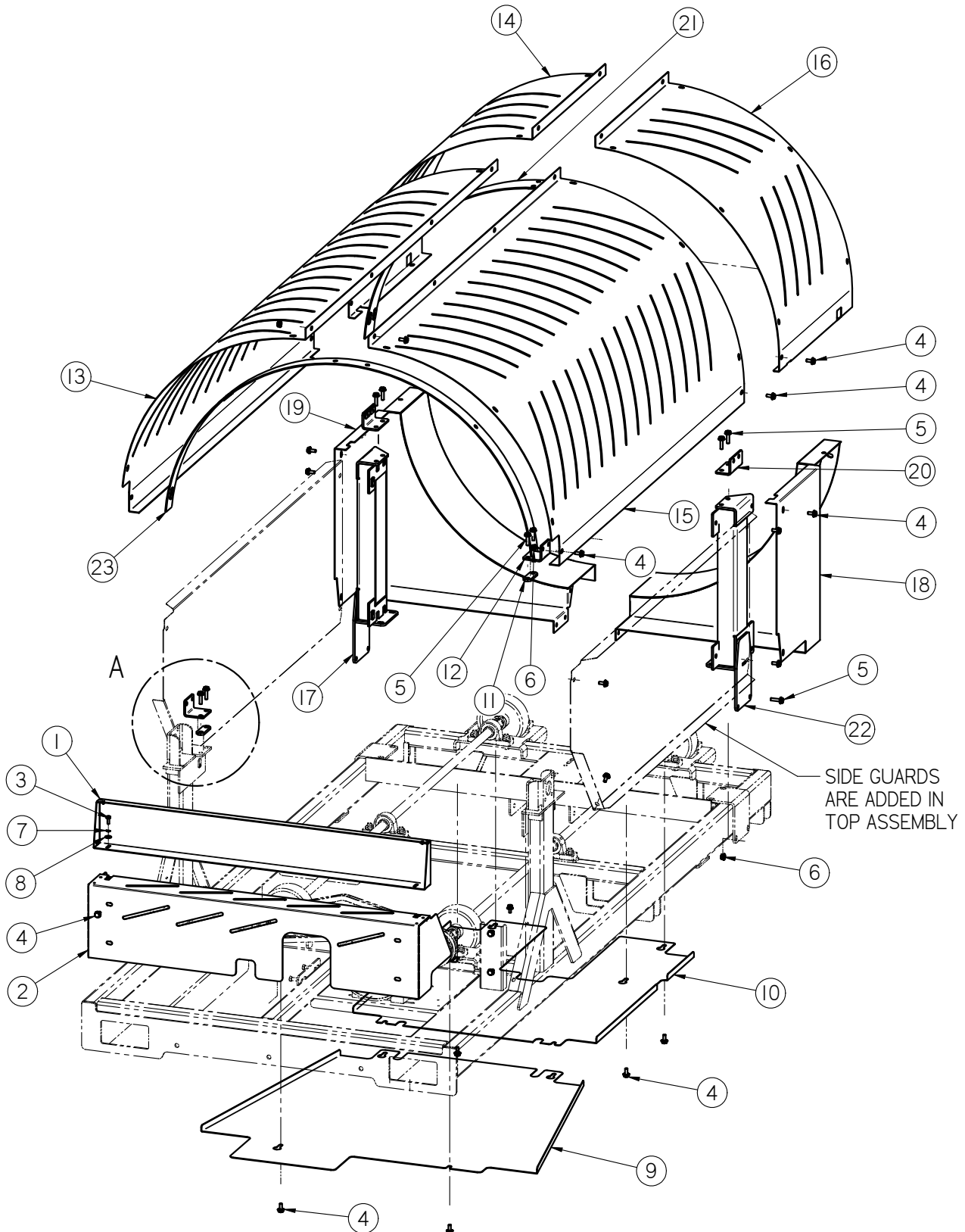

LPV SEED TREATER

DRUM GUARDS ASSEMBLY (18-01-0313)

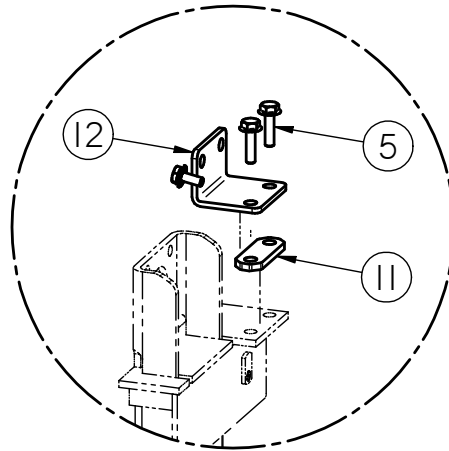

DETAIL A

Item #	Part #	Description	Qty
1	05-06-0093	TOP SHD CHAIN GRD GALV	1
2	05-06-0105	FRNT SHD, CHAIN GRD GALV	1
3	06-01-0003	BOLT, .250-20 X .750 UNC 18-8 SS	2
4	06-01-0124	BOLT FLG .375-16 X .750 ZP GR5	59
5	06-01-0189	BOLT FLG .375-16 X 1.250 ZP GR5	16
6	06-03-0014	NUT LOCK FLG .375-16 ZP GR5	21
7	06-04-0001	WSHR LOCK SPLT .250 ZP	2
8	06-05-0001	WASHER, FLAT .250	2
9	103615	GRD DRUM BTM FRNT HALF LPV 8FT	1
10	103616	GRD DRUM BTM REAR HALF LPV 8FT	1
11	103BD4	SPACER	2
12	103BD7	BRKT	2
13	103BED	GRD	1
14	103BEE	GRD	1
15	103BF1	GRD	1
16	103BF2	GRD	1
17	18-01-0306	WDMT GRD SUPP	1
18	18-01-0307	WDMT GRD	1
19	18-01-0308	WDMT GRD	1
20	18-01-0310	WDMT BRKT	2
21	18-01-0311	WDMT GRD CONNECTOR	1
22	18-01-0312	WDMT GRD SUPP	1
23	18-01-0317	WDMT GRD STIFFENER	1

LPV SEED TREATER
LPV TREATER BASE ASSEMBLY (18-01-0314)

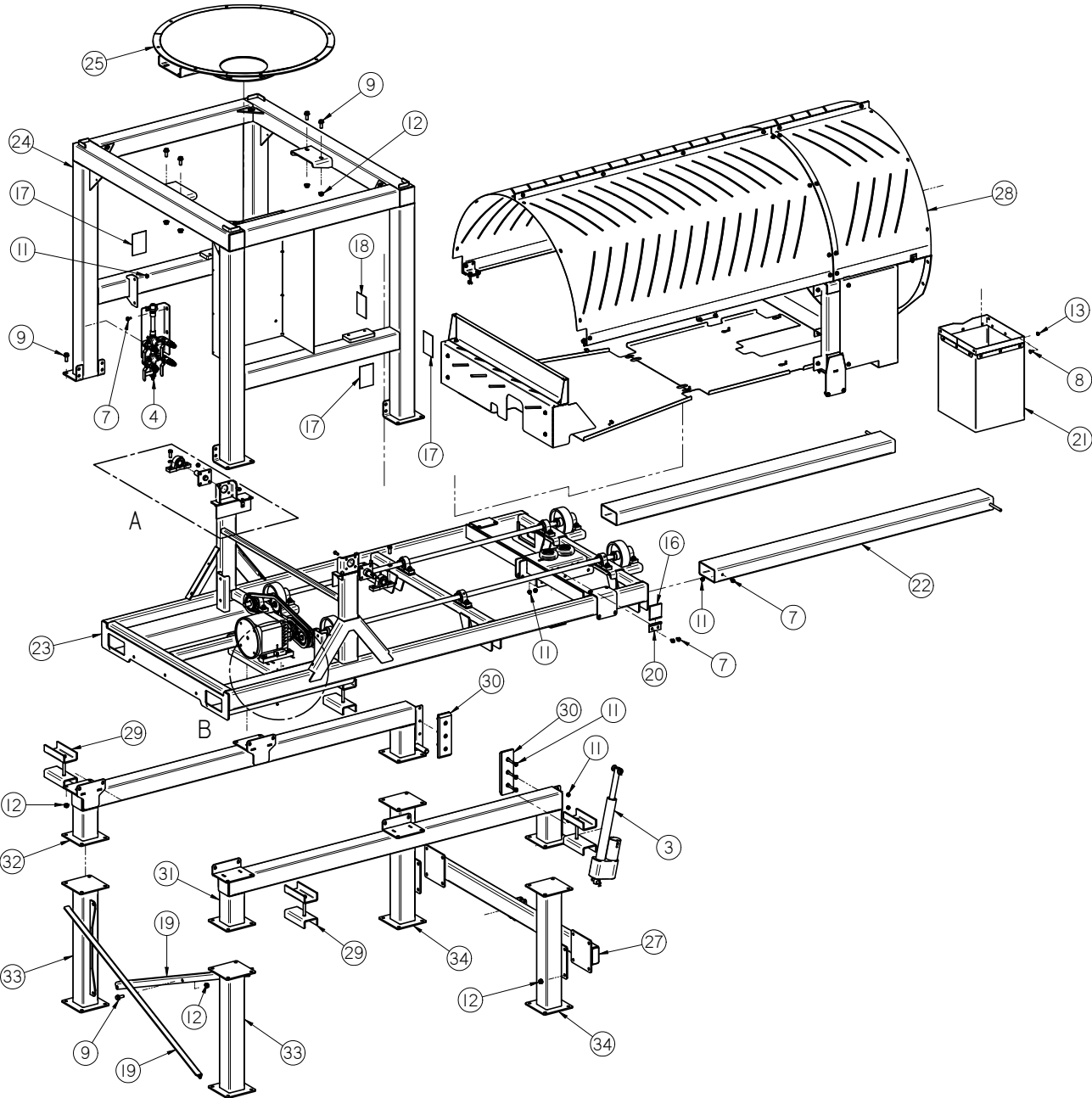

LPV SEED TREATER
LPV TREATER BASE ASSEMBLY (18-01-0314)

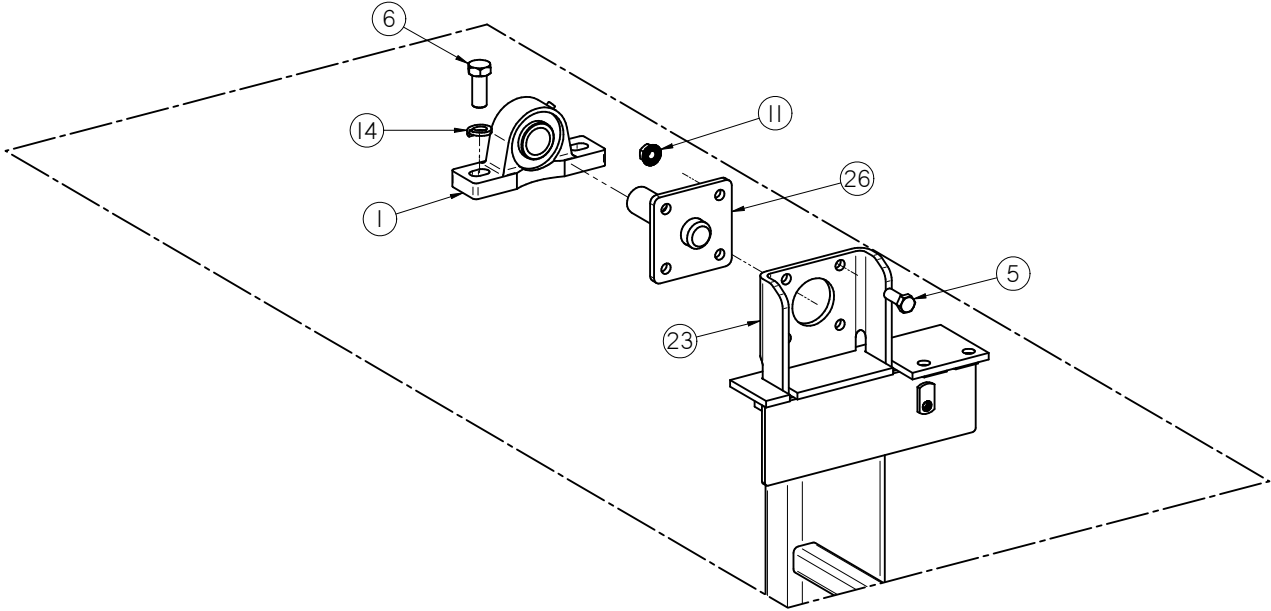

DETAIL A

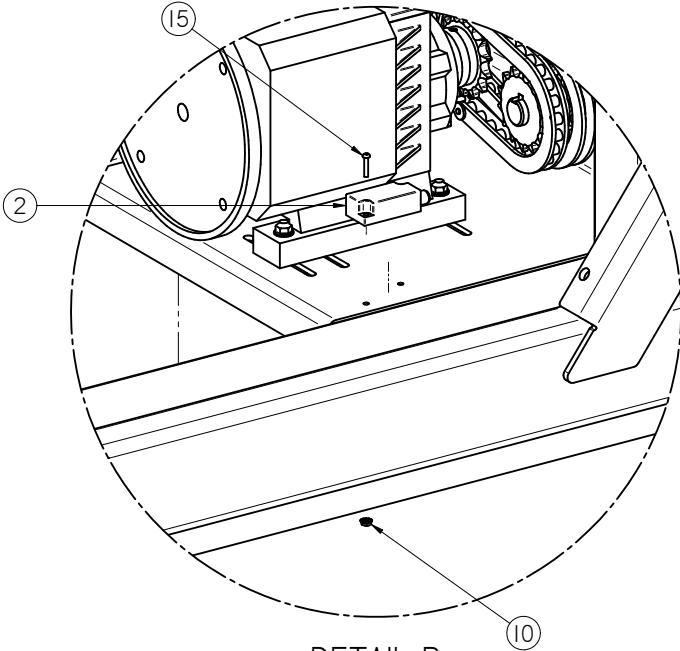

DETAIL B

LPV SEED TREATER

LPV TREATER BASE ASSEMBLY (18-01-0314)

Item #	Part #	Description	Qty
1	01-03-0060	BRG PLW SEALED 1.00ID STSC	2
2	03-17-0105	TRCK INCLMTR B2N-10H-Q20L60-2LI2-	1
3	03-17-0111	ACTR 8"STRK 24VDC LPV TRTR DRUM KIT	1
4	04-03-0255	ASSY STTC MXR & VLVS LPV TRTR QD	1
5	06-01-0016	BOLT .375-16 X 1.00 ZP GR5	8
6	06-01-0080	BOLT .500-13 X 1.25 ZP GR5	4
7	06-01-0124	BOLT FLG .375-16 X .750 ZP GR5	20
8	06-01-0171	BOLT CRG .3125-18X.750 ZP SHORT NECK	4
9	06-01-0232	BOLT FLG .500-13 X 1.250 ZP GR5	49
10	06-02-0033	NUT 6-32 K-LOCK ZP	2
11	06-03-0014	NUT LOCK FLG .375-16 ZP GR5	26
12	06-03-0015	NUT LOCK FLG .500-13 ZP GR5	49
13	06-03-0019	NUT LOCK FLG .3125-18 ZP GR5	4
14	06-04-0004	WSHR LOCK SPLT .500 ZP	4
15	06-06-0088	SCRW MACH 6-32 X .750 PHLP RDHD ZP	2
16	06-10-0059	STATIC DISSIPATIVE BRUSH	1
17	09-02-0001	ATWK LBL DANGER FINGERS	3
18	09-02-0002	ATWK LBL DANGER GUARDS	1
19	103614	ANGLE CROSS BRACE	2
20	103D7E	BRUSH HOLDER	1
21	18-01-0072	ASSY END CHUTE EXT LPX	1
22	18-01-0107	WDMT FORKLIFT PCKT EXT 8FT	2
23	18-01-0250	ASSY BASE FR LPV 8FT	1
24	18-01-0251	WDMT FR STAND LPV	1
25	18-01-0252	WDMT INLET HOPP	1
26	18-01-0254	WDMT PIVOT PIN AVR	2
27	18-01-0304	WDMT ACTUATOR MNT	1
28	18-01-0313	KIT LPV DRUM GUARDS	1
29	18-01-0315	ASSY LPV DRM SHIPPING BRKT	4
30	18-01-0316	ASSY DRUM STABILIZER PAD	2
31	18-01-0339	WDMT LOWER LEG RH	1
32	18-01-0340	WDMT LOWER LEG LH	1
33	18-01-0341	WDMT LOWER LEG EXT X-BRACE MNT	2
34	18-01-0342	WDMT LOWER LEG EXT ACTR MNT	2

LPV SEED TREATER
DRUM ACTUATOR KIT ASSEMBLY (03-17-0111)

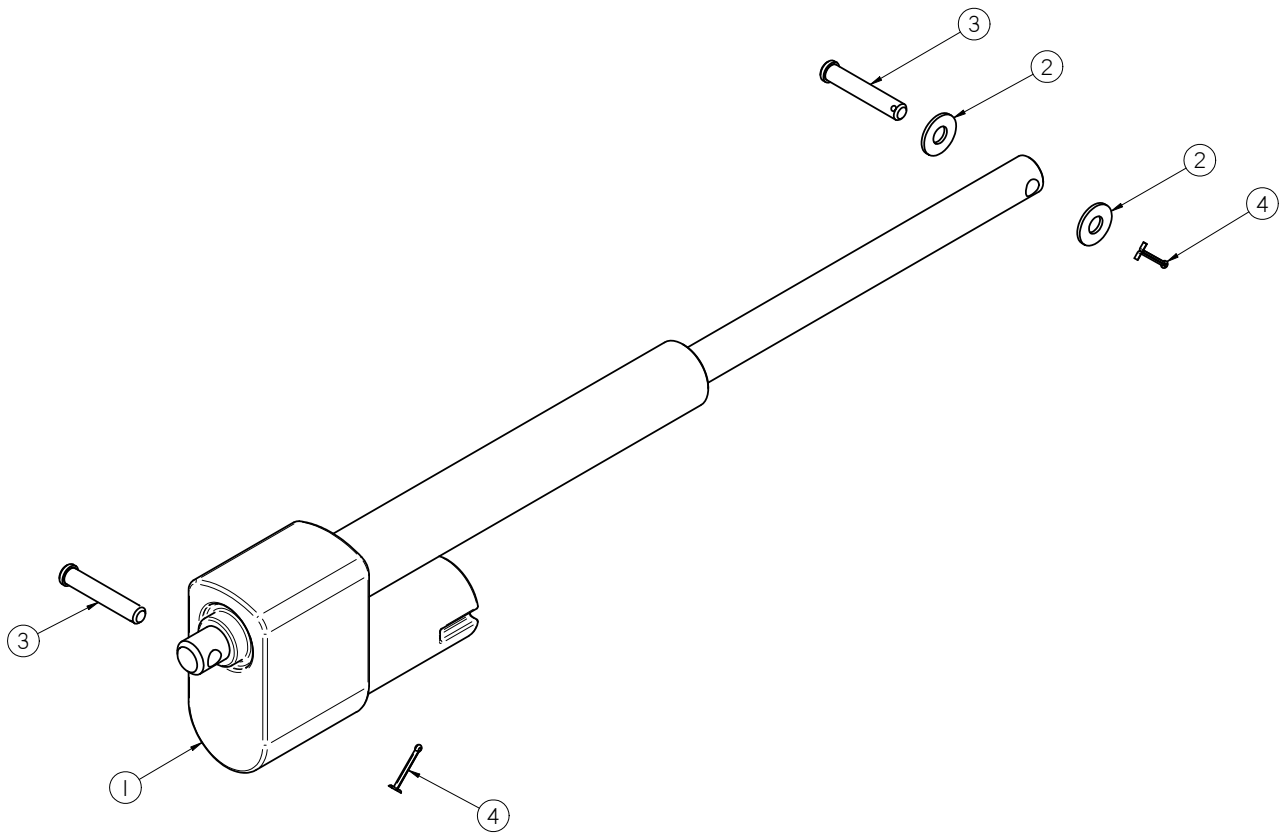

Item #	Part #	Description	Qty
1	03-17-0104	ACTR 8" STRK 24VDC MDC10-24-40-203-3	1
2	06-05-0005	WSHR FLAT .500 ZP	1
3	06-09-0058	WSHR FLAT .500 ZP	2
4	06-09-0087	PIN CLVS .500 X 2.75 PLN	2

NOTICE The following parts are in the motor kit but do not appear in the drawing view

Item #	Part #	Description	Qty
5	03-08-0246	CONN TURCK RSF-26-2M	1
6	03-08-0268	CONN COMPACT TNML BLK 2-CON 222-412	1
7	03-08-0269	CONN COMPACT TNML BLK 3-CON 222-413	1
8	06-03-0024	NUT LOCK 0.5 NPT FITTING	1

LPV SEED TREATER
ATOMIZER HEAD ASSEMBLY (04-02-0004)

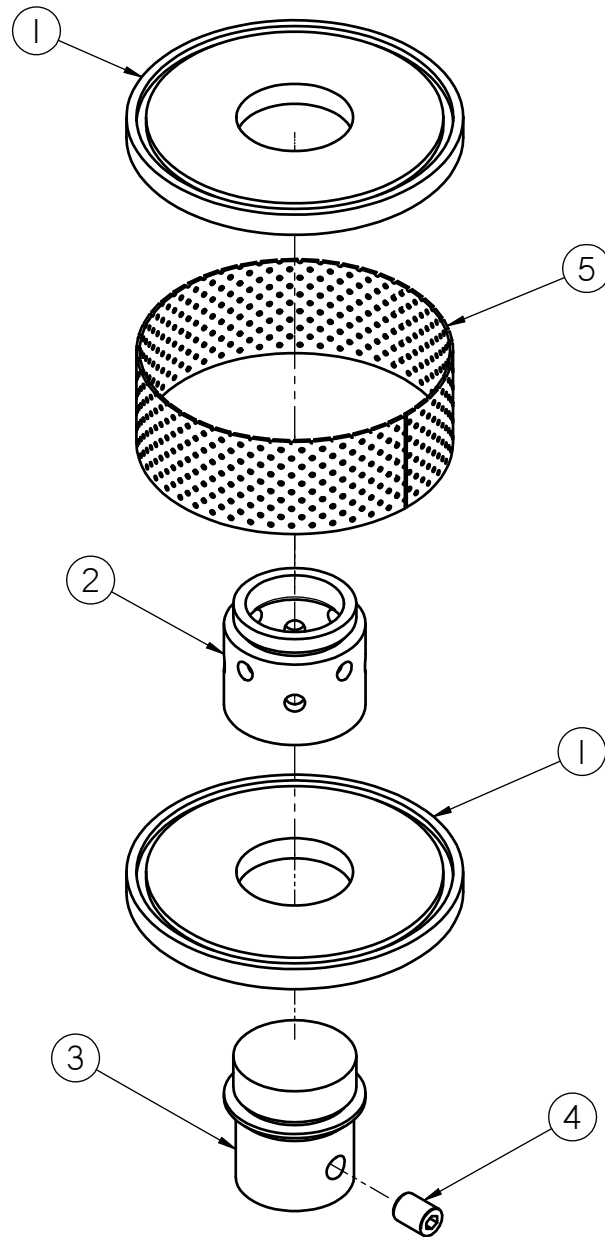

Item #	Part #	Description	Qty
1	05-11-0014	PLT ATMZR CAP	2
2	05-11-0015	ATOMIZER SPACER	1
3	05-11-0016	DRIVE SPUD, BOTTOM	1
4	06-06-0003	SET SCRW, CP, .375-16 18-8 SS .50	1
5	13-05-0032	PERFORATED SCREEN, STD.	1

LPV SEED TREATER
ATOMIZER ASSEMBLY (18-01-0318)

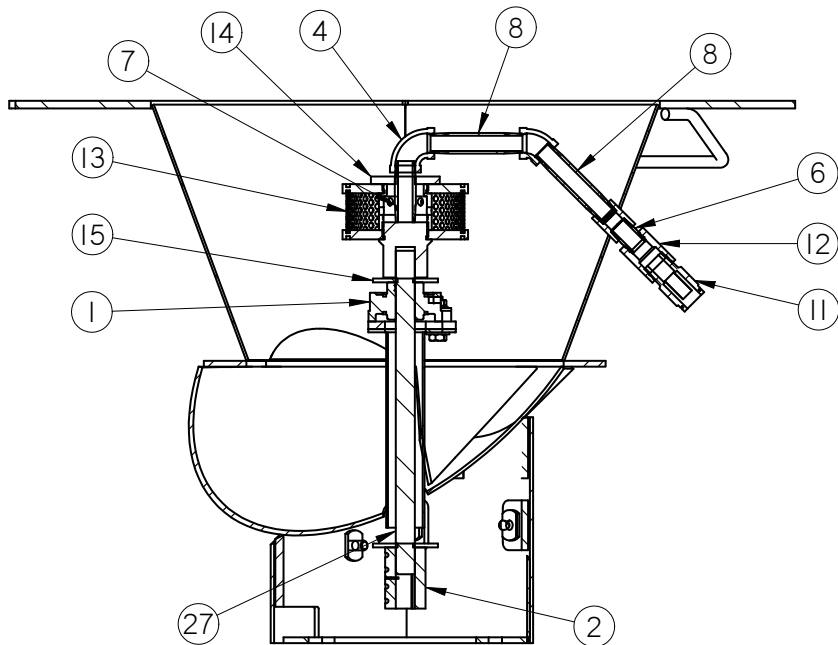
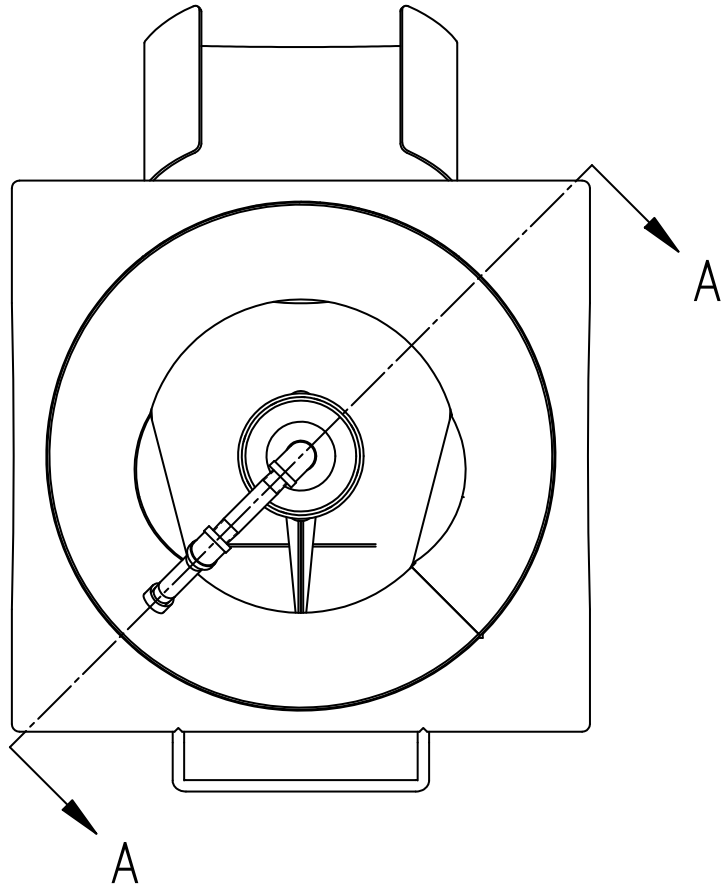

SECTION A-A

LPV SEED TREATER
ATOMIZER ASSEMBLY (18-01-0318)

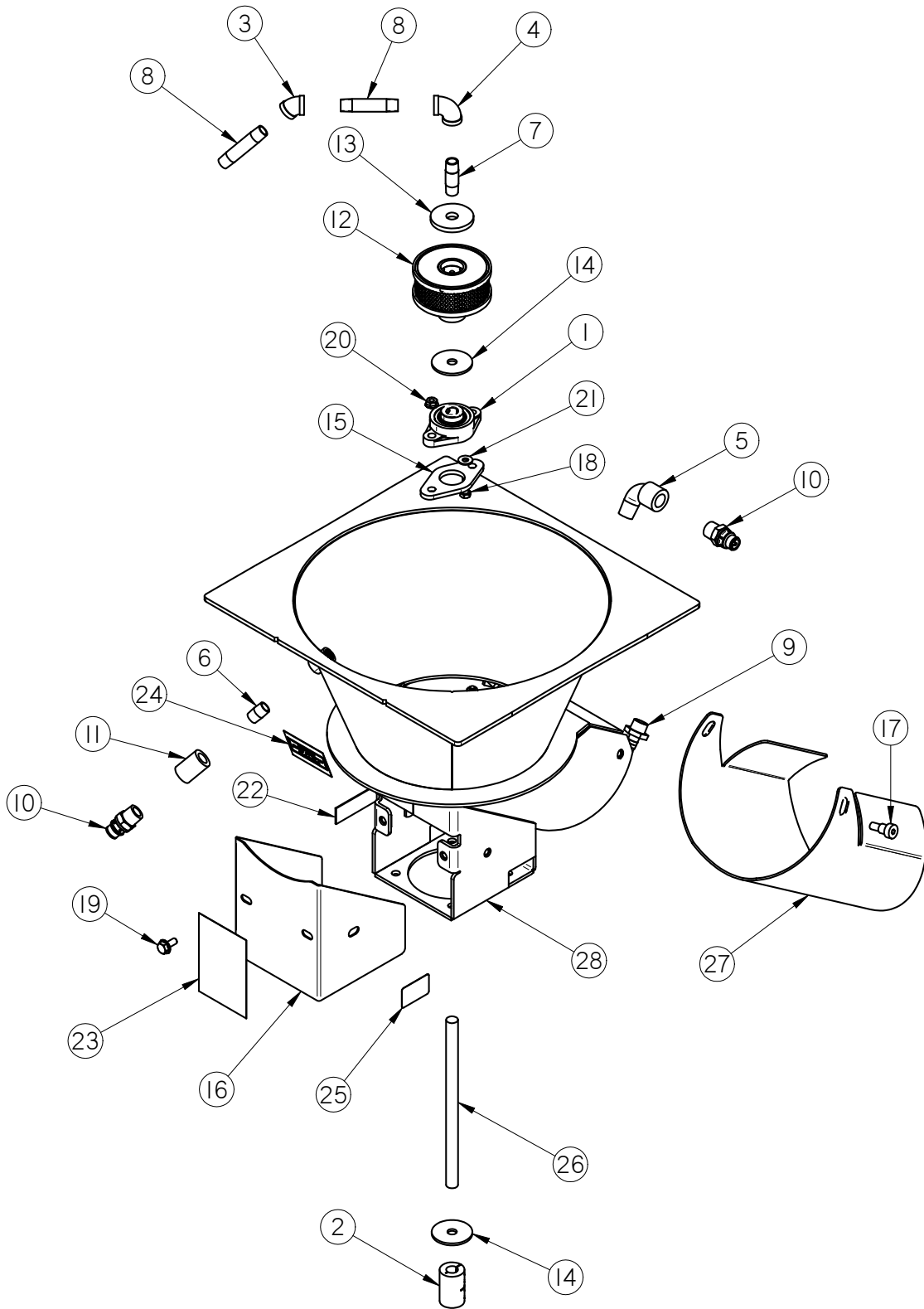

LPV SEED TREATER

ATOMIZER ASSEMBLY (18-01-0318)

Item #	Part #	Description	Qty
1	01-03-0002	BRG FLG MNT .625ID 3.875 BASE	1
2	01-07-0027	CPLG CLPN .625 X .625 SPLT CS	1
3	02-06-0007	FTTG 45 DEG .375NPT SS	1
4	02-06-0008	FTTG 90 DEG .375NPT FM SS	1
5	02-06-0017	FTTG 90 DEG STRT .500NPT PPE BLK	1
6	02-07-0001	FTTG NIP .375 NPT X 1.00 TBE SS	1
7	02-07-0003	FTTG NIP .375 NPT X 2.00 TBE SS	1
8	02-07-0020	FTTG NIP .375 NPT X 3.00 TBE SS	2
9	02-08-0007	FTTG STGHT .500HB X .500NPT ML NYL	1
10	02-15-0014	FTTG CPLG .500 NPT QCK DISC INSERT	2
11	02-16-0052	FTTG CPLG RDCG .500NPT X .375NPT SS	1
12	04-02-0004	ASSY,ATOMIZER HEAD,4" COTTON	1
13	05-10-0360	DISC STD ATMZR HEAD CVR	1
14	05-10-0805	DISK ATOMIZER MOTOR	2
15	05-10-2462	SEAL RBBR .625 FLG BRG	1
16	05-10-4029	GRD ATMZR MTR LPX SS	1
17	06-01-0056	BOLT SHLD .500SHX.375-16X.500 GR5	2
18	06-01-0102	BOLT .313-18 X 1.25 ZP GR5	2
19	06-01-0124	BOLT FLG .375-16 X .750 ZP GR5	4
20	06-03-0019	NUT LOCK FLG .3125-18 ZP GR5	2
21	06-05-0001	WASHER, FLAT .250	2
22	09-01-0107	LBL ATWK PATENT DECAL-ATMZR	1
23	09-02-0002	ATWK LBL DANGER GUARDS	1
24	09-02-0004	ATWK LBL GRS 40HRS	1
25	09-02-0013	ATWK LBL ROTATION ARROW	1
26	101FAF	SHAFT DRV ATMZR LPX2000	1
27	103D73	LPV2000 ATMZR EXT CHUTE for Brush	1
28	18-01-0066	WDMT ATMZR LPX2000 SS	1

STANDARD ADJUSTABLE CHAMBER ASSEMBLY (18-01-0062)

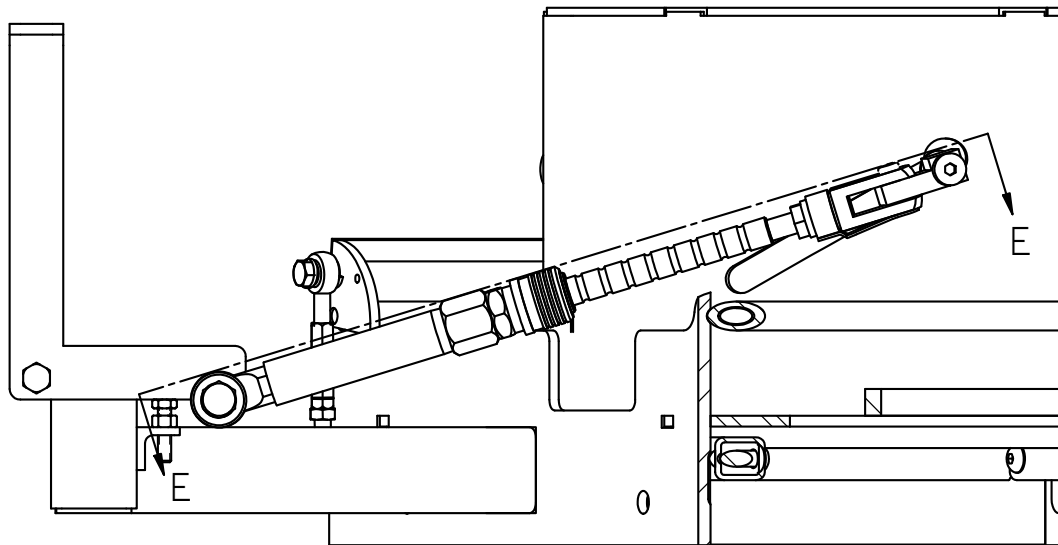
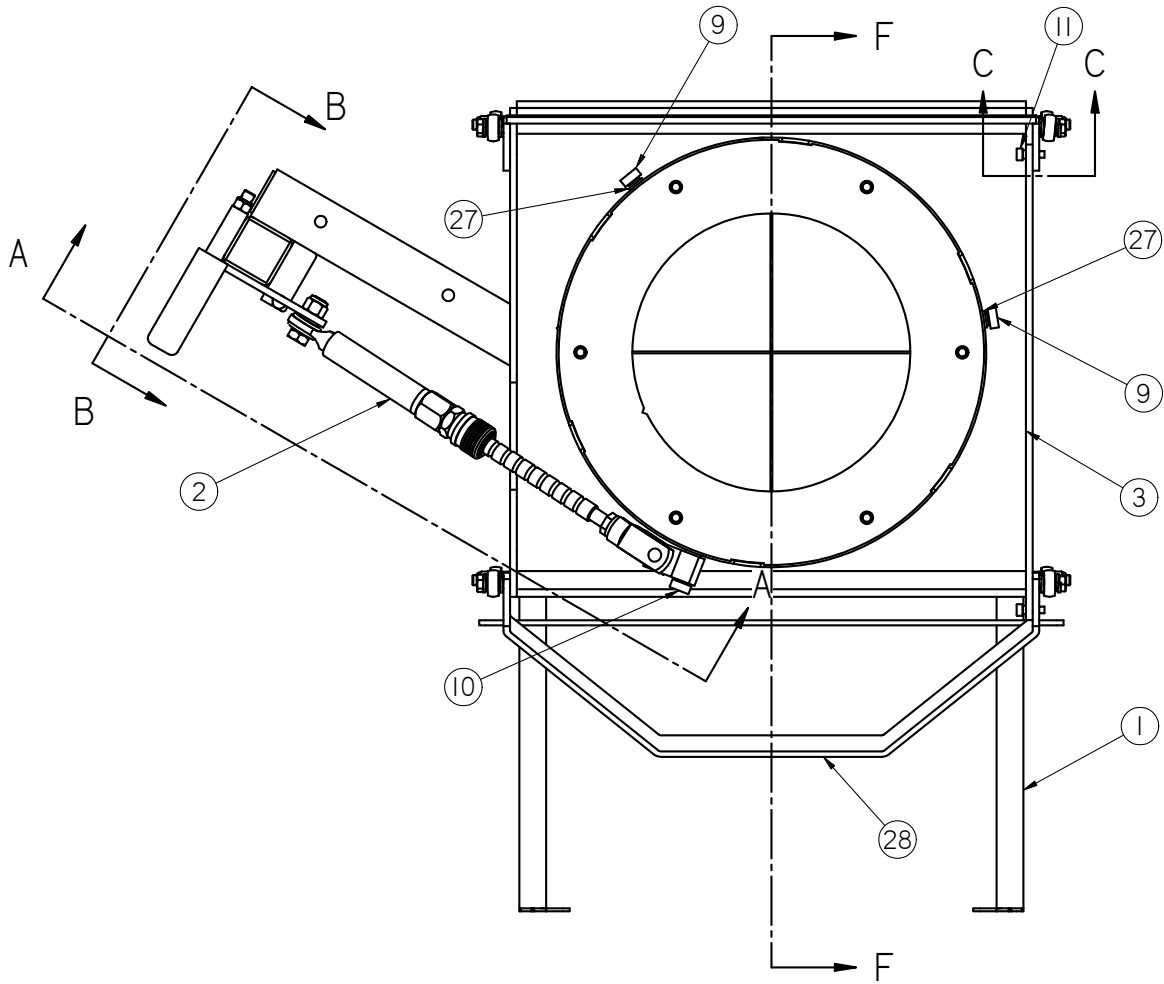

SECTION A-A

LPV SEED TREATER

STANDARD ADJUSTABLE CHAMBER ASSEMBLY (18-01-0062)

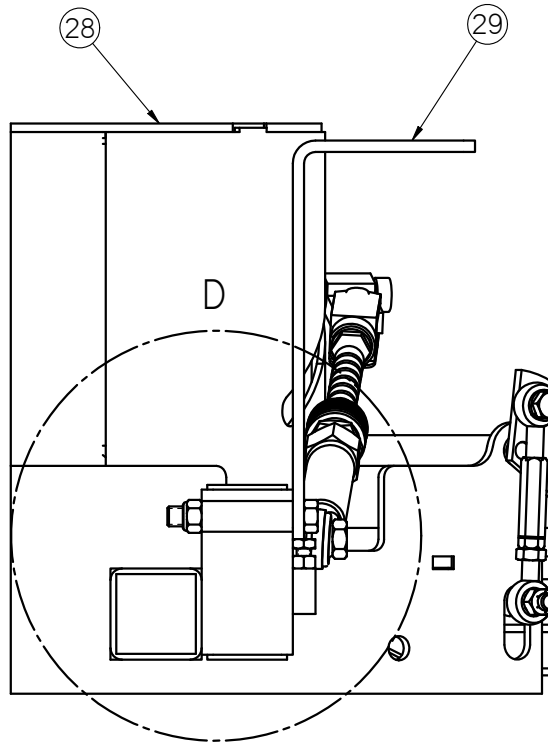

SECTION B-B

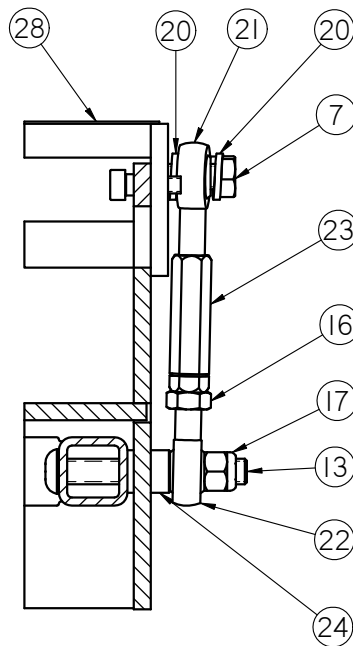

SECTION C-C

STANDARD ADJUSTABLE CHAMBER ASSEMBLY (18-01-0062)

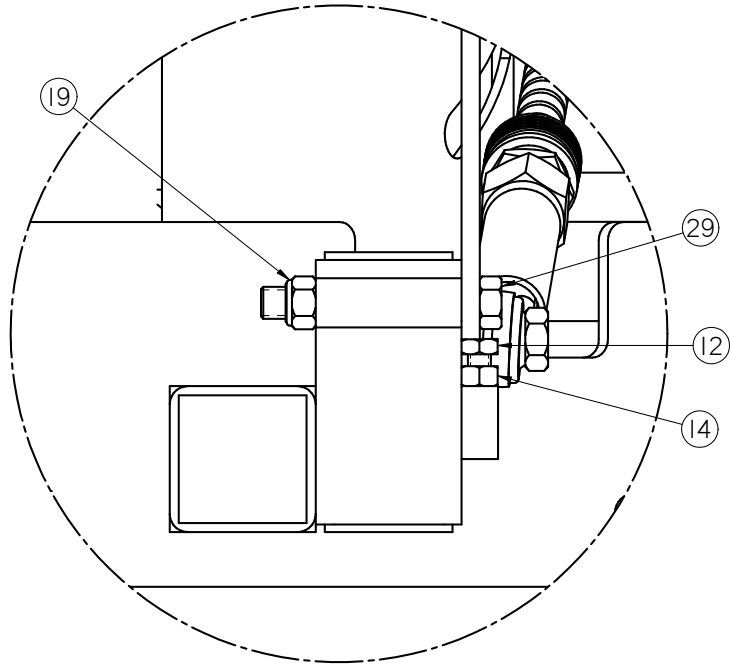

DETAIL D

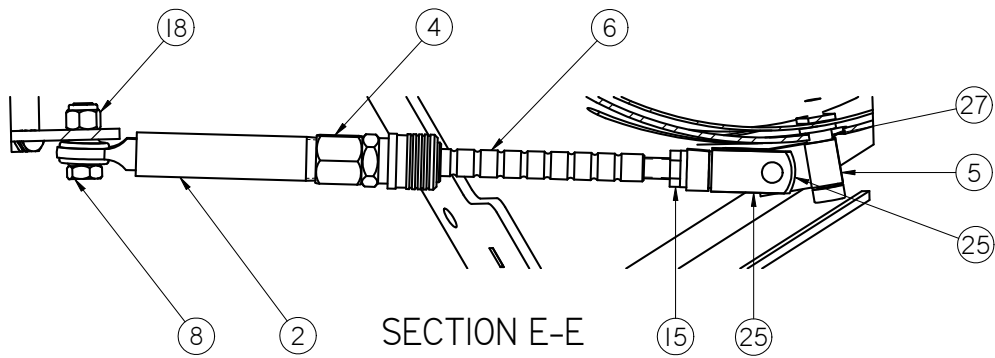

SECTION E-E

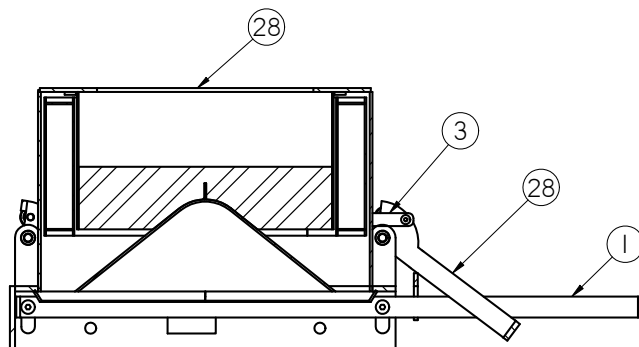

SECTION F-F

LPV SEED TREATER

STANDARD ADJUSTABLE CHAMBER ASSEMBLY (18-01-0062)

Item #	Part #	Description	Qty
1	05-03-0336	WDMT,CHAMBER SUPPORT BRK SS	1
2	05-04-0012	WDMT FLOW SLV ROD END TUBE	1
3	05-10-2062	BAR ECNTRC CONNECTING CS	1
4	05-11-0029	CPLG QCK CONNECT MACH	1
5	05-11-0030	BRKT FLOW CNTL CLEVIS	1
6	05-11-0034	ROD FLOW STOP ADJ	1
7	06-01-0016	BOLT .375-16 X 1.00 ZP GR5	4
8	06-01-0025	BOLT .500-13 X 1.50 ZP GR5	1
9	06-01-0056	BOLT SHLD .500SHX.375-16X.500 GR5	2
10	06-01-0057	BOLT SHLD .500SHX.375-16X1.50 GR5	1
11	06-01-0081	BOLT SHLD .313SHX.250-20X.375 GR5	2
12	06-01-0102	BOLT .313-18 X 1.25 ZP GR5	1
13	06-02-0002	NUT FULL .313-18 ZP GR5	1
14	06-02-0015	NUT JAM .500-20 ZP GR5	1
15	06-02-0035	NUT JAM .375-24 ZP GR5	4
16	06-03-0003	NUT NYL LOCK .375-16 ZP GR5	4
17	06-03-0004	NUT NYL LOCK .500-13 ZP GR5	1
18	06-03-0006	NUT NYL LOCK .438-14 ZP GR5	1
19	06-04-0003	WSHR LOCK SPLT .375 ZP	8
20	06-06-0087	SCRW BTN SCKT HD .375-16X2.75 ZP	4
21	06-12-0002	REND .375-24 BALL RH	4
22	06-12-0003	REND .375-24 BALL RH	4
23	06-12-0006	ROD CTNG .375-24 X 2.00 LH RH FM	4
24	06-12-0007	BUSH DRILL.375ID X .625OD X .375	4
25	06-12-0008	CLVS .500-20 X .500	1
26	06-12-0009	PIN CLIP SPRING .500	1
27	06-12-0012	BUSH FLG BRZ .500ID X .625OD X .375	3
28	18-01-0060	WDMT ADJ CHMBR LPX2000 CS	1
29	18-01-0108	WDMT FLOW SLV HNDL LPX	1

LPV SEED TREATER

LOSS-IN-WEIGHT ADJUSTABLE CHAMBER ASSEMBLY (18-01-0283)

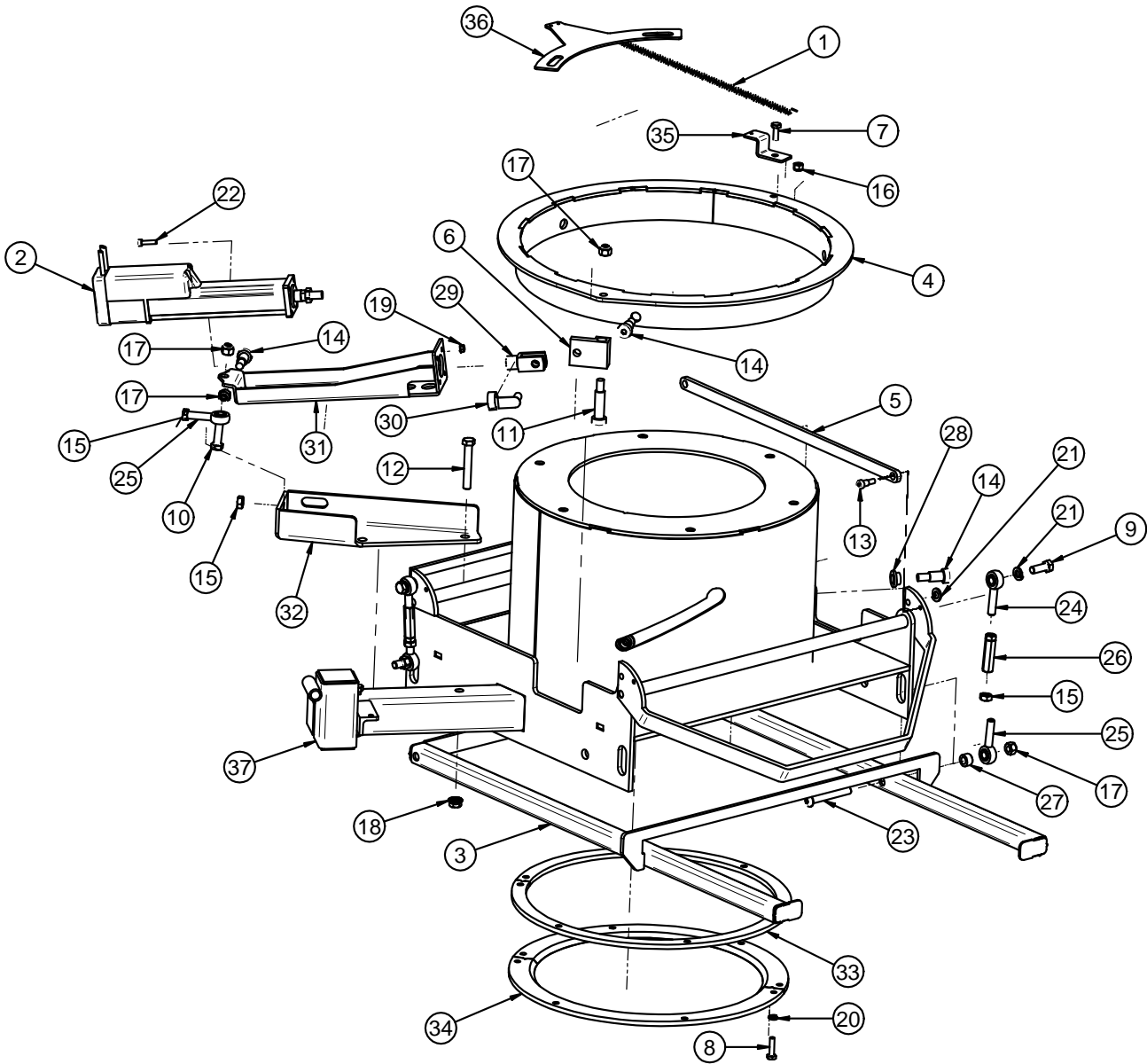

Item #	Part #	Description	Qty
1	01-04-0093	SPG EXT .500D .055 WIRE 5.0IN LG	1
2	03-20-0162	KIT ACTR W CONNECTORS	1
3	05-03-0336	WDMT,CHAMBER SUPPORT BRK SS	1
4	05-04-0169	WDMT RING DRV LIW SLEEVE	1
5	05-10-2062	BAR ECNTRC CONNECTING CS	1

LPV SEED TREATER

LOSS-IN-WEIGHT ADJUSTABLE CHAMBER ASSEMBLY (18-01-0283)

Item #	Part #	Description	Qty
6	05-11-0394	BRKT FLOW CNTL CLVS 10 MM	1
7	06-01-0006	BOLT .250-20 X .750 ZP GR5	1
8	06-01-0007	BOLT, .250-20 X 1 UNC ZP GRADE 5	8
9	06-01-0016	BOLT .375-16 X 1.00 ZP GR5	4
10	06-01-0053	BOLT .375-16 X 1.25 ZP GR5	1
11	06-01-0057	BOLT SHLD .500SHX.375-16X1.50 GR5	1
12	06-01-0071	BOLT .375-16 X 2.50 ZP GR5	2
13	06-01-0081	BOLT SHLD .313SHX.250-20X.375 GR5	2
14	06-01-0278	BOLT SHLD .500SHX.375-16X.750 GR5	4
15	06-02-0035	NUT JAM .375-24 ZP GR5	6
16	06-03-0001	NUT,LOCK, .250-20 ZP G5 NYLON INSERT	1
17	06-03-0003	NUT NYL LOCK .375-16 ZP GR5	7
18	06-03-0014	NUT LOCK FLG .375-16 ZP GR5	2
19	06-03-0031	NUT LOCK FLG M5-0.8 GR8.8	4
20	06-04-0001	WSHR LOCK SPLT .250 ZP	8
21	06-04-0003	WSHR LOCK SPLT .375 ZP	8
22	06-06-0083	SCRW SH M5-0.8 X 20MM BO	4
23	06-06-0087	SCRW BTN SCKT HD .375-16X2.75 ZP	4
24	06-12-0002	REND .375-24 BALL RH	4
25	06-12-0003	REND .375-24 BALL RH	5
26	06-12-0006	ROD CTNG .375-24 X 2.00 LH RH FM	4
27	06-12-0007	BUSH DRILL.375ID X .625OD X .375	4
28	06-12-0012	BUSH FLG BRZ .500ID X .625OD X .375	3
29	06-12-0043	CLVS 10-1.25 X 10MM	1
30	06-12-0044	PIN CLIP SPRING 10MM	1
31	102EEA	BRKT DYATIC SCN5-010-150 ACTUATOR	1
32	102EEB	BRKT CYL BASE	1
33	1044AB	SPACER	2
34	1044EB	SEAL	2
35	10501D	SPRING BRKT	1
36	105020	SPRING BRKT	1
37	18-01-0060	WDMT ADJ CHMBR LPX2000 CS	1

LPV SEED TREATER
PRO BOX WITH SCALE ASSEMBLY 18-01-0319

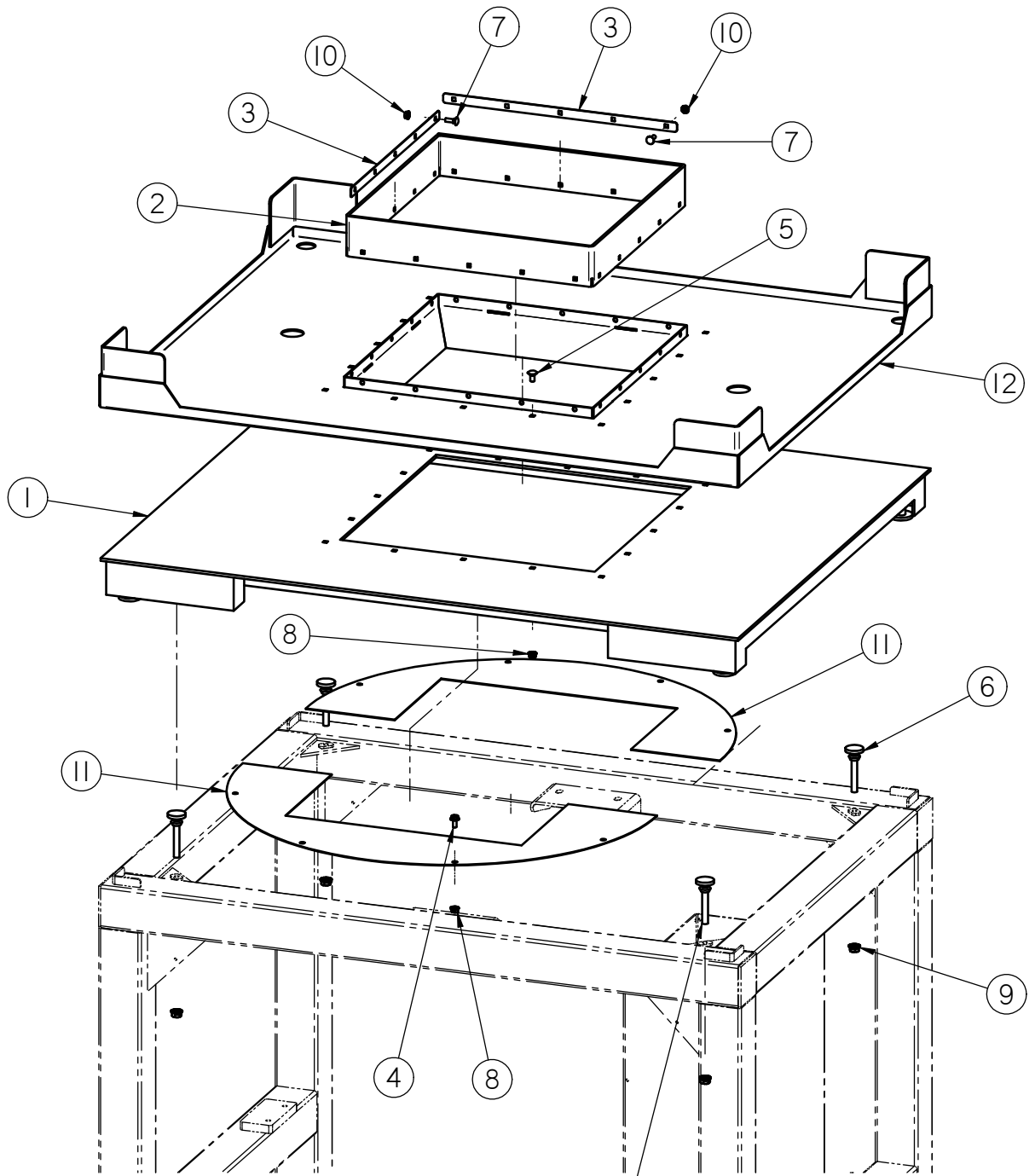

LEVELING PADS TO TAKE THE WEIGHT OFF THE LOADCELLS FOR SHIPPING

LPV SEED TREATER

PRO BOX WITH SCALE ASSEMBLY 18-01-0319

Item #	Part #	Description	Qty
1	03-19-0066	SCL 5X4FT 5K 2FT CTR CUTOUT*	1
2	05-10-4270	GUIDE RBBR LIW SCALE HOPP	1
3	05-10-4271	PLT CLAMP HOPP FLEX INLET	4
4	06-01-0124	BOLT, FLG .375-16 UNC ZP GRADE 5; 3/4" LG	8
5	06-01-0153	BOLT CRG .375-16X.750 ZP SHORT NECK	16
6	06-01-0176	LEVELING MNT CUSHION .500-13 200LB	4
7	06-01-0223	BOLT CRG .313-18 X 1.00 ZP GR5	20
8	06-03-0014	NUT LOCK FLG .375-16 ZP GR5	24
9	06-03-0015	NUT LOCK FLG .500-13 ZP GR5	4
10	06-03-0019	NUT, FLG .3125-18 UNC ZP GRADE 5	20
11	103EA2	COVER	2
12	18-01-0253	WDMT HOPP SCALE GUIDE	1

LPV SEED TREATER

LPV TREATER WITH LOSS-IN-WEIGHT TOP ASSEMBLY

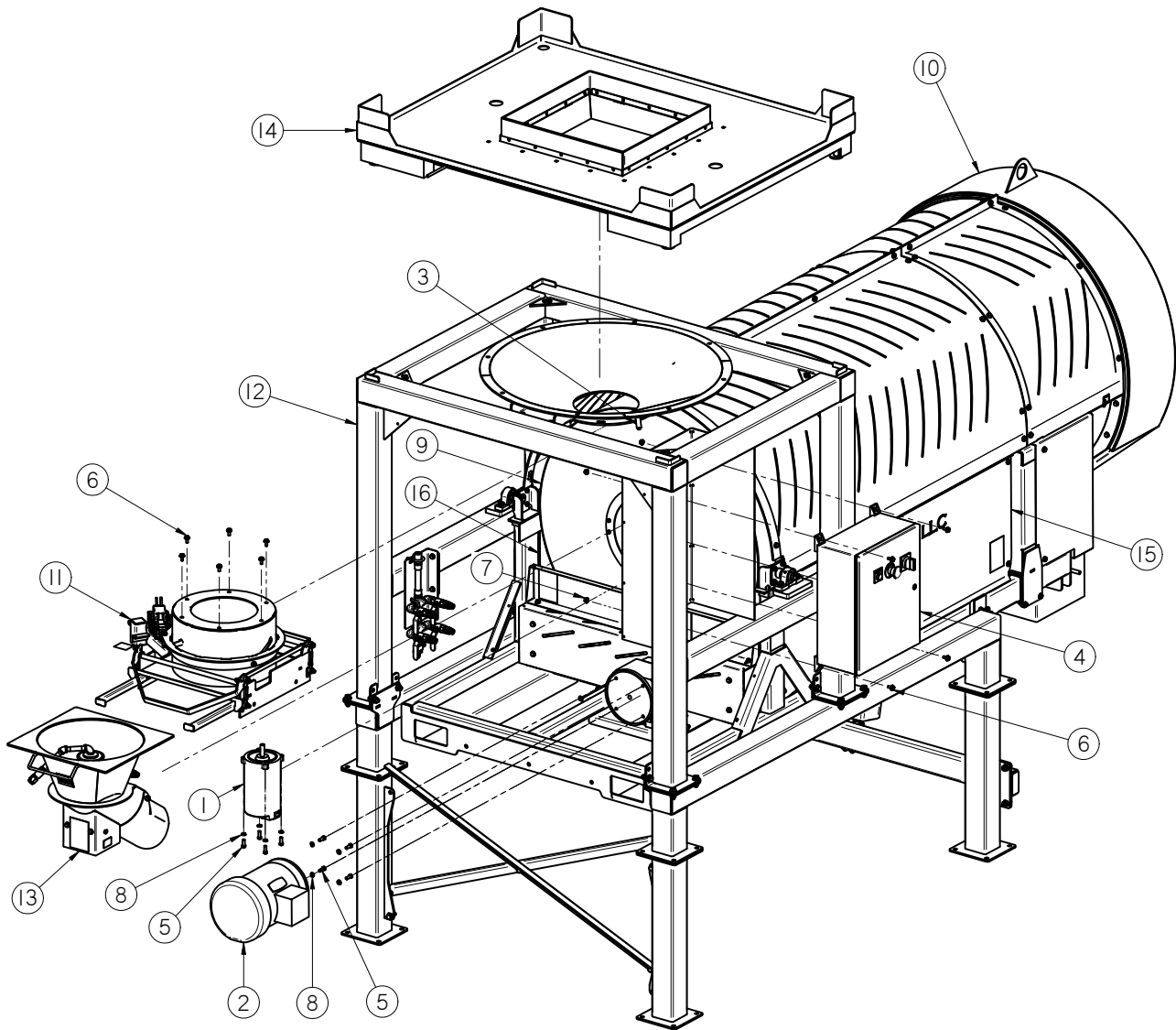

LPV SEED TREATER

LPV TREATER WITH LOSS-IN-WEIGHT TOP ASSEMBLY

Item #	Part #	Description	Qty
1	SEE TABLE 1	ATOMIZER MOTOR	1
2	SEE TABLE 2	DRUM MOTOR	1
3	03-10-0147	SENS PROX 24VDC AB QC 875CPN8NP18P3	1
4	03-12-0379	LPV LIW I/O Panel	1
5	06-01-0016	BOLT .375-16 X 1.00 ZP GR5	8
6	06-01-0124	BOLT FLG .375-16 X .750 ZP GR5	10
7	06-03-0014	NUT LOCK FLG .375-16 ZP GR5	4
8	06-04-0003	WSHR LOCK SPLT .375 ZP	8
9	18-01-0257	ASSY DRUM LPV 8FT CS	1
10	18-01-0270	ASSY END CHUTE LPV2000	1
11	18-01-0283	ASSY ADJ CHMBR LIW SO ATMZR 2000 CS	1
12	18-01-0314	ASSY LPV COMMON BASE	1
13	18-01-0318	ASSY ATMZR LPV SS	1
14	18-01-0319	ASSY SCALE W BOX MNT AND TRANS	1
15	18-01-0322	ASSY GRD DRUM LPV RT 8FT GALV	1
16	18-01-0325	ASSY GRD DRUM LPV LT 8FT GALV	1

TABLE 1

Part #	Description
01-01-0105	MTR .33HP 1725RPM 56C 3PH TENV
01-01-0105	MTR .33HP 1725RPM 56C 3PH TENV
01-01-0144	MTR .50 HP 1725 RPM 56C 575V TENV

TABLE 2

Part #	Description
01-01-0166	MTR 3HP 1740RPM 182TC TEFC 3PH
01-01-0166	MTR 3HP 1740RPM 182TC TEFC 3PH
01-01-0175	MTR 3HP 1800 RPM 182TC TEFC 575V

LPV SEED TREATER

LPV TREATER WITH SMW TOP ASSEMBLY

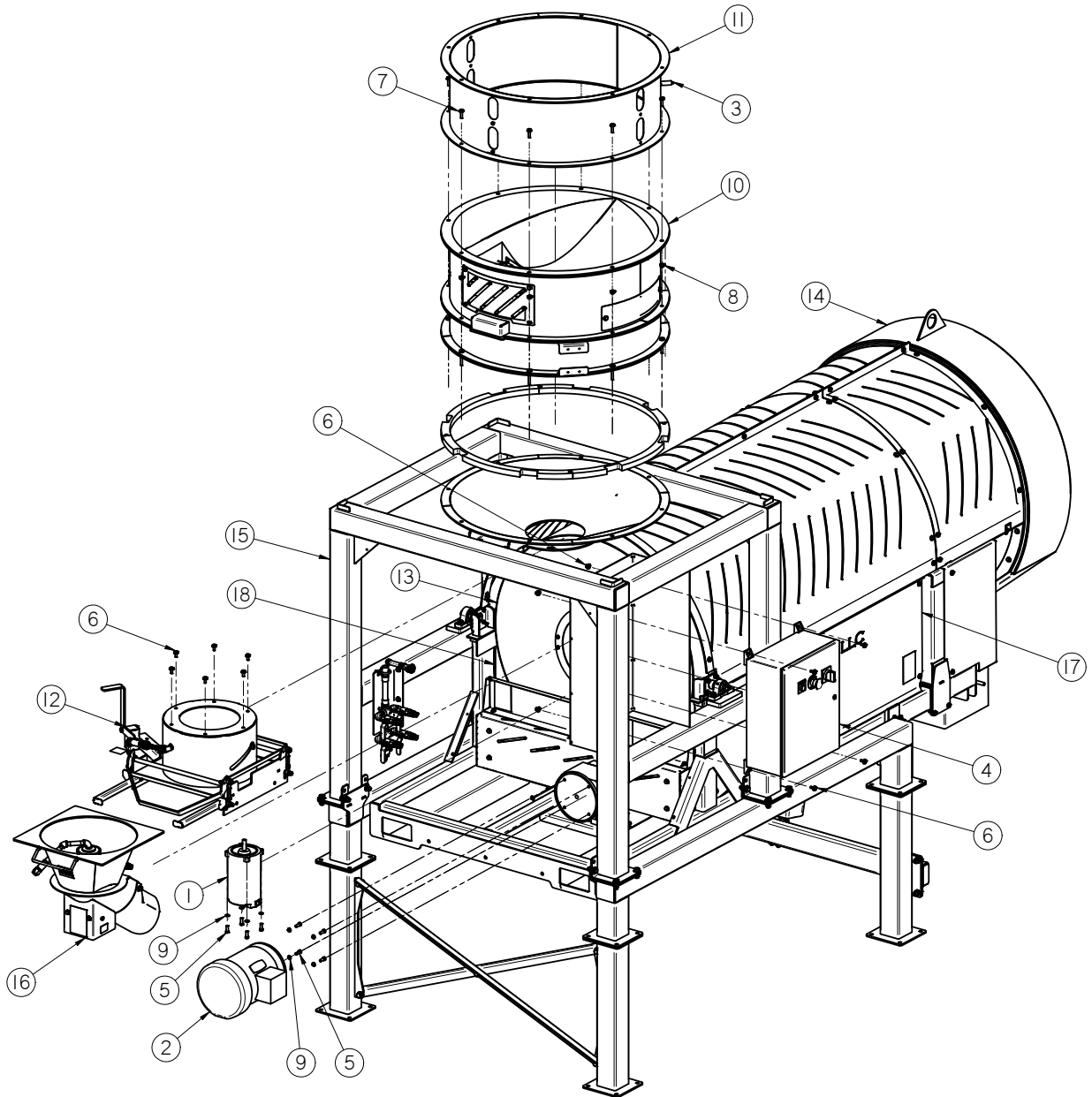

TABLE 1

Part #	Description
01-01-0105	MTR .33HP 1725RPM 56C 3PH TENV
01-01-0144	MTR .50 HP 1725 RPM 56C 575V TENV

TABLE 2

Part #	Description
01-01-0166	MTR 3HP 1740RPM 182TC TEFC 3PH
01-01-0175	MTR 3HP 1800 RPM 182TC TEFC 575V

LPV SEED TREATER

LPV TREATER WITH SMW TOP ASSEMBLY

Item #	Part #	Description	Qty
1	SEE TABLE 1	ATOMIZER MOTOR	1
2	SEE TABLE 2	DRUM MOTOR	1
3	03-10-0147	SENS PROX 24VDC AB QC 875CPN8NP18P3	1
4	SEE TABLE 3	LPV SMW I/O Panel	1
5	06-01-0016	BOLT .375-16 X 1.00 ZP GR5	8
6	06-01-0124	BOLT FLG .375-16 X .750 ZP GR5	10
7	06-01-0189	BOLT FLG .375-16 X 1.250 ZP GR5	8
8	06-03-0014	NUT LOCK FLG .375-16 ZP GR5	12
9	06-04-0003	WSHR LOCK SPLT .375 ZP	8
10	SEE TABLE 4	ASSY SEED METER WHL LPV UL	1
11	SEE TABLE 5	ASSY INLET EXTENSION HOPPER	1
12	18-01-0062	ASSY ADJ CHMBR LPX2000 CS	1
13	18-01-0257	ASSY DRUM LPV 8FT CS	1
14	18-01-0270	ASSY END CHUTE LPV2000	1
15	18-01-0314	ASSY LPV COMMON BASE	1
16	18-01-0318	ASSY ATMZR LPV SS	1
17	18-01-0322	ASSY GRD DRUM LPV RT 8FT GALV	1
18	18-01-0325	ASSY GRD DRUM LPV LT 8FT GALV	1

TABLE 3

Part #	Description
03-12-0381	PNL CNTL LPV TRTR HOPP I/O 120V
03-12-0382	PNL CNTL LPV TRTR SMW I/O 120V

TABLE 4

Part #	Description
13-04-0201	ASSY SEED METER WHL LPX /LPV 2000
13-04-0222	ASSY SEED METER WHL LPX /LPV 2000 575V
13-04-0226	ASSY SEED METER WHL LPX /LPV 300
13-04-0227	ASSY SEED METER WHL LPX /LPV 300 575V

TABLE 5

Part #	Description
13-04-0043	INLET EXTENSION HOPPER - 12 INCH
13-04-0121	INLET EXTENSION HOPPER - 6 INCH

LPV SEED TREATER

LPV SEED WHEEL ASSEMBLY (13-04-0201)

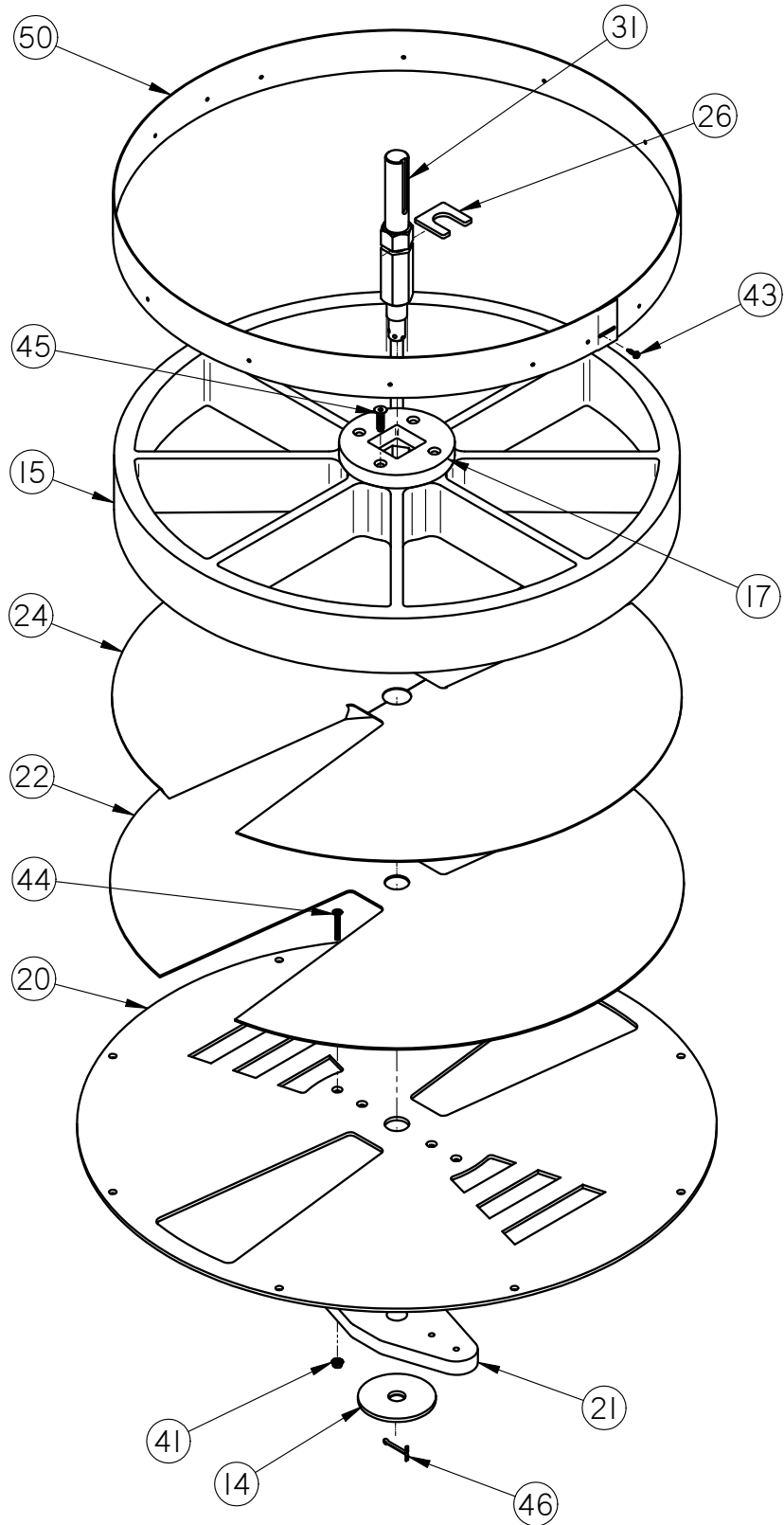

LPV SEED TREATER
LPV SEED WHEEL ASSEMBLY (13-04-0201)

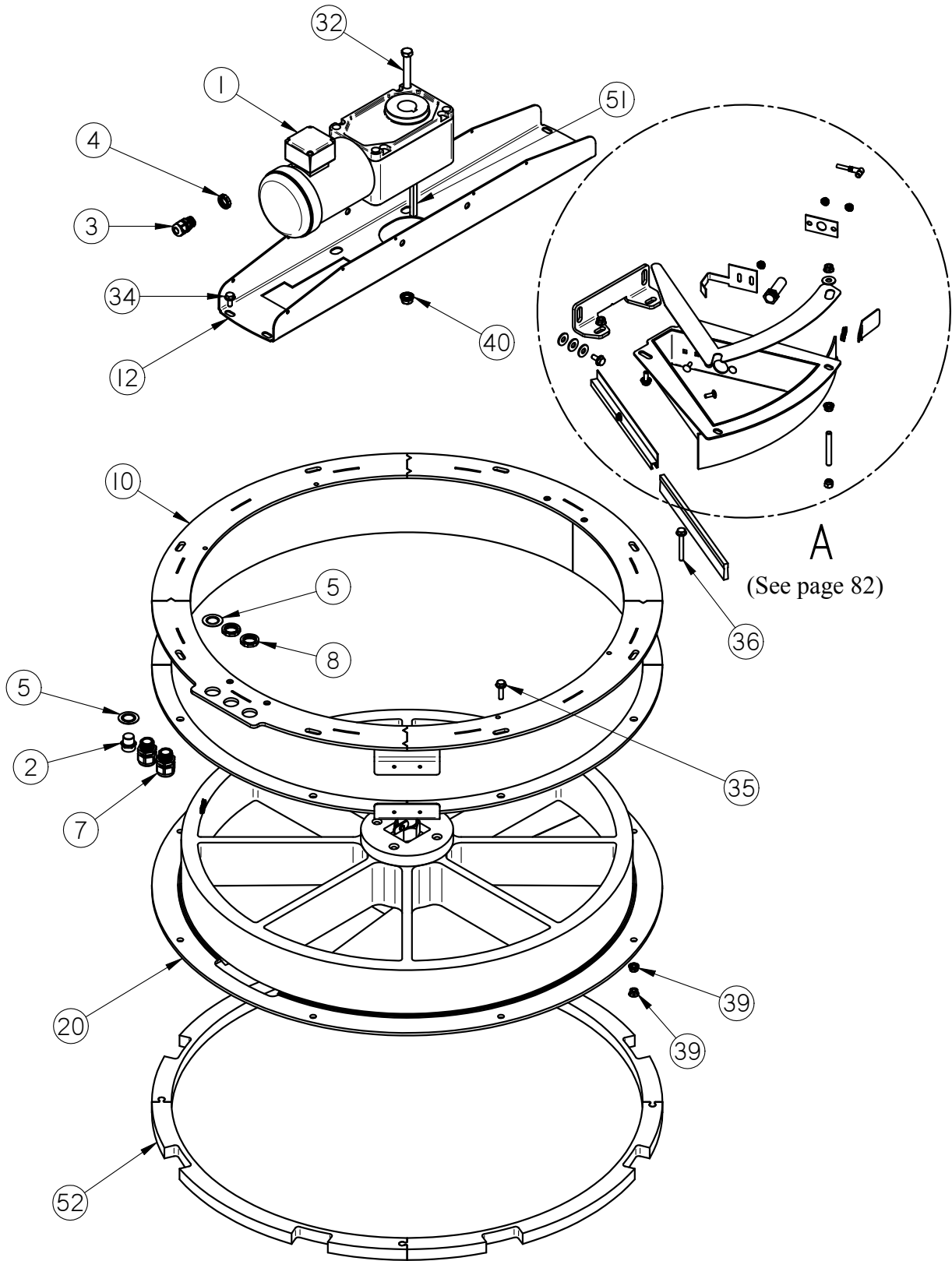

LPV SEED TREATER
LPV SEED WHEEL ASSEMBLY (13-04-0201)

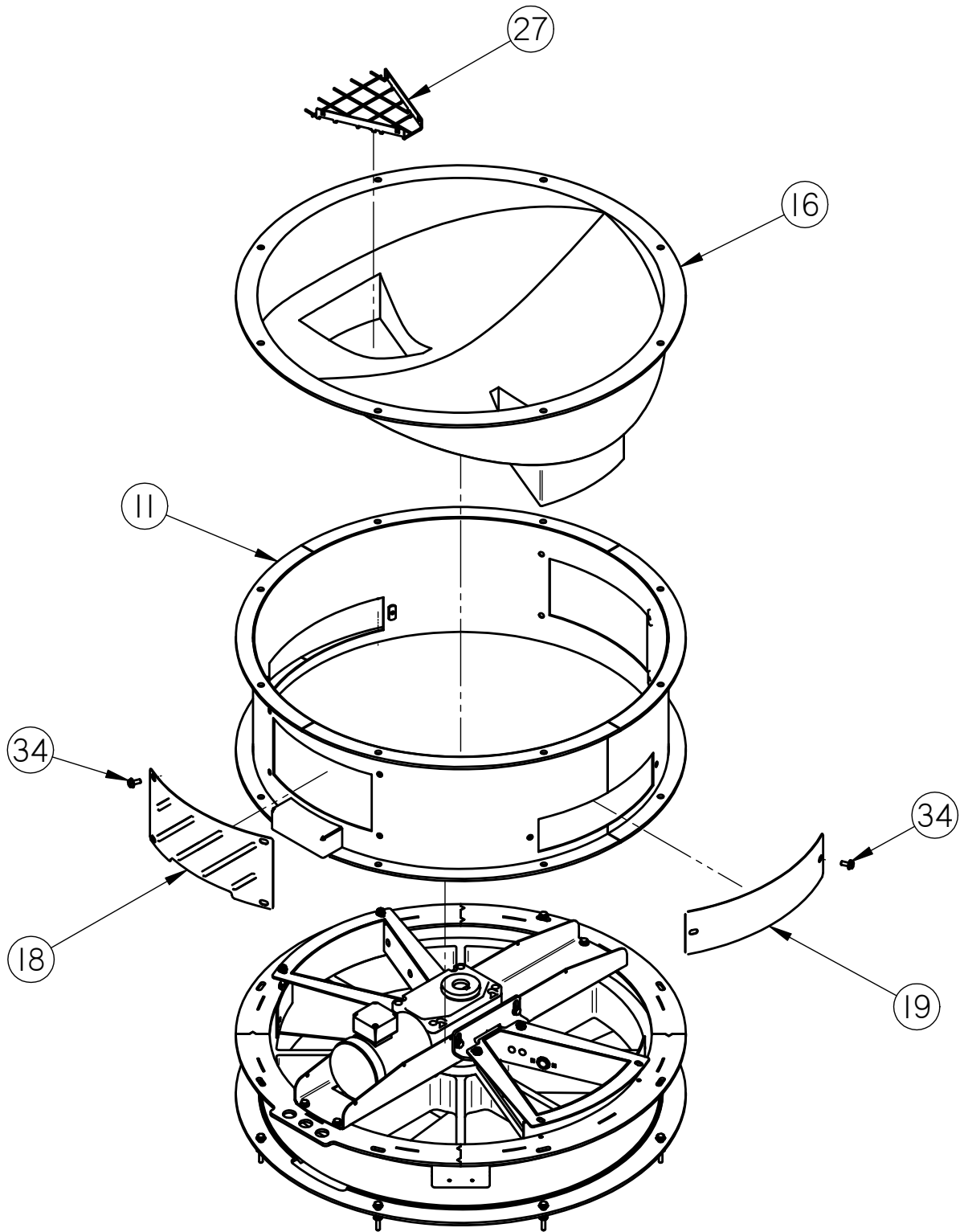

LPV SEED TREATER
LPV SEED WHEEL ASSEMBLY (13-04-0201)

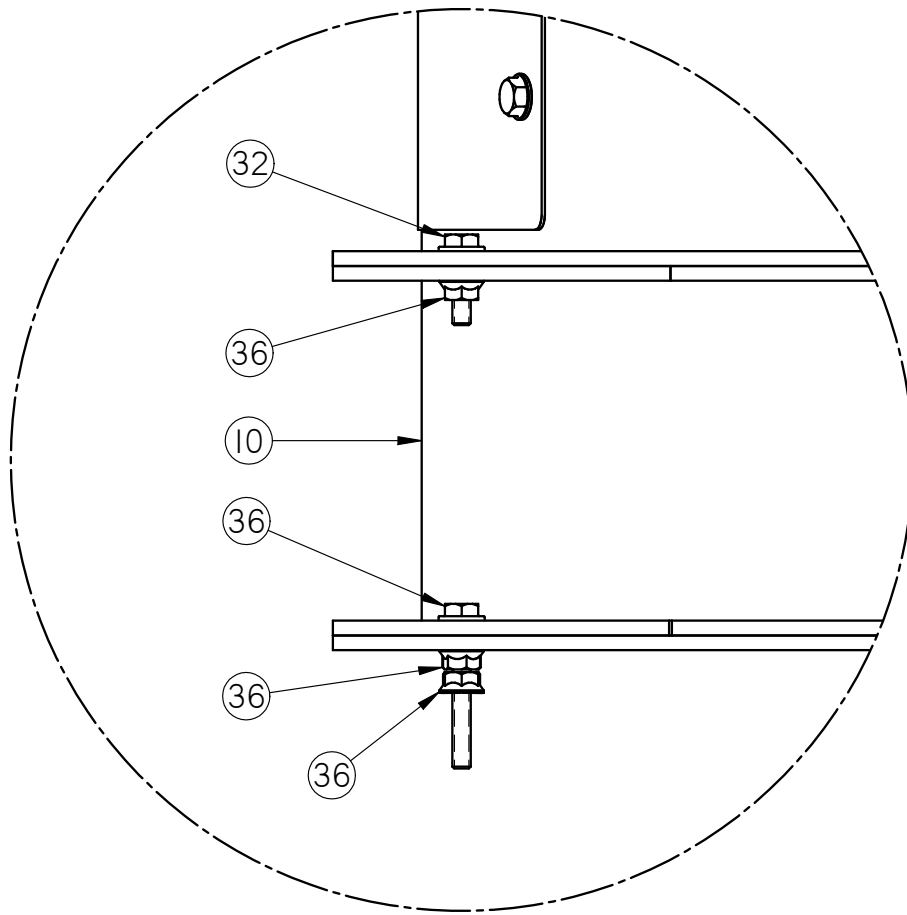
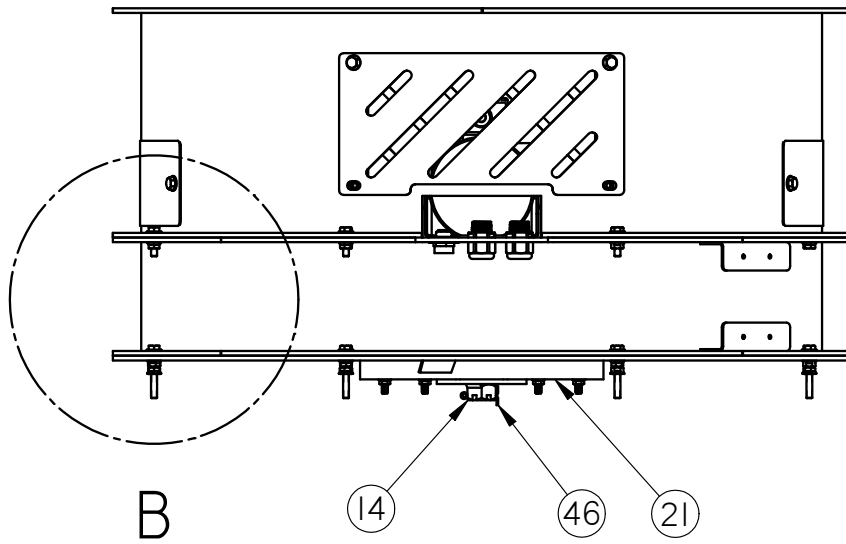

DETAIL B

LPV SEED TREATER

LPV SEED WHEEL ASSEMBLY (13-04-0201)

Item #	Part #	Description	Qty
1	01-01-0229	GMTR RA .50 HP 11RPM 3PH HLLW SHAFT	1
2	03-06-0111	RECP TURCK RSF 44-1/M20/S717/S4000	1
3	03-08-0299	CONN CG 0.5NPT .170-.450 3232LTF	1
4	03-08-0308	NUT NYLOC .500 NPT 8464	1
5	03-08-0348	WSHR RDCG CNDT .75 X .5	2
6	03-08-0355	CONN TRCK PKW 3M-5-RS 4/S760/S771	2
7	03-08-0356	CONN CG .75 NPT M3234GBJ LTCG	2
8	03-08-0357	NUT NYLON.75 NPT 8465	2
9	03-10-0147	SENS PROX 24VDC AB QC 875CPN8NP18P3	2
10	05-03-0164	WDMT SEED METER BODY EXTEN	1
11	05-03-0169	WDMT SEED METER EXTENSION	1
12	05-03-0232	WDMT SMW UPPER BRG BRKT	1
13	05-03-0240	WDMT SMW BRSH PCKT	2
14	05-04-0049	WDMT SEED WHEEL SHAFT NUT	1
15	05-07-0196	MOLDED SEED WHEEL INSERT	1
16	05-07-0197	HPPR SMW DUAL DSCHG ROTO-MLDD	1
17	05-07-0203	MOLDED SEED WHEEL INSERT TOP	1
18	05-10-0890	CVR #1 SEED METER	2
19	05-10-0891	CVR #2 SEED METER	2
20	05-10-0893	PLATE SUPPORT SEED METER STEEL	1
21	05-10-1213	SUPP BTM BRG UHMW SEED METER	1
22	05-10-1306	PAD SEED WHL FOAM RBBR FLOATING	1
23	05-10-1392	BRKT SMW BRSH PCKT HLDR	2
24	05-10-1426	14GA WEAR SPLATE HALF	2
25	05-10-1449	PLT SMW CTR HUB WIPER	2
26	05-10-1588	PLT SHAFT CLIP SMW	1
27	05-10-1872	GRD SMW INLET HOPP PCKT	2
28	05-10-2166	CVR TEST	2
29	05-10-3316	SMW PROX SW HOLDER	2
30	05-10-4192	PLT SMW POCKET SCRAPER	2
31	05-11-0075	DRIVE SHAFT 1.4375 SHAFT	1
32	06-01-0106	BOLT .500-13 X 5.50 ZP GR5	1
33	06-01-0122	BOLT, CARRIAGE, .250-20x.75 G5 ZP	18
34	06-01-0124	BOLT FLG .375-16 X .750 ZP GR5	18
35	06-01-0189	BOLT FLG .375-16 X 1.250 ZP GR5	1

LPV SEED TREATER

LPV SEED WHEEL ASSEMBLY (13-04-0201)

Item #	Part #	Description	Qty
36	06-01-0204	BOLT FLG .375-16 X 2.50 ZP GR5 FTH	8
37	06-03-0003	NUT NYL LOCK .375-16 ZP GR5	3
38	06-03-0013	NUT,LOCK, FLG .250-20 ZP SERRATTED	26
39	06-03-0014	NUT LOCK FLG .375-16 ZP GR5	12
40	06-03-0015	NUT LOCK FLG .500-13 ZP GR5	1
41	06-03-0019	NUT LOCK FLG .3125-18 ZP GR5	1
42	06-05-0004	WSHR FLAT .375 ZP	10
43	06-06-0023	SCRW, SELF TAPPING, 10-16 ZP X .750	14
44	06-06-0046	SCRW .313-18 X 2.0 ZP FLAT HD PHLP	1
45	06-06-0070	SCRW MACH .375-16 X 1.50 SH FLHD BO	1
46	06-09-0023	PIN CTTR .188 X 2.00 ZP	1
47	06-10-0019	SEAL BRSH 12.75 OAL 1IN EXP LG	2
48	06-14-0013	STUD .375-16 ZP X 3 IN LG ZP	3
49	100118	HOLDER BRUSH SMW	2
50	101BC9	PSM SMW GALV RING	1
51	11-13-0004	KEYSTOCK 3/8 X 3/8 CS	1
52	13-04-0058	KIT SMW SCL CALB	1

LPV SEED TREATER
LPV300 SEED WHEEL ASSEMBLY (13-04-0226)

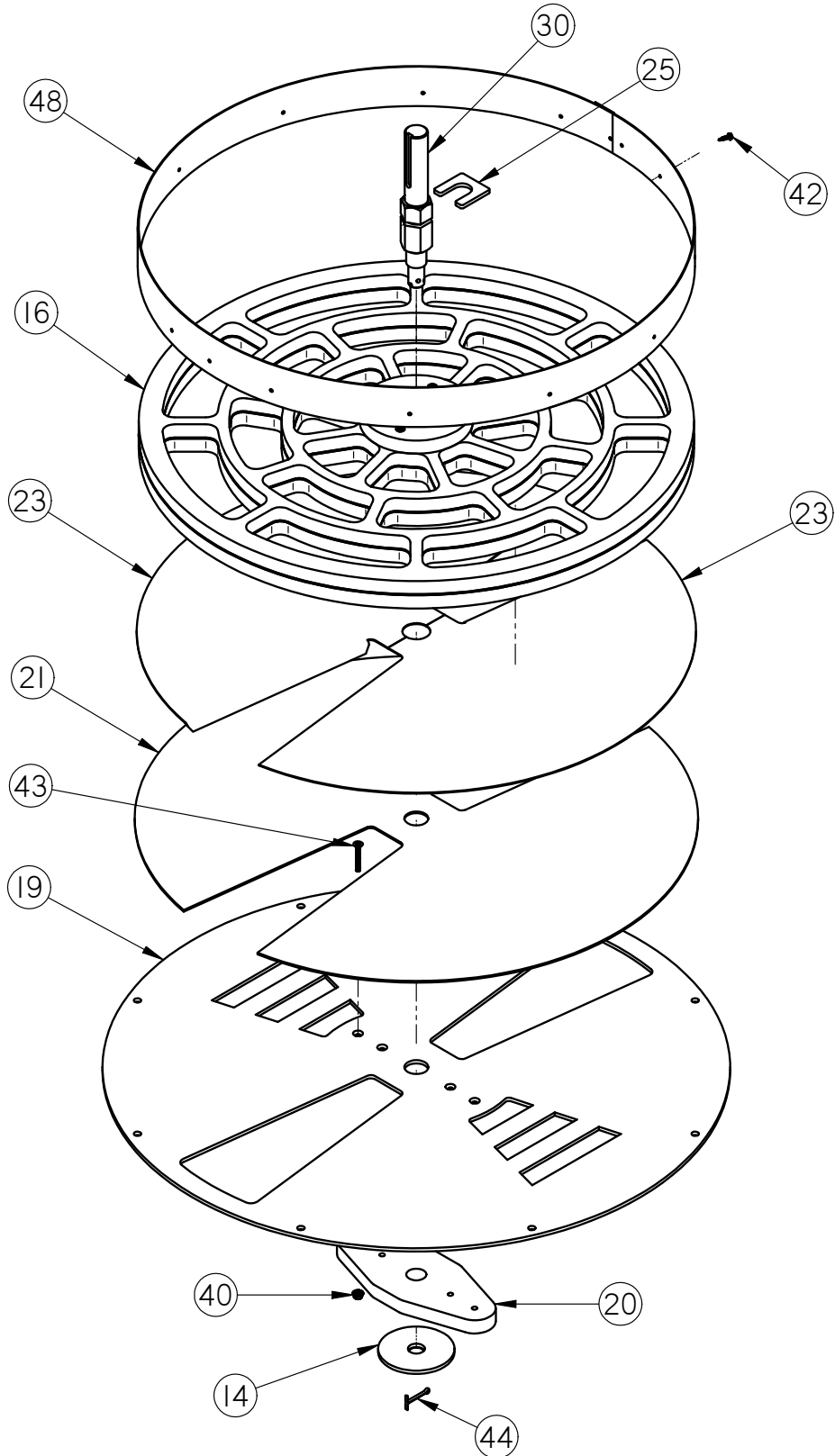

LPV SEED TREATER
LPV300 SEED WHEEL ASSEMBLY (13-04-0226)

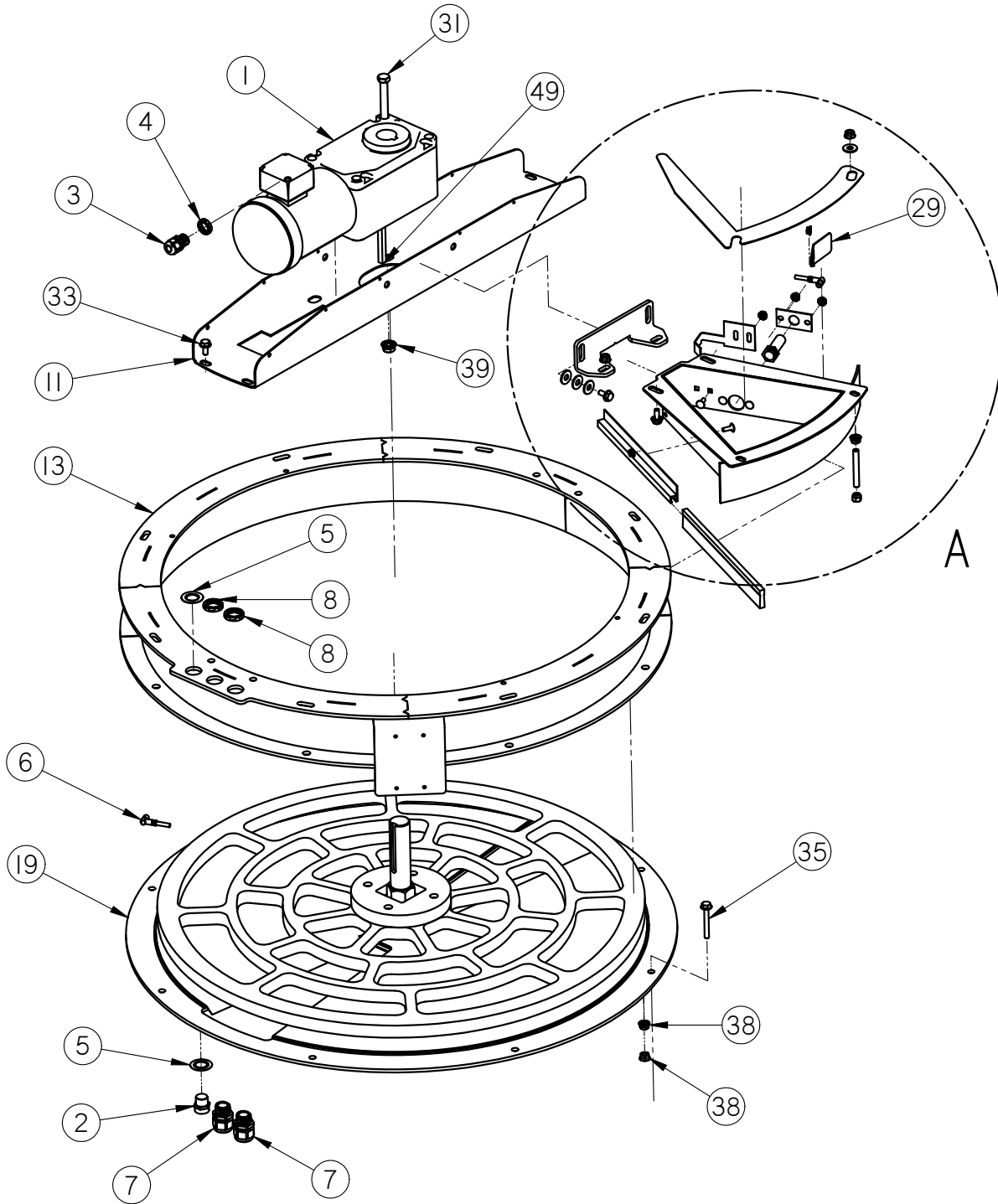

LPV300 SEED WHEEL ASSEMBLY (13-04-0226)

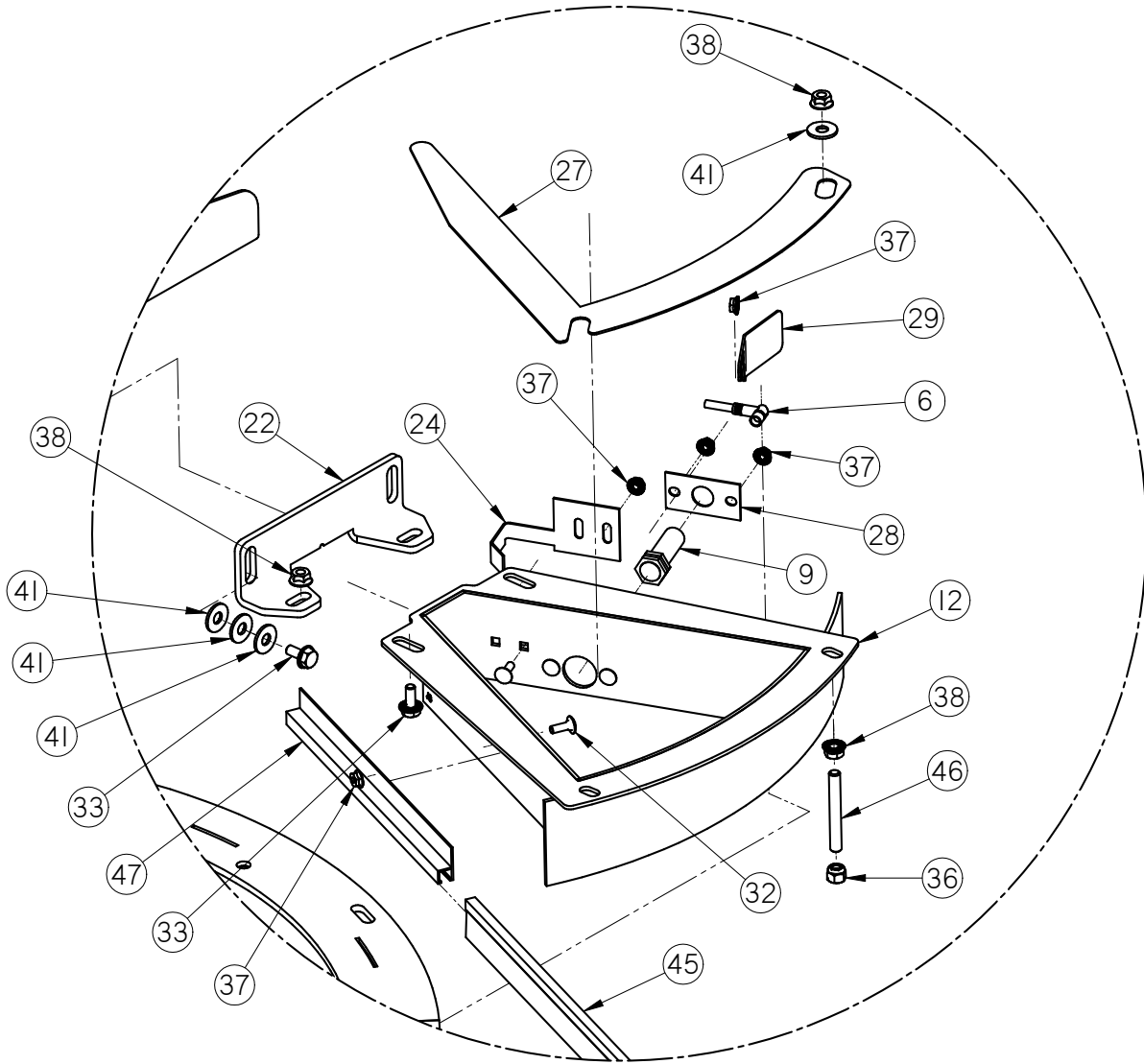

DETAIL A

LPV SEED TREATER
LPV300 SEED WHEEL ASSEMBLY (13-04-0226)

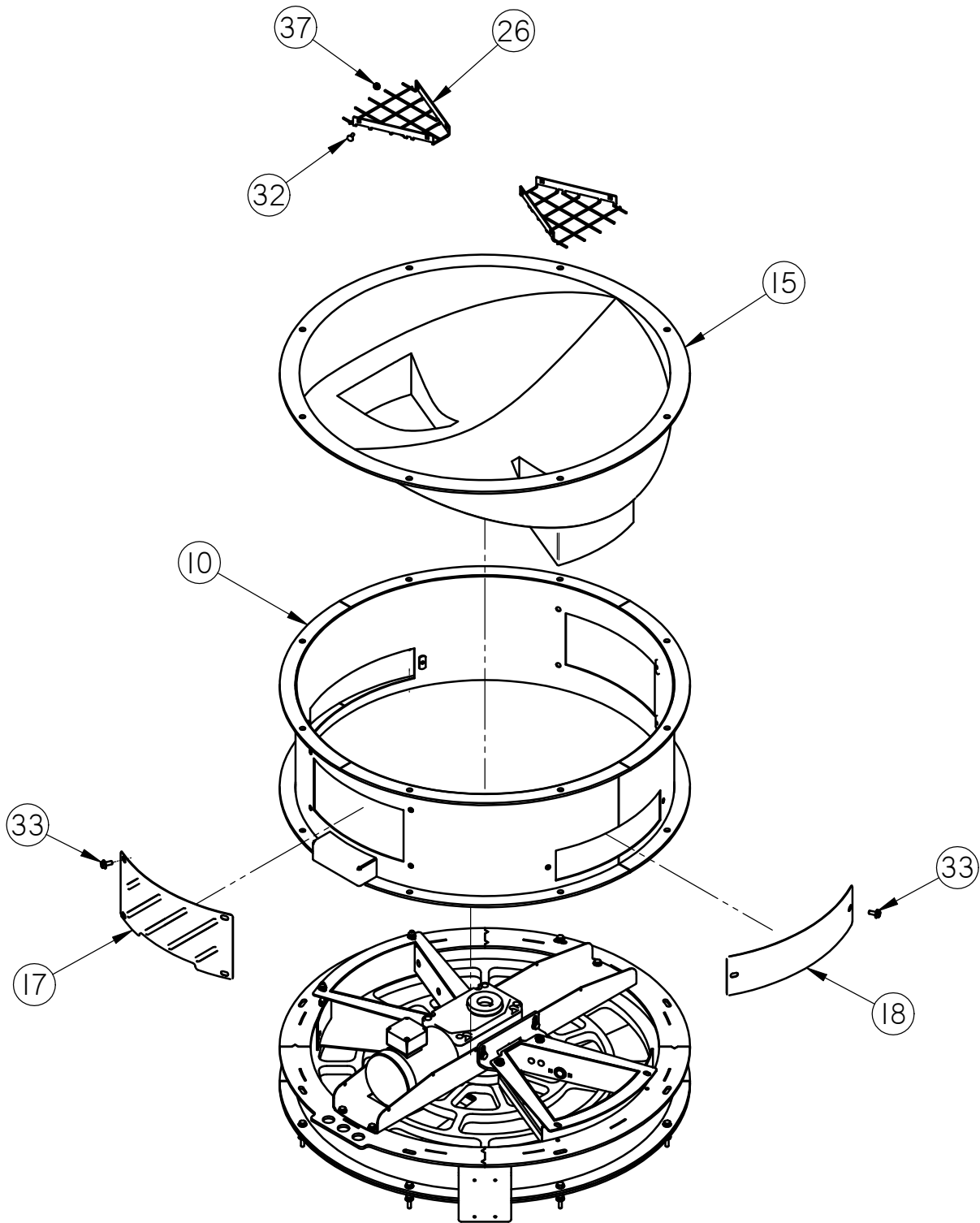

LPV SEED TREATER
LPV300 SEED WHEEL ASSEMBLY (13-04-0226)

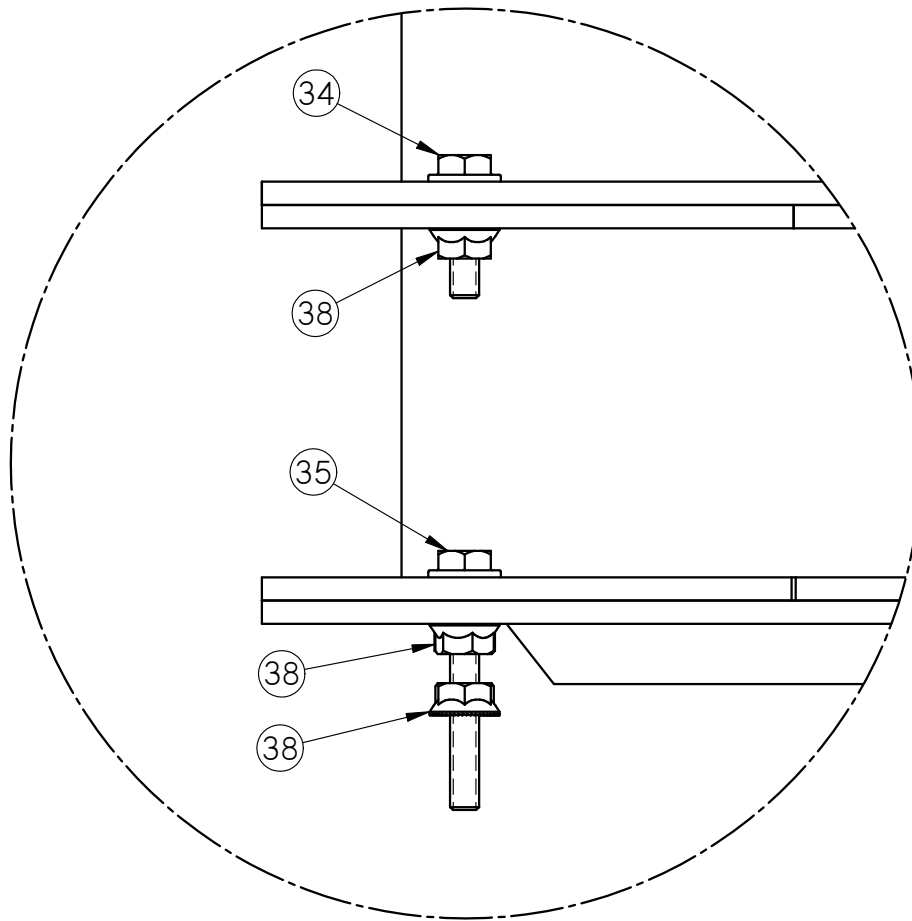
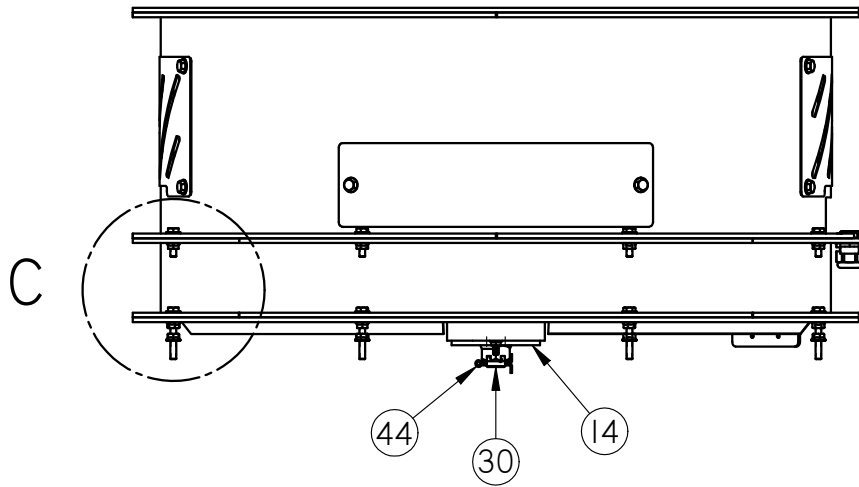

DETAIL C

LPV SEED TREATER

LPV300 SEED WHEEL ASSEMBLY (13-04-0226)

Item #	Part #	Description	Qty
1	01-01-0229	GMTR RA .50 HP 11RPM 3PH HLLW SHAFT	1
2	03-06-0111	RECP TURCK RSF 44-1/M20/S717/S4000	1
3	03-08-0299	CONN CG 0.5NPT .170-.450 3232LTF	1
4	03-08-0308	NUT NYLOC .500 NPT 8464	1
5	03-08-0348	WSHR RDCG CNDT .75 X .5	2
6	03-08-0355	CONN TRCK PKW 3M-5-RS 4/S760/S771	2
7	03-08-0356	CONN CG .75 NPT M3234GBJ LTCG	2
8	03-08-0357	NUT NYLON.75 NPT 8465	2
9	03-10-0147	SENS PROX 24VDC AB QC 875CPN8NP18P3	2
10	05-03-0169	WDMT SEED METER EXTENSION	1
11	05-03-0232	WDMT SMW UPPER BRG BRKT	1
12	05-03-0240	WDMT SMW BRSH PCKT	2
13	05-03-0608	WDMT SEED METER BODY EXTEN	1
14	05-04-0049	WDMT SEED WHEEL SHAFT NUT	1
15	05-07-0197	HPPR SMW DUAL DSCHG ROTO-MLDD	1
16	05-07-0590	ASSY SMW 1.75 HEX DRV 2IN TALL	1
17	05-10-0890	CVR #1 SEED METER	2
18	05-10-0891	CVR #2 SEED METER	2
19	05-10-0893	PLATE SUPPORT SEED METER STEEL	1
20	05-10-1213	SUPP BTM BRG UHMW SEED METER	1
21	05-10-1306	PAD SEED WHL FOAM RBBR FLOATING	1
22	05-10-1392	BRKT SMW BRSH PCKT HLDR	2
23	05-10-1426	14GA WEAR SPLATE HALF	2
24	05-10-1449	PLT SMW CTR HUB WIPER	2
25	05-10-1588	PLT SHAFT CLIP SMW	1
26	05-10-1872	GRD SMW INLET HOPP PCKT	2
27	05-10-2166	CVR TEST	2
28	05-10-3316	SMW PROX SW HOLDER	2
29	05-10-4192	PLT SMW POCKET SCRAPER	2
30	05-11-0224	DRIVE SHAFT 1.4375 SHAFT	1
31	06-01-0106	BOLT .500-13 X 5.50 ZP GR5	4
32	06-01-0122	BOLT, CARRIAGE, .250-20x.75 G5 ZP	18
33	06-01-0124	BOLT FLG .375-16 X .750 ZP GR5	24
34	06-01-0189	BOLT FLG .375-16 X 1.250 ZP GR5	8
35	06-01-0204	BOLT FLG .375-16 X 2.50 ZP GR5 FTH	8

LPV SEED TREATER

LPV300 SEED WHEEL ASSEMBLY (13-04-0226)

Item #	Part #	Description	Qty
36	06-03-0003	NUT NYL LOCK .375-16 ZP GR5	3
37	06-03-0013	NUT,LOCK, FLG .250-20 ZP SERRATTED	26
38	06-03-0014	NUT LOCK FLG .375-16 ZP GR5	37
39	06-03-0015	NUT LOCK FLG .500-13 ZP GR5	4
40	06-03-0019	NUT LOCK FLG .3125-18 ZP GR5	4
41	06-05-0004	WSHR FLAT .375 ZP	10
42	06-06-0023	SCRW, SELF TAPPING, 10-16 ZP X .750	14
43	06-06-0046	SCRW .313-18 X 2.0 ZP FLAT HD PHLP	4
44	06-09-0023	PIN CTTR .188 X 2.00 ZP	1
45	06-10-0019	SEAL BRSH 12.75 OAL 1IN EXP LG	2
46	06-14-0013	STUD .375-16 ZP X 3 IN LG ZP	4
47	100118	HOLDER BRUSH SMW	2
48	101BC9	PSM SMW GALV RING	1
49	11-13-0004	KEYSTOCK 3/8 X 3/8 CS	1
50	13-04-0058	KIT SMW SCL CALB	1

LPV SEED TREATER
Seed Wheel Scale Kit (13-04-0058)

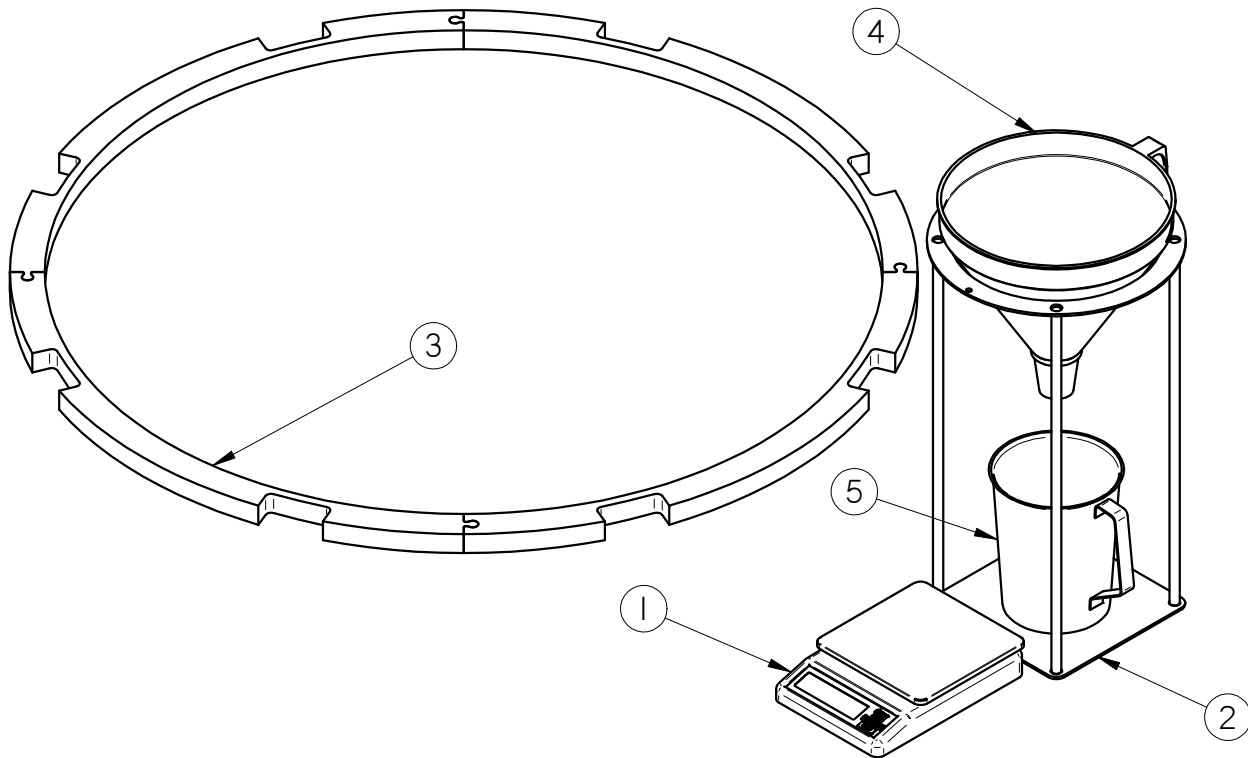

Item #	Part #	Description	Qty
1	03-19-0051	SCALE, CARDINAL 6.89 X 6.5 11 LBS	1
2	05-03-0248	WDMT CAL CUP FILL FR	1
3	05-10-2463	SEAL BETWEEN FLANGES SMW TO TRTR	4
4	05-11-0123	FUNNEL SMW CALB CUP FILL	1
5	07-02-0008	CUP MEASURE 64OZ SS GRADUATED	1

LPV SEED TREATER

DRUM & ATOMIZER 3HP MOTOR KIT (03-20-0101)

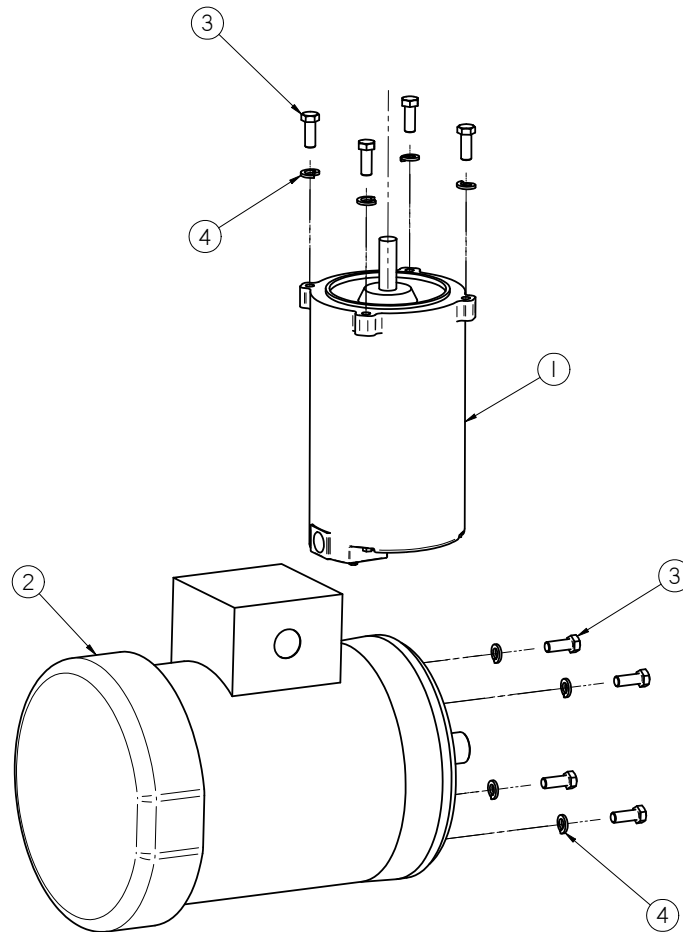

Item #	Part #	Description	Qty
1	01-01-0105	MTR .33HP 1725RPM 56C 3PH TENV	1
2	01-01-0166	MTR 3HP 1740RPM 182TC TEFC 3PH	1
3	06-01-0016	BOLT .375-16 X 1.00 ZP GR5	8
4	06-04-0003	WSHR LOCK SPLT .375 ZP	8

NOTICE The following parts are in the motor kit but do not appear in the drawing view

Item #	Part #	Description	Qty
5	03-06-0101	PLUG TURCK RSF 44-0.5M/NPT	1
6	03-08-0022	CNDT .500 FTTG HUB CONN	1
7	03-08-0283	CONN TURCK RSM 44-2M/S4000	1
8	03-08-0299	CONN CG 0.5 NPT .170-.450 3232LTF	1

OPTIONAL REMOTE HMI PANEL ASSEMBLY (03-12-0340)

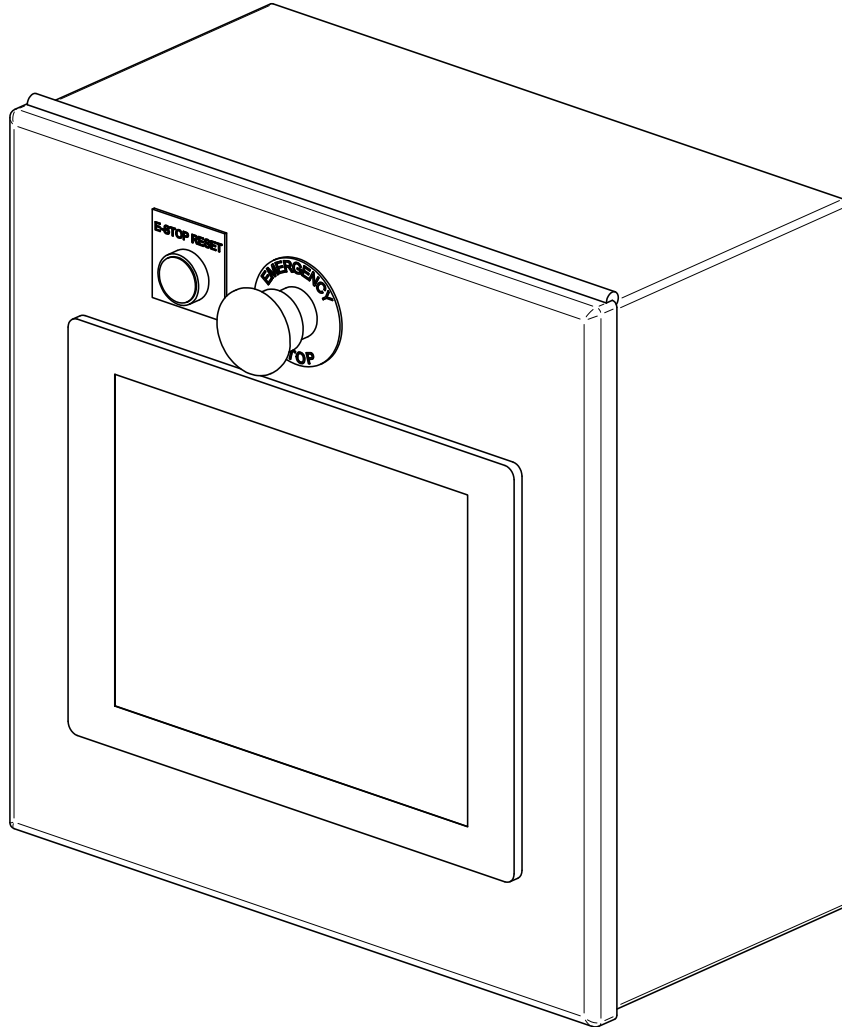

There is an optional remote LPV Automated Treater Control Panel. It allows the operator to run the treater from up to 25 feet away. If it is ordered with the treater, it will come with the HMI operation screen already installed. If it is added later as an upgrade, the HMI will be removed from the original Control Panel and installed in the remote panel. A plug is included in the kit to plug the hole in the main panel after the HMI is removed. The remote panel comes with a 10 foot power cord.

LPV SEED TREATER

ADJUSTABLE STAND - MAIN CONTROL PANEL ASSEMBLY (05-03-1471)

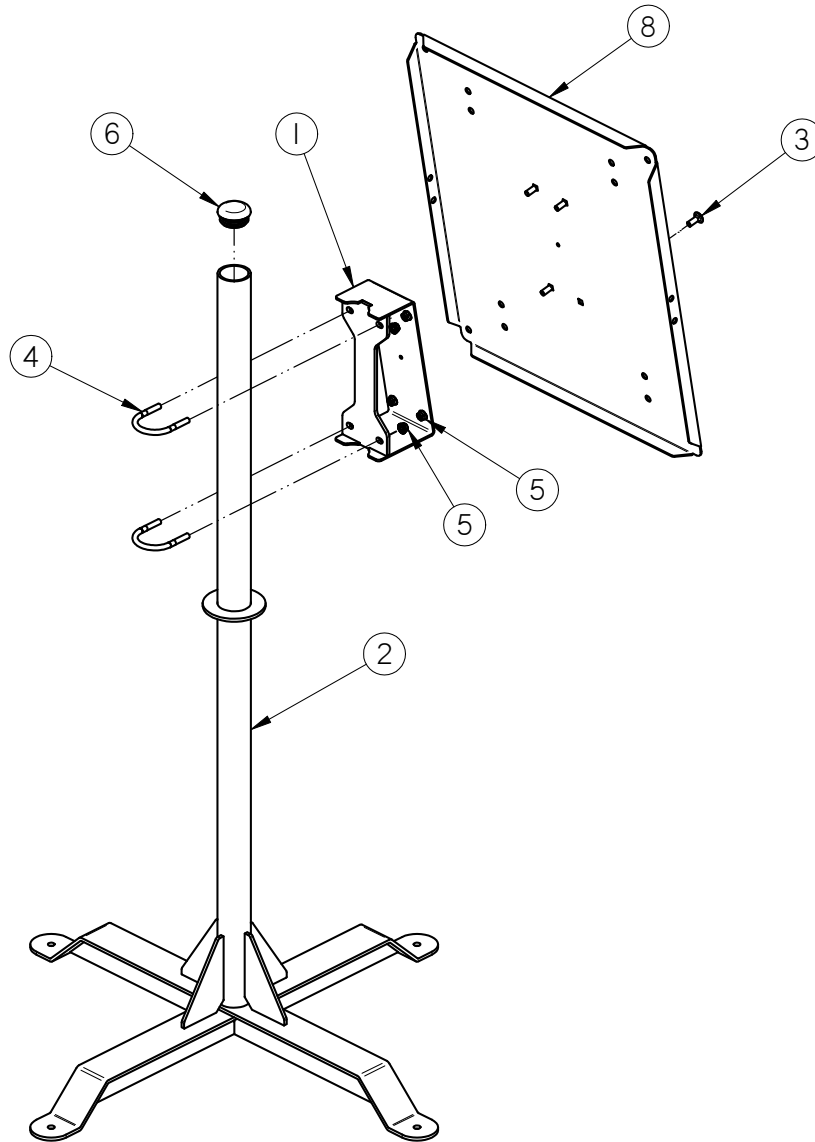

Item #	Part #	Description	Qty
1	05-03-1479	WDMT PNL ADJ	1
2	05-03-1545	WDMT PANEL STAND	1
3	06-01-0153	BOLT CRG .375-16X.750 ZP SHORT NECK	4
4	06-01-0287	BOLT U .375-16 X 2.50 X 3.125 ZP	2
5	06-03-0014	NUT LOCK FLG .375-16 ZP GR5	7
6	06-10-0056	PLUG TBG RD RIB POLY 2.38 X .156W	1
7	103651	PLT PNL MT	1

LPV SEED TREATER

MAIN CONTROL PANEL ASSEMBLY (13-12-0118)

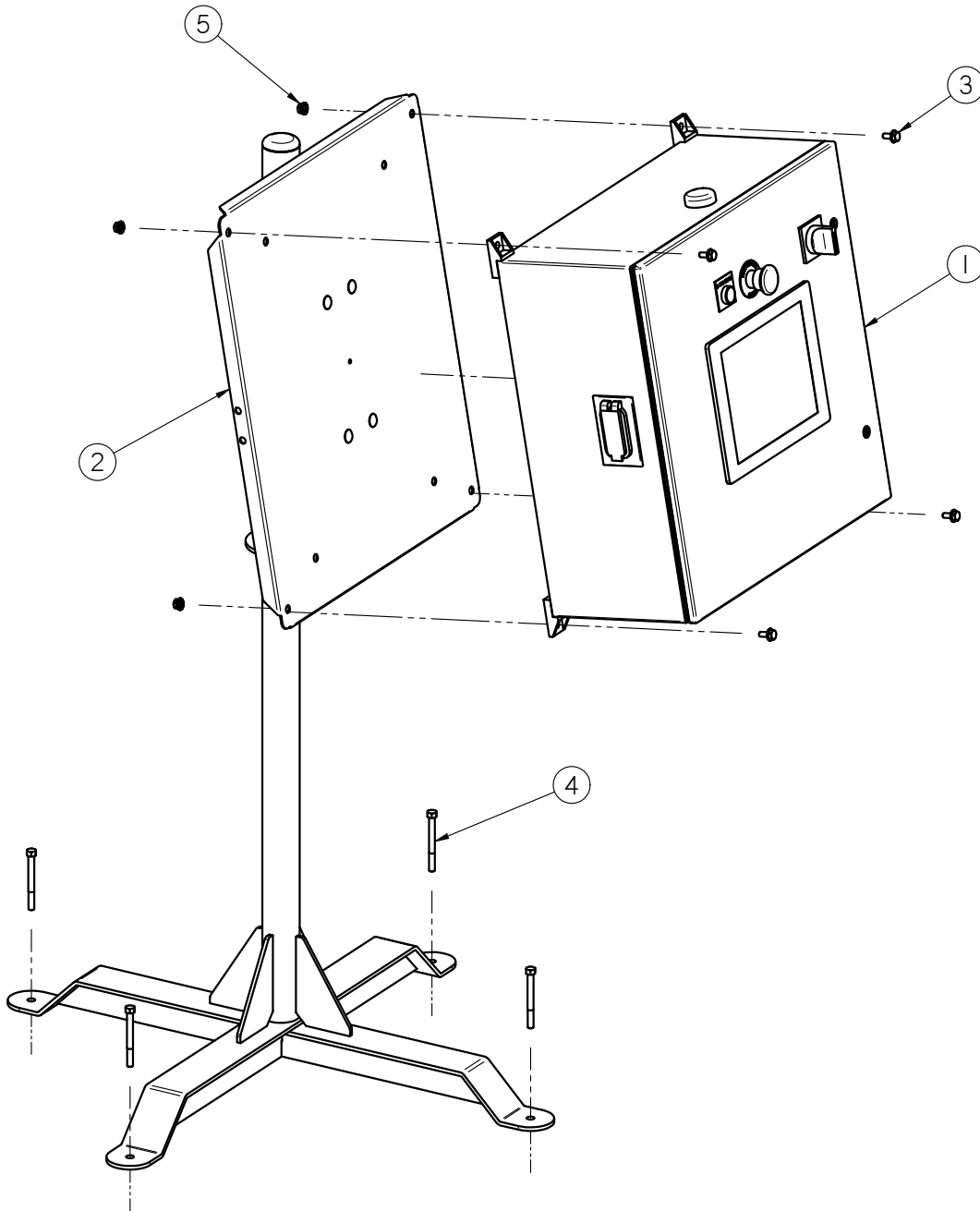

Item #	Part #	Description	Qty
1	03-12-0366	MAIN CONTROL PANEL U-TREAT	1
2	05-03-1471	ASSY PNL FRM 4PUMP SAP	1
3	06-01-0124	BOLT, FLG .375-16 UNC ZP GRADE 5; 3/4" LG	4
4	06-01-0220	BOLT .375-16 X 3.75 CONCRETE ZP	4
5	06-03-0033	NUT LOCK FLG .375-16 GR8	4

LPV SEED TREATER

C2D2 COMPLIANT MAIN CONTROL PANEL ASSEMBLY (13-12-0119)

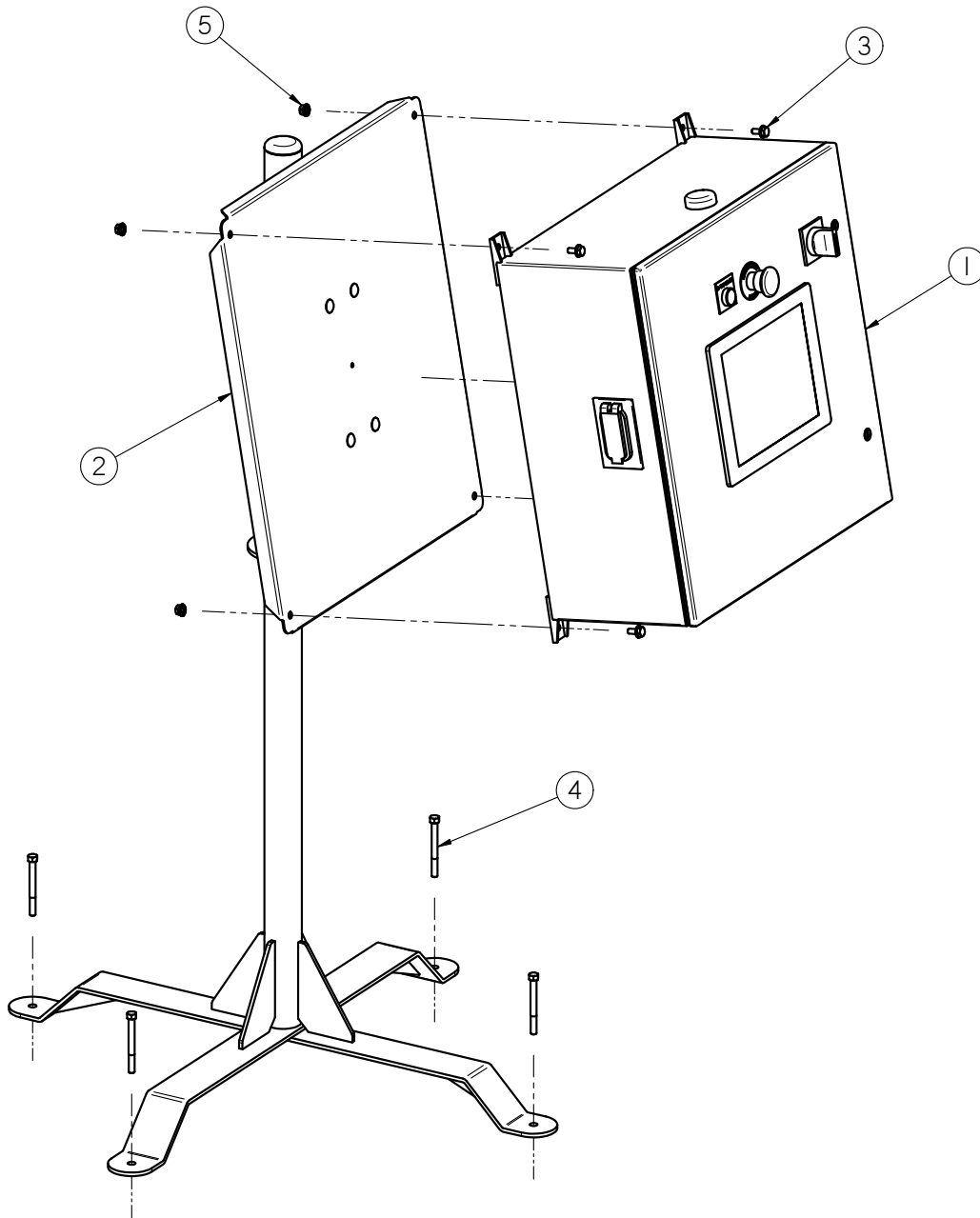

Item #	Part #	Description	Qty
1	03-12-0367	MAIN CONTROL PANEL U-TREAT	1
2	05-03-1471	ASSY PNL FRM 4PUMP SAP	1
3	06-01-0124	BOLT, FLG .375-16 UNC ZP GRADE 5; 3/4" LG	4
4	06-01-0220	BOLT .375-16 X 3.75 CONCRETE ZP	4
5	06-03-0033	NUT LOCK FLG .375-16 GR8	4

LPV SEED TREATER

ADJUSTABLE STAND - MAIN CONTROL PANEL ASSEMBLY (05-03-1658)

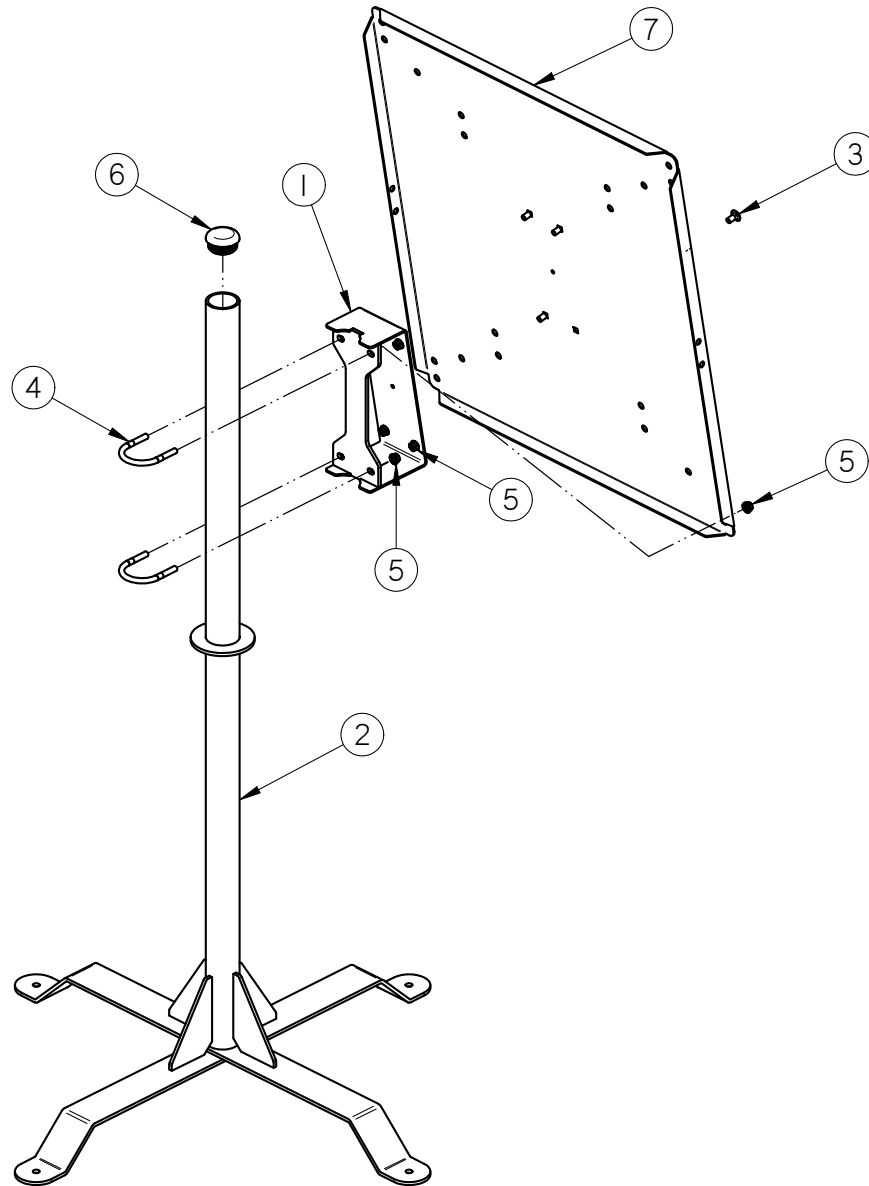

Item #	Part #	Description	Qty
1	05-03-1479	WDMT PNL ADJ	1
2	05-03-1545	WDMT PANEL STAND	1
3	06-01-0153	BOLT CRG .375-16X.750 ZP SHORT NECK	4
4	06-01-0287	BOLT U .375-16 X 2.50 X 3.125 ZP	2
5	06-03-0014	NUT LOCK FLG .375-16 ZP GR5	8
6	06-10-0056	PLUG TBG RD RIB POLY 2.38 X .156W	1
7	104D39	PLT PNL MT	1

LPV SEED TREATER

MAIN CONTROL PANEL WITH 4 PUMP CONTROLLER ASSEMBLY (13-12-0144)

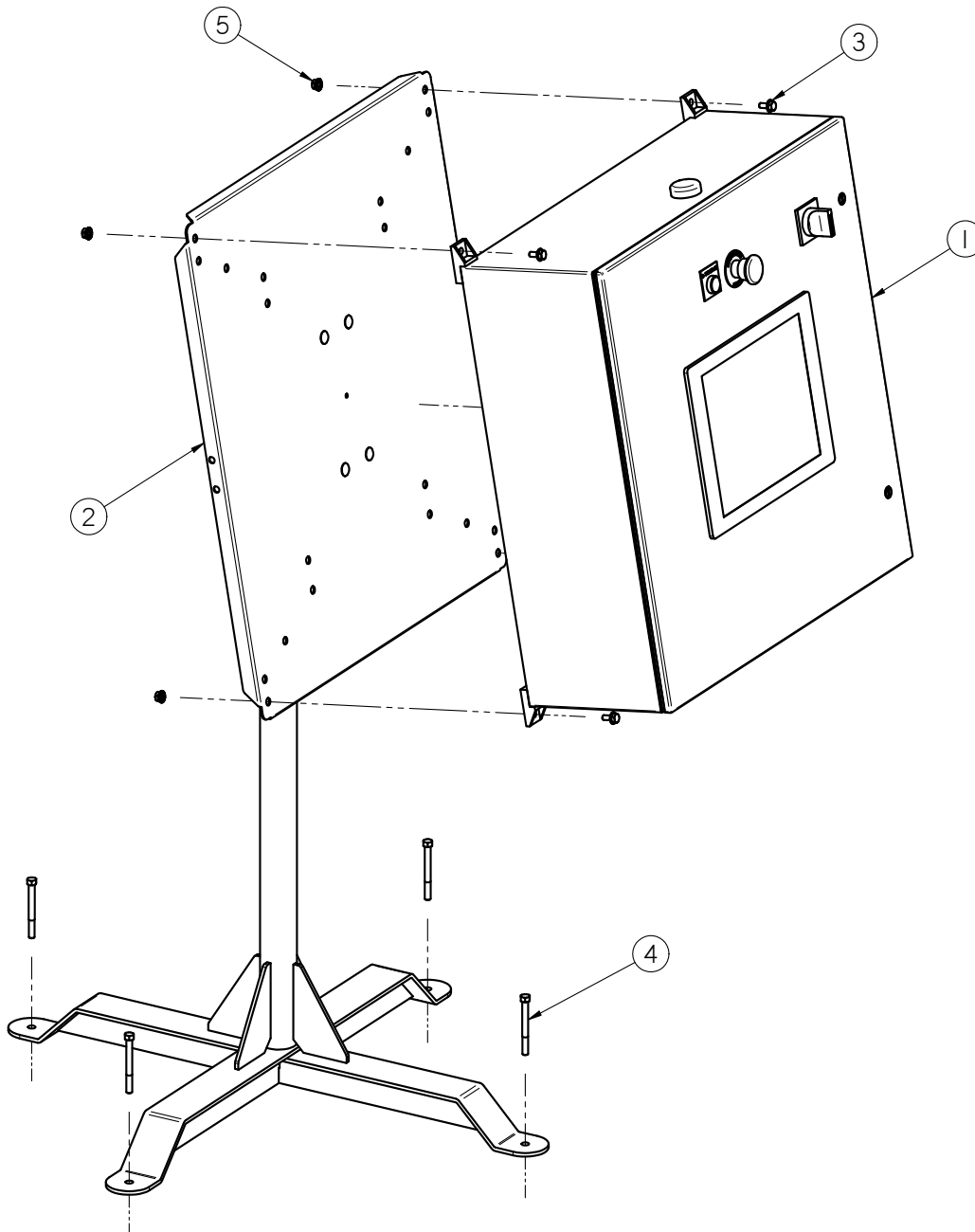

Item #	Part #	Description	Qty
1	03-12-0517	MAIN CONTROL PANEL WITH 4PC 120V	1
2	05-03-1658	ASSY PNL FRM 4PUMP SAP	1
3	06-01-0124	BOLT FLG .375-16 X .750 ZP GR5	4
4	06-01-0220	BOLT 3/8-16 CONC ANCHOR ZP 3.75	4
5	06-03-0014	NUT LOCK FLG .375-16 ZP GR5	4

LPV SEED TREATER

TREATER CONTROL PANEL ASSEMBLY (13-12-0126)

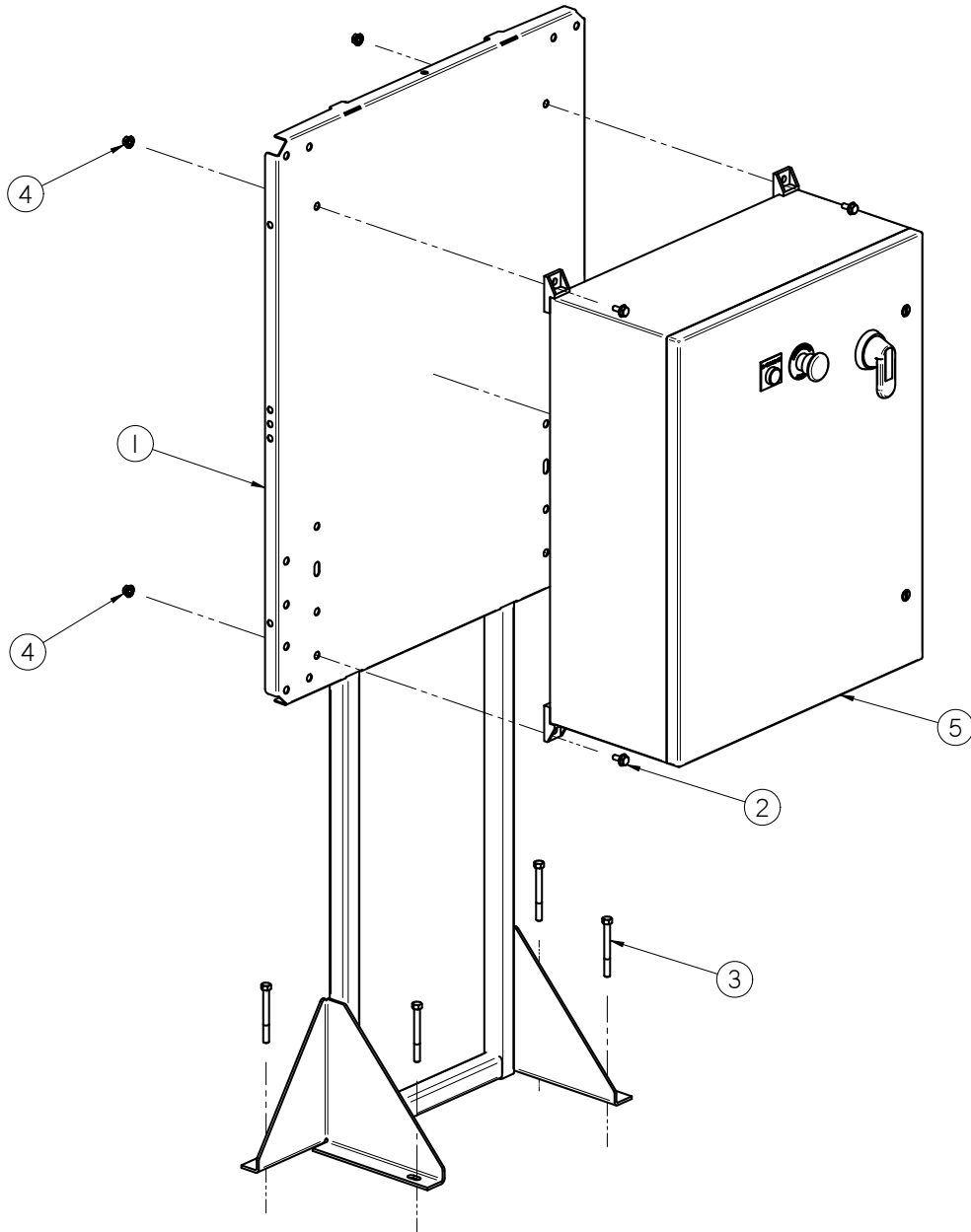

Item #	Part #	Description	Qty
1	05-03-0580	BIN SITE MAIN CNTL PNL STAND	1
2	06-01-0124	BOLT FLG .375-16 X .750 ZP GR5	4
3	06-01-0220	BOLT 3/8-16 CONC ANCHOR ZP 3.75	4
4	06-03-0014	NUT LOCK FLG .375-16 ZP GR5	4
5	SEE TABLE 1	PANEL CONTROL LPV TREATER	1

LPV SEED TREATER

TREATER CONTROL PANEL ASSEMBLY (13-12-0126)

TABLE 1	
Part #	Description
03-12-0491	PNL CNTL LPV TRTR 230V 1PH w/SMW (C2D2)
03-12-0497	PNL CNTL LPV TRTR 230V 1PH w/SMW
03-12-0498	PNL CNTL LPV TRTR 230V 1PH no-SMW
03-12-0499	PNL CNTL LPV TRTR 230V 3PH w/SMW (C2D2)
03-12-0500	PNL CNTL LPV TRTR 230V 3PH no-SMW
03-12-0501	PNL CNTL LPV TRTR 460V 3PH w/SMW (C2D2)
03-12-0502	PNL CNTL LPV TRTR 460V 3PH no-SMW
03-12-0503	PNL CNTL LPV TRTR 575V 3PH w/SMW (C2D2)
03-12-0504	PNL CNTL LPV TRTR 575V 3PH no-SMW
03-12-0505	PNL CNTL LPV TRTR 380V 3PH w/SMW
03-12-0506	PNL CNTL LPV TRTR 380V 3PH no-SMW

LPV SEED TREATER

NOTES:

USC LIMITED WARRANTY**SECTION
J**

USC, LLC, (Manufacturer) warrants its seed treating equipment as follows:

1. **Limited Warranty:** Manufacturer warrants that the Products sold hereunder will be free from defects in material and workmanship for a period of 18 months from date of shipment. If the Products do not conform to this Limited Warranty during the warranty period, Buyer shall notify Manufacturer in writing of the claimed defects and demonstrate to Manufacturer satisfaction that said defects are covered by this Limited Warranty. If the defects are properly reported to Manufacturer within the warranty period, and the defects are of such type and nature as to be covered by this warranty, Manufacturer shall, at its expense, furnish replacement Products or, at Manufacturer's option, replacement parts for the defective products. Shipping and installation of the replacement Products or replacement parts shall be at the Buyer's expense.

2. **Other Limits:** THE FOREGOING IS IN LIEU OF ALL OTHER WARRANTIES, EXPRESSED OR IMPLIED, INCLUDING BUT NOT LIMITED TO THE IMPLIED WARRANTIES OF MERCHANTABILITY AND FITNESS FOR A PARTICULAR PURPOSE. Manufacturer does not warrant against damages or defects arising from improper installation (where installation is by persons other than Manufacturer), against defects in products or components not manufactured by Manufacturer, or against damages resulting from such non-Manufacturer made products or components. Manufacturer passes on to the Buyer the warranty it received (if any) from the maker of such non-Manufacturer made products or components. This warranty also does not apply to Products upon which repairs and / or modifications have been effected or attempted by persons other than pursuant to written authorization by Manufacturer. This includes any welding on equipment which could damage electrical components. Manufacturer does not warrant against casualties or damages resulting from misuse and / or abuse of Products, improper storage or handling, acts of nature, effects of weather, including effects of weather due to outside storage, accidents, or damages incurred during transportation by common carrier.

3. **Exclusive Obligation:** THIS WARRANTY IS EXCLUSIVE. The sole and exclusive obligation of Manufacturer shall be to repair or replace the defective Products in the manner and for the period provided above. Manufacturer shall not have any other obligation with respect to the Products or any part thereof, whether based on contract, tort, strict liability or otherwise. Under no circumstances, whether based on this Limited Warranty or otherwise, shall Manufacturer be liable for lost profits, lost revenue, lost sales (whether direct or indirect damages), incidental, special, punitive, indirect or consequential damages.

4. **Other Statements:** Manufacturer's employees or representatives' oral or other written statements do not constitute warranties, shall not be relied upon by Buyer, and are not a part of the contract for sale or this limited warranty.

5. **Return Policy:** Approval is required prior to returning goods to Manufacturer. A restocking fee will apply.

6. **Entire Obligation:** This Limited Warranty states the entire obligation of Manufacturer with respect to the Products. If any part of this Limited Warranty is determined to be void or illegal, the remainder shall remain in full force and effect.

US / Canada Non-Exclusive 2016



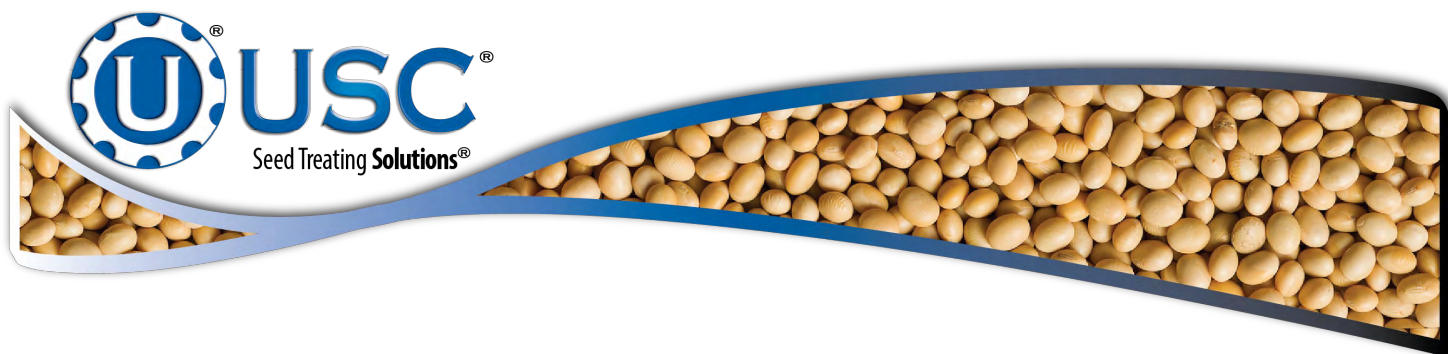

USC, LLC

2320 124th road

Sabetha, KS 66534

PHONE: (785) 431-7900

FAX: (785) 431-7950

EMAIL: sales-team@uscllc.com

WEB: www.uscllc.com

