



TS3500 TRUCK UNLOAD CONVEYOR



Operators Manual

Document: TD-09-06-1044

Revision: C



INTRODUCTION

Thank you for choosing USC, LLC for your equipment needs. We appreciate your business and will work diligently to ensure that you are satisfied with your choice.

OVERVIEW

The purpose of this manual is to provide you with the basic information needed to operate and maintain the Truck Unload Conveyor . It does not hold USC, LLC liable for any accidents or injuries that may occur.

The technical information provided in this document is based on extensive testing under controlled conditions at the USC research and development facility. This information is given without guarantee as the conditions of operation and storage of the equipment are beyond our control. Variables such as temperature, humidity, viscosity of chemical products and changes in seed size or variety may all effect the accuracy of application and seed coverage. Periodically check the equipment calibration while treating and make adjustments as required. This will insure the optimum seed coverage.

OPERATOR RESPONSIBILITIES

As the purchaser/owner/operator of this equipment and control system, you have an obligation to install, operate, and maintain the equipment in a manner that minimizes the exposure of people in your care to any potential hazards inherent in using this equipment. It is critical that the owner of this equipment:

- Has a clear and documented understanding of the process this machine is being used in and of any resulting hazards or special requirements arising from this specific application.
- Allow only properly trained and instructed personnel to install, operate or service this equipment.
- Maintain a comprehensive safety program involving all who work with this machine and other associated process equipment.
- Establish clear areas of staff responsibility (e.g. operation, setup, sanitation, maintenance, and repairs).
- Provide all personnel with necessary safety equipment.
- Periodically inspect the equipment to insure that the doors, covers, guards, and safety devices are in place and functioning, that all safety instructions and warning labels are intact and legible, and that the equipment is in good working order.
- In addition to the operating instructions, observe and enforce the applicable legal and other binding regulations, national and local codes.

TS3500 TRUCK UNLOAD CONVEYOR

As the person with the most to gain or lose from working safely, it is important that you work responsibly and stay alert. By following a few simple rules, you can prevent an accident that could injure or kill you or a co-worker.

- Disconnect, lockout, and tagout electrical and all other energy sources before inspecting, cleaning, servicing, repairing, or any other activity that would expose you to the hazards of electrical shock.
- Do not operate, clean, or service this equipment until you have read and understood the contents of this manual. If you do not understand the information in this manual, bring it to the attention of your supervisor, or call USC at (785) 431-7900 for assistance.
- Any operator who is known or suspected to be under the influence of alcohol or drugs should not be allowed to operate the equipment.
- Understand and follow the safety practices required by your employer and this manual.
- **PAY ATTENTION** to what you and other personnel are doing and how these activities may affect your safety.
- **Failure to follow these instructions may result in serious personal injury or death.**

RECEIVING YOUR EQUIPMENT

As soon as the equipment is received, it should be carefully inspected to make certain that it has sustained no damage during shipment and that all items listed on the packing list are accounted for. If there is any damage or shortages, the purchaser must immediately notify USC, LLC. Ownership passes to purchaser when the unit leaves the USC, LLC. premises. The purchaser is responsible for unloading and mounting all components of the equipment.

Document the serial number of the machine for future reference. The serialization label is located on the side of the conveyor head assembly.



*Serial
Number*

SERIAL NUMBER: _____

TABLE OF CONTENTS

<u>Section</u>	<u>Contents</u>	<u>Page #</u>
Section A	Safety Instructions	5
Section B	Mechanical Operation	15
	System Overview	16
	Controls, Pre-Operation Checklist, Operation	17
	Operating Hints, Emergency Stopping, Restarting	18
	Machine Break-in	19
Section C	Troubleshooting	20
Section D	Maintenance.....	21
	Tail End Belt Tensioning & Alignment	23
	Head End Belt Alignment & Belt Replacement.....	24
	Drive Belt Tensioning & Alignment	25
Section E	Belt Tensioning Specification	26
Section F	Storage.....	27
Section G	Mechanical Drawings.....	29
Section H	Limited Warranty	45

SAFETY INSTRUCTIONS

SECTION A

Every year accidents in the work place maim, kill and injure people. Although it may be impossible to prevent all accidents, with the right combination of training, operating practices, safety devices and operator vigilance, the number of accidents can be significantly reduced. The purpose of this section is to educate equipment users about hazards, unsafe practices and recommended hazard avoidance techniques.

SAFETY WORDS AND SYMBOLS

It is very important that operators and maintenance personnel understand the words and symbols that are used to communicate safety information. Safety words, their meaning and format, have been standardized for U.S. manufacturers and published by the American National Standards Institute (ANSI). The European Community (E.C.) has adopted a different format based on the International Standards Organization (I.S.O.) and applicable machinery directives. Both formats are presented below. Graphic symbols are not standardized but most manufacturers will use some variation of the ones seen in this manual.



Indicates an imminently hazardous situation which, if not avoided, **will** result in death or serious injury.



Indicates a potentially hazardous situation which, if not avoided, **could** result in death or serious injury.



Indicates a potentially hazardous situation which, if not avoided, **may** result in minor or moderate injury and/or property damage.



Provides additional information that the operator needs to be aware of to avoid a potentially hazardous situation.



Mandatory Lockout Power Symbol. Disconnect, lockout and tagout electrical and other energy sources before inspecting, cleaning or performing maintenance on this panel.



International Safety Alert Symbol. The exclamation point (!) surrounded by a yellow triangle indicates that an injury hazard exists. However, it does not indicate the seriousness of potential injury. The exclamation point (!) is also used with the DANGER, WARNING and CAUTION symbols so the potential injury is indicated.



Electrocution Hazard Symbol. This symbol indicates that an electrocution hazard exists. Serious injury or death could result from contacting high voltage.



International Electrocution Hazard. This symbol indicates that an electrocution hazard exists. Serious injury or death could result from contacting high voltage.



Mandatory Read Manual Action Symbol. (I.S.O. format) This symbol instructs personnel to read the Operators Manual before servicing or operating the equipment.



Mandatory Read Manual Action Symbol. This symbol instructs personnel to read the Operators Manual before servicing or operating the equipment.

NOTICE

Notice is used to notify people of important installation, operation or maintenance information which is not hazard related.

LOCKOUT / TAGOUT PROCEDURES

Lockout/Tagout is the placement of a lock/tag on an energy isolating device in accordance with an established procedure. When taking equipment out of service to perform maintenance or repair work, always follow the lockout/tagout procedures as outlined in ANSI Z344.1 and/or OSHA Standard 1910.147. This standard “requires employers to establish a program and utilize procedures for affixing appropriate lockout devices or tagout devices to energy isolating devices and to otherwise disable machines or equipment to prevent unexpected energizing, start-up, or release of stored energy in order to prevent injury to employees.”

CONTROLLED STOP

This is the stopping of machine motion by reducing the electrical command signal to 0 (zero) once the stop signal has been recognized.

HAZARD REVIEW

Electrocution Hazard



Electrocution accidents are most likely to occur during maintenance of the electrical system or when working on or near exposed high voltage wiring. This hazard does not exist when the electrical power has been disconnected, properly locked, and tagged out.

Automatic Start Hazard



This equipment may be controlled by an automated system and may start without warning. Failure to properly disconnect, lockout, and tagout all energy sources of remotely controlled equipment creates a very hazardous situation and could cause injury or even death. PLEASE STAY CLEAR AND BE ALERT.

YOU are responsible for the **SAFE** operation and maintenance of your USC, LLC equipment . **YOU** must ensure that you and anyone else who is going to operate, maintain or work around the equipment be familiar with the operating and maintenance procedures and related **SAFETY** information contained in this manual. This manual will take you step-by-step through your working day and alert you to good safety practices that should be adhered to while operating the equipment

Remember, **YOU** are the key to safety. Good safety practices not only protect you, but also the people around you. Make these practices a working part of your safety program. Be certain that **EVERYONE** operating this equipment is familiar with the recommended operating and maintenance procedures and follows all the safety precautions. Most accidents can be prevented. Do not risk injury or death by ignoring good safety practices.

- Equipment owners must give operating instructions to operators or employees before allowing them to operate the machine, and at least annually thereafter per OSHA (Occupational Safety and Health Administration) regulation 1928.57.
- The most important safety device on this equipment is a **SAFE** operator. It is the operator's responsibility to read and understand **ALL** Safety and Operating instructions in the manual and to follow them. All accidents can be avoided.
- A person who has not read and understood all operating and safety instructions is not qualified to operate the machine. An untrained operator exposes himself and bystanders to possible serious injury or death.
- Do not modify the equipment in any way. Unauthorized modification may impair the function and/or safety and could affect the life of the equipment.
- Think SAFETY! Work SAFELY!

GENERAL SAFETY

1. Read and understand the operator's manual and all safety labels before operating, maintaining, adjusting or unplugging the equipment .
2. Only trained persons shall operate the equipment . An untrained operator is not qualified to operate the machine.
3. Have a first-aid kit available for use should the need arise, and know how to use it.



4. Provide a fire extinguisher for use in case of an accident. Store in a highly visible place.
5. Do not allow children, spectators or bystanders within hazard area of machine.
6. Wear appropriate protective gear. This includes but is not limited to:



- A hard hat
- Protective shoes with slip resistant soles
- Protective goggles
- Heavy gloves
- Hearing protection
- Respirator or filter mask



7. Place all controls in neutral or off, stop motor, and wait for all moving parts to stop. Then disable power source before servicing, adjusting, repairing, or unplugging.
8. Review safety related items annually with all personnel who will be operating or maintaining the equipment.



OPERATING SAFETY:

1. Read and understand the operator's manual and all safety labels before using.
2. Disconnect and disable electrical supply completely and wait for all moving parts to stop before servicing, adjusting, repairing or unplugging.
3. Clear the area of bystanders, especially children, before starting.
4. Be familiar with the machine hazard area. If anyone enters hazard area, shut down machine immediately. Clear the area before restarting.
5. Keep hands, feet, hair and clothing away from all moving and/or rotating parts.
6. Stay away from overhead obstructions and power lines during operation and transporting. Electrocutation can occur without direct contact.
7. Do not operate machine when any guards are removed.
8. Inspect welds and repair if needed.

MAINTENANCE SAFETY

1. Review the operator's manual and all safety items before working with, maintaining or operating the equipment .
2. Place all controls in neutral or off, stop motors, disable power source, and wait for all moving parts to stop before servicing, adjusting, repairing or unplugging.
3. Follow good shop practices:
Keep service area clean and dry.
Be sure electrical outlets and tools are properly grounded.
Use adequate light for the job at hand.
4. Keep hands, feet, hair and clothing away from all moving and/or rotating parts.
5. Clear the area of bystanders, especially children, when carrying out any maintenance and repairs or making any adjustments.
6. Before resuming work, install and secure all guards when maintenance work is completed.
7. Keep safety labels clean. Replace any sign that is damaged or not clearly visible.

SAFETY LABELS

1. Keep safety labels clean and legible at all times.
2. Replace safety labels that are missing or have become illegible.
3. Replaced parts that displayed a safety label should also display the current label.
4. Replacement safety labels are available. Contact USC at (785) 431-7900 .

How to Install Safety Labels:

- Be sure that the installation area is clean and dry.
- Be sure temperature is above 50°F (10°C).
- Decide on the exact position before you remove the backing paper.
- Remove the smallest portion of the split backing paper.
- Align the sign over the specified area and carefully press the small portion with the exposed sticky backing in place.
- Slowly peel back the remaining paper and carefully smooth the remaining portion of the sign in place.
- Small air pockets can be pierced with a pin and smoothed out using the piece of sign backing paper.



Located on the USC equipment you will find safety labels. Always be sure to read and follow all directions on the labels.



Guards provided with USC equipment are to remain in place during operation.

Think **SAFETY!** Work **SAFELY!**

REMEMBER—If safety labels have been damaged, removed, become illegible, or parts replaced without safety labels, new labels must be applied. New safety labels are available from USC at (785) 431-7900.



Part # 09-02-0011



TS3500 TRUCK UNLOAD CONVEYOR



Part # 09-02-0001



Part # 09-02-0002



Part # 09-02-0015



TS3500 TRUCK UNLOAD CONVEYOR

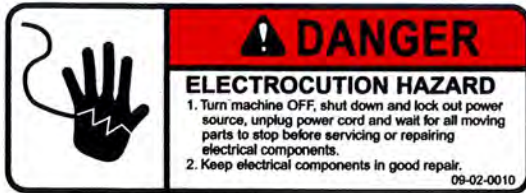
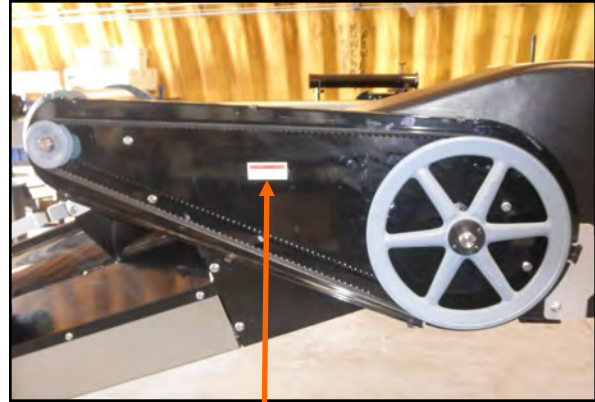

Part # 09-02-0010



Part # 09-02-0012



Part # 09-02-0009

MECHANICAL OPERATION

SECTION B



OPERATING SAFETY

1. Read and understand the Operator's Manual and all safety signs before using.
2. Electric motor drives: Disconnect and disable electrical supply completely and wait for all moving parts to stop before servicing, adjusting, repairing or unplugging.
3. Clear the area of bystanders, especially children, before starting.
4. Be familiar with machine hazard area. If anyone enters hazard areas, shut down machine immediately. Clear the area before restarting.
5. Keep hands, feet, hair and clothing away from all moving and/or rotating parts.
6. Do not allow riders on the Conveyor or transport vehicle when transporting.
7. Stay away from overhead obstructions and power lines during operation and transporting. Electro-cution can occur without direct contact.
8. Do not operate machine when any guards are removed.
9. Lower Conveyor to its lowest position before moving or transporting or when not in use.
10. Inspect lift cable before using Conveyor. Replace if frayed or damaged.
11. Make certain lift cable is properly seated in cable pulleys.
12. Be sure that conveyor is empty before raising or lowering.

The Truck Unload Conveyor is designed to efficiently move seed from a truck to a bin fill conveyor or a seed treater inlet conveyor. Power is provided by an electric motor. Be familiar with the machine before starting.

It is the responsibility of the owner or operator to read this manual and to train all other operators before they start working with the machine. In addition to the design and configuration of equipment, hazard control and accident prevention are dependent upon the awareness, concern, and prudence of personnel involved in the operation, transport, maintenance and storage of equipment or in the use and maintenance of facilities.

NOTICE

Follow all safety instructions exactly. Safety is everyone's business. By following recommended procedures, a safe working environment is provided for the operator, bystanders and the area around the worksite. Untrained operators are not qualified to operate the machine.

Many features incorporated into this machine are the result of suggestions made by customers like you. Read this manual carefully to learn how to operate the machine safely and how to set it to provide maximum efficiency. By following the operating instructions in conjunction with a good maintenance program, your conveyor will provide many years of trouble free service.

CONVEYOR OVERVIEW

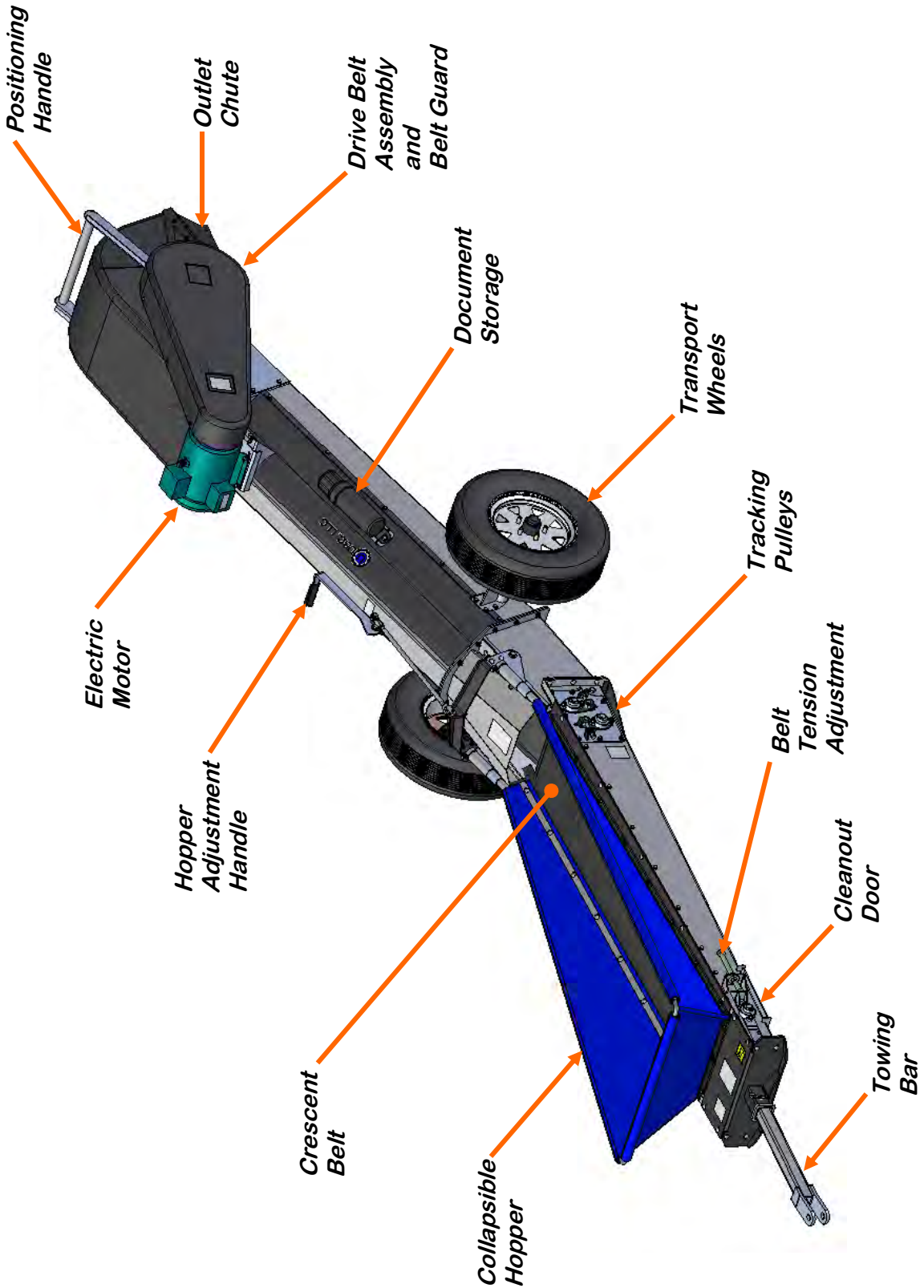

CONTROLS

Electric Drive: Have a licensed electrician provide power to the machine per the National Electrical Code ANSI/NFPA 70 and local codes. For customer safety and ease of use, a motor on / off switch may be mounted on the conveyor.

PRE-OPERATION CHECKLIST

Efficient and safe operation of the Truck Unload Conveyor requires that each operator reads and understands the operating procedures and all related safety precautions outlined in this section. A pre-operation checklist is provided for the operator. It is important for both the personal safety and maintaining the good mechanical condition of the Conveyor that this checklist is followed.

Before operating the Conveyor and each time thereafter, the following areas should be checked off:

1. Service the machine per the schedule outlined in Section D, Maintenance (see page 21).
2. Use only an electric motor of adequate power to operate the machine.
3. Check that all guards are installed, secured and functioning as intended. Do not operate with missing or damaged shields.
4. Check worksite. Clean up working area to prevent slipping or tripping.
5. Check that drive belt and conveying belt are not frayed or damaged and that they are properly adjusted and aligned.
6. Check that discharge chute is free of obstructions.

OPERATION

1. Clear the area of bystanders before starting the equipment.
2. Review the workplace Hazards schematic and use extra care when inside the hazard area, Keep all bystanders out of this area. Should anyone enter this area, stop the machine immediately.
3. Turn the Truck Unload Conveyor motor on and crank the truck seed gate open to begin conveying seed away from your truck.
4. To stop the conveyor shut the truck gate and run until the belt is clear of material. Then turn off the conveyor motor.

OPERATING HINTS

- Always listen for any unusual sounds or noises. If any are heard, stop the machine and determine the source. Correct the problem before resuming work.
- Never allow anyone into the workplace hazard area. If anyone enters, stop immediately. Make them LEAVE before resuming work.
- Do not run the machine for long periods of time with no material on the belt. It increases the wear. Try to run the conveyor only when moving material.
- Always check and make sure the belt is properly aligned. Neglecting your belt may lead to wear and possible breakage.
- Always disconnect power from the conveyor when its not being operated in case of power surges.

EMERGENCY STOPPING

Although it is recommended that the machine be emptied before stopping, in an emergency situation, stop or shutdown the power source immediately. Correct the emergency before resuming work.

RESTARTING

When the machine is shut down inadvertently or for an emergency, the belt may still be covered with material. It may be necessary to tighten the drive belt slightly to handle the heavier-than-normal starting loads.

MACHINE BREAK-IN

Although there are no operational restrictions on the conveyor when used for the first time, it is recommended that the following mechanical items be checked:

Before Starting

1. Read the Conveyor Operator's Manual.
2. During the conveyors first few minutes of operation, check conveyor belt alignment to ensure belt is tracking correctly when running empty and also during loaded conditions.

After Operating for 1/2 Hour

1. Re-torque fasteners and hardware.
2. Check that all safety decals are installed and legible. Apply new decals if required.
3. Check the drive belt tension and alignment. Tension or align as required.
4. Check the conveying belt tension and alignment. Tension or align as required.
5. Check that all guards are installed and working as intended.

After Operating for 5 Hours and 10 Hours

1. Re-torque all bolts, fasteners and hardware.
2. Check that all guards are installed, secured and functioning as intended. Do not operate with missing or damaged shields.
3. Check safety decals. Install new ones if required.
4. Check the drive belt, and conveying belt tension and alignment. Tension or align as required.
5. Then go to the normal servicing and maintenance schedule as defined in the Maintenance Section.

SECTION
C**TROUBLESHOOTING**

Below is a table describing the most frequent problems and solutions with the Truck Unload Conveyor. For further assistance, contact USC at (785) 431-7900.

Problem	Possible Cause	Solution
Conveyor will not run.	<ol style="list-style-type: none"> 1. Not turned on. 2. Conveying belt loose. 3. Drive belt loose. 	<ol style="list-style-type: none"> 1. Start power source or turn power on. 2. Tighten and align belt. 3. Tighten drive belt.
Belt edge fraying.	<ol style="list-style-type: none"> 1. Belt not aligned. 	<ol style="list-style-type: none"> 1. Align and tension belt.
Low conveying capacity.	<ol style="list-style-type: none"> 1. Slow operating speed. 2. Conveyor belt slipping. 3. Drive belt slipping. 	<ol style="list-style-type: none"> 1. Increase operating speed. 2. Tighten belt. 3. Set drive belt tension.

Unplugging

In unusual moisture or material conditions, the machine can plug. When plugging occurs, follow this procedure:

1. Place all controls in neutral or off, stop motor, disable and lock out power source before unplugging.
2. Unbolt and remove the necessary conveyor covers.
3. Remove built up material.
4. Install and secure conveyor covers.
5. Remove the fastener that is holding the cleanout door in place on the bottom of the inlet side of the conveyor. Slide the door out and remove any built up material.
6. Install and secure cleanout door.

MAINTENANCE

SECTION D

Proper maintenance of the Truck Unload Conveyor is critical for peak performance, reliability and accuracy of this system. The following is a guideline for the type of maintenance and servicing that should be performed on this unit. Your environment and uses may require additional maintenance and service beyond this list to assure a reliable and safe unit. The operator of this unit has ultimate responsibility to identify areas of concern and rectify them before they become a hazard or safety issue. There is no substitute for a trained, alert operator.



Do not put this unit into operation with any questionably maintained parts. Poor performance or a hazard may occur.



Failure to maintain the proper belt tension will cause the belt to slip. This will damage the belt and head drive pulley. If the belt is not tracking correctly, it can ride along one edge causing the belt to fray and damage the belt splice. Either problem will cause the belt to burn or wear out prematurely.

FLUIDS AND LUBRICANTS

Grease

Use an SAE multipurpose high temperature grease with extreme pressure (EP) performance. Also acceptable is an SAE multipurpose lithium-based grease.

Hydraulic Oil

Use DTE 24 hydraulic oil for Electric Powered Hydraulic Pack.

Storing Lubricants

Your machine can operate at top efficiency only if clean lubricants are used. Use clean containers to handle all lubricants. Store them in an area protected from dust, moisture and other contaminants.

GREASING

Use a Maintenance Checklist to keep record of all scheduled maintenance.

1. Use a hand-held grease gun for all greasing.
2. Wipe grease fitting with a clean cloth before greasing to avoid injecting dirt and grit.
3. Replace and repair broken fittings immediately.



If fittings will not take grease, remove and clean thoroughly. Also clean lubricant passageway. Replace fitting if necessary.

TS3500 TRUCK UNLOAD CONVEYOR
CONVEYOR SERVICING INTERVALS

Every 40 hours or Weekly

1. Check the conveyor belt tension and alignment.
2. Grease conveyor bearings.
 - A. Two bolt flanged bearings, tail roller bearings right and left (2 locations).
 - B. Two bolt flanged bearings, drive roller bearings right and left (2 locations).
 - C. Four bolt flanged bearings, jackshaft bearings right and left at transition (2 locations).
3. Remove guard and check the drive belt tension and alignment. The belts will deflect approximately 1/4 to 1/2 inch when properly tensioned.

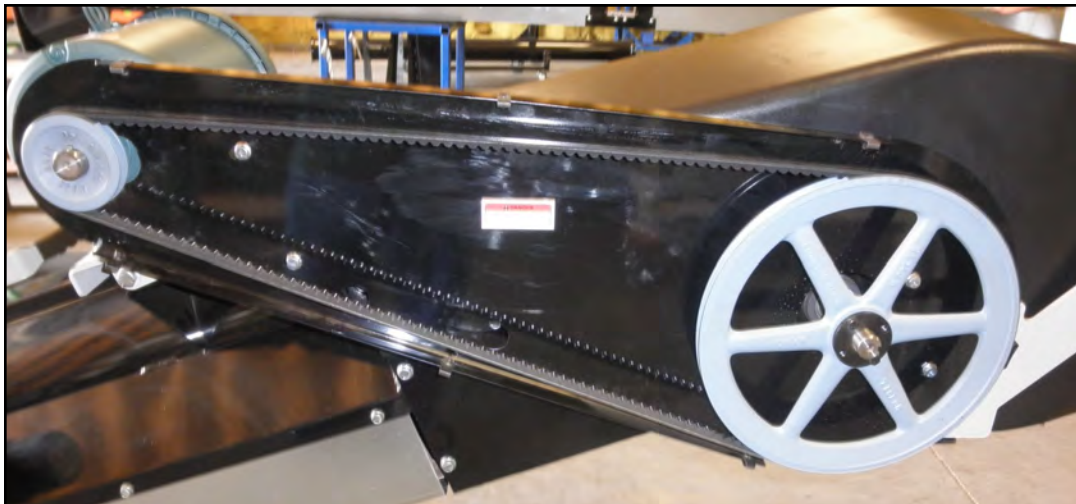
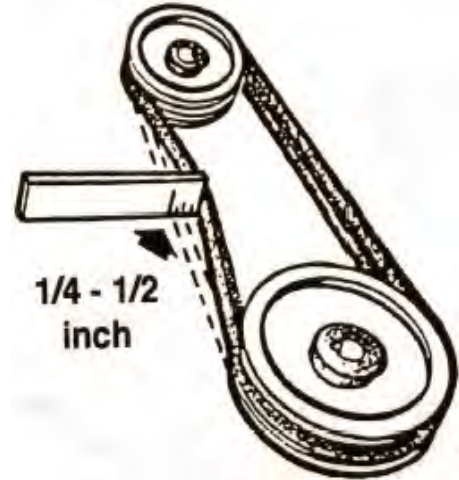

Every 200 hours or Annually

1. Wash machine.
2. Check pulley bushing for wear. To inspect pulley:
 - A. Loosen and remove the bolt.
 - B. Inspect the bushing on the pulley for wear.
 - C. Reverse steps A & B for re-assembly.

CONVEYING BELT TENSION AND ALIGNMENT - TAIL END

A contoured crescent belt is used to convey material along the frame. The tension and alignment of the belt should be checked weekly, or more often if required, to be sure that it does not slip or run to one side. A properly tensioned belt will not slip when it is operating. Operating the belt with less slippage will increase the belt life and causes less stress on bearings, pulleys and shafts.

⚠ WARNING

Although it is acceptable to align the belt from either the Head or the Tail end. Tightening the belt may only be done from the Tail end of the conveyor

To maintain the belt, follow this procedure:

NOTICE

Place all controls in neutral or off, stop motor and disable power source before working on belt.

1. Use the take-up bolt located at the tail to set the tension of the belting.
2. If the belt needs to be tightened to prevent slippage, use the take-up adjustments on the tail end only.
3. The belt is tightened by turning both take-up adjustments an **equal** number of turns.
4. Use the drive roller to check the alignment. The belt should be centered.
5. Turn the belt 1/2 revolution when the belt is new and check the drive and tail roller. If out of alignment, the belt will move to the loose side. Loosen the jam nut and use the bearing position bolts to set the position. Tighten jam nut.
6. Run and check again. Check frequently during the first few minutes of operation and then several times during the first 10 hours. The belt normally seats itself during the first 10 hours of operation and can be checked weekly after that.
7. The belt is properly aligned when the belt runs in the center of the head and tail rollers.

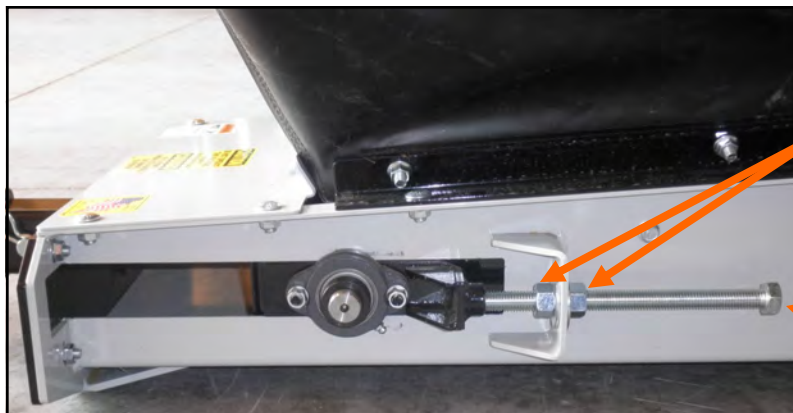

Loosen the jam nuts before adjusting the bearing position bolt

Use this bolt to tighten and align the belt

CONVEYING BELT ALIGNMENT - HEAD END

1. A misaligned belt will track toward the loose side. Set the tracking by loosening the jam nuts on the tight side and using the bearing position bolt to move the end of the head roller toward the tail. The same method is used on the transition rollers pictured below. Tighten the jam nuts when the belt is centered on the head roller. When installing a new belt, start out with the pointer in the center of the hole.
2. Run the belt and check the tracking again. Loosen the tight side slightly again if required. Repeat the adjusting and checking procedure until the belt centers on the input end roller and remains centered when running.
3. Always repeat this aligning procedure when installing a new belt. Check frequently during the first 10 hours of operation. After 10 hours, the belt is normally seated and checking the alignment can be done less frequently.



Tighten jam nut after adjustment

Use this bolt to align the belt

BELT REPLACEMENT

1. Remove the cover from the tail section (bottom, right) Rotate the belt until the seam is visible.
2. Move the tail roller to its loosest position.
3. Pull all the slack to the seam area.
4. Remove the wire connector and open the belt.
5. Attach one end of the replacement belt to the belt end being removed.
6. Pull the old belt out and the new belt will be threaded into place.
7. Disconnect the old belt.
8. Connect the ends of the new belt together and secure.
9. Set the belt tension.
10. Check and set the belt alignment.

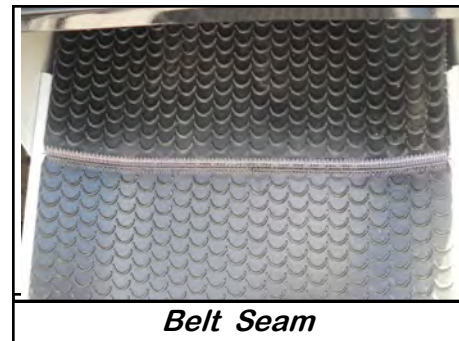

Belt Seam

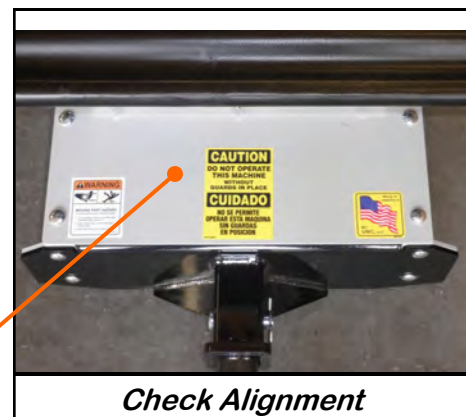

Remove Cover

Check Alignment

DRIVE BELT TENSION & ALIGNMENT

Power to the conveying belt is transmitted through a V-belt. The V-belt drive system must be maintained at the proper belt tension and pulley alignment to obtain the desired performance and life. When maintaining the belt drive system follow this procedure:

NOTICE

Turn motor off and unplug power cord or turn off power and lock out the master panel before starting maintenance on drive belt system.

Drive Belt Tension

1. Push on the center of the belt span with a force of approximately 5 to 10 lbs.
2. Follow the belt tensioning specification on page 26 to determine proper belt deflection.
3. Back off the jam nut, then move the motor up using the adjustment bolt. When the tension is correct, tighten the jam nut (top right).
4. Attach and secure guards.

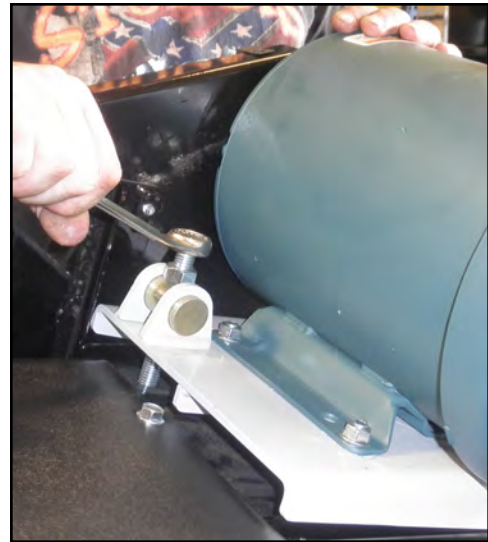

Motor base adjustment

Drive Belt Alignment

1. Lay a straightedge across the pulley faces to check the alignment (bottom).
2. Use the pulley hub to move the pulley to the required position for alignment.
3. Tighten hub bolts to secure pulley on shaft.
4. Check belt tension
5. Close and secure guards.

Drive Belt Replacement

1. Lower motor to its loosest position.
2. Remove old belt and replace with a new one.
3. Raise motor to set the belt tension.
4. Check pulley alignment. Adjust if required.
5. Close and secure guards.

*Lay a straight edge
across pulley faces*



**SECTION
E**

BELT TENSIONING SPECIFICATION

V-Belt tensioning adjustment can be made using a tension meter or other type spring scale using the following procedure. After seating the belts in the groove and adjusting center distance so as to take up the slack in the belts, further increase the tension until only a slight bow on the slack side is apparent while the drive is operating under load. Stop the drive and using the meter, measure the force necessary to depress one of the center belts 1/64 inch for every inch of belt span (see sketch below). For example, a deflection for a 50 inch belt span is 50/64 or 25/32 inch. The amount of force required to deflect the belt should compare with the deflection forces noted in the table below. Also notice for V- Belts that deflection forces vary from the initial RUN - IN values which are greater (reflecting higher run-in tensioning) to the NORMAL values for after the run-in period.

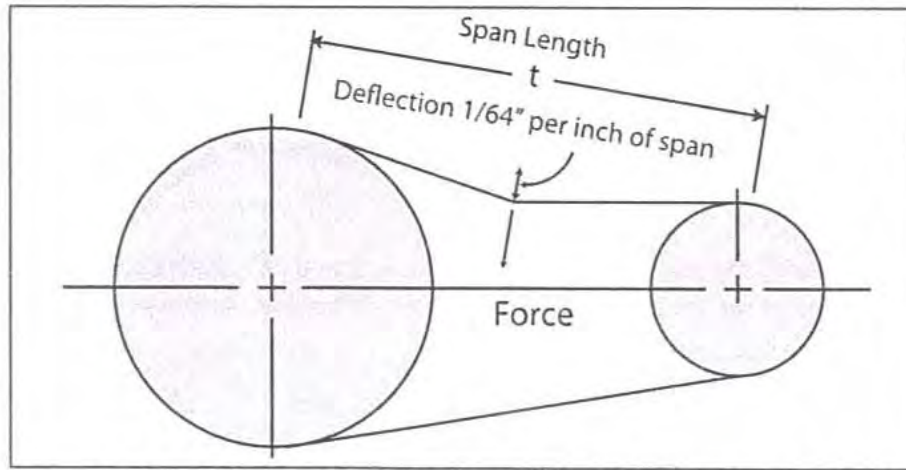

MEASURE THE SPAN LENGTH "T" AS SHOWN IN THE SKETCH ABOVE.

BELT CROSS SECTION	SMALLER PULLEY DIAMETER RANGE (inches)	DEFLECTION FORCE	
		RUN - IN (lbs)	NORMAL (lbs)
AX	3.0 - 3.6	4 - 1/8	2 - 3/4
	3.8 - 4.8	5	3 - 1/4
	5.0 - 7.0	6	4
BX	3.4 - 4.2	5 - 1/4	3 - 1/2
	4.4 - 5.2	7 - 1/8	4 - 3/4
	5.4 - 9.4	9	6

When storing the Truck Unload Conveyor for long periods of time, the following procedure must be followed to reduce the chance of rust, corrosion and fatigue of the conveyor. You can also use these steps when storing the machine for the winter.



A dust mask and protective rubber gloves shall be used when cleaning the machine.

1. Clear the area of bystanders, especially small children.
2. Thoroughly wash the entire machine to remove all dirt, mud, debris or residue.
3. Inspect all moving or rotating parts to see if anything has become entangled in them. Remove the entangled material.
4. Lubricate all grease fittings. Make sure that all grease cavities have been filled with grease to remove any water residue from the washing. This also protects the bearing seals.
5. Remove drive assembly cover. Clean entire area and ensure drive belt and chain are clean and free of debris. Lubricate drive chain.
6. Touch up all paint nicks and scratches to prevent rusting.
7. Move to storage area.
8. Select an area that is dry, level and free of debris.
9. If the machine cannot be placed inside, cover the electric motor with a water proof tarpaulin and tie securely in place.
10. Store machine in an area away from human activity.
11. Do not allow children to play on or around the stored machine.

TS3500 TRUCK UNLOAD CONVEYOR

NOTES:

MECHANICAL DRAWINGS

SECTION G

MANUAL TUBE ASSEMBLY (13-05-0332)

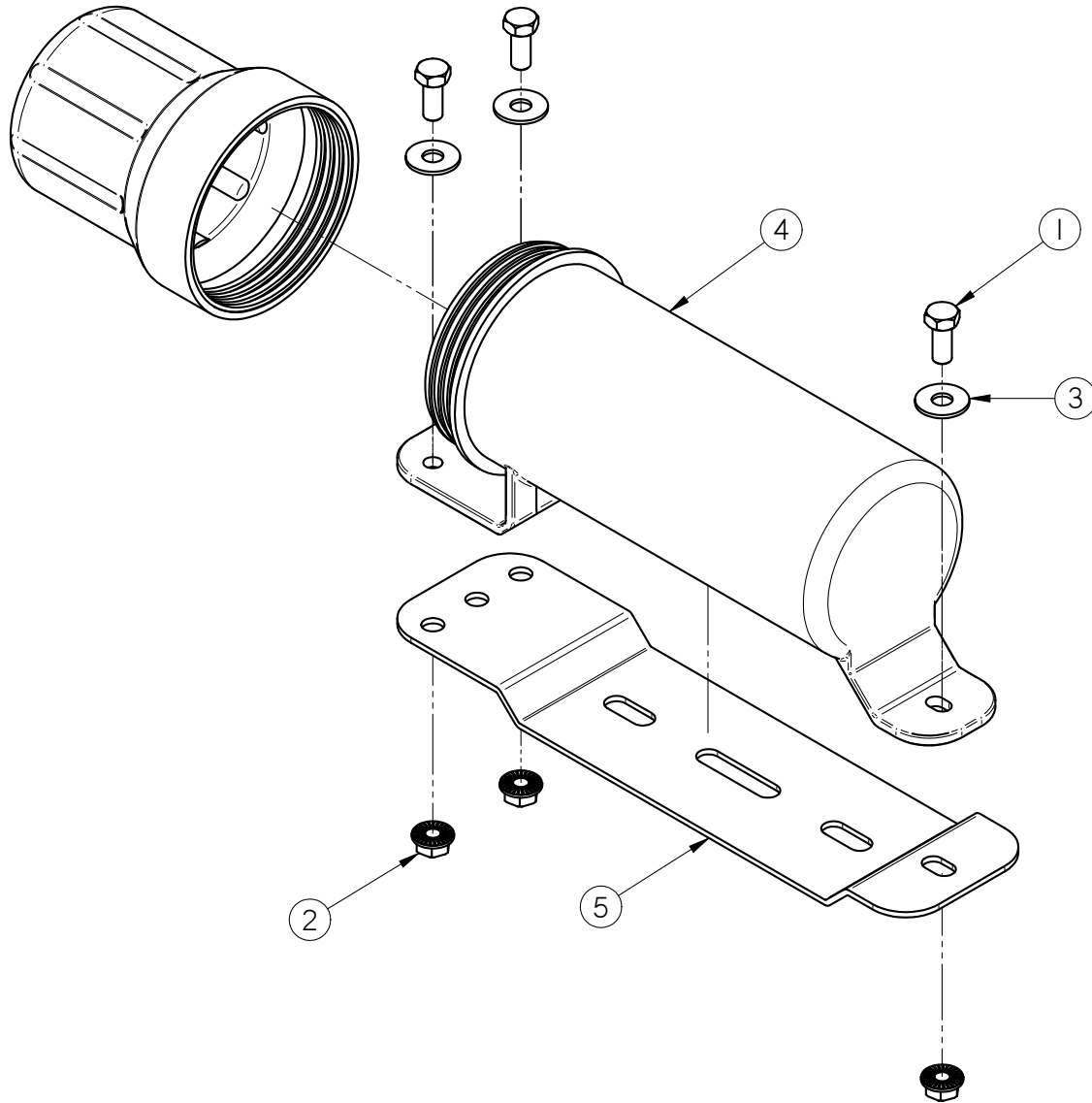

Item #	Part #	Description	Qty
1	06-01-0010	BOLT .313-18 X 0.75 ZP GR5	3
2	06-03-0019	NUT, FLG .3125-18 UNC ZP GRADE 5	3
3	06-05-0011	WASHER, .3125 FLAT 18-8 SS	3
4	08-07-0050	HOLDER MANUAL 3.25 DIA	1
5	103980	PLT MANUAL MT	1

TS3500 TRUCK UNLOAD CONVEYOR
TARP LINK LIFT ASSEMBLY (13-08-0563)

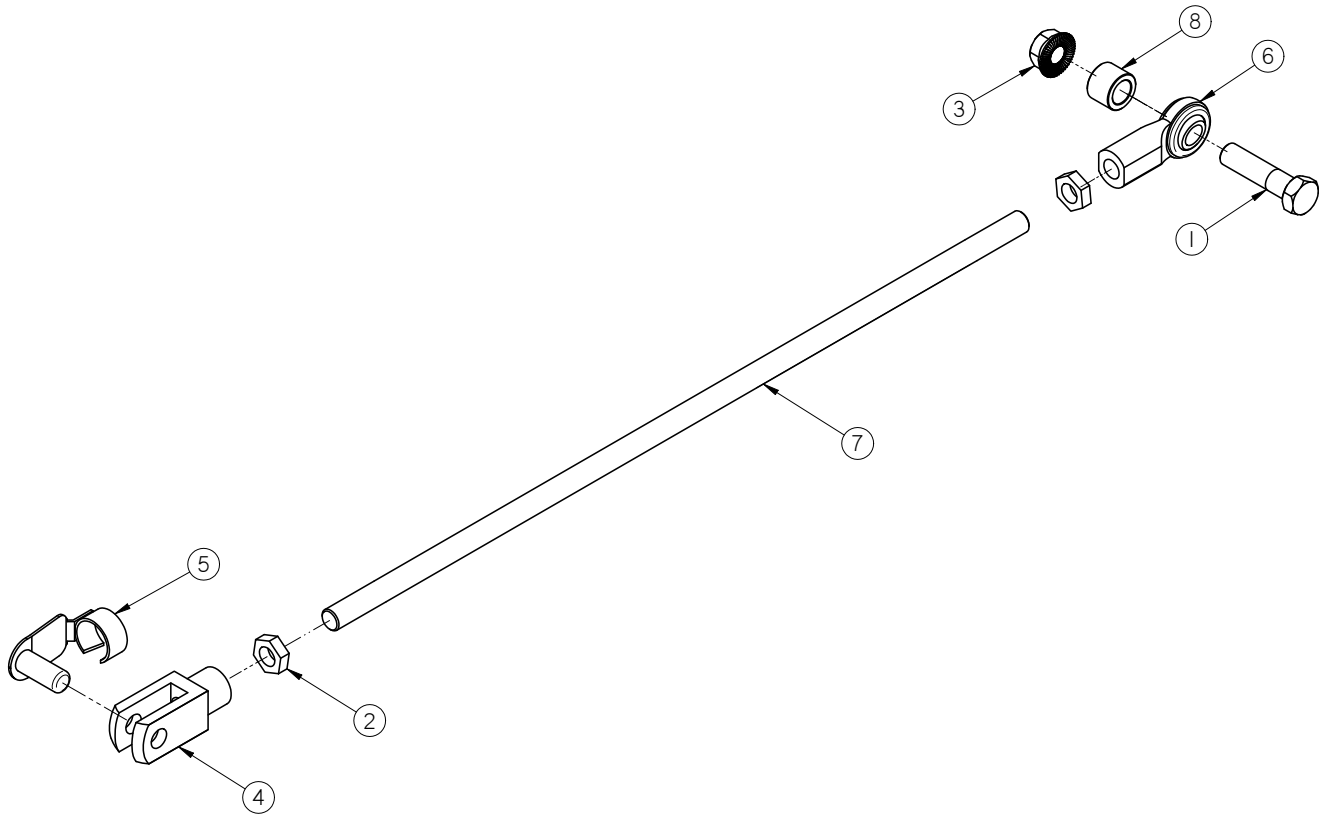

Item #	Part #	Description	Qty
1	06-01-0027	BOLT .500-13 X 2.00 ZP GR5	1
2	06-02-0015	NUT JAM .500-20 ZP GR5	2
3	06-03-0015	NUT LOCK FLG .500-13 ZP GR5	1
4	06-12-0008	CLVS .500-20 X .500	1
5	06-12-0009	PIN CLIP SPRING .500	1
6	06-12-0010	BALL JOINT ROD ENDS PURCHASED	1
7	104119	ROD TARP ADJ	1
8	10411A	SPACER LINK	1

RIGHT HALF SEED GUIDE ASSEMBLY (13-08-0561)

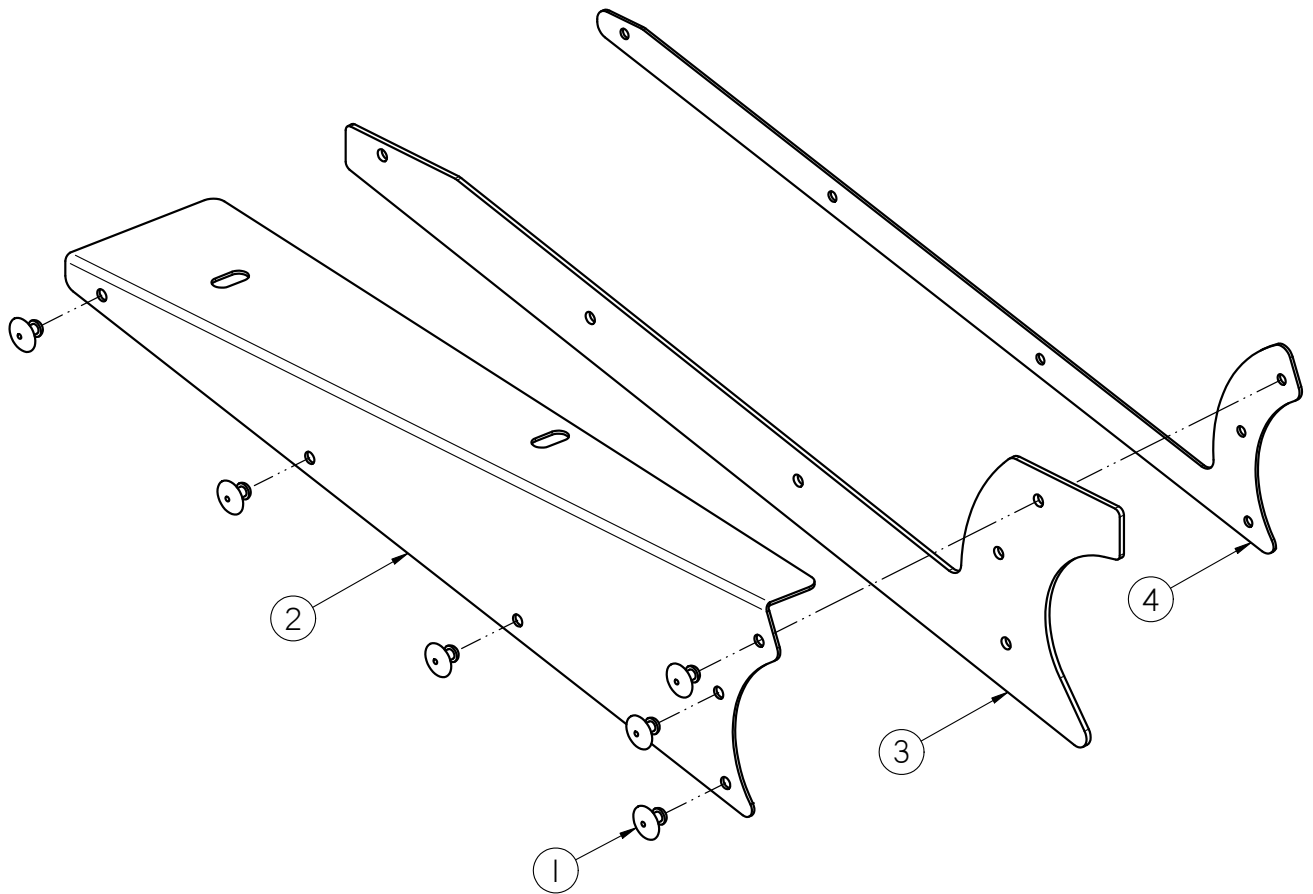

Item #	Part #	Description	Qty
1	06-12-0022	RIVET POP .188 X .312 GRIP SS .65HD	6
2	1040CA	PLT SEED GUIDE RH	1
3	1040CB	SKIRT RBBR RH	1
4	1040CC	PLT SKIRT BACKING	1

LEFT HALF SEED GUIDE ASSEMBLY (13-08-0562)

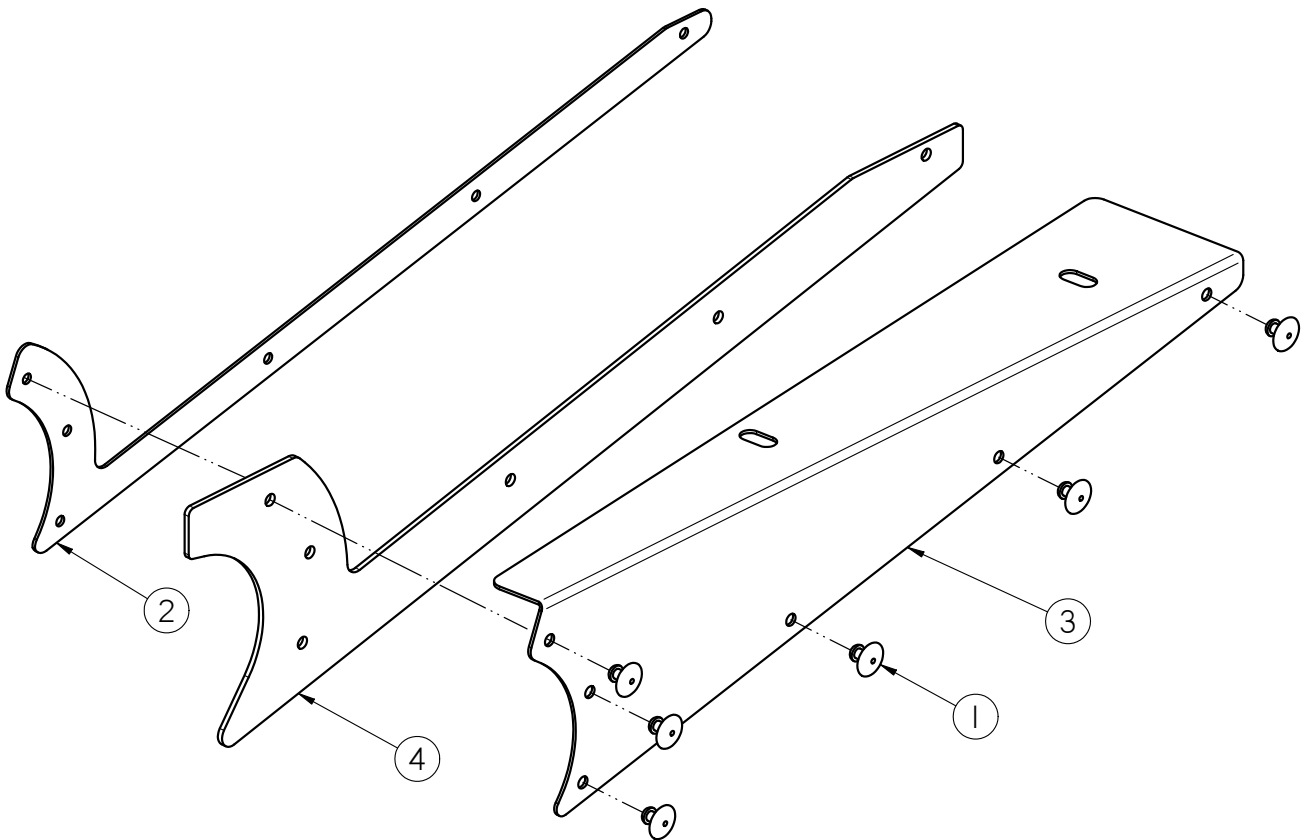

Item #	Part #	Description	Qty
1	06-12-0022	RIVET POP .188 X .312 GRIP SS .65HD	6
2	1040CC	PLT SKIRT BACKING	1
3	1040CD	PLT SEED GUIDE LH	1
4	1040CE	SKIRT RBBR LH	1

HEAD TRACKING PLATE ASSEMBLY (13-08-0564)

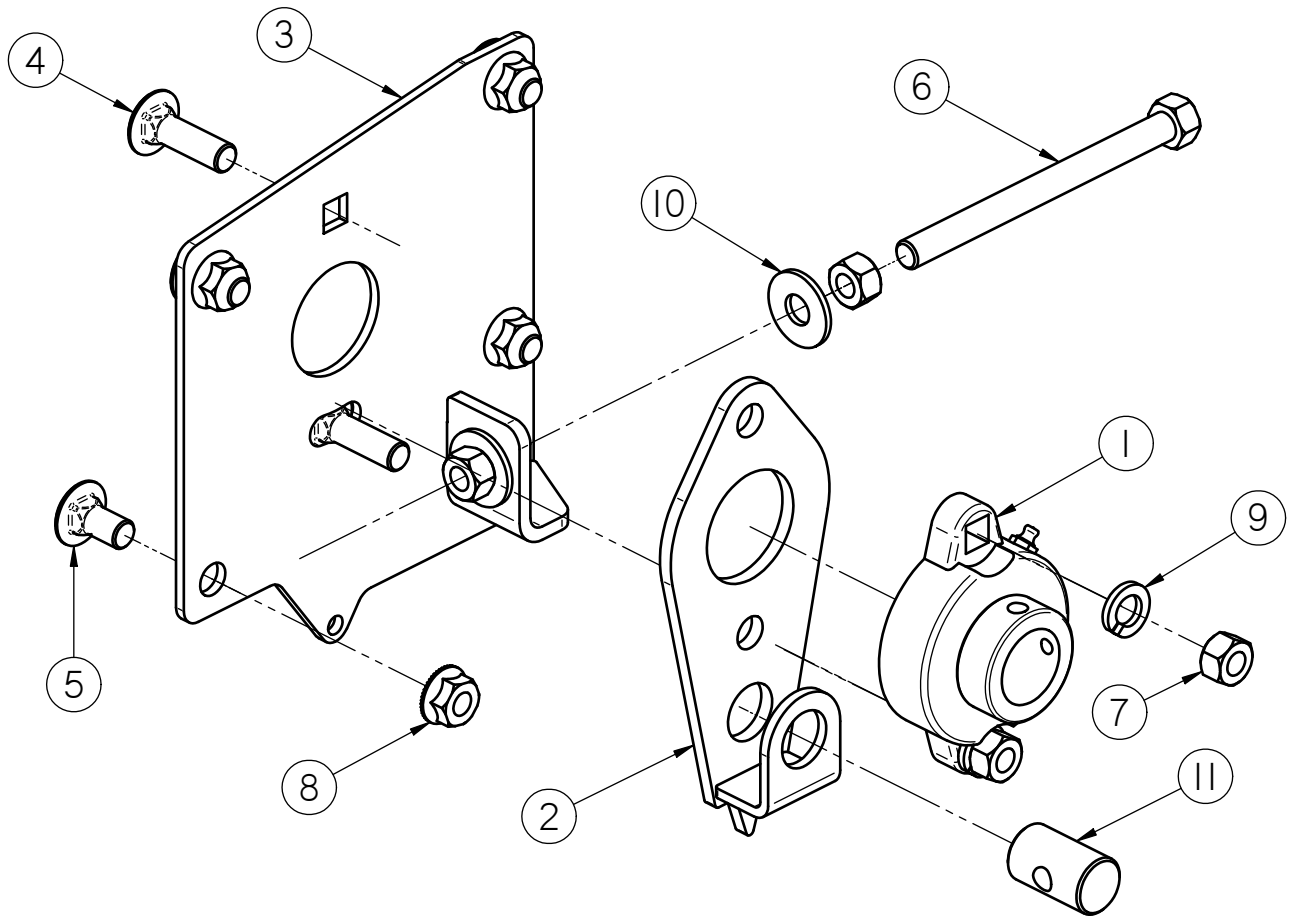

Item #	Part #	Description	Qty
1	01-03-0042	BRG FLG MNT 1.000ID 2BOLT ECNTRC	1
2	05-08-0484	WDMT TRACKING PIVOT	1
3	05-08-0494	WDMT TRACKING PLT HD	1
4	06-01-0127	BOLT CRG .375-16 X 1.25 ZP GR5	2
5	06-01-0153	BOLT CRG .375-16X.750 ZP SHORT NECK	4
6	06-01-0247	BOLT .375-16X4.5 HH G5 ZP FTH	1
7	06-02-0003	NUT FULL .375-16 ZP GR5	4
8	06-03-0014	NUT LOCK FLG .375-16 ZP GR5	4
9	06-04-0003	WSHR LOCK SPLT .375 ZP	2
10	06-05-0004	WSHR FLAT .375 ZP	2
11	104079	PIN TRACKING PIVOT	1

TRANSITION TRACKING PLATE ASSEMBLY (13-08-0559)

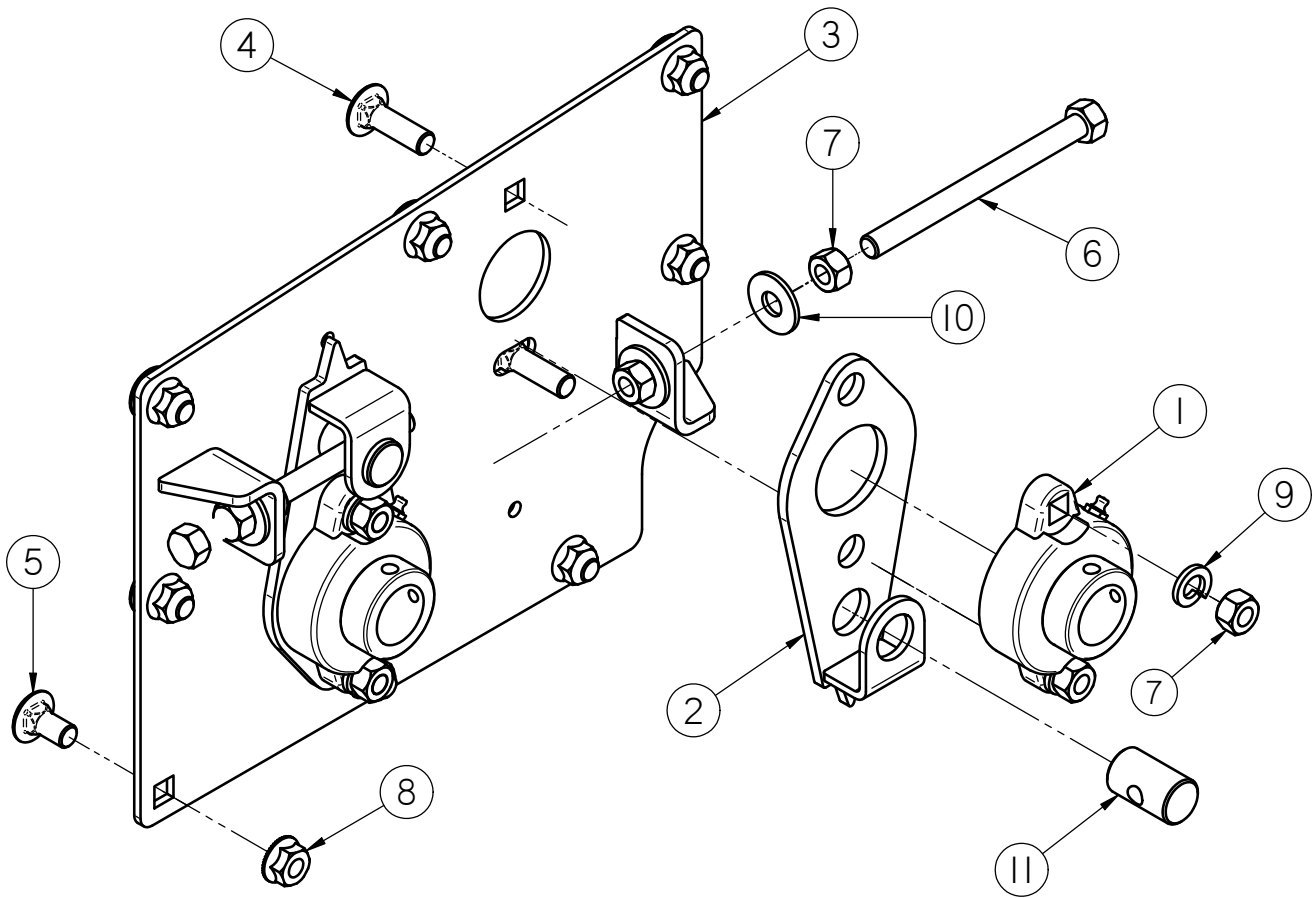

Item #	Part #	Description	Qty
1	01-03-0042	BRG FLG MNT 1.000ID 2BOLT ECNTRC	2
2	05-08-0484	WDMT TRACKING PIVOT	2
3	05-08-0485	WDMT PLT TRACKING	1
4	06-01-0127	BOLT CRG .375-16 X 1.25 ZP GR5	4
5	06-01-0153	BOLT CRG .375-16X.750 ZP SHORT NECK	8
6	06-01-0247	BOLT .375-16X4.5 HH G5 ZP FTH	2
7	06-02-0003	NUT FULL .375-16 ZP GR5	8
8	06-03-0014	NUT LOCK FLG .375-16 ZP GR5	8
9	06-04-0003	WSHR LOCK SPLT .375 ZP	4
10	06-05-0004	WSHR FLAT .375 ZP	4
11	104079	PIN TRACKING PIVOT	2

TS3500 TRUCK UNLOAD CONVEYOR
WHEEL AND AXLE ASSEMBLY (13-08-0565)

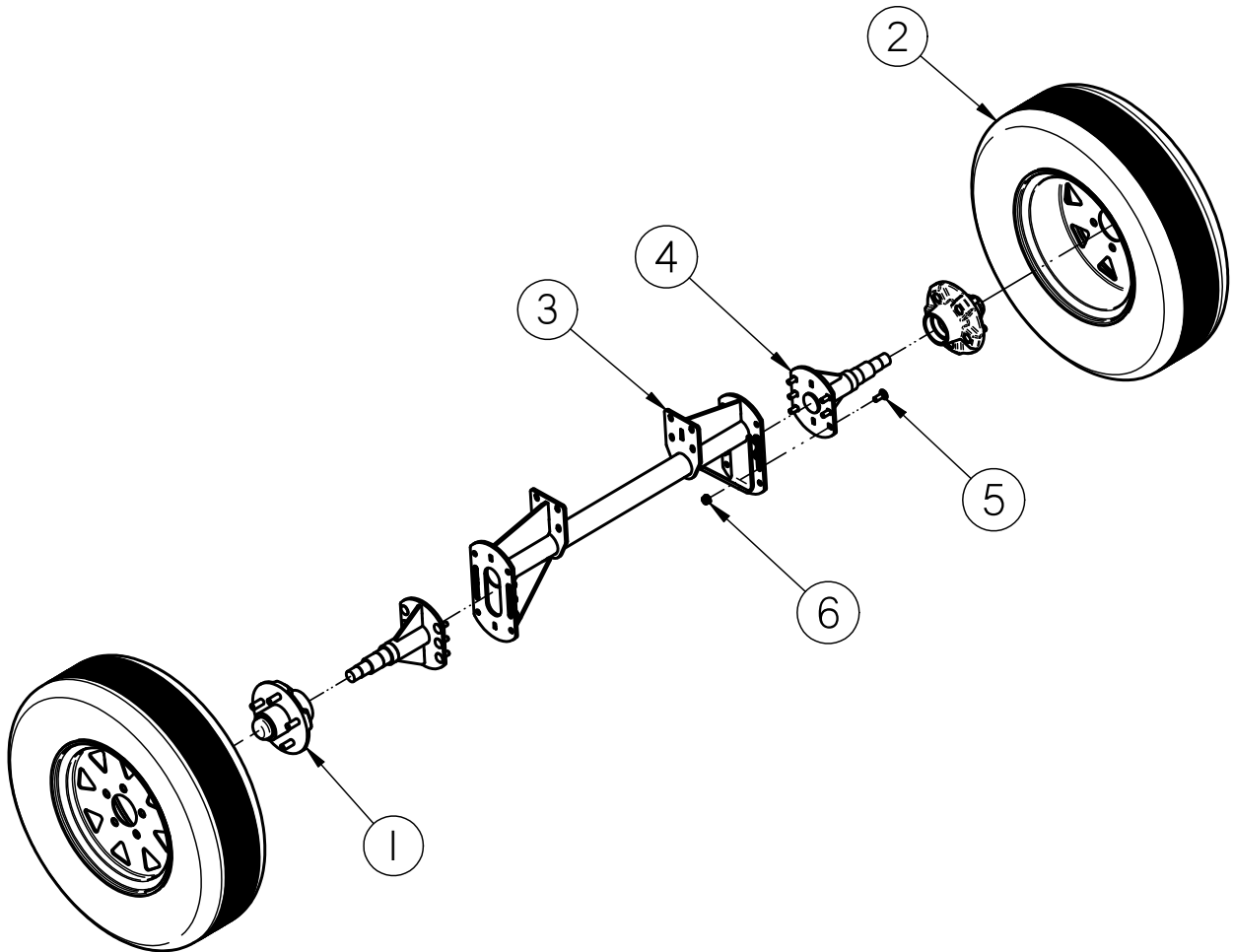

Item #	Part #	Description	Qty
1	01-06-0053	HUB 5 ON 4.5IN CTR	2
2	01-06-0150	ASSY WHL/TIRE 5BLT-15.0 X 6.0 6PLY	2
3	05-08-0497	WDMT AXLE	1
4	05-08-0521	WDMT AXLE STUB TRK UNLND	2
5	06-01-0115	BOLT CRG .375-16 X 1.00 ZP GR5	12
6	06-03-0014	NUT LOCK FLG .375-16 ZP GR5	12

TS3500 TRUCK UNLOAD CONVEYOR
COLAPSABLE HOPPER ASSEMBLY (13-08-0557)

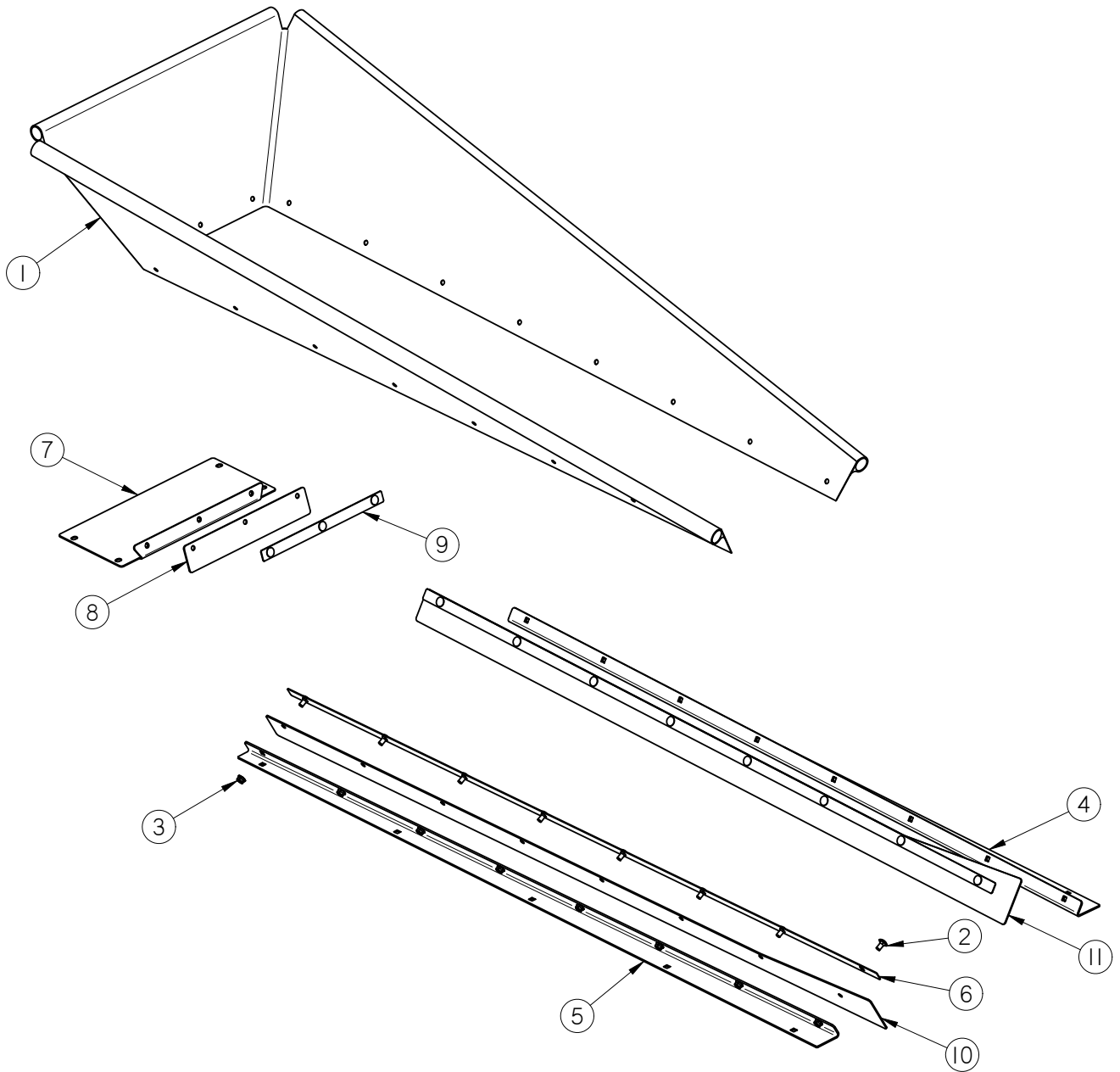

COLAPSABLE HOPPER ASSEMBLY (13-08-0557)

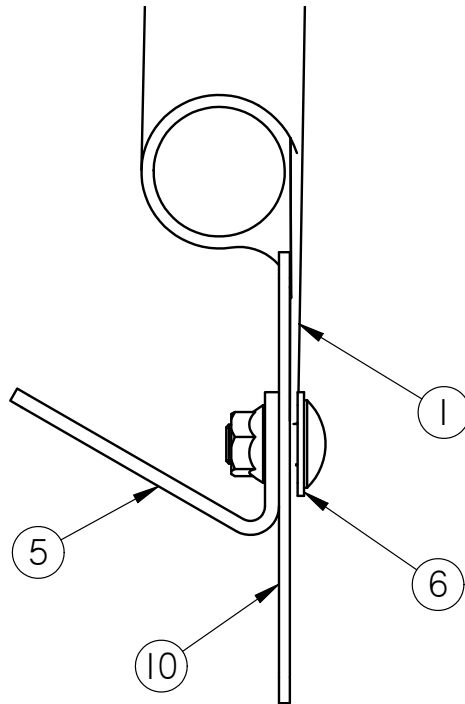

PARTS ASSEMBLY ORDER

- 6. 1040D3 - PLT CLMP SKIRT
- 1. 01-13-0020 - TARP
- 10. 1053E5 - SKIRT RBBR RH
- 5. 1040D1 - PLT TARP MNT RH

Item #	Part #	Description	Qty
1	01-13-0020	TARP CLPSBL TR UNLD	1
2	06-01-0153	BOLT CRG .375-16X.750 ZP SHORT NECK	19
3	06-03-0014	NUT LOCK FLG .375-16 ZP GR5	19
4	1040D0	PLT TARP MNT LH	1
5	1040D1	PLT TARP MNT RH	1
6	1040D3	PLT CLMP SKIRT	2
7	1040D4	PLT TOP SEAL MNT	1
8	1040D5	SKIRT RBBR REAR	1
9	1040D6	PLT CLMP SKIRT REAR	1
10	1053E5	SKIRT RBBR RH	1
11	1053FC	SKIRT RBBR LH	1

BASE ASSEMBLY (13-08-0570)

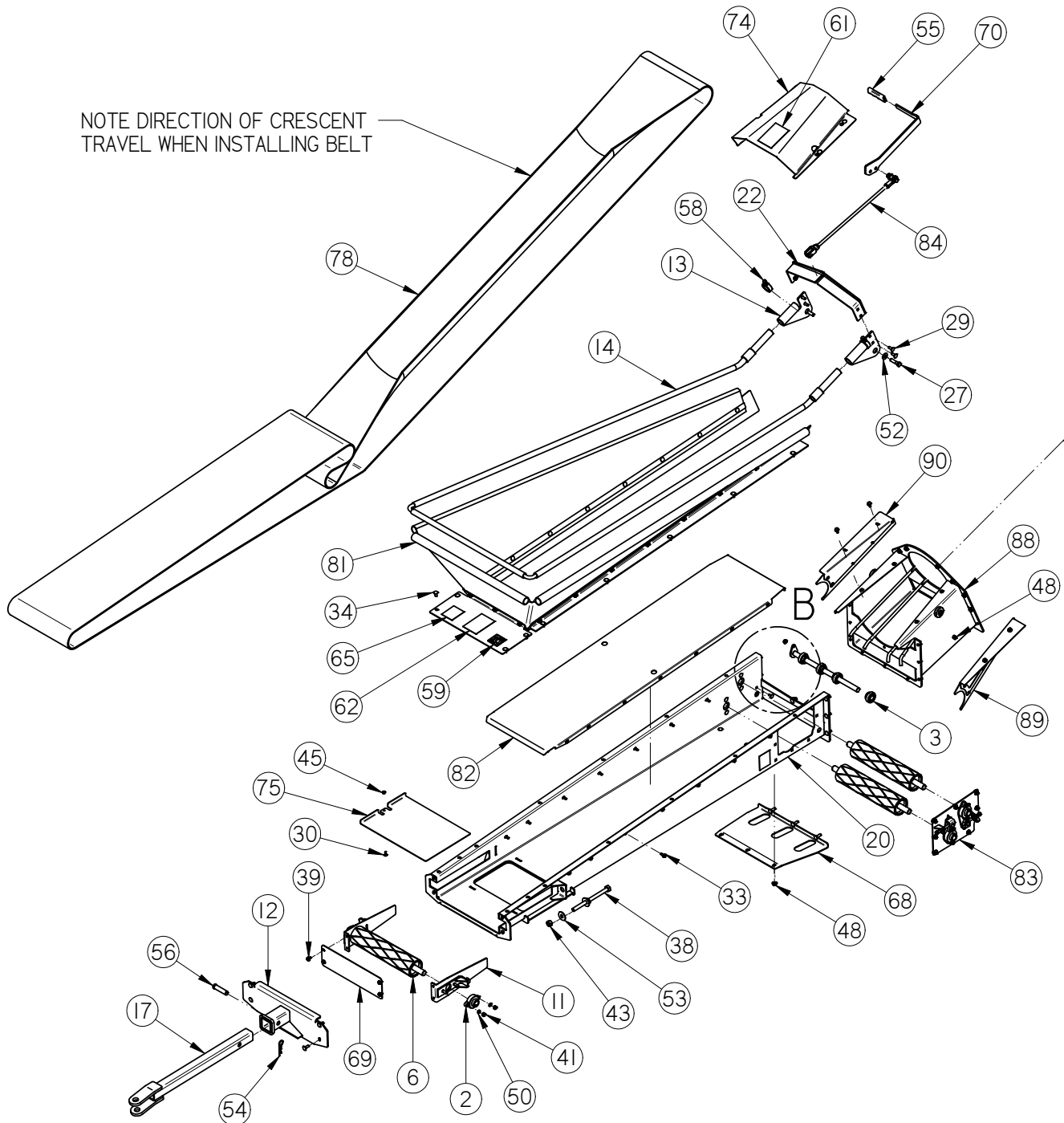

TS3500 TRUCK UNLOAD CONVEYOR

BASE ASSEMBLY (13-08-0570)

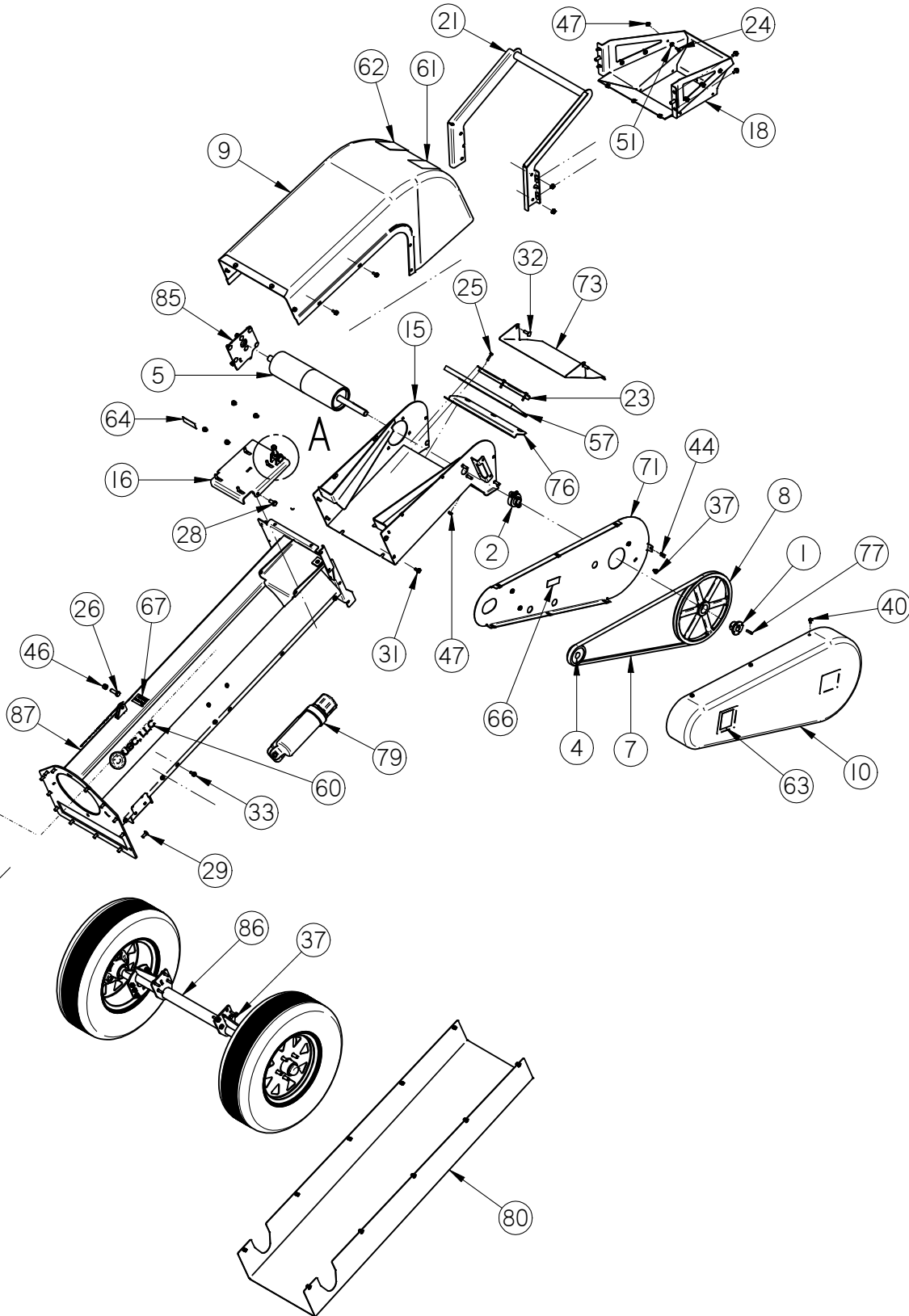

BASE ASSEMBLY (13-08-0570)

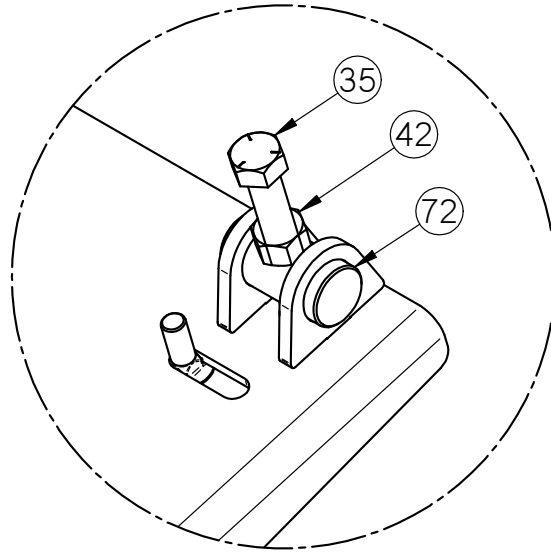

DETAIL A

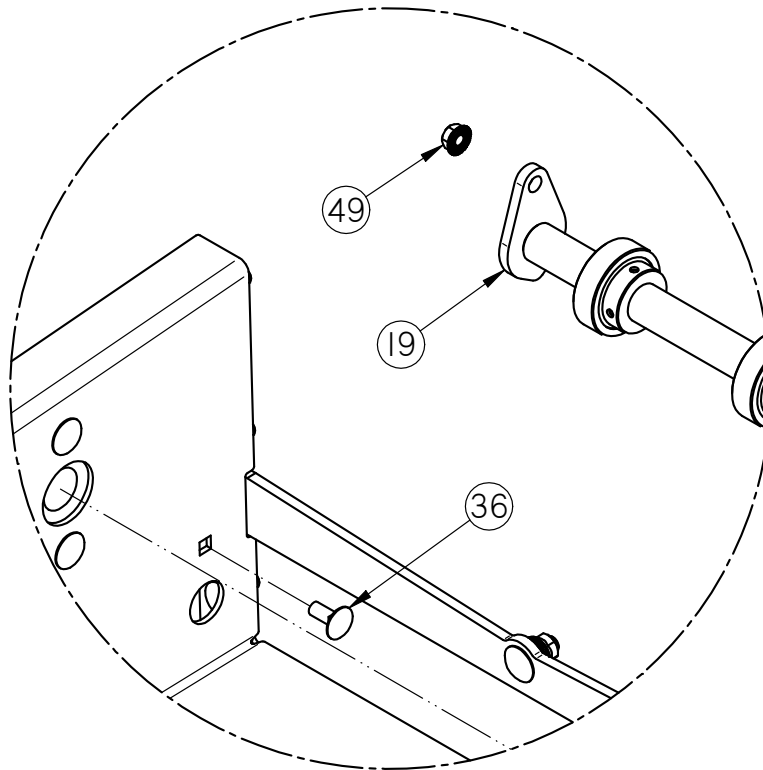

DETAIL B

TS3500 TRUCK UNLOAD CONVEYOR

BASE ASSEMBLY (13-08-0570)

Item #	Part #	Description	Qty
1	01-02-0060	BUSH 1.000IN BORE TYPE H	1
2	01-03-0042	BRG FLG MNT 1.000ID 2BOLT ECNTRC	5
3	01-03-0073	BRG BALL .875ID X .2.047OD	4
4	01-08-0063	SHV BK36 1.125 FHSB BORE	1
5	01-08-0096	PULLEY HEAD VULC S2000	1
6	01-08-0113	PULLEY TR UNLD TREADED	3
7	01-08-0115	BELT BX90	1
8	01-08-0116	SHEAVE BK140H	1
9	05-06-0115	COVER HEAD TR UNLD	1
10	05-06-0116	CVR BELT DRV	1
11	05-08-0483	WDMT TAKE-UP PLT TR UNLD	2
12	05-08-0486	WDMT HITCH TR UNLD	1
13	05-08-0487	WDMT CLPSBL PIVOT	2
14	05-08-0488	WDMT FRAME TARP	1
15	05-08-0492	WDMT DISCHARGE HD	1
16	05-08-0493	WDMT MTR MNT PLT	1
17	05-08-0498	WDMT HITCH TUBE	1
18	05-08-0551	WDMT DSCHG HD SPOUT TS35	1
19	05-08-0559	WDMT PIN ROLLER	1
20	05-08-0662	WDMT FRAME BASE W/ CL-OUT	1
21	05-08-0700	WDMT HANDLE TR UNLD	1
22	05-08-0701	WDMT TARP LIFT	1
23	05-10-2138	INLET BRSH HLDR S2000	1
24	06-01-0006	BOLT .250-20 X .750 ZP GR5	6
25	06-01-0008	BOLT, .250-20 X 1 1/4" UNC ZP GRADE 5	3
26	06-01-0025	BOLT .500-13 X 1.50 ZP GR5	1
27	06-01-0027	BOLT .500-13 X 2.00 ZP GR5	2
28	06-01-0069	BOLT .500-13 X 1.00 ZP GR5	2
29	06-01-0115	BOLT CRG .375-16 X 1.00 ZP GR5	32
30	06-01-0122	BOLT, CARRIAGE, .250-20x.75 G5 ZP	1
31	06-01-0124	BOLT FLG .375-16 X .750 ZP GR5	8
32	06-01-0127	BOLT CRG .375-16 X 1.25 ZP GR5	13
33	06-01-0138	BOLT, FLG .3125-18 UNC ZP GRADE 5; 3/4" LG	38
34	06-01-0153	BOLT CRG .375-16X.750 ZP SHORT NECK	20
35	06-01-0157	BOLT, .500-13 X 4" UNC ZP GRADE 5 fth	1

TS3500 TRUCK UNLOAD CONVEYOR

BASE ASSEMBLY (13-08-0570)

Item #	Part #	Description	Qty
36	06-01-0171	BOLT CRG .3125-18X.750 ZP SHORT NECK	1
37	06-01-0189	BOLT FLG .375-16 X 1.250 ZP GR5	8
38	06-01-0249	BOLT .625-11 X 9.00 ZP GR5 FTH	2
39	06-01-0261	BOLT FLG .3125-18 X .500 ZP GR5	8
40	06-01-0299	BOLT FLG .250-20 X .500 ZP GR5	7
41	06-02-0003	NUT FULL .375-16 ZP GR5	10
42	06-02-0004	NUT FULL .500-13 ZP GR5	1
43	06-02-0005	NUT, .625-11 UNC ZP GRADE 5	4
44	06-02-0047	NUT .250-20 U-CLIP NUT	7
45	06-03-0001	NUT,LOCK, .250-20 ZP G5 NYLON INSERT	1
46	06-03-0004	NUT NYL LOCK .500-13 ZP GR5	5
47	06-03-0013	NUT,LOCK, FLG .250-20 ZP SERRATED	9
48	06-03-0014	NUT LOCK FLG .375-16 ZP GR5	67
49	06-03-0019	NUT LOCK FLG .3125-18 ZP GR5	1
50	06-04-0003	WSHR LOCK SPLT .375 ZP	10
51	06-05-0001	WASHER, FLAT .250	6
52	06-05-0005	WSHR FLAT .500 ZP	2
53	06-05-0006	WASHER, .625 FLAT ZP	4
54	06-09-0039	PIN CLIP HITCH 2.625 #11 1/8 IN ZP	1
55	06-09-0085	CLPSBL HOPP HNDL GRIP	1
56	06-09-0095	PIN CLVS .750 X 3.00 ZP	1
57	06-10-0051	BRUSH SEAL 16.5"L	1
58	06-12-0049	COLLAR SET 2"OD X 1 1/4"ID	2
59	09-01-0003	ATWK LBL MADE IN USA YEL 2.50X2.50	1
60	09-01-0042	ATWL LBL USC, LLC 3" X 15" PRO-CUT	2
61	09-02-0001	ATWK LBL DANGER FINGERS	2
62	09-02-0002	ATWK LBL DANGER GUARDS	2
63	09-02-0009	ATWK LBL WARNING ROTATING PARTS	1
64	09-02-0010	ATWK LBL DANGER ELECTROCUTION	1
65	09-02-0011	ATWK LBL WARNING MOVING PARTS	4
66	09-02-0012	ATWK LBL DANGER MISSING SHIELD	1
67	09-02-0015	ATWRK LBL DANGER PINCH POINT	1
68	104083	PLT BASE SKID	1
69	10408B	PLT TAKE-UP CVR	1
70	10408C	PLT LEVER	1

TS3500 TRUCK UNLOAD CONVEYOR

BASE ASSEMBLY (13-08-0570)

Item #	Part #	Description	Qty
71	104139	BACKPLATE BELT COVER	1
72	10414A	PIN MTR PIVOT	1
73	1041CF	PLT SEED DEFLECTOR	1
74	104B60	CVR SEED FLOW	1
75	1053E6	PLT DOOR CLEAN-OUT	1
76	1055E6	PLT FILLER HD ATTACH	1
77	106-3-2036	KEY .250 X 1.25 CS	1
78	11-02-0162	BELT TR UNLD	1
79	13-05-0332	ASSY MANUAL TUBE MT	1
80	13-08-0556	ASSY FRAME W-RIVET NUTS	1
81	13-08-0557	ASSY CLPSBL TR UNLD	1
82	13-08-0558	ASSY PAN BELT SUPPORT	1
83	13-08-0559	ASSY TRACKING PLT	1
84	13-08-0563	ASSY LINK TARP LIFT	1
85	13-08-0564	ASSY TRACKING PLT HD	1
86	13-08-0565	ASSY AXLE W-WHEELS	1
87	13-08-0568	ASSY TUBE WDMT W-RIVET NUTS	1
88	13-08-0647	ASSY FRAME W-RIVET NUTS	1
89	13-08-0648	ASSY SEED GUIDE RH	1
90	13-08-0649	ASSY SEED GUIDE LH	1

TS3500 TRUCK UNLOAD CONVEYOR

TOP ASSEMBLY

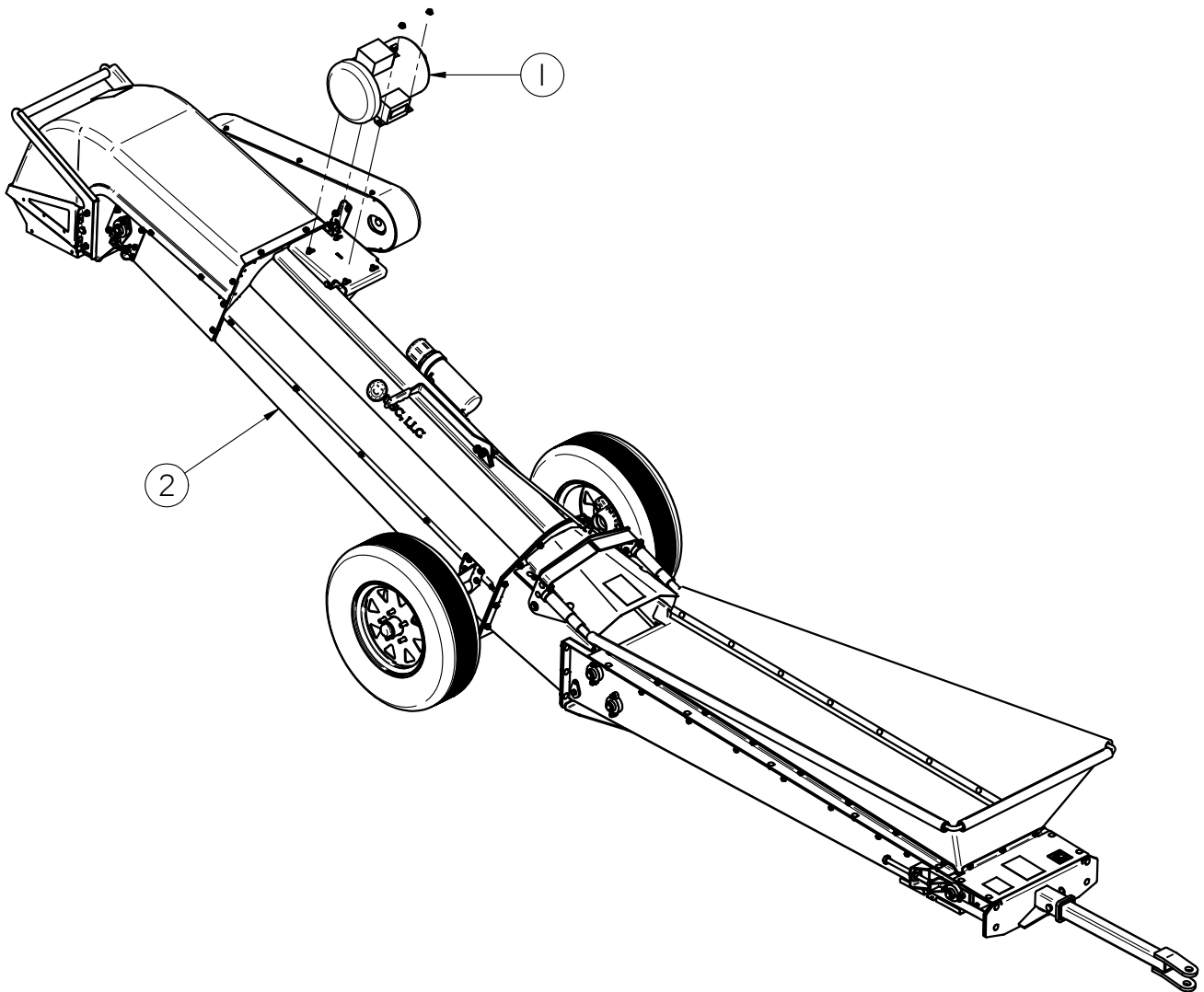

Item #	Part #	Description	Qty
1	SEE TABLE 1	5HP MOTOR	1
2	13-08-0570	ASSY TS35 TRK UNLD BASE	1

TABLE 1		
Assembly #	Part #	Description
17-05-0022	01-01-0107	MOTOR 5HP 1750RPM 184T TEFC 115/230V 1PH
17-05-0023	01-01-0151	MOTOR 5HP 1760RPM 184T TEFC 230/460V 3PH
17-05-0024	01-01-0209	MOTOR 5HP 1425RPM 184T TEFC 380V 3PH
17-05-0025	01-01-0143	MOTOR 5HP 1760RPM 184T TEFC 575V 3PH

USC LIMITED WARRANTY

SECTION H

USC, LLC, (Manufacturer) warrants its seed treating equipment as follows:

1. **Limited Warranty:** Manufacturer warrants that the Products sold hereunder will be free from defects in material and workmanship for a period of 18 months from date of shipment. If the Products do not conform to this Limited Warranty during the warranty period, Buyer shall notify Manufacturer in writing of the claimed defects and demonstrate to Manufacturer satisfaction that said defects are covered by this Limited Warranty. If the defects are properly reported to Manufacturer within the warranty period, and the defects are of such type and nature as to be covered by this warranty, Manufacturer shall, at its expense, furnish replacement Products or, at Manufacturer's option, replacement parts for the defective products. Shipping and installation of the replacement Products or replacement parts shall be at the Buyer's expense.

2. **Other Limits:** THE FOREGOING IS IN LIEU OF ALL OTHER WARRANTIES, EXPRESSED OR IMPLIED, INCLUDING BUT NOT LIMITED TO THE IMPLIED WARRANTIES OF MERCHANTABILITY AND FITNESS FOR A PARTICULAR PURPOSE. Manufacturer does not warrant against damages or defects arising from improper installation (where installation is by persons other than Manufacturer), against defects in products or components not manufactured by Manufacturer, or against damages resulting from such non-Manufacturer made products or components. Manufacturer passes on to the Buyer the warranty it received (if any) from the maker of such non-Manufacturer made products or components. This warranty also does not apply to Products upon which repairs and / or modifications have been effected or attempted by persons other than pursuant to written authorization by Manufacturer. This includes any welding on equipment which could damage electrical components. Manufacturer does not warrant against casualties or damages resulting from misuse and / or abuse of Products, improper storage or handling, acts of nature, effects of weather, including effects of weather due to outside storage, accidents, or damages incurred during transportation by common carrier.

3. **Exclusive Obligation:** THIS WARRANTY IS EXCLUSIVE. The sole and exclusive obligation of Manufacturer shall be to repair or replace the defective Products in the manner and for the period provided above. Manufacturer shall not have any other obligation with respect to the Products or any part thereof, whether based on contract, tort, strict liability or otherwise. Under no circumstances, whether based on this Limited Warranty or otherwise, shall Manufacturer be liable for lost profits, lost revenue, lost sales (whether direct or indirect damages), incidental, special, punitive, indirect or consequential damages.

4. **Other Statements:** Manufacturer's employees or representatives' oral or other written statements do not constitute warranties, shall not be relied upon by Buyer, and are not a part of the contract for sale or this limited warranty.

5. **Return Policy:** Approval is required prior to returning goods to Manufacturer. A restocking fee will apply.

6. **Entire Obligation:** This Limited Warranty states the entire obligation of Manufacturer with respect to the Products. If any part of this Limited Warranty is determined to be void or illegal, the remainder shall remain in full force and effect.

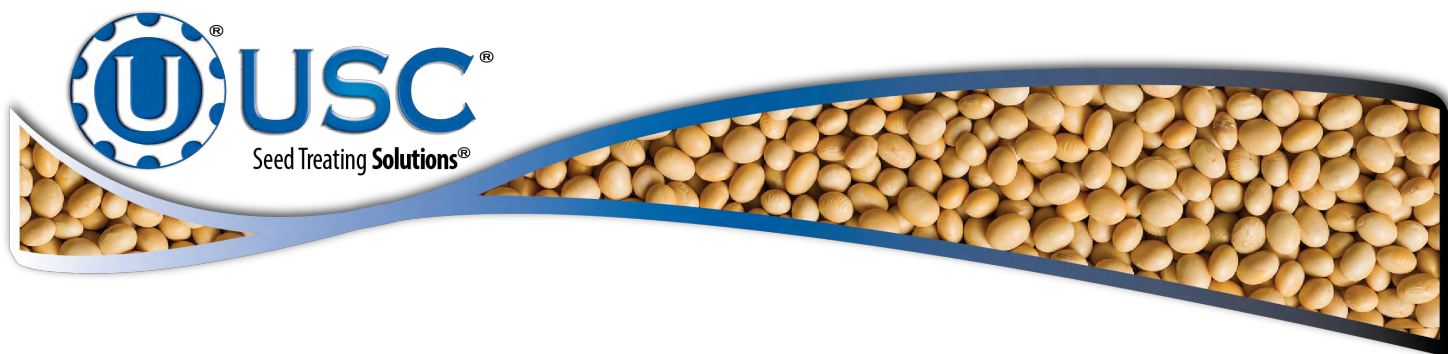

USC, LLC

2320 124th road

Sabetha, KS 66534

PHONE: (785) 431-7900

FAX: (785) 431-7950

EMAIL: sales-team@uscllc.com

WEB: www.uscllc.com

