

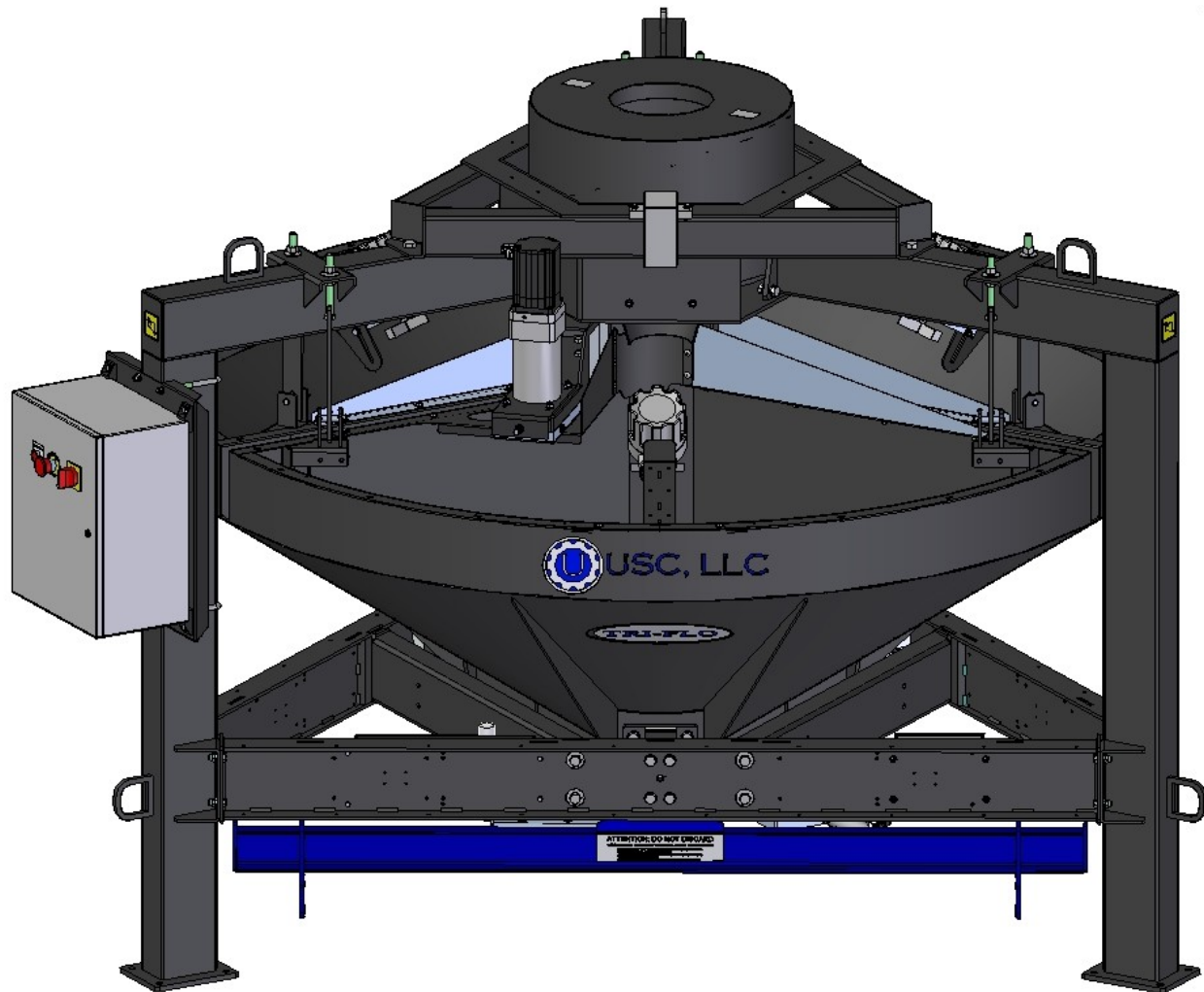

# **TRI-FLO** <sup>®</sup>

## **Seed Wheel with Servo**

### **Operators Manual**



**Document: TD-09-06-1039**

**Revision: B**



## **INTRODUCTION**

Thank you for choosing USC, LLC for your equipment needs. We appreciate your business and will work diligently to ensure that you are satisfied with your choice.

### **OVERVIEW**

The purpose of this manual is to provide you with the basic information needed to operate and maintain the Tri - Flo ® System. It does not hold USC, LLC liable for any accidents or injuries that may occur.

The technical information provided in this document is based on extensive testing under controlled conditions at the USC research and development facility. This information is given without guarantee as the conditions of operation and storage of the equipment are beyond our control. Variables such as temperature, humidity, viscosity of chemical products and changes in seed size or variety may all effect the accuracy of application and seed coverage. Periodically check the equipment calibration while treating and make adjustments as required. This will insure the optimum seed coverage.

### **OPERATOR RESPONSIBILITIES**

As the purchaser/owner/operator of this equipment and control system, you have an obligation to install, operate, and maintain the equipment in a manner that minimizes the exposure of people in your care to any potential hazards inherent in using this equipment. It is critical that the owner of this equipment:

- Has a clear and documented understanding of the process this machine is being used in and of any resulting hazards or special requirements arising from this specific application.
- Allow only properly trained and instructed personnel to install, operate or service this equipment.
- Maintain a comprehensive safety program involving all who work with this machine and other associated process equipment.
- Establish clear areas of staff responsibility (e.g. operation, setup, sanitation, maintenance, and repairs).
- Provide all personnel with necessary safety equipment.
- Periodically inspect the equipment to insure that the doors, covers, guards, and safety devices are in place and functioning, that all safety instructions and warning labels are intact and legible, and that the equipment is in good working order.
- In addition to the operating instructions, observe and enforce the applicable legal and other binding regulations, national and local codes.

As the person with the most to gain or lose from working safely, it is important that you work responsibly and stay alert. By following a few simple rules, you can prevent an accident that could injure or kill you or a co-worker.

- Disconnect, lockout, and tagout electrical and all other energy sources before inspecting, cleaning, servicing, repairing, or any other activity that would expose you to the hazards of electrical shock.
- Do not operate, clean, or service this equipment until you have read and understood the contents of this manual. If you do not understand the information in this manual, bring it to the attention of your supervisor, or call USC at (785) 431-7900 for assistance.
- Any operator who is known or suspected to be under the influence of alcohol or drugs should not be allowed to operate the equipment.
- Understand and follow the safety practices required by your employer and this manual.
- **PAY ATTENTION** to what you and other personnel are doing and how these activities may affect your safety.
- **Failure to follow these instructions may result in serious personal injury or death.**

### RECEIVING YOUR EQUIPMENT

As soon as the equipment is received, it should be carefully inspected to make certain that it has sustained no damage during shipment and that all items listed on the packing list are accounted for. If there is any damage or shortages, the purchaser must immediately notify USC, LLC. Ownership passes to purchaser when the unit leaves the USC, LLC. premises. The purchaser is responsible for unloading and mounting all components of the equipment.

Document the serial number of the machine for future reference. The serialization label is located on the left side of the frame cross member under the number one hopper.



**Tri - Flo ®  
Serial Number**

**SERIAL NUMBER:** \_\_\_\_\_

# TABLE OF CONTENTS

<b><u>Section</u></b>	<b><u>Contents</u></b>	<b><u>Page #</u></b>
<b>Section A</b>	<b>Safety Instructions .....</b>	<b>5</b>
	C2D2 Specifications and Labels (Version 3 Only).....	18
<b>Section B</b>	<b>Installation .....</b>	<b>19</b>
<b>Section C</b>	<b>Mechanical Operation .....</b>	<b>30</b>
	Tri - Flo ® System Overview .....	30
	Bin Site System Overview .....	32
	Bin Slide Gates, Underbin Conveyor, Pro Box Hopper .....	34
	Underbin Conveyor Encoder, Transfer Conveyor .....	34
	Tri - Flo ® Weigh Hopper, Slide Gate & Scale Head .....	35
	Scale Fill Conveyor, Diverter .....	35
<b>Section D</b>	<b>Electrical Operation .....</b>	<b>36</b>
<b>Section E</b>	<b>Troubleshooting .....</b>	<b>38</b>
	Unplugging Conveyors .....	41
<b>Section F</b>	<b>Maintenance .....</b>	<b>42</b>
<b>Section G</b>	<b>Belt Tensioning Specification .....</b>	<b>52</b>
<b>Section H</b>	<b>Storage.....</b>	<b>53</b>
<b>Section I</b>	<b>Mechanical Drawings.....</b>	<b>55</b>
<b>Section J</b>	<b>Limited Warranty.....</b>	<b>113</b>



# SAFETY INSTRUCTIONS

## SECTION A

Every year accidents in the work place maim, kill and injure people. Although it may be impossible to prevent all accidents, with the right combination of training, operating practices, safety devices, and operator vigilance, the number of accidents can be significantly reduced. The purpose of this section is to educate equipment users about hazards, unsafe practices, and recommended hazard avoidance techniques.

If any of the required regularly scheduled maintenance is located above the reach of the operator, they should follow the companies normal safe practices of reaching that particular height, utilizing the companies specified equipment and following normal safety precautions.

When working with treatment chemicals, operators should always wear protective gloves, safety glasses, and follow the companies safety precautions in the case of any spillage or operator contamination.

### **SAFETY WORDS AND SYMBOLS**

It is very important that operators and maintenance personnel understand the words and symbols that are used to communicate safety information. Safety words, their meaning and format, have been standardized for U.S. manufacturers and published by the American National Standards Institute (ANSI). The European Community (ETC.) has adopted a different format based on the International Standards Organization (I.E.) and applicable machinery directives. Both formats are presented below. Graphic symbols are not standardized, but most manufacturers will use some variation of the ones seen in this manual.

### **MOTS ET SYMBOLES SECURITY**

Il Est très important que les opérateurs et le personnel d'entretien à comprendre les mots et les symboles qui sont utilisés pour communiquer des informations de sécurité. Mots de sécurité, de leur signification et le format, ont été normalisés pour les fabricants américains et publié par l' American National Standards Institute ( ANSI ). La Communauté européenne (CE ) a adopté un format différent sur la base de l'Organisation internationale de normalisation ( ISO ) et des directives de machines applicables. Les deux formats sont présentés ci-dessous. Les symboles graphiques ne sont pas standardisés, mais la plupart des fabricants utilisent une variante de ceux observés dans ce manuel.



Indicates an imminently hazardous situation which, if not avoided, **will** result in death or serious injury.



Indique une situation extrêmement dangereuse qui, si pas évitée, entraînera la mort ou des blessures graves.



Indicates a potentially hazardous situation which, if not avoided, **could** result in death or serious injury.



Indique une situation potentiellement dangereuse qui, si pas évitée, pourrait entraîner la mort ou des blessures graves.



Indicates a potentially hazardous situation which, if not avoided, **may** result in minor or moderate injury and/or property damage.



Indique une situation potentiellement dangereuse qui, si pas évitée, peut entraîner des blessures mineures ou modérées et / ou des dommages.



Provides additional information that the operator needs to be aware of to avoid a potentially hazardous situation.



Fournit des informations supplémentaires que l'opérateur doit être conscient de d'éviter une situation potentiellement dangereuse.



Notice is used to notify people of important installation, operation or maintenance information which is not hazard related.



Avis Est utilisé pour informer les gens des informations de maintenance qui ne Est pas danger lié importante installation, l'exploitation ou.



**Mandatory Lockout Power Symbol.** Disconnect, lockout and tagout electrical and other energy sources before inspecting, cleaning or performing maintenance on this panel.

**Symbole de puissance verrouillage obligatoire.** Débranchez, de verrouillage et de désignation énergie électrique et d'autres sources avant d'inspecter, de nettoyage ou de la maintenance de ce panneau.



**International Safety Alert Symbol.** The exclamation point (!) surrounded by a yellow triangle indicates that an injury hazard exists. However, it does not indicate the seriousness of potential injury. The exclamation point (!) is also used with the DANGER, WARNING and CAUTION symbols so the potential injury is indicated.

**Sécurité Symbole International Alert .** Le point d'exclamation ( ! ) Entouré par un triangle jaune indique que un risque de blessure existe . Cependant, il ne indique pas la gravité des blessures potentielles. Le point d'exclamation ( ! ) Est également utilisé avec les symboles DANGER, AVERTISSEMENT et ATTENTION de sorte que le risque de blessure Est indiqué.



**Electrocution Hazard Symbol.** This symbol indicates that an electrocution hazard exists. Serious injury or death could result from contacting high voltage.

**Symbole de danger d'électrocution .** Ce symbole indique qu'un danger d'électrocution existe. Des blessures graves ou la mort pourraient résulter de contact haute tension.



**International Electrocution Hazard.** This symbol indicates that an electrocution hazard exists. Serious injury or death could result from contacting high voltage.

**Danger d'électrocution international.** Ce symbole indique qu'un danger d'électrocution existe. Des blessures graves ou la mort pourraient résulter de contact haute tension.



**Mandatory Read Manual Action Symbol.** (I.E. format) This symbol instructs personnel to read the Operators Manual before servicing or operating the equipment.

**Obligatoire Lire Symbole d'action Manuel.** ( Format ISO )  
Ce symbole indique le personnel de lire le manuel de l'opérateur avant de réparer ou d'utiliser l'équipement.



**Mandatory Read Manual Action Symbol.** This symbol instructs personnel to read the Operators Manual before servicing or operating the equipment.

**Obligatoire Lire Symbole d'action Manuel .** Ce symbole indique le personnel de lire le manuel de l'opérateur avant de réparer ou d'utiliser l'équipement.

## **LOCKOUT / TAGOUT PROCEDURES**

Lockout/Tagout is the placement of a lock/tag on an energy isolating device in accordance with an established procedure. When taking equipment out of service to perform maintenance or repair work, always follow the lockout / tagout procedures as outlined in ANSI Z344.1 and/or OSHA Standard 1910.147. This standard “requires employers to establish a program and utilize procedures for affixing appropriate lockout devices or tagout devices to energy isolating devices and to otherwise disable machines or equipment to prevent unexpected energizing, start-up, or release of stored energy in order to prevent injury to employees.”

## **LES PROCEDURES DE VERROUILLAGE / ETIQUETAGE**

Verrouillage / étiquetage Est le placement d'un verrouillage / tag sur un dispositif d'isolement de l'énergie conformément à une procédure établie. Lors de la prise hors service des équipements pour effectuer la maintenance ou de réparation, toujours suivre les procédures de verrouillage / débranchement comme indiqué dans la norme ANSI Z344.1 et / ou la norme OSHA 1910.147. Cette norme "oblige les employeurs à établir un programme et appliquer des procédures pour la fixation des dispositifs de verrouillage appropriés ou des dispositifs déconsignation à l'énergie dispositifs d'isolement et d' autre machines ou équipements désactiver pour éviter énergisant inattendu, start-up, ou la libération de l'énergie stockée dans le but de prévenir les blessures aux employés."

## **EMERGENCY STOP**



There is an Emergency Stop push button on all LPV Seed Treaters which is located on the Treater Control Panel. The LPV Automated Treater has an additional Emergency Stop pushbutton on the Main Control Panel. Actuators of emergency stop shall be colored RED. The background immediately around the device actuator shall be colored YELLOW. The actuator pushbutton operated device shall be of the palm or mushroom head type.

## **ARRET D'URGENCE**

Il ya un bouton-poussoir d'arrêt d'urgence sur tous les traiteurs de semences LPV qui Est situé sur le Panneau de configuration Traiteur. Le LPV automatisé Traiteur dispose d'une autre arrêt d'urgence bouton poussoir sur le panneau de commande principal. Actionneurs de freinage d'urgence doivent être de couleur rouge. Le fond immédiatement autour de l'actionneur de l'appareil doit être de couleur JAUNE. Le dispositif actionné actionneur de bouton-poussoir doit être de la paume ou champignons type de tête.



## **CONTROLLED STOP**

This is the stopping of machine motion by reducing the electrical command signal to 0 (zero) once the stop signal has been recognized.

## **ARRET CONTROLÉ**

Ce Est l' arrêt du mouvement de la machine en réduisant le signal de commande électrique à 0 (zéro ) dès que le signal d'arrêt a été reconnue.

## **HAZARD REVIEW**

### **RISQUE EXAMEN**



### **Electrocution Hazard**

Electrocution accidents are most likely to occur during maintenance of the electrical system or when working on or near exposed high voltage wiring. This hazard does not exist when the electrical power has been disconnected, properly locked, and tagged out.

### **Risque d'électrocution**

Les accidents d'électrocution sont les plus susceptibles de se produire lors de la maintenance du système électrique ou pour travailler sur ou à proximité du câblage haute tension exposé. Ne existe pas ce danger lorsque l'alimentation électrique a été déconnecté, bien verrouillé et étiquetés sur.



**⚠ WARNING**

### **Automatic Start Hazard**

This equipment may be controlled by an automated system and may start without warning. Failure to properly disconnect, lockout, and tagout all energy sources of remotely controlled equipment creates a very hazardous situation and could cause injury or even death. PLEASE STAY CLEAR AND BE ALERT.

### **Démarrer danger automatique**

**! AVERTISSEMENT**

Cet équipement peut être contrôlé par un système automatisé et peut démarrer sans avertissement. Sources de l'équipement contrôlé à distance non débranché correctement, lock-out, et tous déconsignation énergie crée une situation très dangereuse et pourrait causer des blessures ou même la mort. Se IL VOUS PLAÎT rester à l'écart et d'être vigilant.

**YOU** are responsible for the **SAFE** operation and maintenance of your USC, LLC equipment . **YOU** must ensure that you and anyone else who is going to operate, maintain or work around the equipment be familiar with the operating and maintenance procedures and related **SAFETY** information contained in this manual. This manual will take you step-by-step through your working day and alert you to good safety practices that should be adhered to while operating the equipment

Remember, **YOU** are the key to safety. Good safety practices not only protect you, but also the people around you. Make these practices a working part of your safety program. Be certain that **EVERYONE** operating this equipment is familiar with the recommended operating and maintenance procedures and follows all the safety precautions. Most accidents can be prevented. Do not risk injury or death by ignoring good safety practices.

- Equipment owners must give operating instructions to operators or employees before allowing them to operate the machine, and at least annually thereafter per OSHA (Occupational Safety and Health Administration) regulation 1928.57.
- The most important safety device on this equipment is a **SAFE** operator. It is the operator's responsibility to read and understand **ALL** Safety and Operating instructions in the manual and to follow them. All accidents can be avoided.
- A person who has not read and understood all operating and safety instructions is not qualified to operate the machine. An untrained operator exposes himself and bystanders to possible serious injury or death.
- Do not modify the equipment in any way. Unauthorized modification may impair the function and/or safety and could affect the life of the equipment.
- Think SAFETY! Work SAFELY!

### GENERAL SAFETY

1. Read and understand the operator's manual and all safety labels before operating, maintaining, adjusting or unplugging the equipment .
2. Only trained persons shall operate the equipment . An untrained operator is not qualified to operate the machine.
3. Have a first-aid kit available for use should the need arise, and know how to use it.

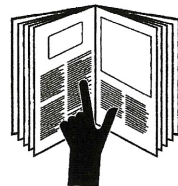

4. Provide a fire extinguisher for use in case of an accident. Store in a highly visible place.
5. Do not allow children, spectators or bystanders within hazard area of machine.
6. Wear appropriate protective gear. This includes but is not limited to:
  - A hard hat
  - Protective shoes with slip resistant soles
  - Protective goggles
  - Heavy gloves
  - Hearing protection
  - Respirator or filter mask
7. Place all controls in neutral or off, stop motor, and wait for all moving parts to stop. Then disable power source before servicing, adjusting, repairing, or unplugging.
8. Review safety related items annually with all personnel who will be operating or maintaining the equipment.

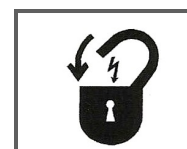

### **OPERATING SAFETY:**

1. Read and understand the Operator's Manual and all safety labels before using.
2. Disconnect and disable electrical supply completely and wait for all moving parts to stop before servicing, adjusting, repairing or unplugging.
3. Clear the area of bystanders, especially children, before starting.
4. Be familiar with the machine hazard area. If anyone enters hazard area, shut down machine immediately. Clear the area before restarting.
5. Keep hands, feet, hair and clothing away from all moving and/or rotating parts.
6. Stay away from overhead obstructions and power lines during operation and transporting. Electrocutation can occur without direct contact.
7. Do not operate machine when any guards are removed.
8. Inspect welds and repair if needed.

**SCALE CERTIFICATION WEIGHT BAR SAFETY:**

1. The scale certification bar has a maximum capacity of 1000 pounds (500 pounds hung from each end).
2. An additional 500 pounds may be added for a total of 1500 pounds but must be suspended from the center of the weight bar. Any additional weight required for certification must be placed inside the hopper.
3. Make sure retaining pin is installed before hanging weights on bar.
4. Slide hanger plates equally from center of bar before adding any weights.
5. When hanging weights on bar, hang weights evenly from side to side.

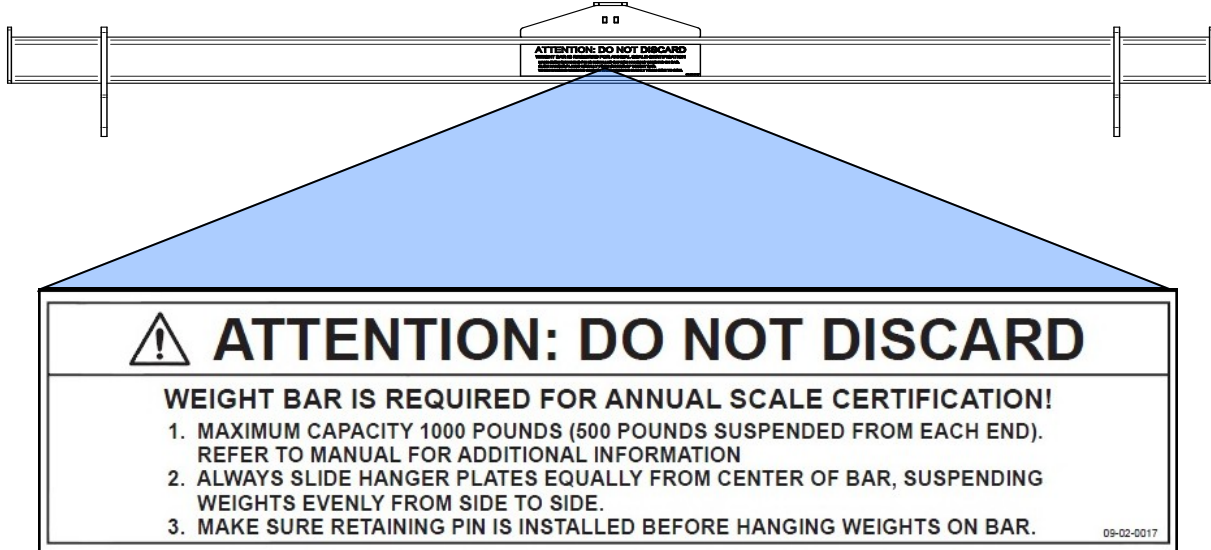

**Label Part # 09-02-0017**

## **PLACEMENT SAFETY**

1. Move only with the appropriate equipment
2. Stay away from overhead power lines when moving equipment. Electrocutation can occur without direct contact.
3. Be familiar with machine hazard area. If anyone enters hazard areas, shut down machine immediately. Clear the area before restarting.
4. Operate the equipment on level ground free of debris. Anchor the equipment to prevent tipping or upending.



Before placement of the equipment, be sure that ground is reasonably level. The equipment may topple or work improperly if the ground is too uneven, damaging the equipment and / or causing personal injury.



Avant de placement de l'équipement, assurez-vous que sol Est relativement plat. L'équipement peut tomber ou mal fonctionner si le sol Est trop inégale, endommager l'équipement et / ou causer des blessures.

## **MAINTENANCE SAFETY**

1. Review the operator's manual and all safety items before working with, maintaining or operating the equipment .
2. Place all controls in neutral or off, stop motors, disable power source, and wait for all moving parts to stop before servicing, adjusting, repairing or unplugging.
3. Follow good shop practices:  
Keep service area clean and dry.  
Be sure electrical outlets and tools are properly grounded.  
Use adequate light for the job at hand.
4. Keep hands, feet, hair and clothing away from all moving and/or rotating parts.
5. Clear the area of bystanders, especially children, when carrying out any maintenance and repairs or making any adjustments.
6. Before resuming work, install and secure all guards when maintenance work is completed.
7. Keep safety labels clean. Replace any sign that is damaged or not clearly visible.





## **SAFETY LABELS**

1. Keep safety labels clean and legible at all times.
2. Replace safety labels that are missing or have become illegible.
3. Replaced parts that displayed a safety label should also display the current label.
4. Replacement safety labels are available. Contact USC at (785) 431-7900 .

### **How to Install Safety Labels:**

- Be sure that the installation area is clean and dry.
- Be sure temperature is above 50°F (10°C).
- Decide on the exact position before you remove the backing paper.
- Remove the smallest portion of the split backing paper.
- Align the sign over the specified area and carefully press the small portion with the exposed sticky backing in place.
- Slowly peel back the remaining paper and carefully smooth the remaining portion of the sign in place.
- Small air pockets can be pierced with a pin and smoothed out using the piece of sign backing paper.



Located on the USC equipment you will find safety labels. Always be sure to read and follow all directions on the labels.



Situé sur l'équipement USC vous trouverez des étiquettes de sécurité. Veuillez à toujours lire et suivre toutes les instructions sur les étiquettes.



Guards provided with USC equipment are to remain in place during operation.



Gardes fournis avec des équipements USC doivent rester en place pendant le fonctionnement.

Think **SAFETY!** Work **SAFELY!**

REMEMBER—If Safety Labels have been damaged, removed, become illegible, or parts replaced without safety labels, new labels must be applied. New safety labels are available from USC at (785) 431-7900.



Part # 09-02-0001



Part # 09-02-0009



Part # 09-02-0002



Part # 09-02-0003

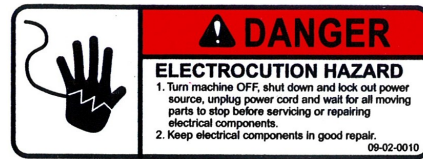

Part # 09-02-0010

(TOP OF DISTRIBUTION ASSEMBLY - 2 PLACES)

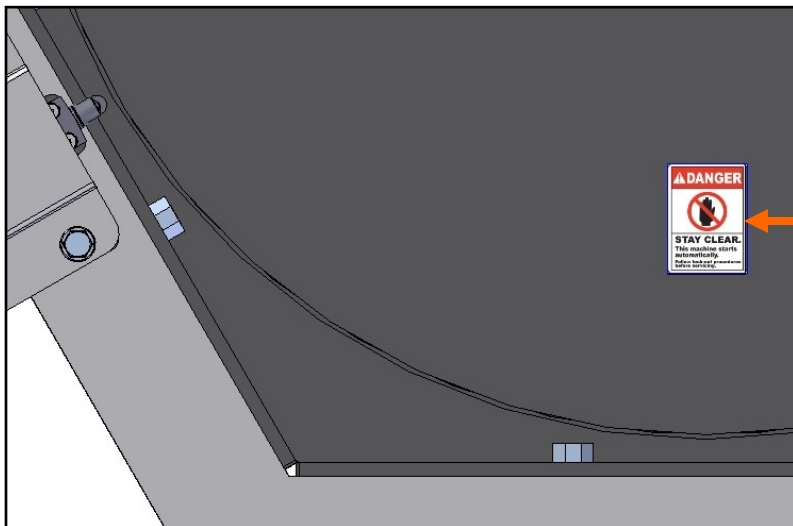

Part # 09-02-0022

**C2D2 SPECIFICATIONS AND LABELS (05-07-0763 VERSION 3 ONLY)**

If any of the panels are located in the hazardous area described in the installation section (see page 19), the following criteria must be met.

1. All 120VAC connections must be hard wired to a listed IP65 rated enclosure in accordance with local electrical codes.
2. The C2D2 certifications are only valid for equipment operating at 60 HZ.
3. The approved operating temperature for this equipment is between 0°C (32°F) and 40°C (104°F).
4. All RJ45 and USB pass-through connector caps must remain closed to achieve a C2D2 rating. Hard wire these connections in accordance with local electrical codes.

The following labels and certification plates must be mounted to the outside of the control panel so that they are in plain view.

MFG. By:  USC  
Max Voltage: 120V, 1PH, 60Hz  
Total FLA: 14  
Largest Motor: 7.2 Amps  
Equipment Model: 05-07-0763  
Suitable to be used in Class II, Div 2, Group G, T4A Hazardous Locations

**!!WARNING!!**  
DISCONNECT POWER BEFORE REMOVING COVERS. KEEP COVERS/  
CONNECTIONS CLOSED WHILE CIRCUITS ARE LIVE. SEE INSTRUCTION MANUAL  
**!!AVERTISSEMENT!!**  
DÉBRANCHER L'ALIMENTATION AVANT DE RETIRER LES COUVERCLES. GARDEZ  
LES COUVERCLES / CONNEXIONS FERMÉS PENDANT QUE LES CIRCUITS SONT EN  
CIRCUIT. VOIR LE MANUEL D'INSTRUCTIONS

**!!WARNING!!**  
EXPLOSION HAZARD. DO NOT REMOVE OR REPLACE CONNECT OR DISCONNECT  
WHILE CIRCUIT IS LIVE UNLESS THE AREA IS FREE OF IGNITIBLE  
CONCENTRATIONS.  
**!!AVERTISSEMENT!!**  
RISQUE D'EXPLOSION. NE PAS ENLEVER OU REMPLACER LA CONNEXION OU LA  
DÉCONNEXION TANT QUE LE CIRCUIT EST EN CIRCUIT SAUF SI LA ZONE EST  
EXEMPTÉ DE CONCENTRATIONS IGNITIABLES.



Certified to  
CSA Std C22.2  
No. 213 & 68

**Intertek**  
4010806  
INDUSTRIAL CONTROL PANEL

Seed Treating Systems For Use In  
Class II Div 2 Group G,  
T4A Location



**Intertek**  
4010806  
INDUSTRIAL CONTROL PANEL



**INSTALLATION****SECTION  
B**

**HIGH VOLTAGE** ~ Always disconnect the power source before working on or near the control panel or lead wires.



HAUTE TENSION ~ Toujours débrancher la source d'alimentation avant de travailler sur ou près du panneau de commande ou les câbles.



**HIGH VOLTAGE** ~ Use insulated tools when making adjustments while the controls are under power.



HAUTE TENSION ~ Utilisez des outils isolés lors des réglages, tandis que les commandes sont sous tension.



Permanent installation may require additional electrical cords, chemical tubing, and air lines, since each installation is unique.



Installation permanente peut exiger cordons électriques, des tubes supplémentaires chimique, et les conduites d'air, puisque chaque installation est.

USC equipment may operate within a Group II, Division 2, Class G hazardous area which contains seed dust. If so, the equipment must be certified for use in this area. To avoid the possibility of an explosion ignited by static electricity, all USC equipment should be grounded by attaching a bonding strip to the metal frame and securing that strip to the factory ground point.

If labeled accordingly, USC products are designed to comply with CSA 22.1 for use in a Class II, Division 2, Group G environment. When connecting the USC system power cord into a power supply, first determine if the supply is also within the hazardous area where the USC system is located. If so, we recommend that the power be hard wired into the source. Do not use a standard electrical plug for this purpose. For other acceptable methods of connecting to a power source, or any other additional miscellaneous equipment to the USC system within a hazardous location, please consult CSA 22.1, Section 18-200 and 18-274. Review the appropriate section and ensure compliance with one of the options given.

When connecting to USC equipment from a remote location, and the USC equipment is in a hazardous Class II, Group G environment, customers are advised to follow the requirements within CSA 22.2 no. 25. More details may also be found in CSA 22.1 18-252 (wiring methods). There are various options covered within this section for wiring in a Class II, Group G (dust) environment. Select the best method suited for your specific location.



équipements USC peut fonctionner dans un Groupe II, Division 2, Classe G zone dangereuse qui contient la poussière des semences. Si oui, l'équipement doit être certifié pour une utilisation dans ce domaine. Pour éviter la possibilité d'une explosion enflammé par l'électricité statique, tous les équipements USC doit être mis à la terre en attachant une bande de liaison à la structure métallique et la sécurisation cette bande au point de masse du fabricant.

Si étiquetés en conséquence, les produits USC sont conçus pour être conformes à la norme CSA 22.1 pour une utilisation dans une Classe II, Division 2, Groupe G environnement. Lors du raccordement du USC alimentation du système cordon dans une alimentation, d'abord déterminer si l'offre Est également dans la zone dangereuse où se trouve le système USC. Si oui, nous recommandons que le pouvoir soit câblé dans la source. Ne pas utiliser une prise électrique standard à cet effet. Pour les autres méthodes acceptables de se connecter à une source d'alimentation, ou tout autre matériel divers supplémentaire au système USC dans un endroit dangereux, se il vous plaît consulter la norme CSA 22.1, Section 18-200 et 18-274. Consultez la section appropriée et assurer la conformité avec lune des options proposes.

Lors de la connexion à l'équipement USC depuis un emplacement distant et l'équipement USC Est dans une classed dangereuse II, Groupe G environnement, les clients sont invites à suivre les exigences dans CSA 22.2 no. 25. Plus de details peuvent également être troves dans 22,1 CSA 18-252 ( Les méthodes de câblage ). Il existe diverse options couvertes dans cette section pour le câblage dans une Classe II, Groupe G (poussière ) environnement. Sélectionnez la meilleure méthode adaptée pour votre emplacement spécifique.

### **TRI-FLO® SET-UP**

The following steps outline the initial set-up of your USC Tri - Flo® System:

1. Confirm all equipment has been received and then contact USC, LLC or your dealer to setup a time for an installation crew to install your Tri - Flo® System.
2. A USC trained install crew will arrive on site and perform the necessary steps for installation of the equipment.

#### **NOTICE**

Based on your particular Tri - Flow® System, some additional equipment may be required for installation (i.e. fork lift(s), crane, etc.

#### **AVIS**

Basé sur votre particulier Tri - Flow System®, certains équipements supplémentaires peuvent être requis pour l'installation (c.-à-chariot élévateur (s), grue, etc.

## TRI-FLO® PANEL CONNECTIONS

### VERSION 4 MAIN CONTROL PANEL



1. Attach the Main Control Panel to the control panel stand using the provided hardware. Determine the permanent location you will be operating the system from, then anchor the stand to the floor. The panel may also be mounted to a wall.
2. There are six MODBUS TCP Ethernet connectors on the Main Control Panel (MCP). If the installation has a version 3 Tri-Flo®, four pump or twelve pump control panels, connect them using one of the Ethernet Ports. These are also used for connecting the Rice Lake 1280 scale head and printers.
3. Connect a cable with four pin connector to one of the three Powerlink connectors on the MCP. Connect the other end to the Powerlink connector on the closest control panel. Repeat this process until all control panels are connected. It may be MCP to Treater to Tri-Flo® to Bin Site panel. The order or number of devices is not important. It is important that all panel are connected. All pump stand control panels will need to be connected in a similar configuration.
4. These connectors will only be used if the Tri-Flo® and Bin Site have Version 3 panels. Connect the gray cable with light blue ends to one of the PJCAN connections on the MCP. Connect the other end to the Version 3 Tri - Flo®, Treater Control panel (if applicable), then on to the Bin Site Control Panel (see page 27).

## VERSION 4 MAIN CONTROL PANEL

5. Connect the red cable to the PJESTOPA on the Main Control Panel (MCP) and then to the PJESTOPB on the next panel that is closest to the MCP. Repeat this process until all control panels are connected in a daisy chain configuration. It may be MCP to Treater to Tri-Flo® to Bin Site panel. The order or number of devices is not important. It is important that each cable is ran from an A connection to a B connection (never A to A or B to B), and that no control panel is left out of the chain. Connect the two red plugs onto each of the remaining open PJESTOP connectors on the first and last panel.
6. There are three USB ports located on the bottom of the panel that may be used to plug in a mouse, keyboard or download reports to a compact flash device.

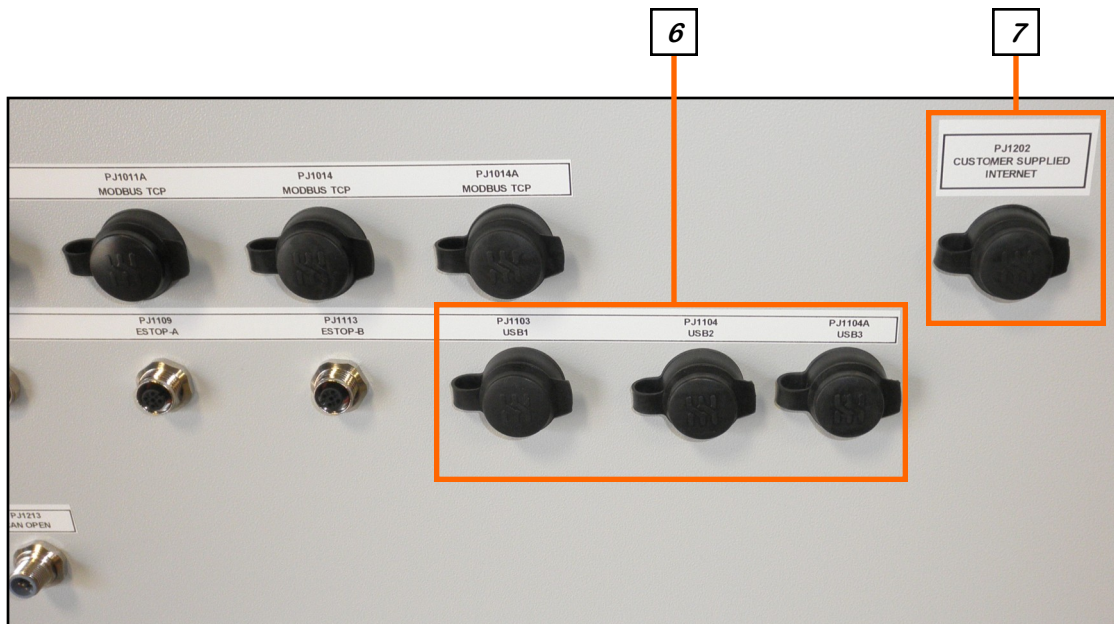

### NOTICE

If using a scale printer, plug the printer communication cable into one of the available MODBUS Ethernet ports located on the bottom of the main control panel. The printer must be located in a safe area.  
**Do not use within a hazardous area which contains seed dust.**

### AVIS

Si vous utilisez une imprimante à échelle, branchez le câble de communication de l'imprimante dans l'un des ports Ethernet MODBUS disponibles situés en bas du panneau de commande principal. L'imprimante doit être située dans une zone sécurisée.  
**Ne pas utiliser dans une zone dangereuse contenant de la poussière.**

**VERSION 4 TRI-FLO® CONTROL PANEL**

7. There is also a connector (PJ1202) where the customer supplied internet connection is made. This is required to use the E-Mail Reports function.
8. Connect one end of the blue communications cable to PJ6114 on the Tri-Flo® control panel to the powerlink connection on the SMC pneumatic distribution assembly (see page 24).
9. Connect the green communications cable from PJ6304 on the Tri-Flo® control panel to the front connection on the servo motor (see page 24).
10. Connect the orange power cable from PJ6005 on the Tri-Flo® control panel to the back connection on the servo motor (see page 24).
11. Connect the black power cable from PJ6012 on the Tri-Flo® control panel to the power connection on the on the SMC pneumatic distribution assembly (see page 24).

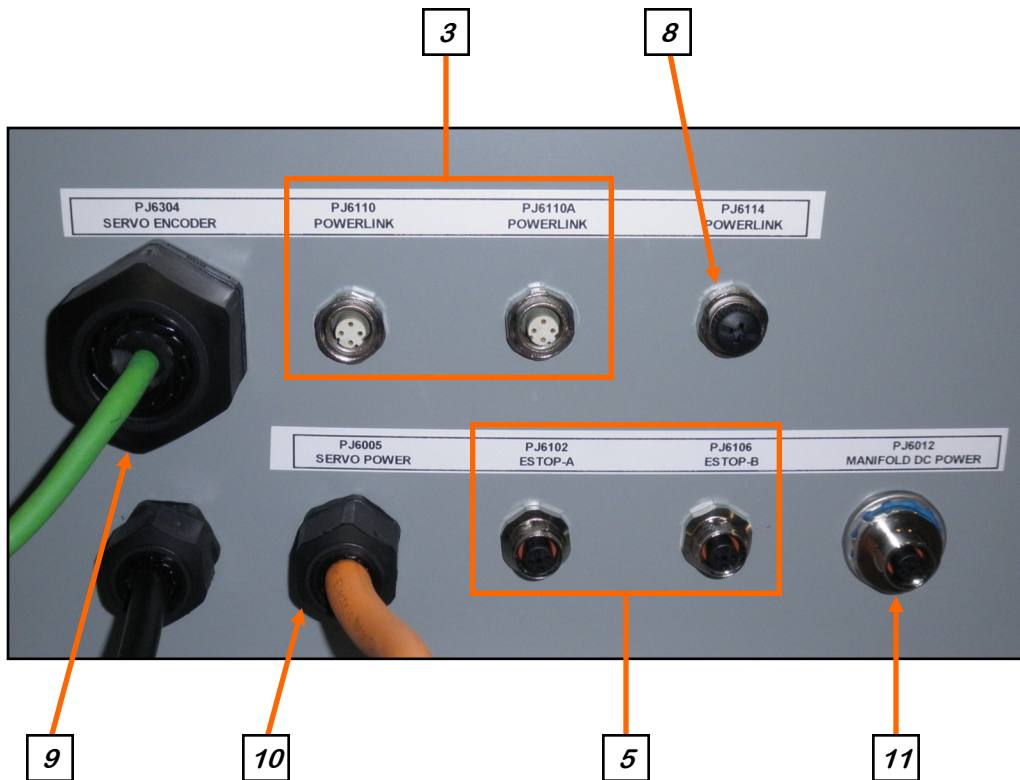



**VERSION 4 SERVO MOTOR**



**VERSION 4 SMC PNEUMATIC CONTROL**

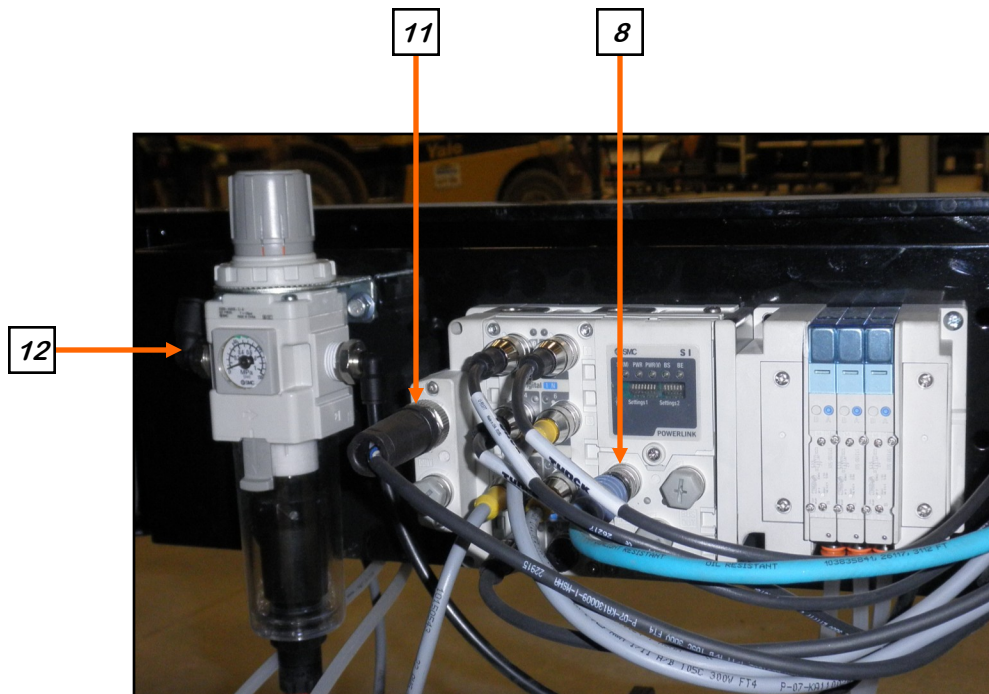



**VERSION 4 BIN SITE CONTROL PANEL**

- 12. Supply approximately 100-110 psi of air pressure at two locations. It is required that this air supply have an in-line customer supplied air dryer to protect the air system from contamination. From the dryer, one line goes to the bottom of the solenoid group on the side of the Bin Site Control Panel. (right) The other line goes from the dryer to the pressure regulator on the Tri - Flo ® System to operate the bin slide gates under the Tri - Flo ® weigh hoppers.
- 13. Have the scales calibrated by a state certified professional scale technician after the USC, LLC trained technician has performed a startup session on your site.



12

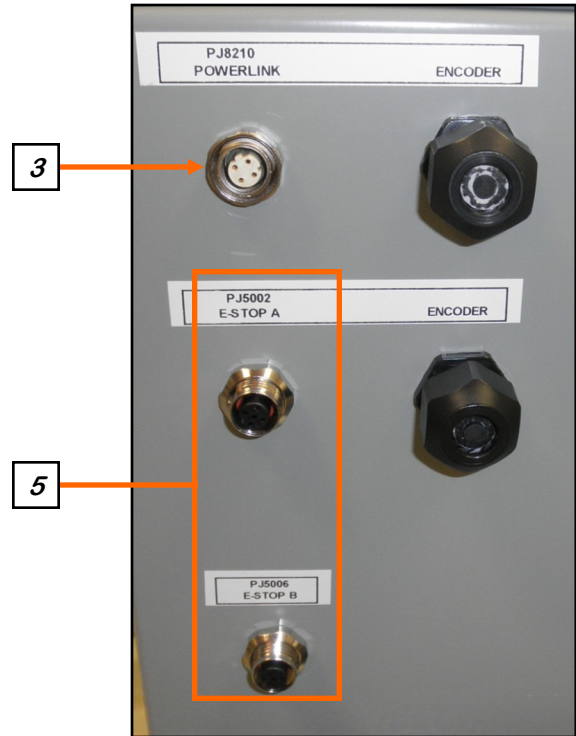

3

5

**VERSION 3 TRI - FLO ® CONTROL PANEL**

14. Connect the 19 pin yellow cable from PJ6012 on the Tri-Flo ® control panel to the shielded junction box located next the distribution spout.
15. Connect two ethernet cables from Tri-Flo ® control panel to the back of the Rice Lake 1280 scale head.
16. Connect the green communications cable from CBL6002 on the Tri-Flo ® control panel to the servo motor.
17. Connect the orange power cable from PJ6506 on the Tri-Flo ® control panel to the servo motor.
18. Connect the black cables from PJHopper 1,2 and 3 to their respective gray junction boxes located on the inside of the horizontal frame cross members.

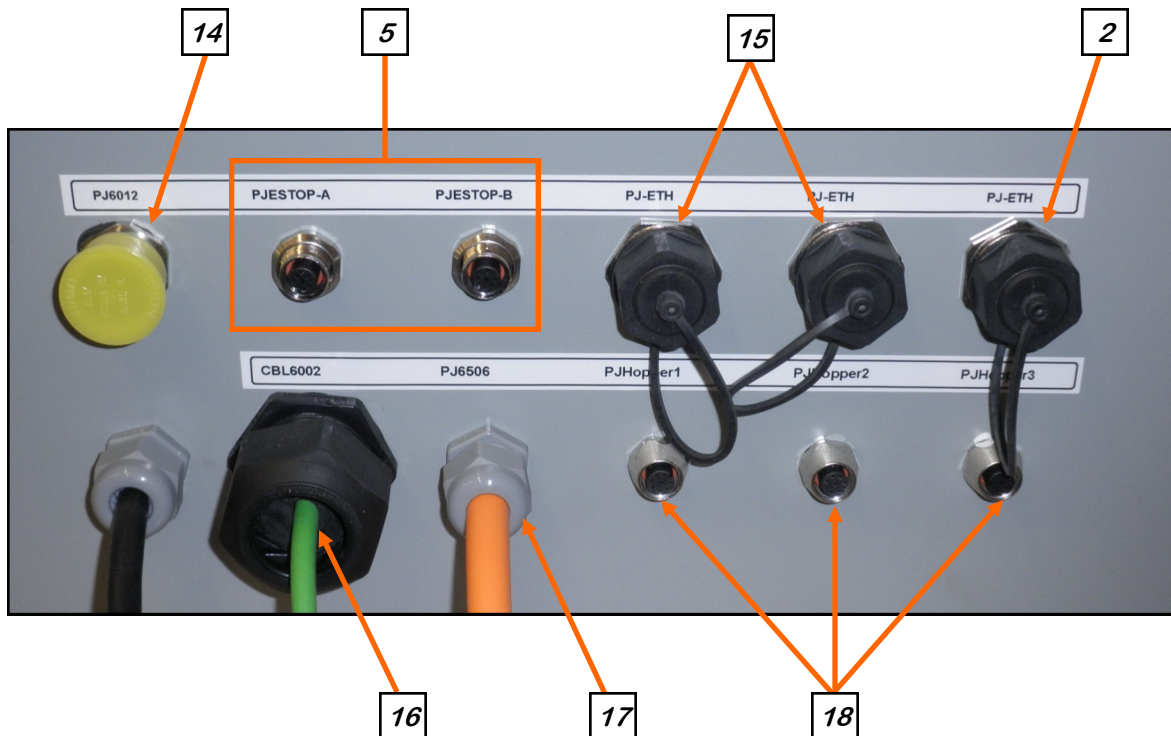

TRI-FLO® SEED WHEEL WITH SERVO  
**VERSION 3 BIN SITE CONTROL PANEL**

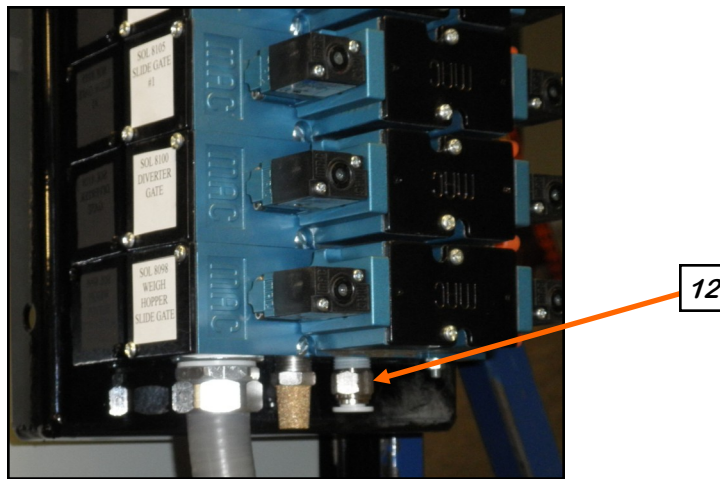
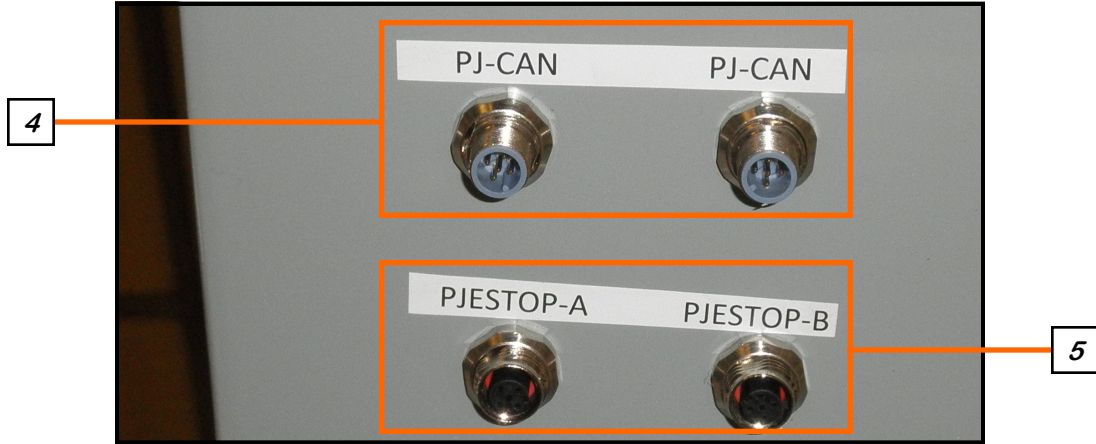

**CONTROL PANEL NAMEPLATES**

19. Have a certified electrician provide power to the seed treating system. Provide convenient shutdown switches, comply with local electrical codes and ensure that the system is properly grounded and bonded. The USC system must be connected to the same electrical requirements as specified in the main control panel on the power requirement tag, or the electrical schematic shipped with the piece of equipment. This will power the USC LPV seed treater and any attached conveyors.

**VERSION 4 MAIN CONTROL PANEL**

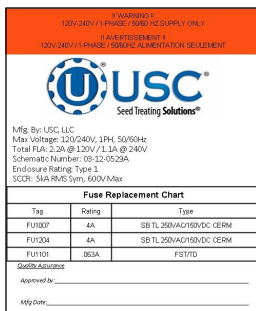

USC Seed Treating Solutions®

Mfg. By: USC, LLC  
 Max Voltage: 120/240V, 1PH, 50/60Hz  
 Total FLA: 2.24 @ 120V / 1.1A @ 240V  
 Schematic Number: 03-12-0529A  
 Enclosure Rating: Type 1  
 SCCR: 5kA RMS Sym, 600V Max

Fuse Replacement Chart		
Tag	Rating	Type
FU607	4A	SB TL 50VAC/15VDC CERM
FU604	4A	SB TL 50VAC/15VDC CERM
FU101	60A	FRTD

Quality Assurance  
 Approved by: \_\_\_\_\_  
 My Date: \_\_\_\_\_

**VERSION 4 TRI-FLO® CONTROL PANEL**

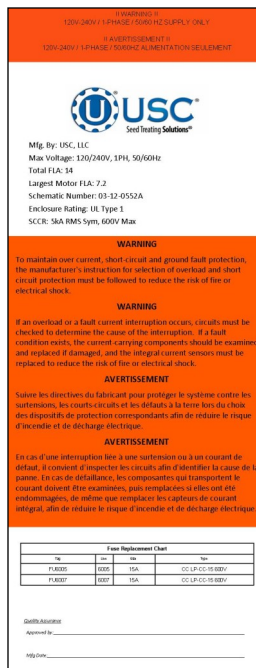

USC Seed Treating Solutions®

Mfg. By: USC, LLC  
 Max Voltage: 120/240V, 1PH, 50/60Hz  
 Total FLA: 34  
 Largest Motor FLA: 7.2  
 Schematic Number: 03-12-0552A  
 Enclosure Rating: UL Type 1  
 SCCR: 5kA RMS Sym, 600V Max

**WARNING**  
 To maintain over current, short circuit and ground fault protection, the manufacturer's instruction for selection of overload and short circuit protection must be followed to reduce the risk of fire or electrical shock.

**WARNING**  
 If an overload or a fault current interruption occurs, circuits must be checked to determine the cause of the interruption. If a fault condition exists, the current carrying components should be examined and replaced if damaged, and the integral current sensors must be replaced to reduce the risk of fire or electrical shock.

**AVERTISSEMENT**  
 Suivre les directives du fabricant pour protéger le système contre les surintensités, les courts-circuits et les défauts à la terre lors du choix des dispositifs de protection correspondants afin de réduire le risque d'incendie et de décharge électrique.

**AVERTISSEMENT**  
 En cas d'une interruption liée à une surintensité ou à un courant de défaut, il convient d'inspecter les circuits afin d'identifier la cause de la panne. En cas de défaillance, les composants qui transportent le courant doivent être examinés, puis remplacés si elles ont été endommagées, de même que remplacer les capteurs de courant intégral, afin de réduire le risque d'incendie et de décharge électrique.

Fuse Replacement Chart			
Tag	Line	Rating	Type
FU605	005	15A	CC LP-CC-15 600V
FU607	007	15A	CC LP-CC-15 600V

Quality Assurance  
 Approved by: \_\_\_\_\_  
 My Date: \_\_\_\_\_

**VERSION 3 TRI-FLO® CONTROL PANEL**

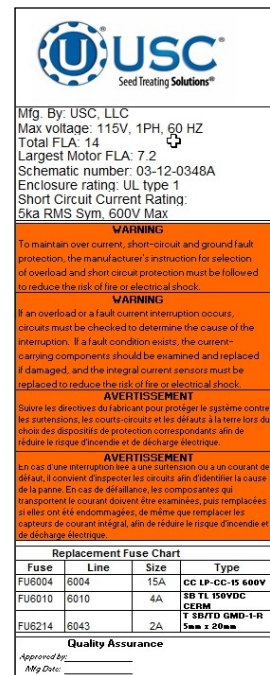

USC Seed Treating Solutions®

Mfg. By: USC, LLC  
 Max voltage: 115V, 1PH, 60 HZ  
 Total FLA: 14  
 Largest Motor FLA: 7.2  
 Schematic number: 03-12-0348A  
 Enclosure rating: UL type 1  
 Short Circuit Current Rating: 5kA RMS Sym, 600V Max

**WARNING**  
 To maintain over current, short-circuit and ground fault protection, the manufacturer's instruction for selection of overload and short circuit protection must be followed to reduce the risk of fire or electrical shock.

**WARNING**  
 If an overload or a fault current interruption occurs, circuits must be checked to determine the cause of the interruption. If a fault condition exists, the current-carrying components should be examined and replaced if damaged, and the integral current sensors must be replaced to reduce the risk of fire or electrical shock.

**AVERTISSEMENT**  
 Suivre les directives du fabricant pour protéger le système contre les surintensités, les courts-circuits et les défauts à la terre lors du choix des dispositifs de protection correspondants afin de réduire le risque d'incendie et de décharge électrique.

**AVERTISSEMENT**  
 En cas d'une interruption liée à une surintensité ou à un courant de défaut, il convient d'inspecter les circuits afin d'identifier la cause de la panne. En cas de défaillance, les composants qui transportent le courant doivent être examinés, puis remplacés si elles ont été endommagées, de même que remplacer les capteurs de courant intégral, afin de réduire le risque d'incendie et de décharge électrique.

Replacement Fuse Chart		
Fuse	Line	Type
FU604	6004	15A, CC LP-CC-15 600V
FU6010	6010	4A, SB TL 50VDC CERM
FU6214	6043	2A, T 50VDC CERM-T-R 1/2in x 20mm

Quality Assurance  
 Approved by: \_\_\_\_\_  
 My Date: \_\_\_\_\_

**NOTICE**

Flexible conduit is recommended for main power supply.

**AVIS**

Conduit flexible Est recommandé pour l'alimentation principale.

20. Provide 110V single phase power to the main control panel, I/O control panel and the pump stand(s). If any of the panels are located in the hazardous area described in the installation section (see page 19), all 110VAC connections must be hard wired to a listed type 4 rated enclosure.

21. Reverse the previous steps when removing the machine from its working position.



*TRI-FLO® SEED WHEEL WITH SERVO*

**NOTES:**



SECTION  
C

**MECHANICAL OPERATION**

**TRI - FLO® OVERVIEW**

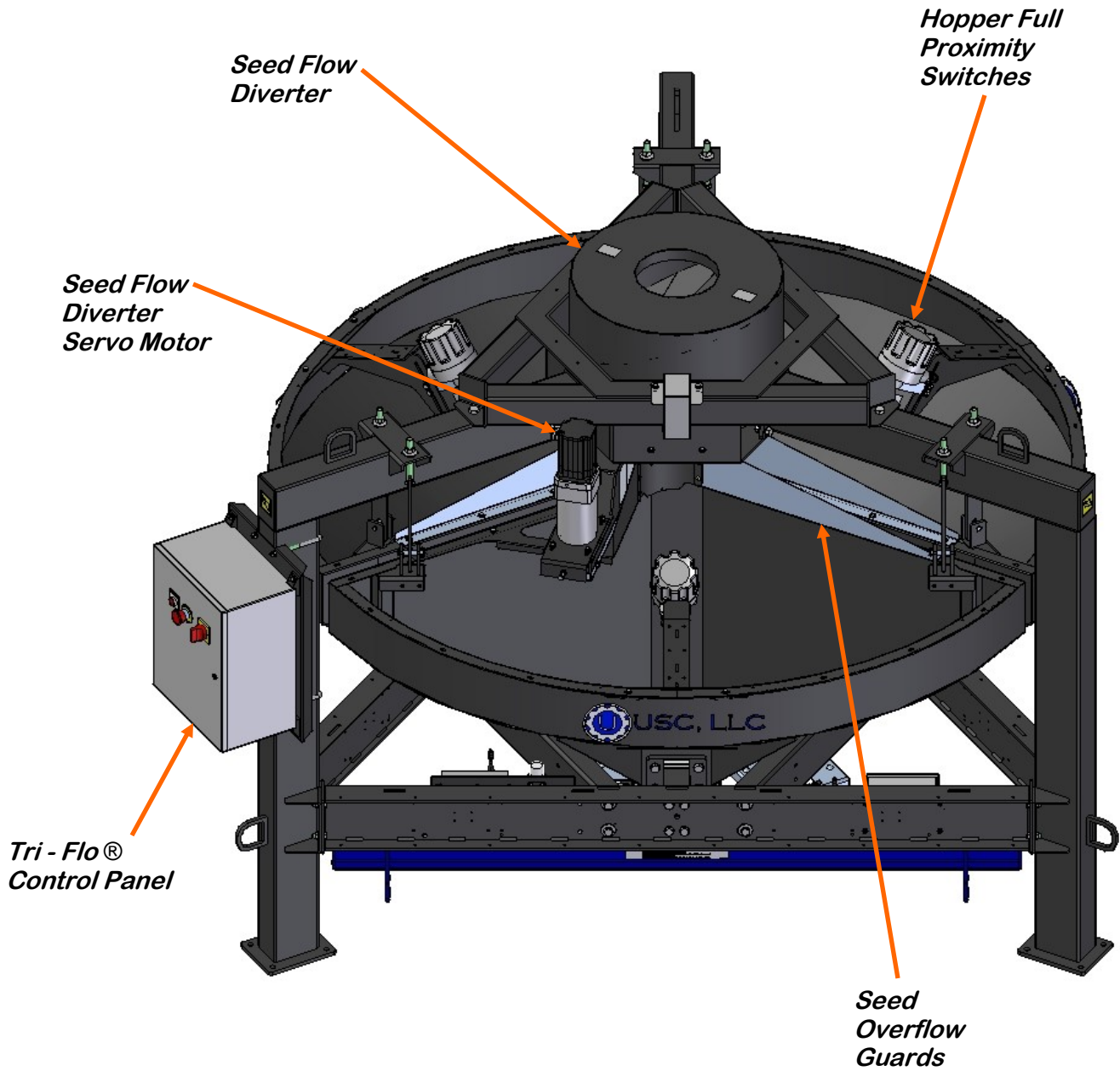



**TRI - FLO ® OVERVIEW**

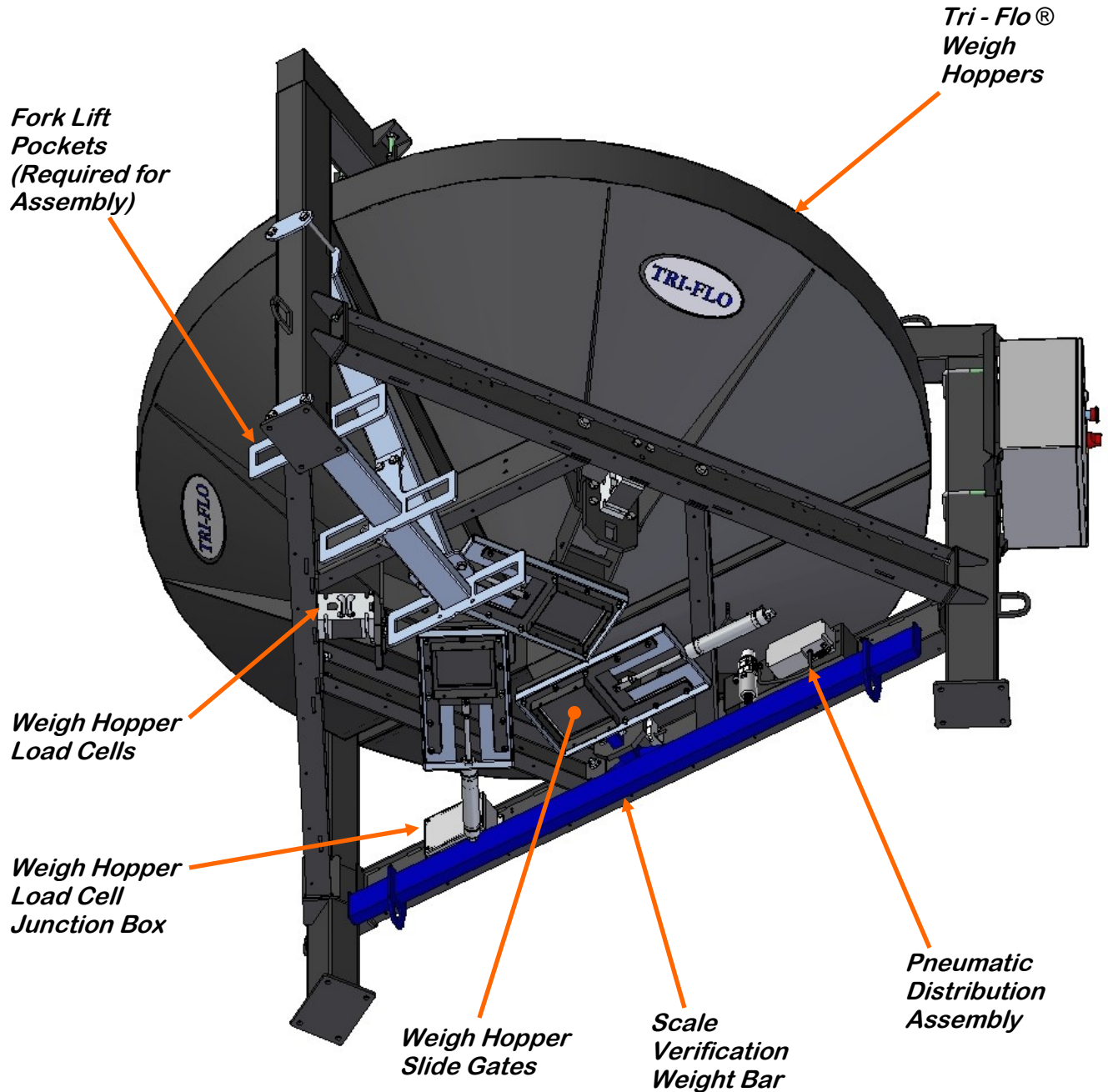

**BIN SITE SYSTEM OVERVIEW**

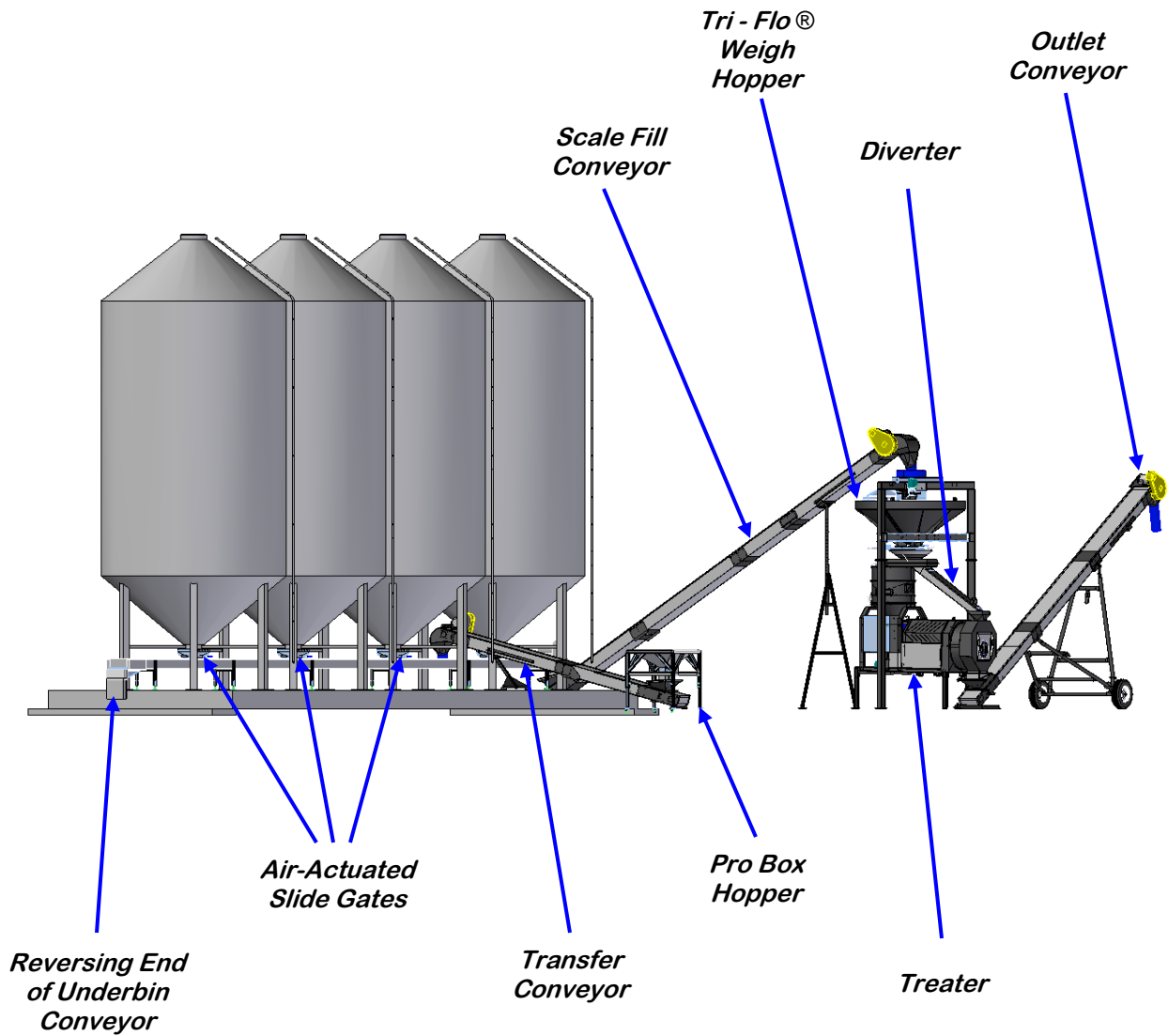

**BIN SITE SYSTEM OVERVIEW**

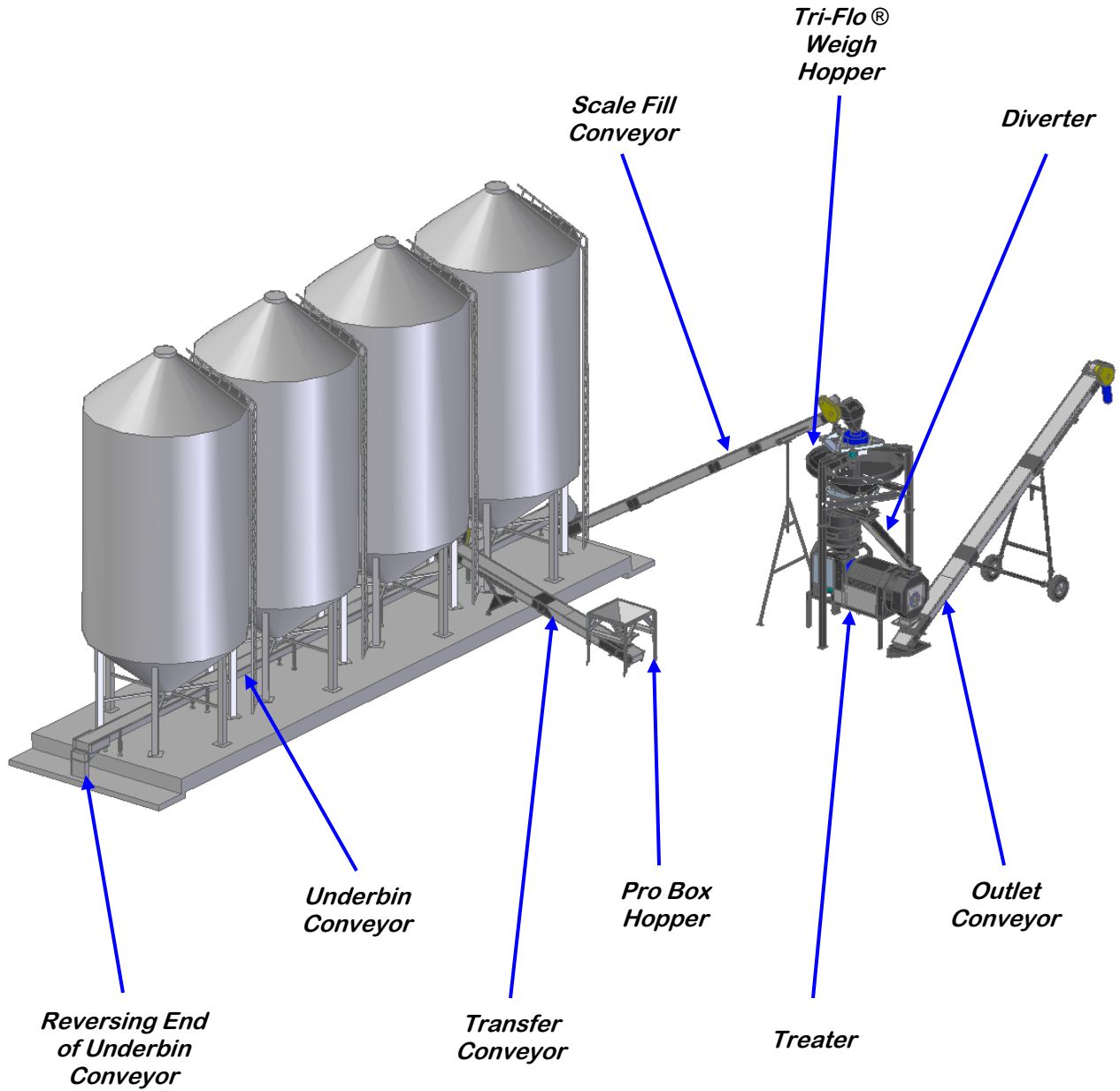

### **BIN SLIDE GATES**

An air-actuated slide gate attaches to the bottom of each bin. The slide gate sits below the manual crank gate on the bin. The flow rate of seed passing through the gate is adjusted by moving the collar on the rod that exits out of the back of the bin slide gate. Moving the collar further away from the bin slide gate will allow the gate to open more and increase seed flow. It is recommended that the manual gate be opened all the way. The system calibrates seed flow through a timing mechanism that tells the air gate to close after a given amount of seed has passed through the gate. During each run of seed, the system will constantly perform an automatic calibration that is flow rate specific. If the manual gate or the collar is adjusted, recalibration of the seed flow will need to be done.

---

### **UNDERBIN CONVEYOR**

The underbin conveyor sits directly below each of the air-actuated slide gates that are in turn positioned directly under the manual slide gates of the bulk bins. The conveyor transports seed forward to the scale fill conveyor. The underbin conveyor may also include an option so that it can run in reverse for clean out purposes. Seed is moved inside the underbin conveyor via a crescent belt. An adjustment for the tracking of this belt is located at both the head and tail section of the conveyor. The head section also includes a viewing window and the tail section has a removable cover to help with proper adjustment. An encoder is located in the tail section of the underbin conveyor. The encoder is used to verify that the conveyor is running without any slippage at the belt.

---

### **UNDERBIN CONVEYOR ENCODER (Optional)**

The underbin conveyor encoder is an electronic device that is connected to a non-drive shaft on the underbin conveyor. This is usually the rear conveyor shaft. The encoder sends an electrical signal to the Tri - Flo ® System whenever the shaft is spinning. That signal allows the Tri - Flo ® System to know that the belt on the underbin conveyor is traveling at the correct speed and that no slippage is occurring. This process allows the Tri - Flo ® System to perform correct auto-calibrations during each run of seed.

---

### **PRO BOX HOPPER (optional)**

The pro box hopper is an inverted pyramid shaped hopper that is used as a means of running seed straight from a pro box into the Tri - Flo ® System. This hopper includes an adjustable slide gate for metering the flow of seed and adjustable legs for changing the height of the hopper.

---

### **TRANSFER CONVEYOR (optional)**

The transfer conveyor is the conveyor that connects the pro box hopper to the rest of the system. This conveyor is located so that its intake hopper is directly under the pro box hopper and its discharge end is feeding into the underbin or scale fill conveyor. This conveyor can be run in the AUTO mode or be run manually via the Tri - Flo ® H-O-A screen.

## **SCALE FILL CONVEYOR**

The scale fill conveyor is a fixed conveyor that is used to transport seed from the discharge end of the underbin conveyor to the top of the weigh hopper. This conveyor's intake hopper will sit directly under the discharge portion of the underbin conveyor and the discharge end of the scale fill conveyor will be directly above the center of the Tri-Flo ®. The scale fill conveyor is commonly used as the device that brings seed from outside of the treater building to the inside.

---

## **TRI - FLO ® WEIGH HOPPER, SLIDE GATES & SCALE HEAD**

Once seed exits the discharge end of the scale fill conveyor, it will fall down into an inlet diverter that is located in the center of the Tri - Flo ®. Seed will then come to rest above the slide gate in one of the three weigh hoppers as it waits to be weighed. The weigh hoppers sit atop load cells. The system uses a Rice Lake 1280 scale head to display the current weight of the seed in the weigh hoppers. The scale head communicates with the system via an Ethernet cable. Once the first hopper has been filled, seed will be diverted to the second hopper. While the second hopper is filling the first hopper will then weigh the seed and begin dumping out of its discharge gate. This process runs in a continuous flow until the system determines the total weight has left the bin. At this point the bin slide gate is closed and the program runs in the finish batch mode. Once the run is finished the system begins to shutdown the conveyers in the order specified by the time entered on the Utilities screen to assure that all seed has been cleaned out of the conveyers. The system looks to the scale head for the total weight of seed and prints a scale ticket based on that weight.

### **NOTICE**

The Rice Lake 1280 scale head will require calibration by a state certified calibration specialist in order for it to be legal for trade.

### **AVIS**

Le Rice Lake 1280 la tête de l'échelle, il faudra calibration par un spécialiste de l'étalonnage diplômé d'état pour qu'il soit légal pour le commerce.

Located below each weigh hopper is an air-actuated slide gate. The slide gates each have a sensor that is positioned to read whether or not the slide gate is currently in the open or close position. This is done to ensure an accurate scale reading will always be achieved.

---

## **DIVERTER (optional)**

The diverter is an air actuated gate that is located above the seed wheel and below the Tri - Flo ®. The diverter gate will sit in one of two positions: Treat or Bypass. When the gate is in the treat position, seed will flow into the treater to have chemical applied to it. When the gate is in the bypass position, seed will not enter the treater but instead will be carried away through a separate chute to a conveyor or holding device. The diverter can be manually actuated by pressing and holding the Treat or Bypass button in the lower right corner of the Tri-Flo ® H-O-A screen.

SECTION  
D

## ELECTRICAL OPERATION



**HIGH VOLTAGE** ~ Always disconnect the power source before working on or near the control panel or lead wires.



HAUTE TENSION ~ Toujours débrancher la source d'alimentation avant de travailler sur ou près du panneau de commande ou les câbles.



**HIGH VOLTAGE** ~ Use insulated tools when making adjustments while the controls are under power.



HAUTE TENSION ~ Utilisez des outils isolés lors des réglages, tandis que les commandes sont sous tension.



**AUTHORIZED PERSONNEL** only shall work on the control panel. Never allow anyone who has not read and familiarized themselves with the owner's manual to open or work on the control panels.



Seules personnes autorisées doivent travailler sur le panneau de commande. Ne jamais laisser quelqu'un qui n'a pas lu et se sont familiarisés avec le manuel d'ouvrir ou de travail du propriétaire

For the TRI - FLO ® Bin Site HMI instructions, see the appropriate U-Treat Automation manual.

This section provides a general overview and description of the operator controls for the Tri-Flo ® System.



**USC recommends the use of a surge protection device with a minimum rating of 400 Joules for all automated main control panels.**



**USC recommande l'utilisation d'un dispositif de protection contre les surtensions avec une cote minimale de 400 joules pour tous les principaux panneaux de contrôle automatisés.**



**General Panel Descriptions:**

This system consists of three panels:

- The Tri - Flo ® Control Panel (TFCP) is a plug connected enclosure that is located on the Tri - Flo ®. This enclosure contains the PLC components required for the Tri - Flo ® weighing system.
- The Automated Main Control Panel is a plug connected enclosure that contains the PLC (Programmable Logic Controller) as well as the HMI (Human Machine Interface) touch screen. The operator is able to control the entire system through the HMI. Power to this panel is supplied by a standard 110V plug.

**SECTION  
E**

**TROUBLESHOOTING**

**TROUBLESHOOTING**

Below is a table describing the most frequent problems and solutions with the USC Tri - Flo ® bin site system. For further assistance, contact USC at (785) 431-7900.

Problem	Possible cause	Solution
Tri - Flo ® : Minimum flow rate alarm.	1. Running too low capacity.	1. Adjust your air gates or manual gates.
Tri - Flo ® : Indicator weight shows two pounds in bin after run.	1. Tri - Flo ® did not empty completely.	1. Open gates on the Tri - Flo ® and zero scales.
Tri - Flo ® : Scale will not zero out.	1. Scale is in filing mode. 2. Scale is to far out of range.	1. Exit filling mode then end run. Needs to be in shipping mode. 2. Recalibrate scale
Tri - Flo ® : Even when all three scales are zeroed on Batch, the next batch gives a negative number on one of the hoppers with an overweight Alarm.	1. Tri - Flo ® was not emptied before zeroed. 2. Wind drafts. 3. Hoppers are touching.	1. Open gates and zero scale. 2. Close doors. 3. Loosen the four mounting bolts enough to be able to move the hopper. Make the gap on both sides of the hopper as even as possible.
Tri - Flo ® : If there are five pounds or less in the hopper, the system will not empty hopper.	1. Scale heel weight has not been reached.	1. Open and close the gate hopper.
System is not consistently calibrating correctly.	1. Bin slides gates or manual gates have been moved. 2. Underbin conveyor belt is slipping. 3. Bin slide gate is not consistently opening to the same point. 4. The operator is pressing the "Cancel Scale Fill" button before the run ends. 5. System is being paused during the run.	1. Ensure that the slide gate collar and manual gate is locked into place. Then recalibrate. 2. Tighten the underbin conveyor belt. 3. Check for any obstruction that may be restricting the movement of the slide gate. 4. Allow the system to shutdown on its own. 5. Make another run without pausing system.

TRI - FLO ® SEED WHEEL WITH SERVO

Problem	Possible Cause	Solution
System calibration for currently selected bin is incorrect.	1. System is too far out of calibration to recalibrate automatically.	1. Recalibrate the system.
Weight display not reading steady (Bouncing)	1. Wind drafts. 2. Bad load cell.	1. Close doors. 2. Replace load cell.
Scale is reading incorrect weight.	1. Something is touching the scale. 2. Scale needs recalibrated.	1. Ensure that the area around the scale is clean and that nothing is leaning on or resting on the hopper. 2. Zero scale. If still incorrect, have a professional scale technician recalibrate the scale.
No Tri - Flo ® slide gates will open or close when their corresponding button is pressed on the touch screen.	1. No air or not enough air is being supplied to the air regulator / filter on the frame cross member. 2. The Tri - Flo ® PLC may be off.	1. Ensure that at least 100 psi of air is being supplied to the regulator and it is adjusted for a minimum output of 45 PSI. Also, check to see that the filter is clean and no water has built up above the maximum allowed line. 2. Ensure that the Tri - Flo ® control panel has power to it, is ON and that all of the breakers inside the panel are ON as well.
No bin slide gates will open or close when their corresponding button is pressed on the touch screen.	1. No air or not enough air is being supplied to the solenoid bank on the side of the bin site control panel. 2. The bin site PLC may be off.	1. Ensure that at least 100 psi of air is being supplied to the solenoid bank. 2. Ensure that the bin site control panel has power to it, is ON and that all of the breakers inside the panel are ON as well.
Air gate will not close fully.	1. Something is obstructing the air gate from closing. 2. Air pressure to the gate is not strong enough.	1. Remove obstruction. 2. Ensure that the bin slide gate has at least 100 psi of air being supplied to it. If it is a Tri - Flo ® slide gate it needs at least 45 PSI.
Air gate is opening when it should be closing and vice versa.	1. Air lines to the air gate are reversed.	1. Exchange air line for the proper solenoid on the back of the solenoid bank.

Problem	Possible Cause	Solution
Diverter is leaking seed through bypass side while in TREAT mode of operation.	<ol style="list-style-type: none"> <li>1. Too low of air pressure to actuate the diverter.</li> <li>2. An obstruction in the diverter is stopping correct placement of the diverter plate.</li> </ol>	<ol style="list-style-type: none"> <li>1. Ensure that at least 100 psi of air pressure is present at the diverter.</li> <li>2. Remove obstruction.</li> </ol>
Solenoids are making a buzzing sound when air gates are actuated.	<ol style="list-style-type: none"> <li>1. Moisture in the air system.</li> <li>2. Electric actuator on solenoid bank may be faulty.</li> </ol>	<ol style="list-style-type: none"> <li>1. Remove moisture from the air lines.</li> <li>2. Replace the electronic actuator on the solenoid.</li> </ol>
The touch screen has warning triangles on each button.	<ol style="list-style-type: none"> <li>1. The bin site PLC may be off.</li> <li>2. The Tri - Flo ® panel may be off.</li> </ol>	<ol style="list-style-type: none"> <li>1. Ensure that the bin site control panel has power to it, is ON and that all of the breakers inside the panel are ON as well.</li> <li>2. Ensure that the Tri - Flo ® control panel has power to it, is ON and that all of the breakers inside the panel are ON as well.</li> </ol>
Conveyor will not start in HAND or AUTO mode.	<ol style="list-style-type: none"> <li>1. Conveyor motor starter is tripped.</li> <li>2. Conveyor is clogged.</li> </ol>	<ol style="list-style-type: none"> <li>1. Reset motor starter.</li> <li>2. Remove obstruction or debris.</li> </ol>

## UNPLUGGING CONVEYORS

In unusual moisture or material conditions, the machine can plug. When unplugging, follow this procedure:

1. Place all controls in neutral or off, stop motor, disable and lock out power source before unplugging.
2. Remove the nut, bolt and sliding clean out door from the bottom of the inlet tube section of the conveyor. Remove any built up material. Reinstall door and hardware.
3. Open the tail cover (below).
4. Remove plugged material.
5. Install and secure conveyor and tail covers.



*Sliding Clean Out Door*

*Remove shipping bolts  
after receiving  
conveyor*

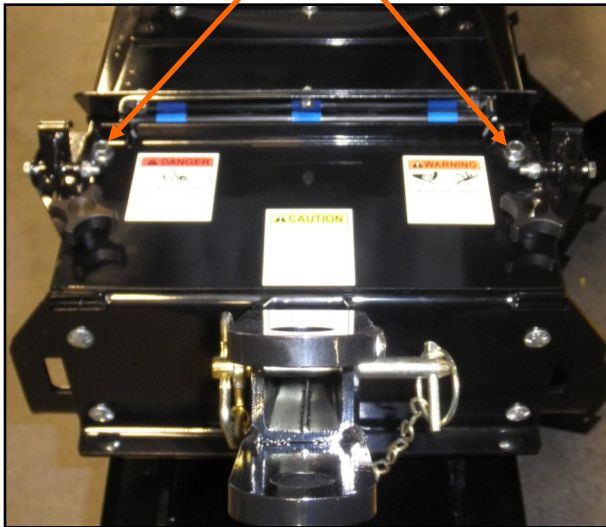

*Bottom clean-out cover*

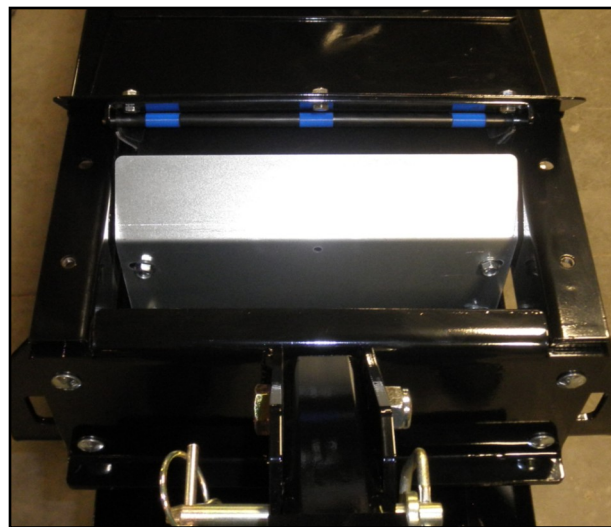

*Bottom clean-out cover removed*



SECTION  
F**MAINTENANCE**

Proper maintenance of the Tri-Flo ® System is critical for peak performance, reliability and accuracy of this system. The following is a guideline for the type of maintenance and servicing that should be performed on this unit. Your environment and uses may require additional maintenance and service beyond this list to assure a reliable and safe unit. The operator of this unit has ultimate responsibility to identify areas of concern and rectify them before they become a hazard or safety issue. There is no substitute for a trained, alert operator.



Do not put this unit into operation with any questionably maintained parts. Poor performance or a hazard may occur.



Ne pas mettre cet appareil en service avec des pièces douteuse entretenus. La mauvaise performance ou un danger peut survenir.



Do not use compressed air or water under pressure to clean any of the components of the USC equipment.



Ne pas utiliser d'air comprimé ou de l'eau sous pression pour nettoyer l'un des composants de l'équipement USC.

**GREASING**

Use an SAE multipurpose high temperature grease with extreme pressure (EP) performance. Also acceptable is an SAE multipurpose lithium-based grease.

- Use a Maintenance Checklist to keep record of all scheduled maintenance.
- Use a hand-held grease gun for all greasing.
- Wipe grease fitting with a clean cloth before greasing to avoid injecting dirt and grit.
- Replace and repair broken fittings immediately.

**Storing Lubricants**

Your machine can operate at top efficiency only if clean lubricants are used. Use clean containers to handle all lubricants. Store them in an area protected from dust, moisture and other contaminants.



If fittings will not take grease, remove and clean thoroughly. Also clean lubricant passageway. Replace fitting if necessary.



Si les raccords ne prendront pas la graisse, enlever et nettoyer. Aussi propre passage de lubrifiant. Remplacer approprié si nécessaire .

### **TRI-FLO® WEIGH HOPPER, AIR REGULATOR - FILTER - DRYER**

- **DEPRESSURIZE UNIT BEFORE REMOVING BOWL.**
  - Periodically check bowl unit for cracking, damage or other deterioration. Immediately replace any bowl unit that is cracked, damaged or deteriorated.
  - Remove micron filter and clean by tapping on surface and blowing off with compressed air.
  - Exercise and flush the automatic drain valve.
- 

### **CONTROL PANEL & AIR SYSTEM**

- Drain water from compressor daily.
  - Drain air dryer every 40 hours of operation.
  - Test all air solenoids for correct actuation.
  - Inspect all exterior wiring for any kinks or damage.
- 

### **DIVERTER (optional)**

- Inspect all welds and structural components for bends, cracks, and damage.
  - Test diverter gate for proper actuation with control panel.
  - Clean diverter tubing of any obstructions.
  - Grease all necessary bearings.
- 

### **BIN SLIDE GATES**

- Inspect all welds and structural components for bends, cracks and damage.
  - Test slide gates for proper actuation with control panel.
  - Remove air to gates and manually open and close gates. Check for any friction while gate is sliding.
- 

### **UNDERBIN CONVEYOR**

- Inspect all welds and structural components for bends, cracks and damage.
- Clean out any build up of debris from the clean out door.
- Check the conveyor belt tension and alignment (page 48).
- Check the drive belt tension and alignment (page 51).
- Grease all necessary bearings (page 42).
- Remove black guard and check chain tension.
- Check for proper operation of conveyor while in reverse mode. Align if necessary.
- Check encoder for tightness to shaft and proper signal to control panel.

### **PRO BOX HOPPER & TRANSFER CONVEYOR (optional)**

- Inspect all welds and structural components for bends, cracks, and damage.
- Clean out any build up of debris from the clean out door.
- Check the conveyor belt tension and alignment (page 48).
- Check the drive belt tension and alignment (page 51).
- Grease all necessary bearings (page 42).
- Remove black guard and check chain tension.
- Wipe down the motor casing with a damp cloth making sure to remove all dust that may have collected since the last maintenance date. Record the cleaning on the company required documents. If operating in a CSA 22.1, Class II, Division 2, Group G hazardous area, USC recommends this step be performed on a daily basis.
- Essuyez le carter moteur avec un chiffon humide en veillant à éliminer toutes les poussières qui peuvent avoir perçu depuis la dernière date de maintenance. Enregistrez le nettoyage sur la société les documents requis. Si opérant dans un CSA 22.1, Classe II, Division 2, Groupe G zone dangereuse, USC recommande cette étape être effectuée sur une base quotidienne.

---

### **SCALE FILL CONVEYOR**

- Inspect all welds and structural components for bends, cracks and damage.
- Clean out any build up of debris from the clean out door.
- Check the conveyor belt tension and alignment (page 48).
- Check the drive belt tension and alignment (page 51).
- Grease all necessary bearings (page 42).
- Remove black guard and check chain tension.
- Wipe down the motor casing with a damp cloth making sure to remove all dust that may have collected since the last maintenance date. Record the cleaning on the company required documents. If operating in a CSA 22.1, Class II, Division 2, Group G hazardous area, USC recommends this step be performed on a daily basis.
- Essuyez le carter moteur avec un chiffon humide en veillant à éliminer toutes les poussières qui peuvent avoir perçu depuis la dernière date de maintenance. Enregistrez le nettoyage sur la société les documents requis. Si opérant dans un CSA 22.1, Classe II, Division 2, Groupe G zone dangereuse, USC recommande cette étape être effectuée sur une base quotidienne.

### **TRI-FLO ® WEIGH HOPPER, SLIDE GATE & SCALE HEAD**

- Inspect all welds and structural components for bends, cracks and damage.
  - Check for binding on scale components.
  - Check wiring from scale to scale head for any damage or kinks.
  - Test slide gate for proper actuation with control panel.
  - Check slide gate sensors for correct positioning and signal.
  - Have scale professionally re-calibrated as necessary.
  - Wipe down the motor casing with a damp cloth making sure to remove all dust that may have collected since the last maintenance date. Record the cleaning on the company required documents. If operating in a CSA 22.1, Class II, Division 2, Group G hazardous area, USC recommends this step be performed on a daily basis.
  - Essuyez le carter moteur avec un chiffon humide en veillant à éliminer toutes les poussières qui peuvent avoir perçu depuis la dernière date de maintenance. Enregistrez le nettoyage sur la société les documents requis. Si opérant dans un CSA 22.1, Classe II, Division 2, Groupe G zone dangereuse, USC recommande cette étape être effectuée sur une base quotidienne.
- 

### **TRANSITION CONVEYOR (optional)**

- Inspect all welds and structural components for bends, cracks and damage.
- Clean out any build up of debris from the clean out door.
- Check the conveyor belt tension and alignment (page 48).
- Check the drive belt tension and alignment (page 51).
- Grease all necessary bearings (page 42).
- Remove black guard and check chain tension.
- Wipe down the motor casing with a damp cloth making sure to remove all dust that may have collected since the last maintenance date. Record the cleaning on the company required documents. If operating in a CSA 22.1, Class II, Division 2, Group G hazardous area, USC recommends this step be performed on a daily basis.
- Essuyez le carter moteur avec un chiffon humide en veillant à éliminer toutes les poussières qui peuvent avoir perçu depuis la dernière date de maintenance. Enregistrez le nettoyage sur la société les documents requis. Si opérant dans un CSA 22.1, Classe II, Division 2, Groupe G zone dangereuse, USC recommande cette étape être effectuée sur une base quotidienne.

## **CONVEYOR MAINTENANCE SCHEDULE**

Proper maintenance of the Tube Series Conveyors is critical for peak performance, reliability and accuracy of this system. The following is a guideline for the type of maintenance and servicing that should be performed on this unit. Your environment and uses may require additional maintenance and service beyond this list to assure a reliable and safe unit. The operator of this unit has ultimate responsibility to identify areas of concern and rectify them before they become a hazard or safety issue. There is no substitute for a trained, alert operator.



Do not put this unit into operation with any questionably maintained parts. Poor performance or a hazard may occur.



Ne pas mettre cet appareil en service avec des pièces douteuse entretenus. La mauvaise performance ou un danger peut survenir.



Do not use compressed air or water under pressure to clean any of the components of the USC equipment.



Ne pas utiliser d'air comprimé ou de l'eau sous pression pour nettoyer l'un des composants de l'équipement USC.



Failure to maintain the proper belt tension will cause the belt to slip. This will damage the belt and head drive pulley. If the belt is not tracking correctly, it can ride along one edge causing the belt to fray and damage the belt splice. Either problem will cause the belt to burn or wear out prematurely.



Défaut de maintenir la tension de la courroie provoquera la courroie de glisser. Cela pourrait endommager la courroie et la tête d'entraînement pulley. Si la courroie ne suit pas correctement, il peut rouler le long d'un bord causant la courroie effiloche et endommager l'épissure de ceinture. Soit problème provoquera la ceinture de brûler ou d'usure prématurée.



## CONVEYOR SERVICING INTERVALS

### Every 40 hours or Weekly

1. Check the conveyor belt tension and alignment.
  2. Grease conveyor bearings.
    - A. Two bolt flanged bearings, tail roller bearings right and left (2 locations).
    - B. Two bolt flanged bearings, drive roller bearings right and left (2 locations).
  3. Remove guard and check the drive belt tension and alignment. The belts will deflect approximately 1/4 to 1/2 inch when properly tensioned.
  4. Wipe down the motor casing with a damp cloth making sure to remove all dust that may have collected since the last maintenance date. Record the cleaning on the company required documents. If operating in a CSA 22.1, Class II, Division 2, Group G hazardous area, USC recommends this step be performed on a daily basis.
- Essuyez le carter moteur avec un chiffon humide en veillant à éliminer toutes les poussières qui peuvent avoir perçu depuis la dernière date de maintenance. Enregistrez le nettoyage sur la société les documents requis. Si opérant dans un CSA 22.1, Classe II, Division 2, Groupe G zone dangereuse, USC recommande cette étape être effectuée sur une base quotidienne.

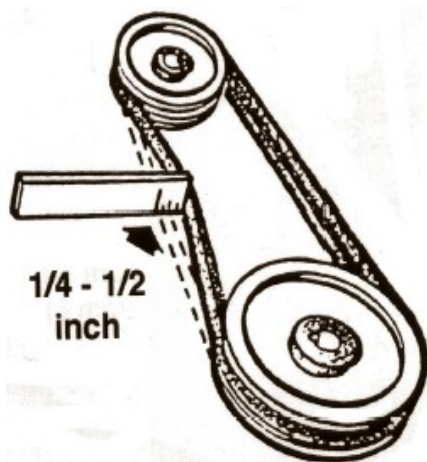

**Every 200 hours or Annually**

1. Repack wheel bearings.
2. Wash machine.
3. Check pulley bushing for wear. To inspect pulley:
  - A. Lower the conveyor to its lowest position.
  - B. When the conveyor has reached the lowest position, it will stop at the pins.
  - C. Unwind the winch two more turns, or until enough slack in the cable is achieved.
  - D. Loosen and remove the bolt.
  - E. Inspect the bushing on the pulley for wear.
  - F. Reverse steps A-D for re-assembly.

---

**CONVEYING BELT TENSION AND ALIGNMENT - TAIL END**

A contoured belt with molded flights is used to convey material along the frame. The tension and alignment of the belt should be checked weekly, or more often if required, to be sure that it does not slip or run to one side. A properly tensioned belt will not slip when it is operating. Operating the belt with less slippage will increase the belt life and causes less stress on bearings, pulleys and shafts.



Although it is acceptable to align the belt from either the Head or the Tail (Intake) end. Tightening the belt may only be done from the Tail end of the conveyor.



Même se il Est acceptable d'aligner la courroie de la tête ou la queue (Intake) fin. Serrer la ceinture ne peut être fait à partir de la fin de queue du convoyeur.

## CONVEYING BELT TENSION AND ALIGNMENT - TAIL END

To maintain the belt, follow this procedure:

### NOTICE

Place all controls in neutral or off, stop motor and disable power source before working on belt.

### AVIS

Placez toutes les commandes au point mort ou hors tension, arrêter le moteur et désactiver la source d'alimentation avant de travailler sur la ceinture.

1. Use the take-up bolt located at the tail to set the tension of the belting.
2. If the belt needs to be tightened to prevent slippage, use the take-up adjustments on the tail end only.
3. The belt is tightened by turning both take-up adjustments an **equal** number of turns.
4. Use the drive roller to check the alignment. The belt should be centered.
5. Turn the belt 1/2 revolution when the belt is new and check the drive and tail roller. If out of alignment, the belt will move to the loose side. Loosen the jam nut and use the bearing position bolts to set the position. Tighten jam nut.
6. Run and check again. Check frequently during the first few minutes of operation and then several times during the first 10 hours. The belt normally seats itself during the first 10 hours of operation and can be checked weekly after that.
7. The belt is properly aligned when the belt runs in the center of the head and tail rollers.

*Loosen these jam nuts before adjusting the bearing position bolt*

*Use this bolt to tighten and align the belt*

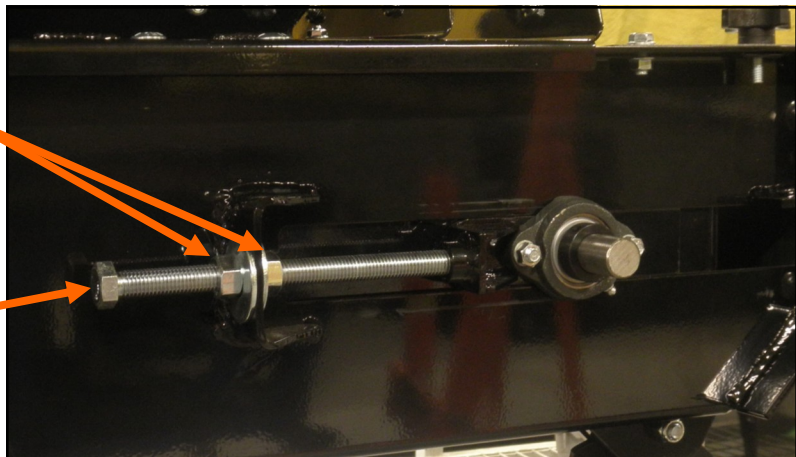

## **CONVEYING BELT ALIGNMENT - HEAD END**

1. A misaligned belt will track toward the loose side. Set the tracking by loosening the bearing mounts on the tight side and using the bearing position bolt to move the end of the head roller toward the tail. Tighten the bearing mount when the belt is centered on the head roller.
2. Run the belt and check the tracking again. Loosen the tight side slightly again if required. Repeat the adjusting and checking procedure until the belt centers on the inlet end roller and remains centered when running.
3. Always repeat this aligning procedure when installing a new belt. Check frequently during the first 10 hours of operation. After 10 hours, the belt is normally seated and checking the alignment can be done less frequently.

*Tighten jam nuts  
after adjustment*

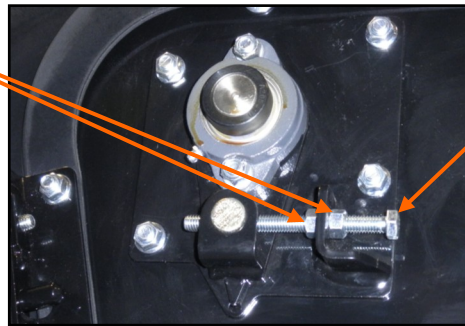

*Use this bolt to  
align the belt*

## **BELT REPLACEMENT**

1. Rotate the belt until the seam is visible.
2. Move the tail roller to its loosest position.
3. Pull all the slack to the seam area.
4. Remove the wire connector and open the belt.
5. Attach one end of the replacement belt to the belt end being removed.
6. Pull the old belt out and the new belt will be threaded into place.
7. Disconnect the old belt.
8. Connect the ends of the new belt together and secure.
9. Set the belt tension.
10. Check and set the belt alignment

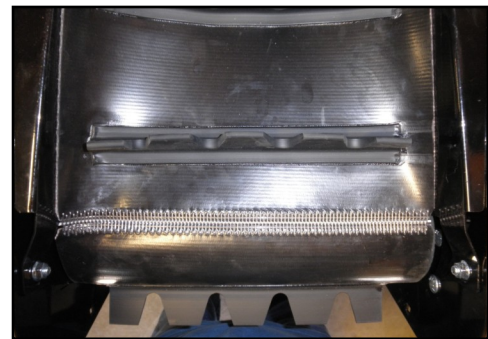

*Belt Seam*

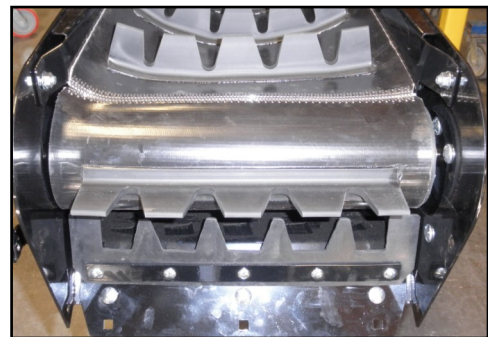

*Check Alignment*



## **DRIVE BELT TENSION & ALIGNMENT**

Power to the conveying belt is transmitted through a V-belt. The V-belt drive system must be maintained at the proper belt tension and pulley alignment to obtain the desired performance and life. When maintaining the belt drive system for the electric drive model, follow this procedure:

### **NOTICE**

Turn motor off and unplug power cord or turn off power and lock out the master panel before starting maintenance on drive belt system.

### **AVIS**

Arrêter le moteur et débranchez le cordon d'alimentation ou coupez l'alimentation et verrouiller le panneau de maître avant de commencer la maintenance sur le système de courroie

### **Drive Belt Tension**

1. Push on the center of the belt span with a force of approximately 5 to 10 lbs.
2. Follow the belt tensioning specification on page 52 to determine proper belt deflection.
3. Move the motor up, using the adjustment bolt, to set drive belt tension (right).
4. Close and secure guards.

### **Drive Belt Alignment**

1. Lay a straightedge across the pulley faces to check the alignment (right).
2. Use the pulley hub or the motor mounting plate slots to move the pulley to the required position for alignment.
3. Tighten hub bolts to secure pulley on shaft.
4. Check belt tension
5. Close and secure guards.

### **Drive Belt Replacement**

1. Lower motor to its lowest position.
2. Remove old belt and replace with a new one.
3. Raise motor to set the belt tension.
4. Check pulley alignment. Adjust if required.
5. Close and secure guards.

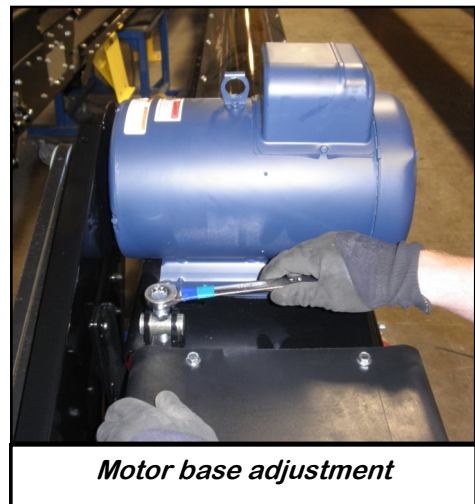

*Motor base adjustment*



*Lay a straightedge across*

**SECTION  
G**

**BELT TENSIONING SPECIFICATION**

V-Belt tensioning adjustment can be made using a tension meter or other type spring scale using the following procedure. After seating the belts in the groove and adjusting center distance so as to take up the slack in the belts, further increase the tension until only a slight bow on the slack side is apparent while the drive is operating under load. Stop the drive and using the meter, measure the force necessary to depress one of the center belts 1/64 inch for every inch of belt span (see sketch below). For example, a deflection for a 50 inch belt span is 50/64 or 25/32 inch. The amount of force required to deflect the belt should compare with the deflection forces noted in the table below. Also notice for V- Belts that deflection forces vary from the initial RUN - IN values which are greater (reflecting higher run-in tensioning) to the NORMAL values for after the run-in period.

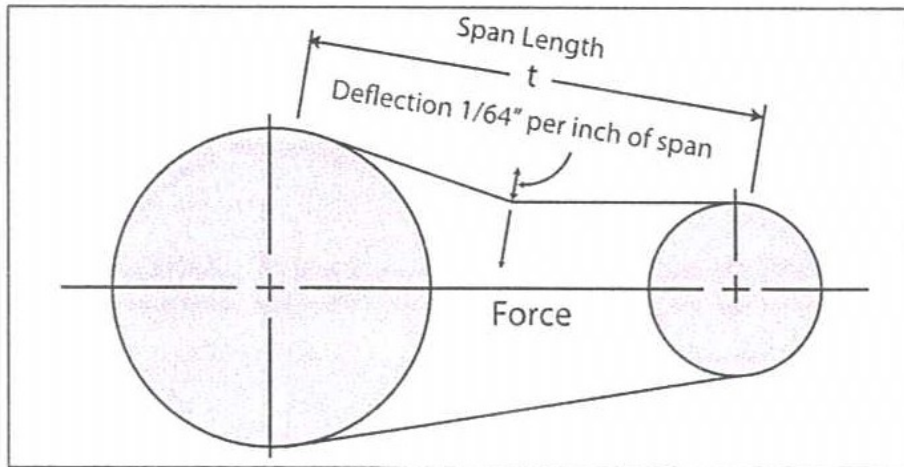

MEASURE THE SPAN LENGTH "T" AS SHOWN IN THE SKETCH ABOVE.

BELT CROSS SECTION	SMALLER PULLEY DIAMETER RANGE (inches)	DEFLECTION FORCE	
		RUN - IN (lbs)	NORMAL (lbs)
AX	3.0 - 3.6	4 - 1/8	2 - 3/4
	3.8 - 4.8	5	3 - 1/4
	5.0 - 7.0	6	4
BX	3.4 - 4.2	5 - 1/4	3 - 1/2
	4.4 - 5.2	7 - 1/8	4 - 3/4
	5.4 - 9.4	9	6



When storing the Tri - Flo ® System for long periods of time, the following procedures must be followed to reduce the chance of rust, corrosion and fatigue of the Tri - Flo ® System. You can also use these steps when storing the machine for the winter.



A dust mask and protective rubber gloves shall be used when cleaning the machine.

---

### **UNDERBIN CONVEYOR**

1. Disconnect power.
2. Thoroughly wash the entire machine to remove all dirt, mud, debris or residue.
3. Remove yellow covers and remove any debris or build-up.
4. Remove clean out doors and thoroughly remove any debris or build-up inside of the conveyor. Ensure that the bottom pan of the underbin conveyor is free of seed.
5. Lubricate all grease fittings and chain. Make sure that all grease cavities have been filled with grease to remove any water residue from the washing. This also protects the bearing seals.
6. Re-connect power and run the underbin conveyor to help remove any additional debris. Compressed air can be used to blow out any foreign material.
7. Cover the electric motor with a water proof tarpaulin and tie securely in place.

---

### **TRI-FLO® WEIGH HOPPER & SLIDE GATE**

1. Thoroughly clean the weigh hopper to remove all residue from the equipment.
2. Clean the slide gate of any seed or residue that may have built up.

---

### **SCALE FILL CONVEYOR**

1. Disconnect power.
2. Thoroughly wash the entire machine to remove all dirt, mud, debris or residue.
3. Remove yellow covers and remove any debris or build-up.
4. Remove clean out doors and thoroughly remove any debris or build-up inside of the conveyor.

### **SCALE FILL CONVEYOR**

5. Lubricate all grease fittings and chain. Make sure that all grease cavities have been filled with grease to remove any water residue from the washing. This also protects the bearing seals.
  6. Re-connect power and run the scale fill conveyor to help remove any additional debris. Compressed air can be used to blow out any foreign material.
  7. Cover the electric motor with a water proof tarpaulin and tie securely in place.
- 

### **PRO BOX HOPPER & TRANSFER CONVEYOR (optional)**

1. Disconnect power.
  2. Thoroughly wash the entire machine to remove all dirt, mud, debris or residue.
  3. Remove yellow covers and remove any debris or build-up.
  4. Remove clean out doors and thoroughly remove any debris or build-up inside of the conveyor.
  5. Lubricate all grease fittings and chain. Make sure that all grease cavities have been filled with grease to remove any water residue from the washing. This also protects the bearing seals.
  6. Re-connect power and the transfer conveyor to help remove any additional debris. Compressed air can be used to blow out any foreign material.
  7. Cover the electric motor with a water proof tarpaulin and tie securely in place.
  8. Tarp or place the cover on top of the pro box hopper to keep out any dirt or unwanted pests.
- 

### **FINAL**

1. Store all portable components of the Tri - Flo ® System inside a protective building to keep them from being exposed to the weather.
2. Disconnect power to the machine and all of the components.
3. Ensure all moisture has been removed from the airlines.
4. Disconnect the supply air line to the bottom of the solenoid bank and place a plug in the fitting to keep moisture out of the system.

# MECHANICAL DRAWINGS

## SECTION I

<u>Contents</u>	<u>Page #</u>
Assemblies Common to Multiple Versions .....	56
Standard Tri-Flo® C2D2 (Version 3) .....	67
Standard Tri-Flo® (Version 4) .....	82
High Capacity Tri-Flo® (Version 4HC).....	94

**FORKLIFT BRACKET ASSEMBLY (13-05-0268) ALL VERSIONS**

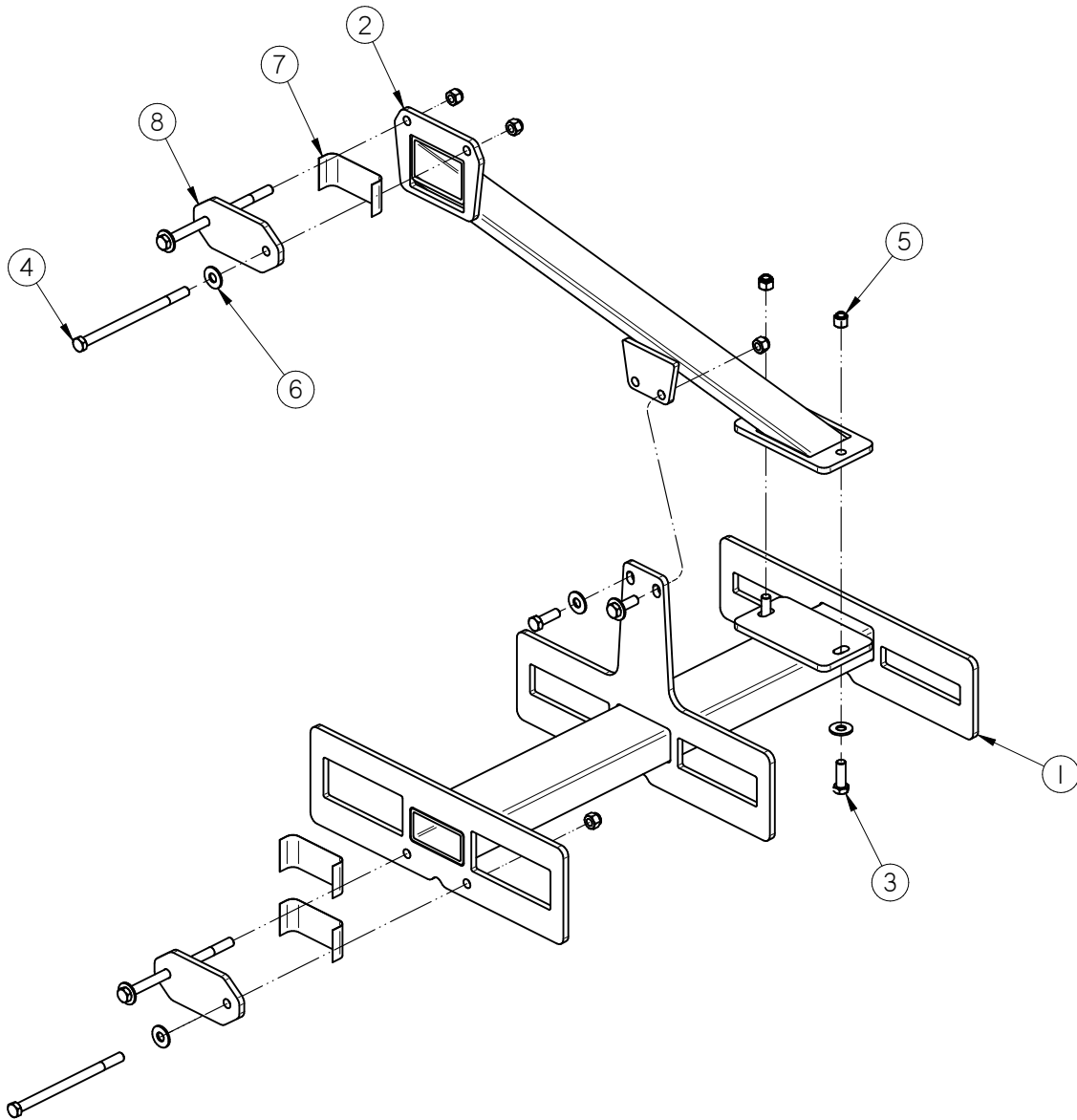

Item #	Part #	Description	Qty
1	05-09-0043	WDMT FORK PCKT BASE	1
2	05-09-0044	WDMT FORK PCKT BRACE	1
3	06-01-0025	BOLT .500-13 X 1.50 ZP GR5	4
4	06-01-0268	BOLT .500-13 X 8.00 ZP GR5	4
5	06-03-0004	NUT NYL LOCK .500-13 ZP GR5	8
6	06-05-0005	WSHR FLAT .500 ZP	8
7	08-07-0048	TAPE ANTI-SLIP 2.00" X 6.00"	3
8	102D5F	PLT CLAMP BASE	2

**WEIGHT CALIBRATION BAR ASSEMBLY (13-05-0263) VERSION 3 AND 4**

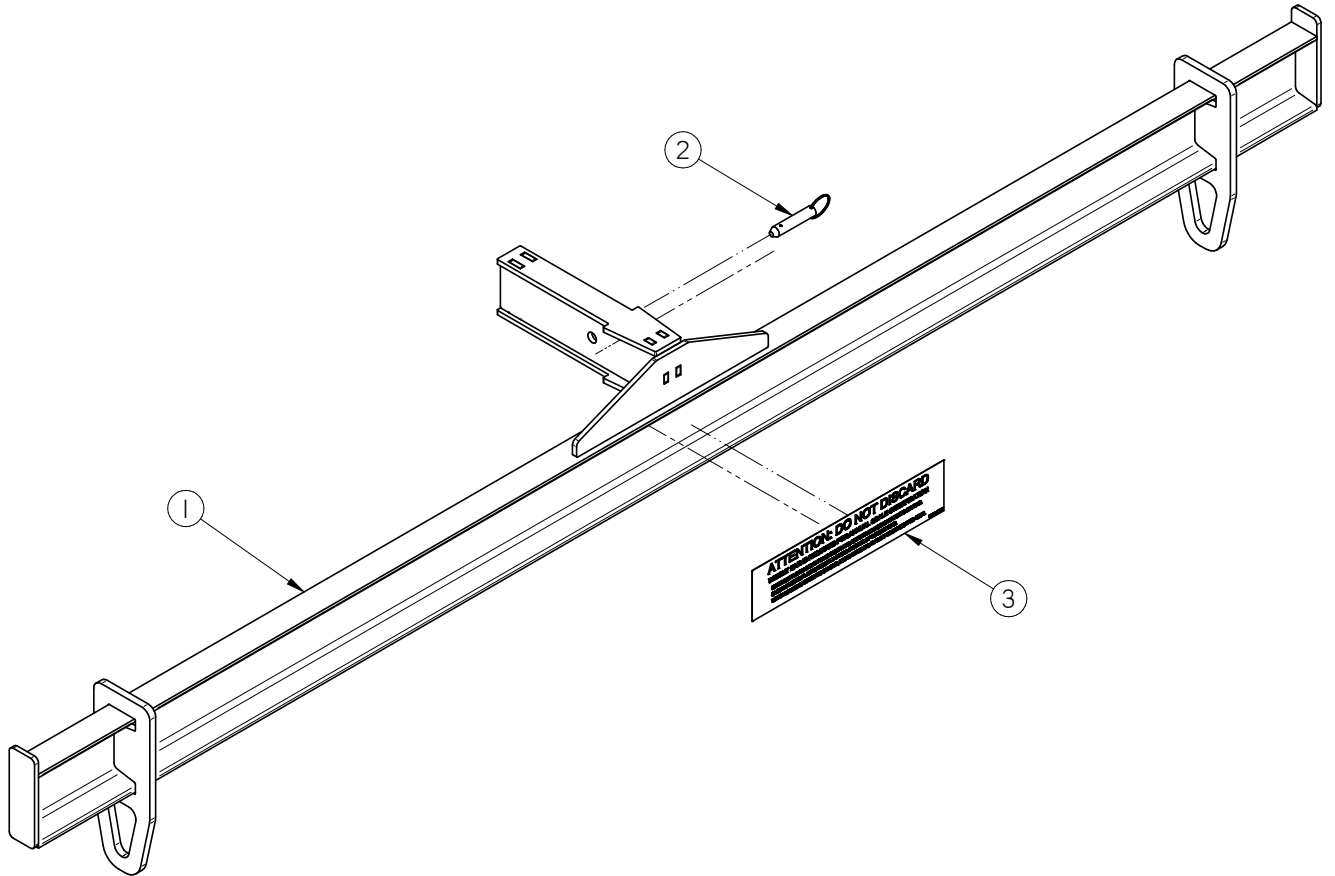

Item #	Part #	Description	Qty
1	05-09-0040	WDMT WEIGHT BAR TRI-FLOW	1
2	06-09-0070	PIN SPGLD QCK REL RING GRIP 0.5DIA	1
3	09-02-0017	LBL ATWRK ATT WGHT BAR TRI-FL	1

**HIGH LEVEL SENSOR ASSEMBLY (05-07-0762) VERSION 3**

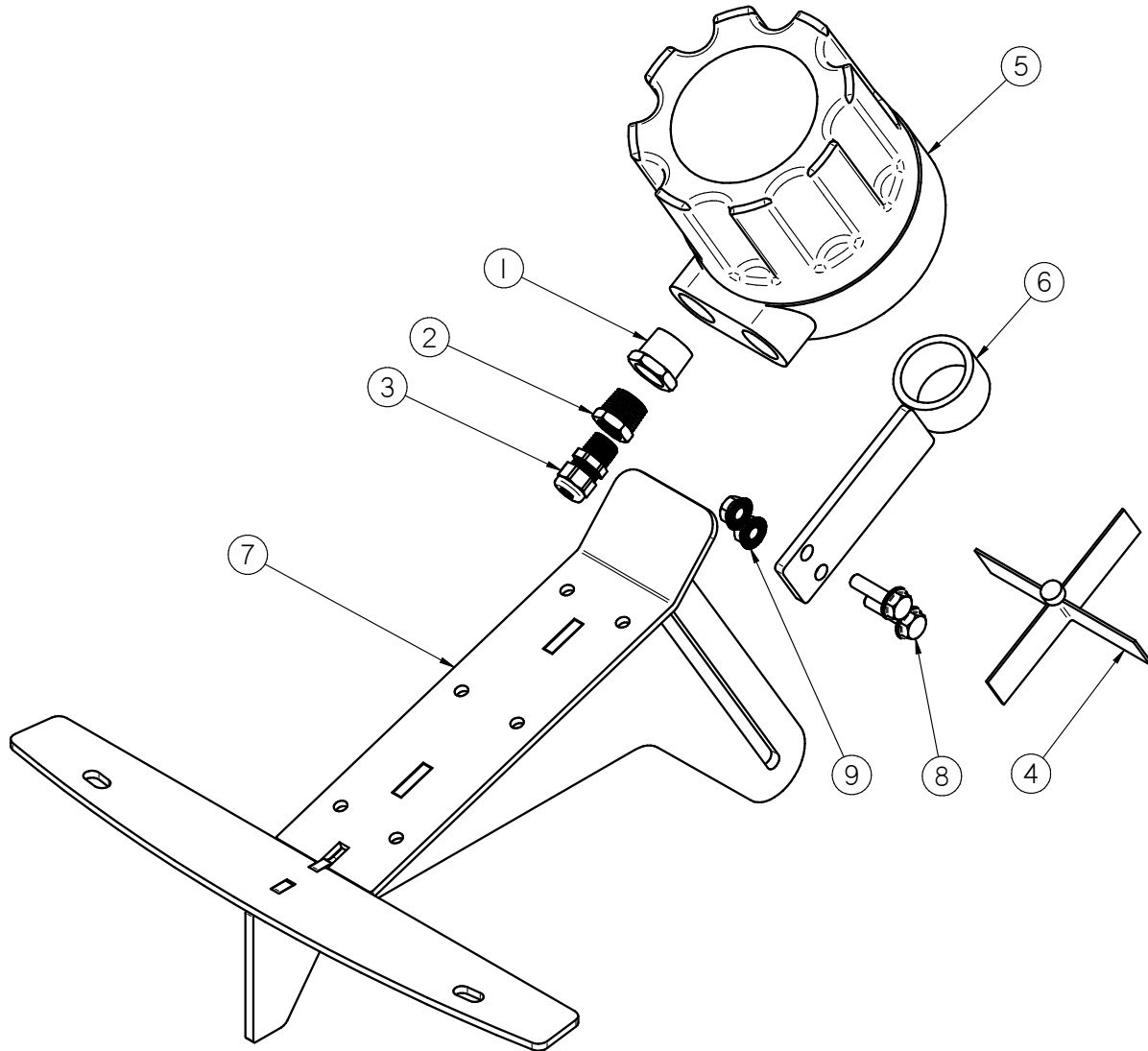

Item #	Part #	Description	Qty
1	02-04-0008	FTTG BUSH .750NPT X .500NPT SS	1
2	02-05-0017	FTTG BUSH .500NPT X .375NPT SS	1
3	03-08-0298	CONN CG .375NPT .115-.312 3229LTF	1
4	03-19-0017	PDL 4 VANE LVL INDI PAN 1-4156	1
5	03-19-0072	SW LVL INDI MDL KAX2SPDT 24VDC	1
6	05-04-0115	WDMT LVL INDI AD	1
7	05-04-0175	WDMT BRUT LVL INDI AD	1
8	06-01-0189	BOLT, FLAG .375-16 UNC ZP GRADE 5; 1-1/4" LG	2
9	06-03-0014	NUT LOCK FLAG .375-16 ZP GR5	2



**SLIDE GATE VALVE ASSEMBLY (05-07-0969) VERSION 4 AND 4HC**

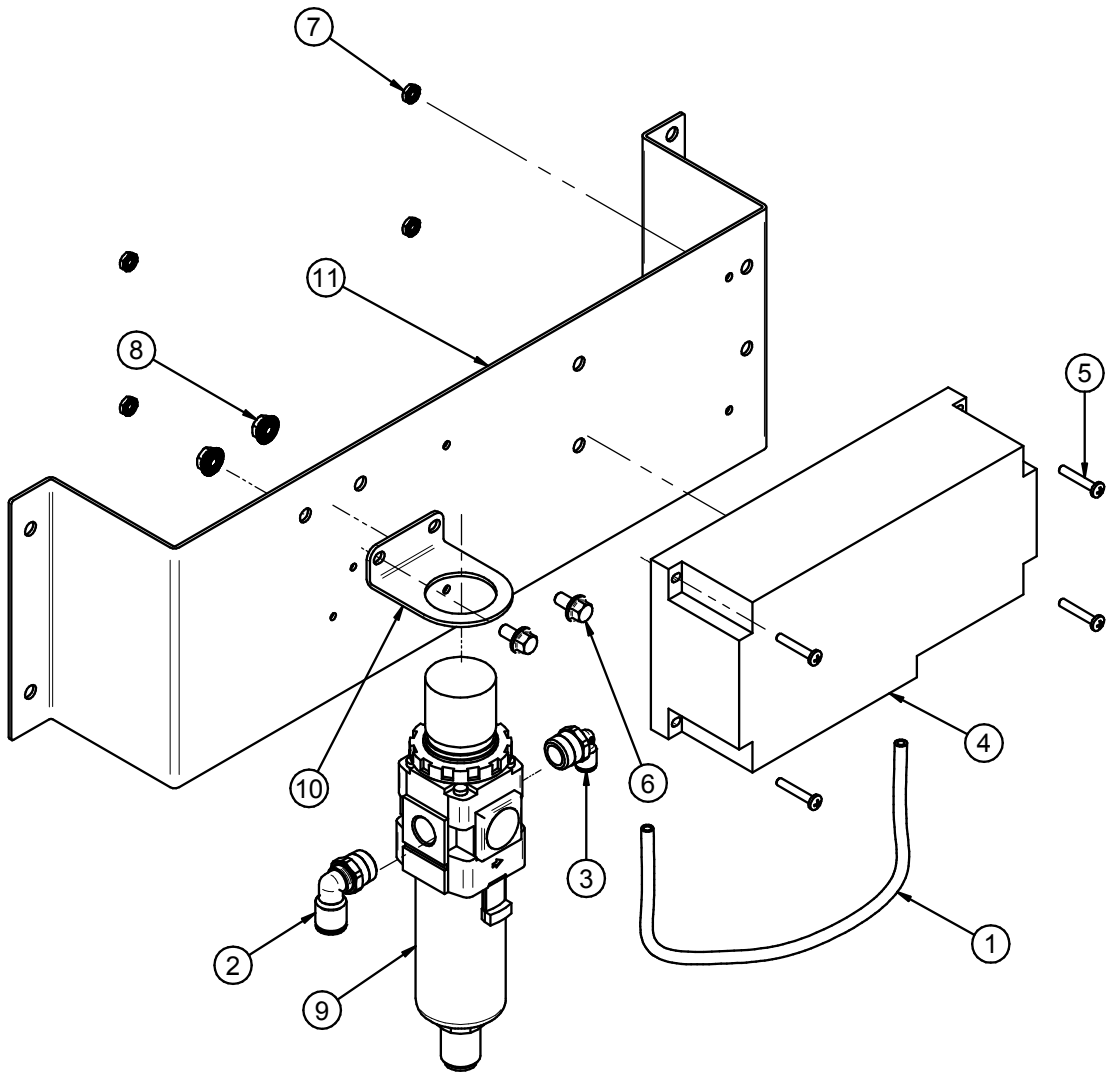

Item #	Part #	Description	Qty
1	02-03-0051	TBG .250 OD NYL BLK 14 IN LG	1
2	02-16-0036	FTTG PUSH 90DEG .375OD X.375 NPT ML	1
3	02-16-0049	FTTG PUSH 90 DEG .25 OD X .375 NPT	1
4	03-17-0145	VLV SOL SMC MANIFOLD TRIFLO V4 ASSY	1
5	06-01-0094	SCRW PAN HD 8-32 X 1.00 ZP	4
6	06-01-0299	BOLT FLAG .250-20 X .500 ZP GR5	2
7	06-02-0034	NUT 8-32 K-LOCK ZP	4
8	06-03-0013	NUT,LOCK, FLAG .250-20 ZP SERRATED	2
9	07-03-0023	REGULATOR W/FLTR & DRAIN .375 NPT	1
10	07-03-0026	REGL BRACKET AR33P-270AS	1
11	105BF0	PLT VLV MNT SMC TRI-FLO	1

**HOPPER EXTENSION ASSEMBLY (13-05-0270) VERSION 3 AND 4**

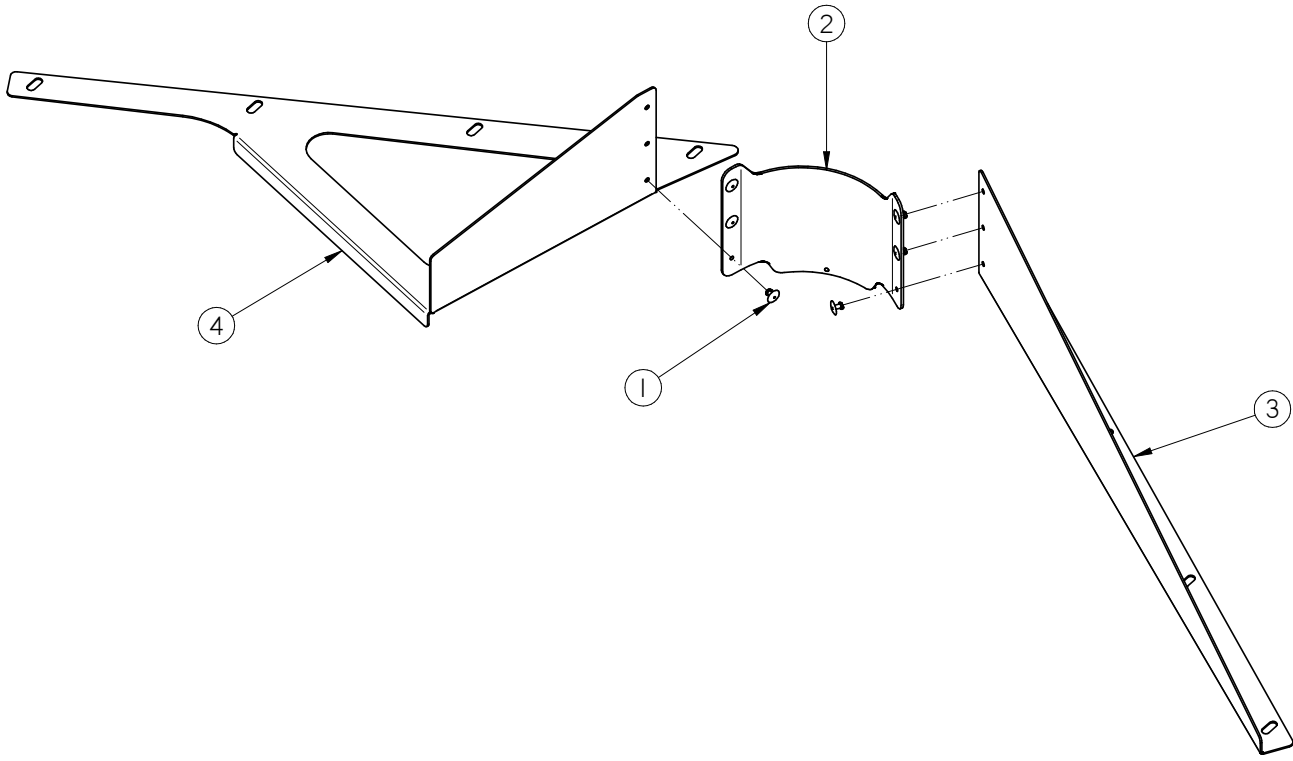

Item #	Part #	Description	Qty
1	06-12-0022	RIVET POP .188 X .312 GRIP SS .65HD	6
2	102D99	RBBR HOPP EXT MTR	1
3	102D9A	PLT HOPP EXT RH	1
4	102D9C	PLT HOPP EXT MTR	1

**HOPPER 1 ASSEMBLY (05-07-0759) VERSION 3 AND 4**

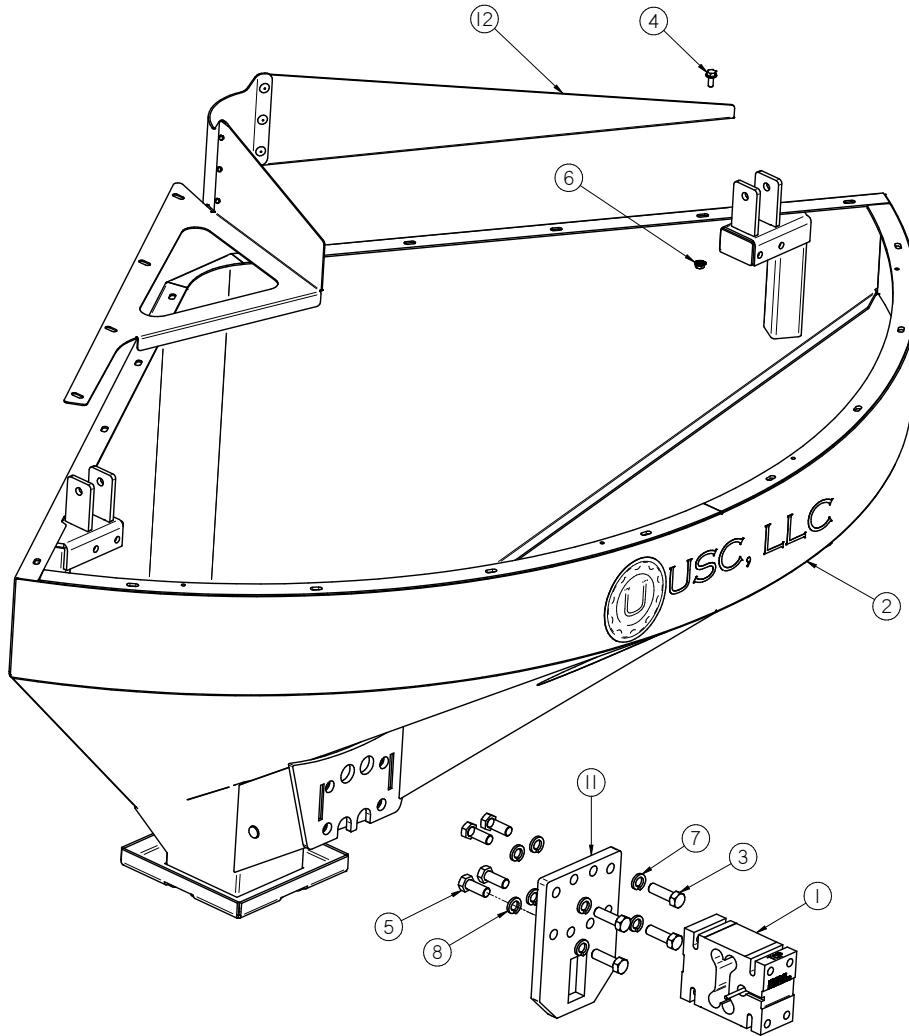

Item #	Part #	Description	Qty
1	03-19-0042	LDCL VISHAY 1320 2200LB CLASS III	1
2	05-03-1032	WDMT HOPP WEDGE 30 UNIT OPEN TOP	1
3	06-01-0032	BOLT, .625 X 11 X 2" UNC ZP GRADE 5	4
4	06-01-0138	BOLT, FLAG .3125-18 UNC ZP GRADE 5; 3/4" LG	8
5	06-01-0228	BOLT M16-2.00 X 40MM FTH	4
6	06-03-0019	NUT LOCK FLAG .3125-18 ZP GR5	8
7	06-04-0005	WASHER, .625 LOCK ZP	4
8	06-04-0018	WSHR LOCK SPLT M16 ZP	4
9	09-01-0043	ATWL LBL USC, LLC 6" X 19" PRO-CUT	1
10	09-02-0019	LBL ATWRK TRI-FLO LOGO	1
11	102349	PLT LDCL ATTACH	1
12	13-05-0270	ASSY HOPP EXT MTR	1

**HOPPER EXTENSION ASSEMBLY (13-05-0271) VERSION 3 AND 4**

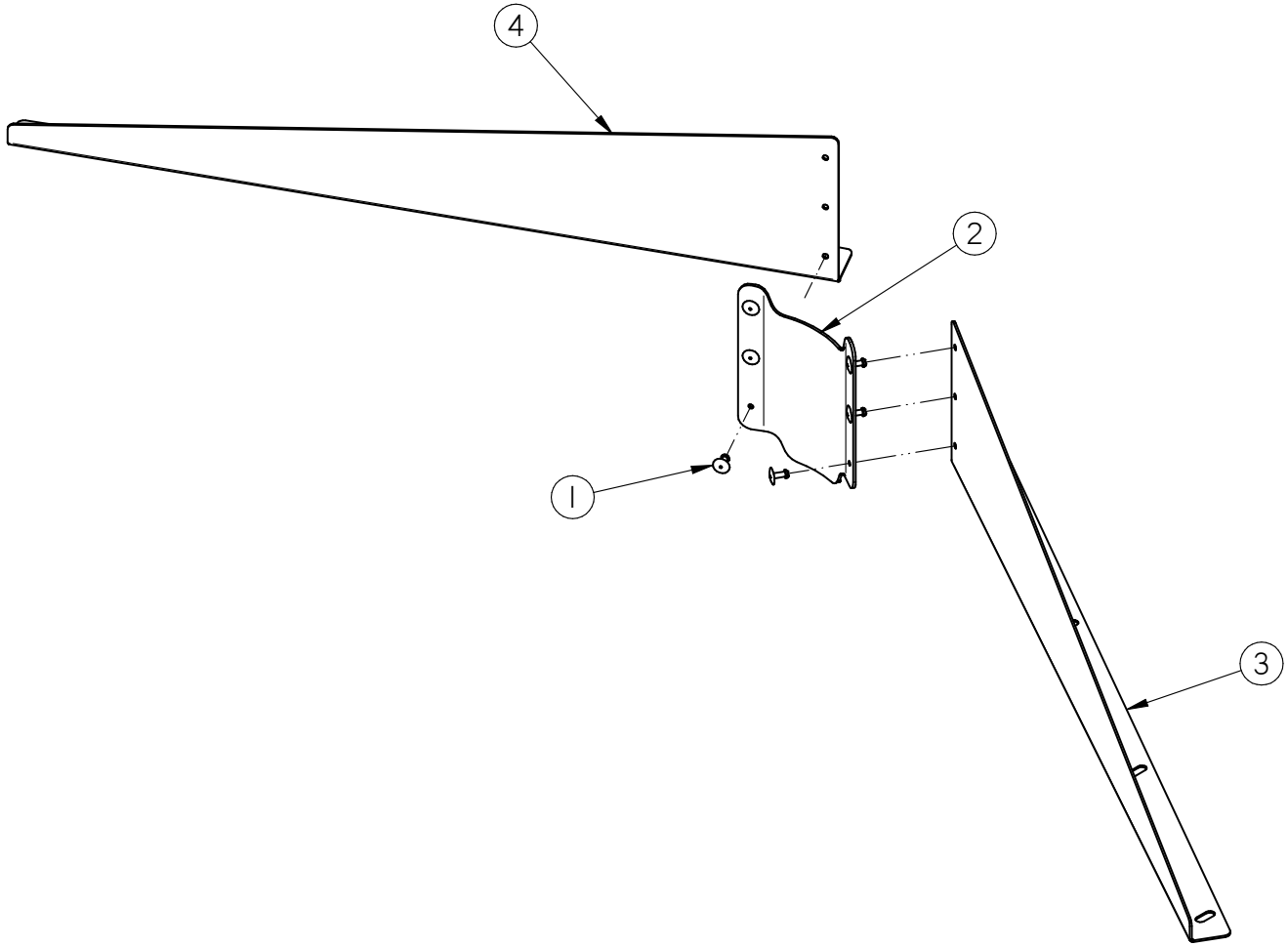

Item #	Part #	Description	Qty
1	06-12-0022	RIVET POP .188 X .312 GRIP SS .65HD	6
2	102D98	RBBR HOPP EXT	1
3	102D9A	PLT HOPP EXT RH	1
4	102D9B	PLT HOPP EXT LH	1

**HOPPER 2 & 3 ASSEMBLY (05-07-0760) VERSION 3 AND 4**

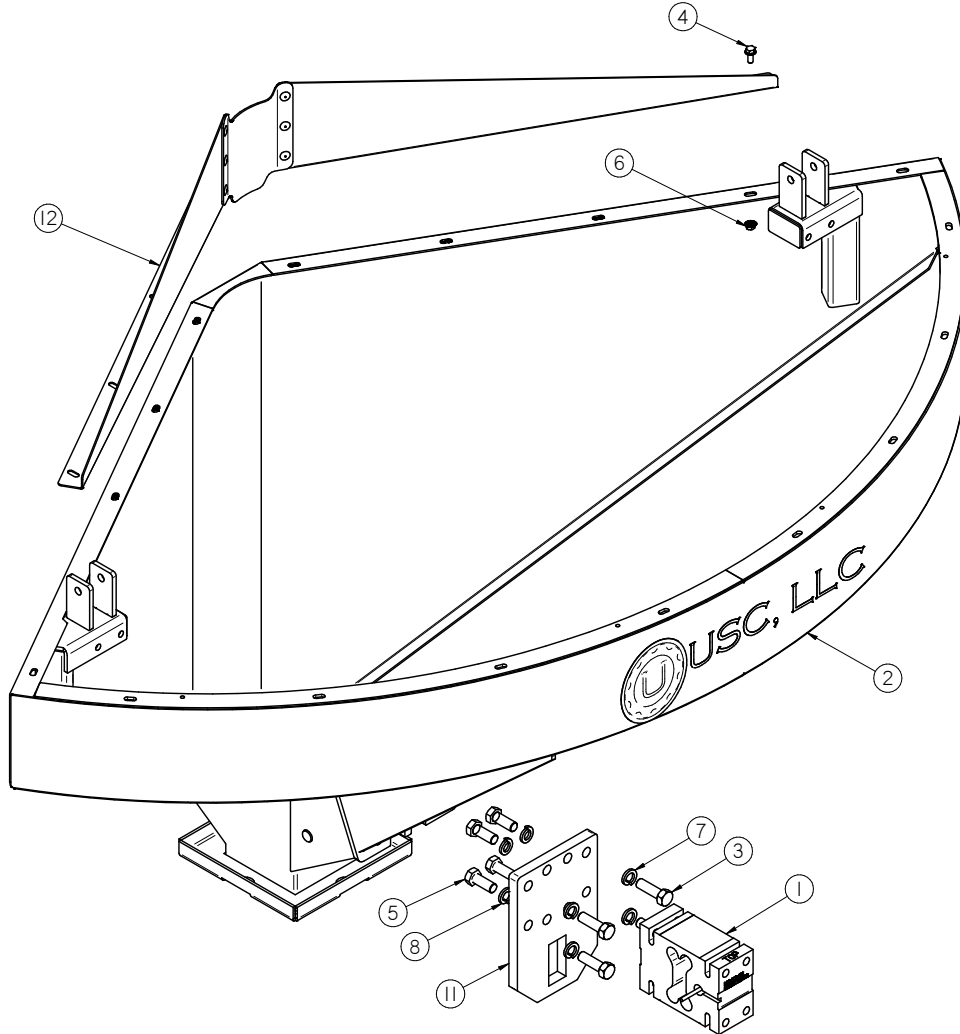

Item #	Part #	Description	Qty
1	03-19-0042	LDCL VISHAY 1320 2200LB CLASS III	1
2	05-03-1032	WDMT HOPP WEDGE 30 UNIT OPEN TOP	1
3	06-01-0032	BOLT, .625 X 11 X 2" UNC ZP GRADE 5	4
4	06-01-0138	BOLT, FLAG .3125-18 UNC ZP GRADE 5; 3/4" LG	8
5	06-01-0228	BOLT M16-2.00 X 40MM FTH	4
6	06-03-0019	NUT LOCK FLAG .3125-18 ZP GR5	8
7	06-04-0005	WASHER, .625 LOCK ZP	4
8	06-04-0018	WSHR LOCK SPLT M16 ZP	4
9	09-01-0043	ATWL LBL USC, LLC 6" X 19" PRO-CUT	1
10	09-02-0019	LBL ATWRK TRI-FLO LOGO	1
11	102349	PLT LDCL ATTACH	1
12	13-05-0271	ASSY HOPP EXT	1

**SERVO DRIVE ASSEMBLY (05-07-0757) VERSION 3 AND 4**

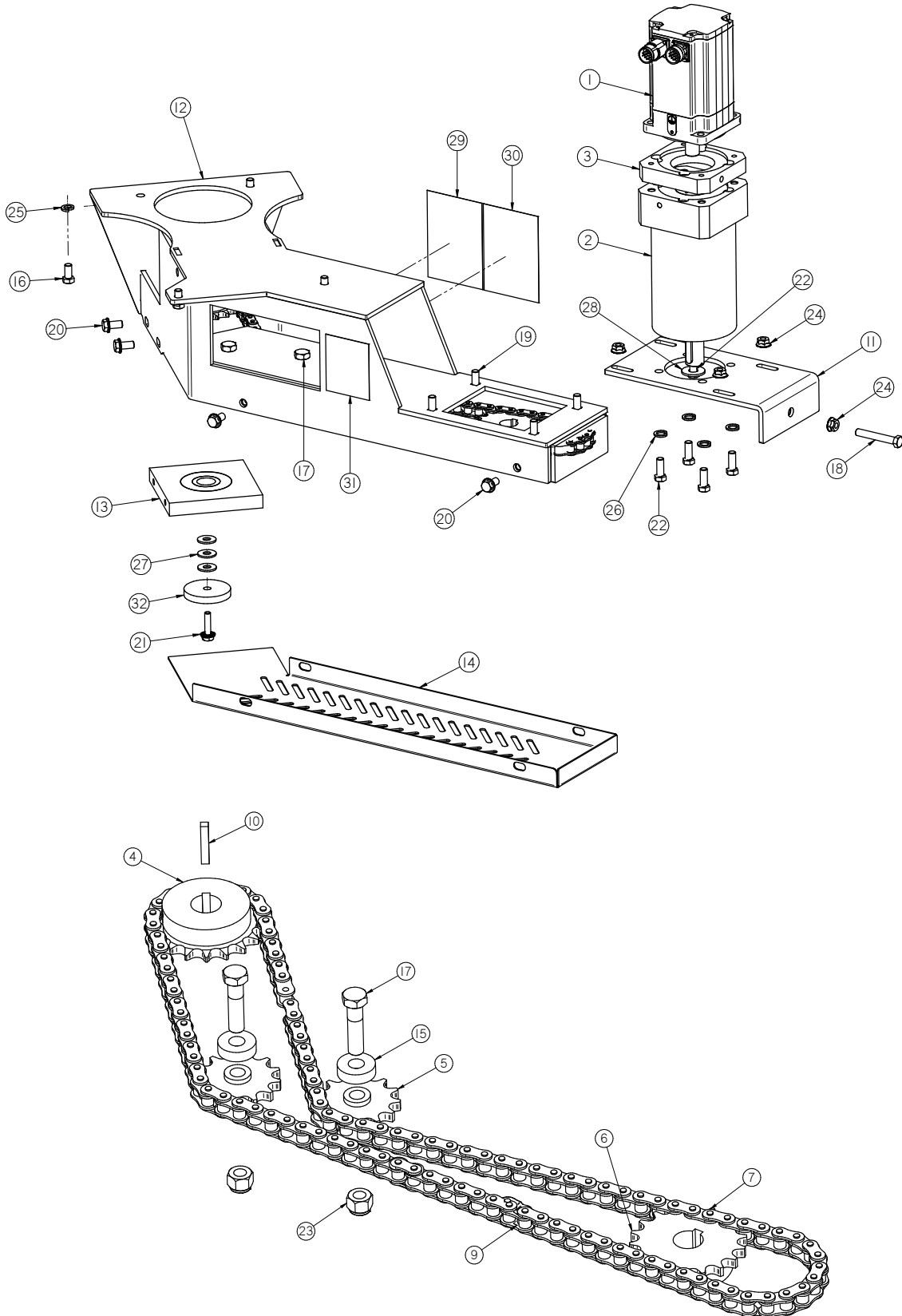



**SERVO DRIVE ASSEMBLY (05-07-0757) VERSION 3 AND 4**

Item #	Part #	Description	Qty
1	01-01-0203	SERVO MTR BMH1002T07A2A	1
2	01-01-0204	SERVO MTR GEARBOX 120MM RATIO 40	1
3	01-01-0205	SERVO MTR GEARBOX KIT SIZE 120 BMH	1
4	01-02-0096	SPKT #50 18T WITH 1 FNSH BORE	1
5	01-02-0115	SPKT 13T 50P .500ID IDLER	2
6	01-02-0122	SPKT 18T 50P 25MM BORE 8MM KEYWAY	1
7	01-04-0002	CHAIN RLR 50	1
8	01-04-0005	CHAIN CTNG LINK 50P	1
9	01-04-0007	#50 OFFSET LINK	1
10	01-10-0005	1/4" KEY, CS - 1 1/2" LONG	1
11	05-03-1523	WDMT BRUT GBOX MNT SERVO DRV	1
12	05-04-0098	WDMT SLTR DRV CNTNS FLOW SYSTEM	1
13	05-04-0120	ASSY LOWER SHAFT CNTNS FLOW SYSTEM	1
14	05-10-3749	GRD SLTR CHAIN DRV	1
15	05-10-3811	WSHR .500 ID X 1.25 OD X .375 THK	2
16	06-01-0015	BOLT .375-16 X 0.75 ZP GR5	4
17	06-01-0027	BOLT .500-13 X 2.00 ZP GR5	2
18	06-01-0071	BOLT .375-16 X 2.50 ZP GR5	1
19	06-01-0115	BOLT CRG .375-16 X 1.00 ZP GR5	4
20	06-01-0124	BOLT FLAG .375-16 X .750 ZP GR5	8
21	06-01-0189	BOLT FLAG .375-16 X 1.250 ZP GR5	1
22	06-01-0295	BOLT M10-1.5 X 25MM ZP	5
23	06-03-0004	NUT NYL LOCK .500-13 ZP GR5	2
24	06-03-0014	NUT LOCK FLAG .375-16 ZP GR5	5
25	06-04-0003	WSHR LOCK SPLT .375 ZP	4
26	06-04-0011	WASHER, .4375 LOCK ZP	4
27	06-05-0004	WSHR FLAT .375 ZP	3
28	06-05-0020	WASHER, .4375 FLAT ZP	1
29	09-02-0001	ATWK LBL DANGER FINGERS	1
30	09-02-0002	ATWK LBL DANGER GUARDS	1
31	09-02-0009	ATWK LBL WARNING ROTATING PARTS	1
32	10224D	WSHR	1

**HIGH LEVEL SENSOR ASSEMBLY (05-07-0974) VERSION 4 AND 4HC**

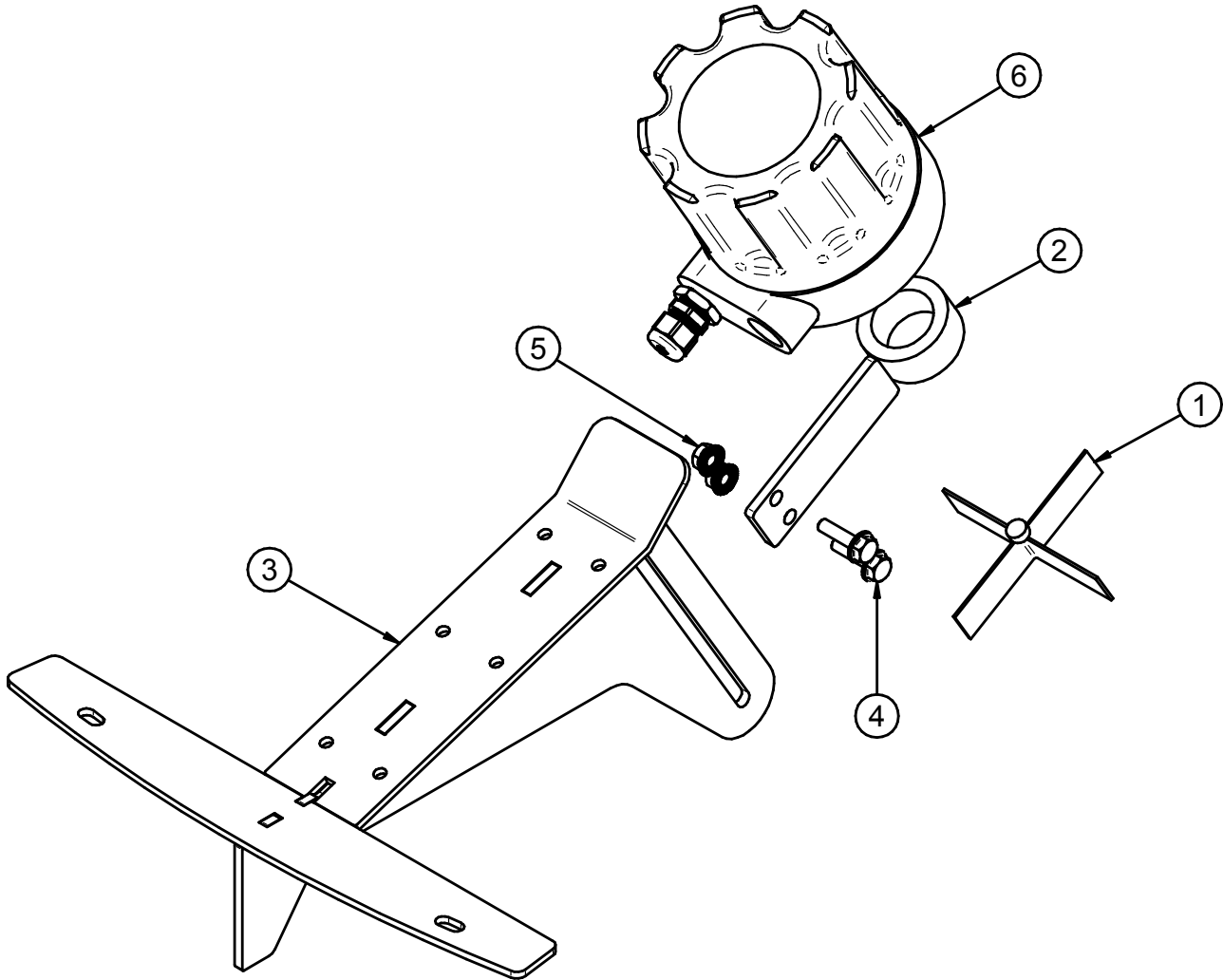

Item #	Part #	Description	Qty
1	03-19-0017	PDL 4 VANE LVL INDI PAN 1-4156	1
2	05-04-0115	WDMT LVL INDI AD	1
3	05-04-0175	WDMT BRUT LVL INDI AD	1
4	06-01-0189	BOLT FLAG .375-16 X 1.250 ZP GR5	2
5	06-03-0014	NUT LOCK FLAG .375-16 ZP GR5	2
6	13-04-0250	KIT SW LVL INDI TRI-FLO V4	1

**PRINTER MOUNTING BRACKET ASSEMBLY (13-10-0019) VERSION 3**

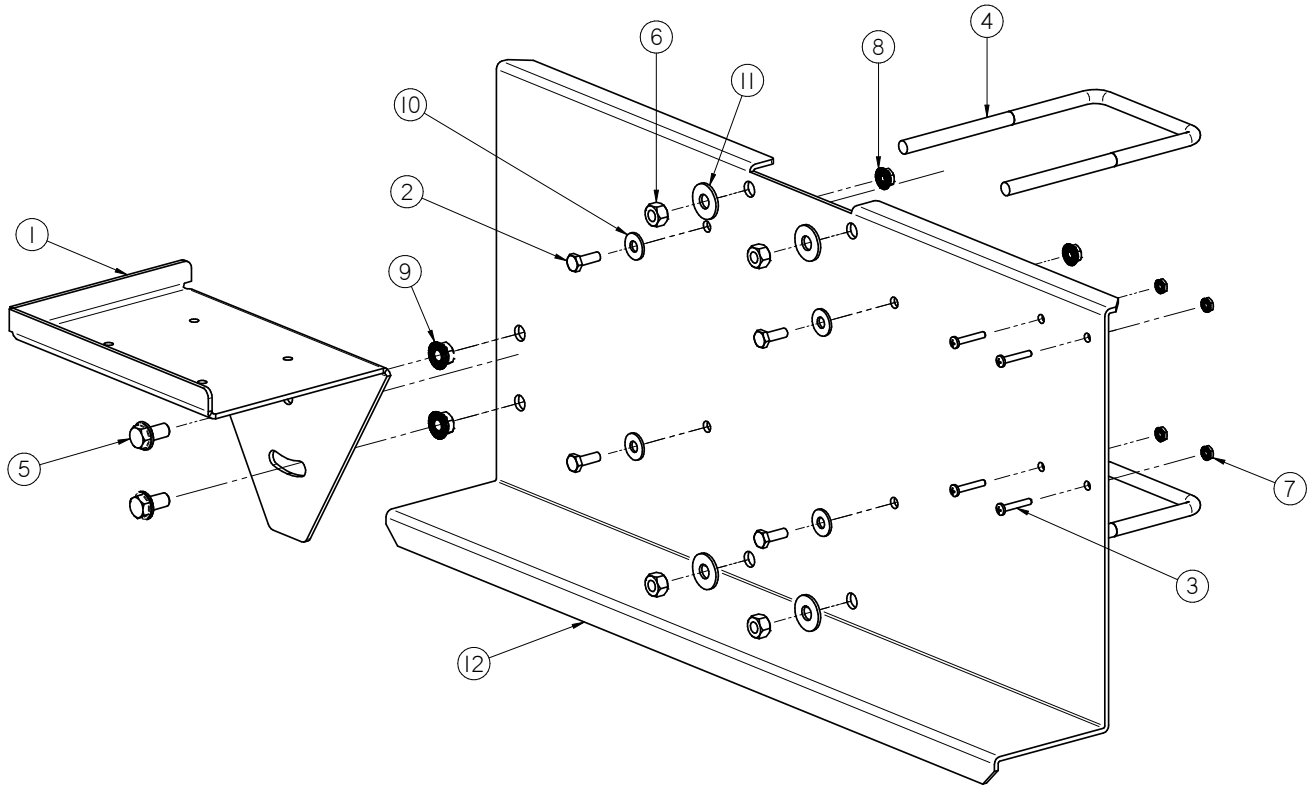

Item #	Part #	Description	Qty
1	05-10-3229	BRUT LX PRINTER SHELF	1
2	06-01-0006	BOLT .250-20 X .750 ZP GR5	4
3	06-01-0094	SCRW PAN HD 8-32 X 1.00 ZP	4
4	06-01-0113	BOLT U .375-16 X 4.00 X 6.625 ZP	2
5	06-01-0124	BOLT FLAG .375-16 X .750 ZP GR5	2
6	06-02-0003	NUT FULL .375-16 ZP GR5	4
7	06-02-0034	NUT 8-32 K-LOCK ZP	4
8	06-03-0013	NUT, LOCK, FLAG .250-20 ZP SERRATED	4
9	06-03-0014	NUT LOCK FLAG .375-16 ZP GR5	2
10	06-05-0001	WASHER, FLAT .250	4
11	06-05-0004	WSHR FLAT .375 ZP	4
12	10229C	BRUT INDI PNTR ESTP	1

**AIR MANIFOLD ASSEMBLY (05-07-0758) VERSION 3**

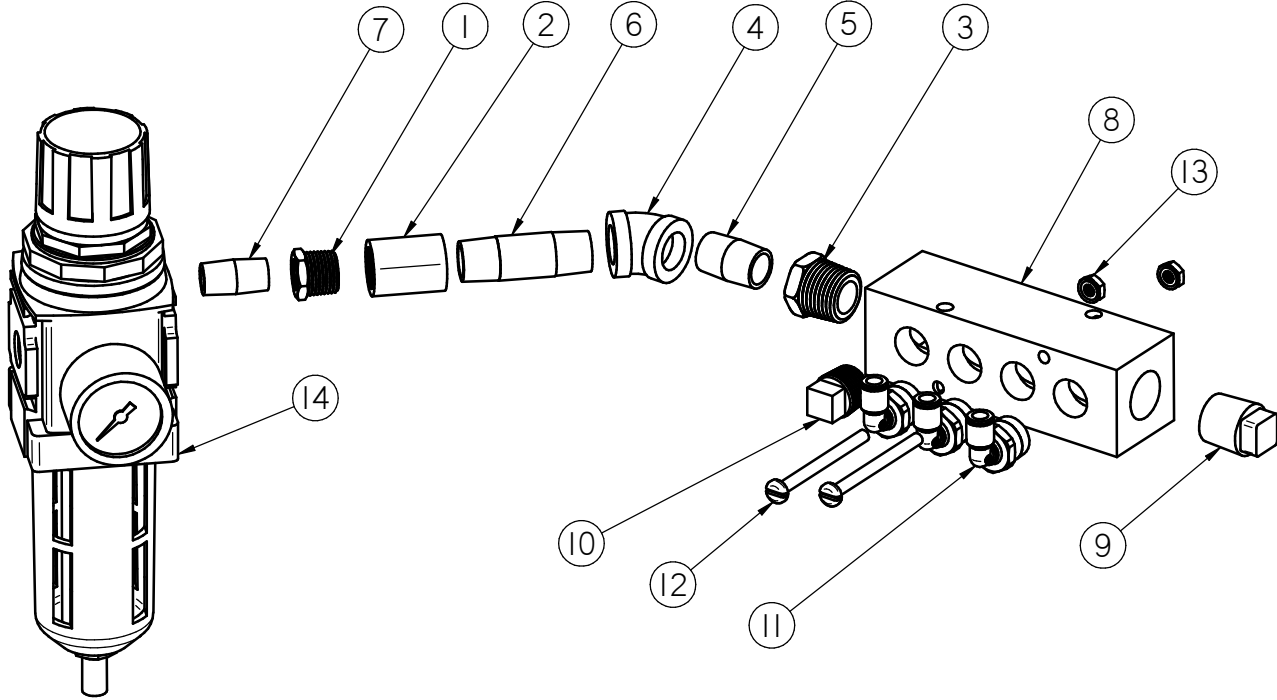

Item #	Part #	Description	Qty
1	02-04-0010	FTTG BUSH .375NPT X .250NPT BRSS	1
2	02-05-0004	FTTG CPLG .375 NPT X 1.50 FM SS	1
3	02-05-0017	REDUCER .500NPT X .375 NPT 304SS	1
4	02-06-0007	ELBOW, .375-18 NPT, 45 DEG. SS	1
5	02-07-0001	NIPPLE, .375 NPT SCH. 40 304 SS	1
6	02-07-0003	FTTG NIP .375 NPT X 2.00 TBE SS	1
7	02-07-0018	NIPPLE, .250-18 NPT, SCH. 40 SS, 1.0	1
8	02-09-0019	FTTG MNFLD 4X.375NPTX.500NPT ALUM	1
9	02-14-0001	FTTG PLUG SQHD .500 NPT SS	1
10	02-14-0006	PLUG 3/8" NPT SS SQ HEAD	1
11	02-16-0049	FTTG PUSH 90 DEG .25 OD X .375 NPT	3
12	06-01-0203	SCRW MACH 10-32 X 2.25 ZP SLTD RD	2
13	06-02-0030	NUT KLOCK 10-32 ZP	2
14	07-03-0013	REGL DIAL FLTR DRAIN .25 NPT	1

**SLIDE GATE VALVE ASSEMBLY (05-07-0761) VERSION 3**

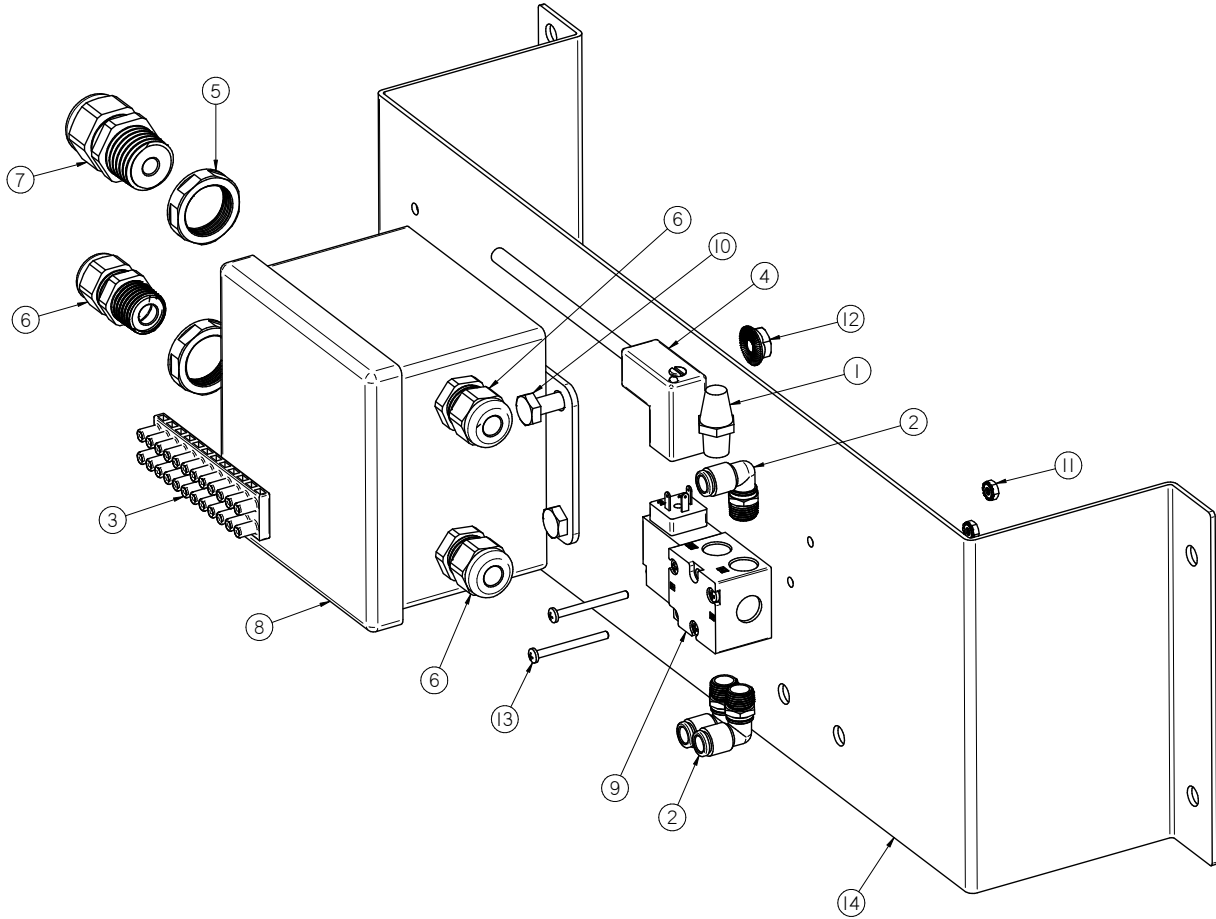

Item #	Part #	Description	Qty
1	02-02-0049	FLTR EXHAUST BRZ .125 NPT	1
2	02-16-0046	FTTG PUSH 90 DEG .250 OD X .125 NPT	3
3	03-05-0042	TMNL BARRIER STRIP IDEAL 89-608	1
4	03-07-0110	CBL PWR SELINOID 3M BLK	1
5	03-08-0308	NUT NYLOC .500 NPT 8464	4
6	03-08-0338	CONN CG .5 NPT M4520 RLTCG HEYCO	3
7	03-08-0387	CONN CG .5 NPT M4518 RLTCG HEYCO	1
8	03-11-0158	ENCL 4X4X3 SCE-404SC SCE-09 GRAY	1
9	03-17-0080	VLV SOL MAC 45A-AA1-DDAJ-1KJ	1
10	06-01-0004	BOLT, .250-20 X .500 UNC ZP GRADE 5	4
11	06-02-0052	NUT LOCK 4-40 CS MMC# 90675A005	2
12	06-03-0013	NUT,LOCK, FLAG .250-20 ZP SERRATED	4
13	06-06-0079	SCRW MACH 4-40 X1.25 PHLP PHD	2
14	105BF0	PLT VLV MNT SMC TRI-FLO	1

**SLIDE GATE ASSEMBLY (12-04-0023) VERSION 3**

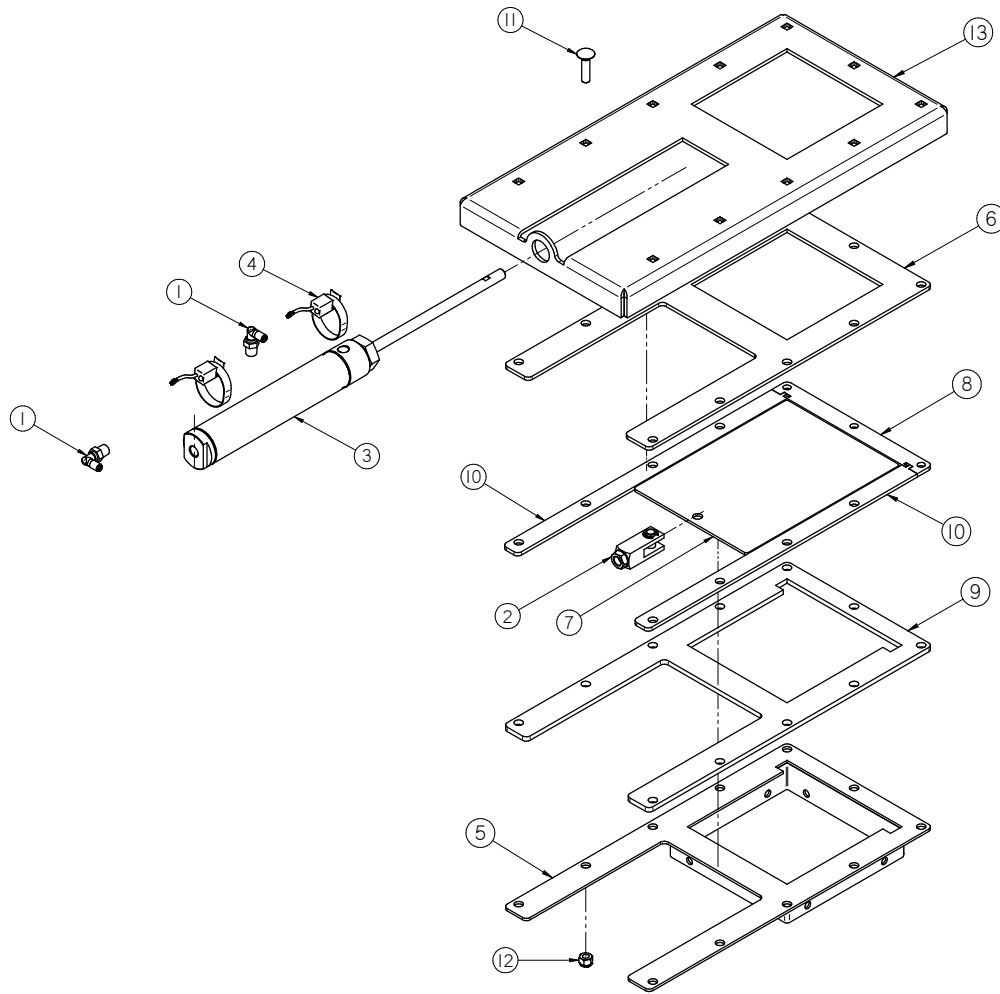

Item #	Part #	Description	Qty
1	02-16-0044	FTTG PUSH 90 DEG .250OD X .250 NPT	2
2	03-17-0041	CLEVIS ASSY BIMBA D-8313-A	1
3	03-17-0093	BIMBA AIR CYL 1.75 X 7 M-247-DP	1
4	03-17-0094	SW MAG REED MRS-.087-PXBL-24S	2
5	05-07-0370	WDMT DSCHG 6.00IN SQ SLGT	1
6	05-10-3751	PLT SLGTUHMW TOP 6.00IN SQ	1
7	05-10-3752	PLT SLGT 6.00IN SQ	1
8	05-10-3753	STOP UHMW SLGT 6.00IN SQ	1
9	05-10-3754	PLT UHMW LOWER SLGT 6.00IN SQ	1
10	05-10-3755	GUIDE UHMW SIDE SLGT 6.00IN SQ	2
11	06-01-0128	BOLT CRG .375-16 X 1.50 ZP GR5	7
12	06-03-0003	NUT NYL LOCK .375-16 ZP GR5	7
13	102ACC	PLT SLGT BODY 6.00IN SQ	1



**DISTRIBUTION DRIVE ASSEMBLY (05-07-0756) VERSION 3**

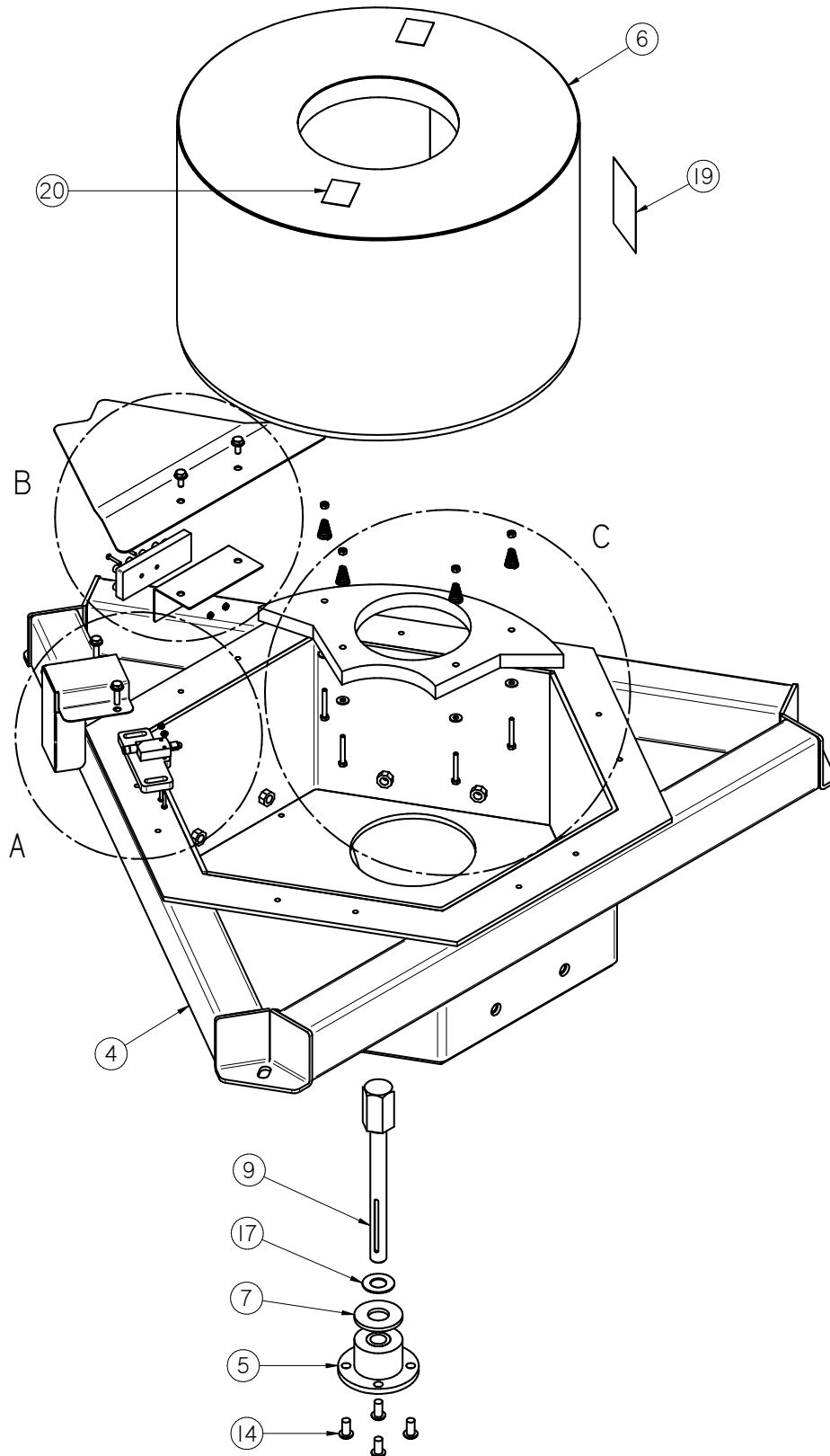

**DISTRIBUTION DRIVE ASSEMBLY (05-07-0756) VERSION 3**

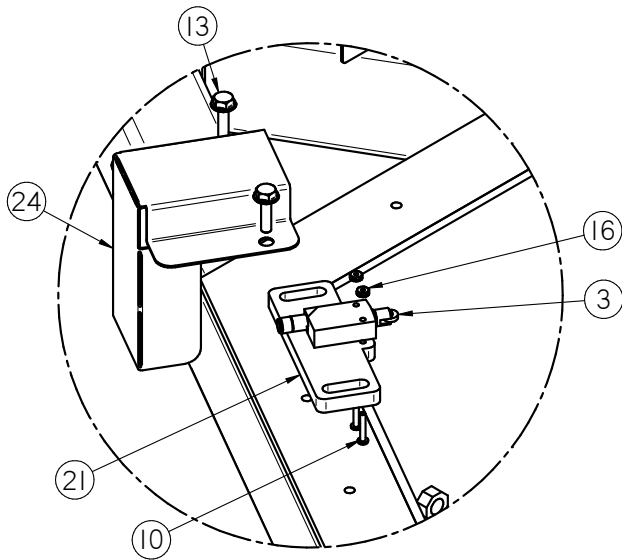

DETAIL A

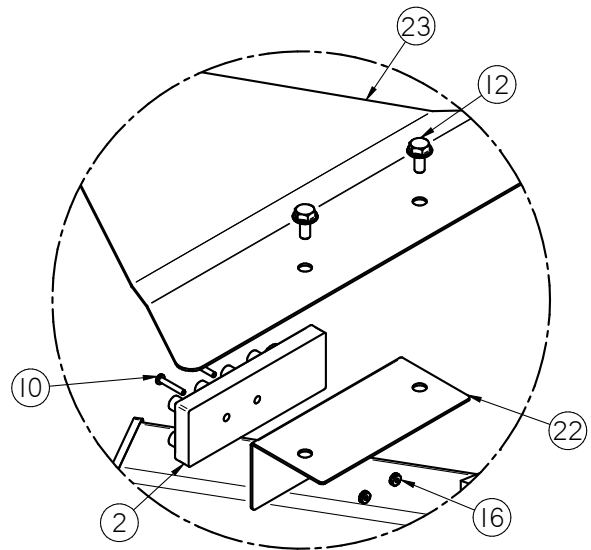

DETAIL B

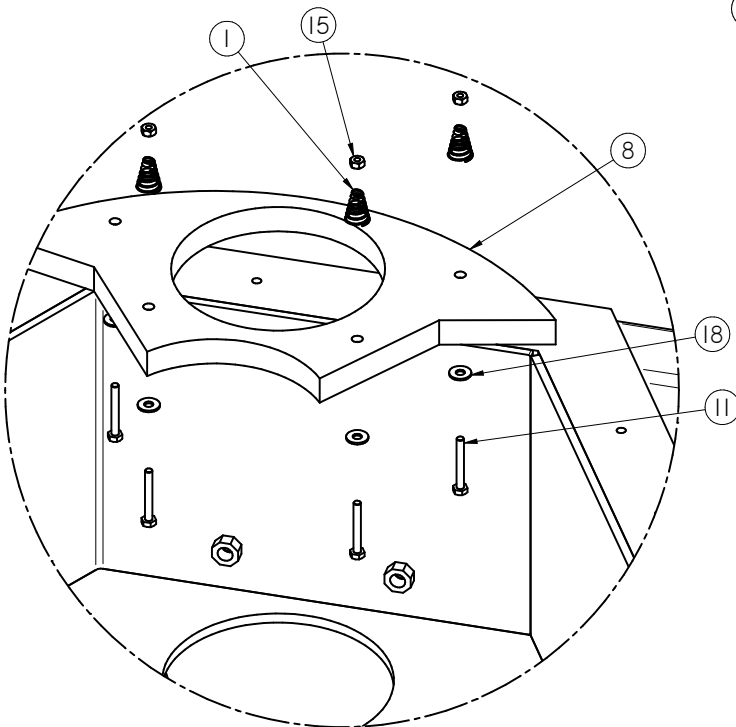

DETAIL C

**DISTRIBUTION DRIVE ASSEMBLY (05-07-0756) VERSION 3**

Item #	Part #	Description	Qty
1	01-04-0094	SPG CNCL COMP .25ID X .045 X 1.25	4
2	03-08-0212	CONN TRCK 8MB12Z-5P3-CS19	1
3	03-10-0125	SW LMT SCHDR XCMD21202C12	1
4	05-03-1076	WDMT SLTR HSG CNTNS FLOW SYSTEM SMW	1
5	05-04-0118	ASSY SLTR BRG HSG CNTNS FLOW SYSTEM	1
6	05-07-0389	WDMT SLTR SPOUT CNTNS FLOW SYS 30U	1
7	05-10-3821	WSHR .25THK X 1.313ID X 3.00OD	1
8	05-10-3823	PLT UHMW 7.0 ID DIST SLIDING SEAL	1
9	05-11-0412	SHAFT DIST DRV 1.75 HEX	1
10	06-01-0094	SCRW PAN HD 8-32 X 1.00 ZP	4
11	06-01-0097	BOLT .250-20 X 2.00 ZP GR5	4
12	06-01-0124	BOLT, FLAG .375-16 UNC ZP GRADE 5; 3/4" LG	2
13	06-01-0189	BOLT, FLAG .375-16 UNC ZP GRADE 5; 1-1/4" LG	2
14	06-01-0224	BOLT CAP .500-13 X 1.00 BTNH	4
15	06-02-0001	NUT FULL .250-20 ZP GR5	4
16	06-02-0034	NUT 8-32 K-LOCK ZP	4
17	06-04-0016	WSHR THRST 1.0 X 1.99 X .088 PCMPST	1
18	06-05-0001	WASHER, FLAT .250	4
19	09-02-0001	ATWK LBL DANGER FINGERS	1
20	09-02-0022	ATWK LBL DANGER AUTO START	2
21	10215E	PLT DIST PROOF SW BRUT CS	1
22	1021F5	BRUT CONN TRCK	1
23	103928	COVER	1
24	103929	SWITCH GUARD	1

**TRI - FLO® TOP ASSEMBLY (05-07-0763) VERSION 3**

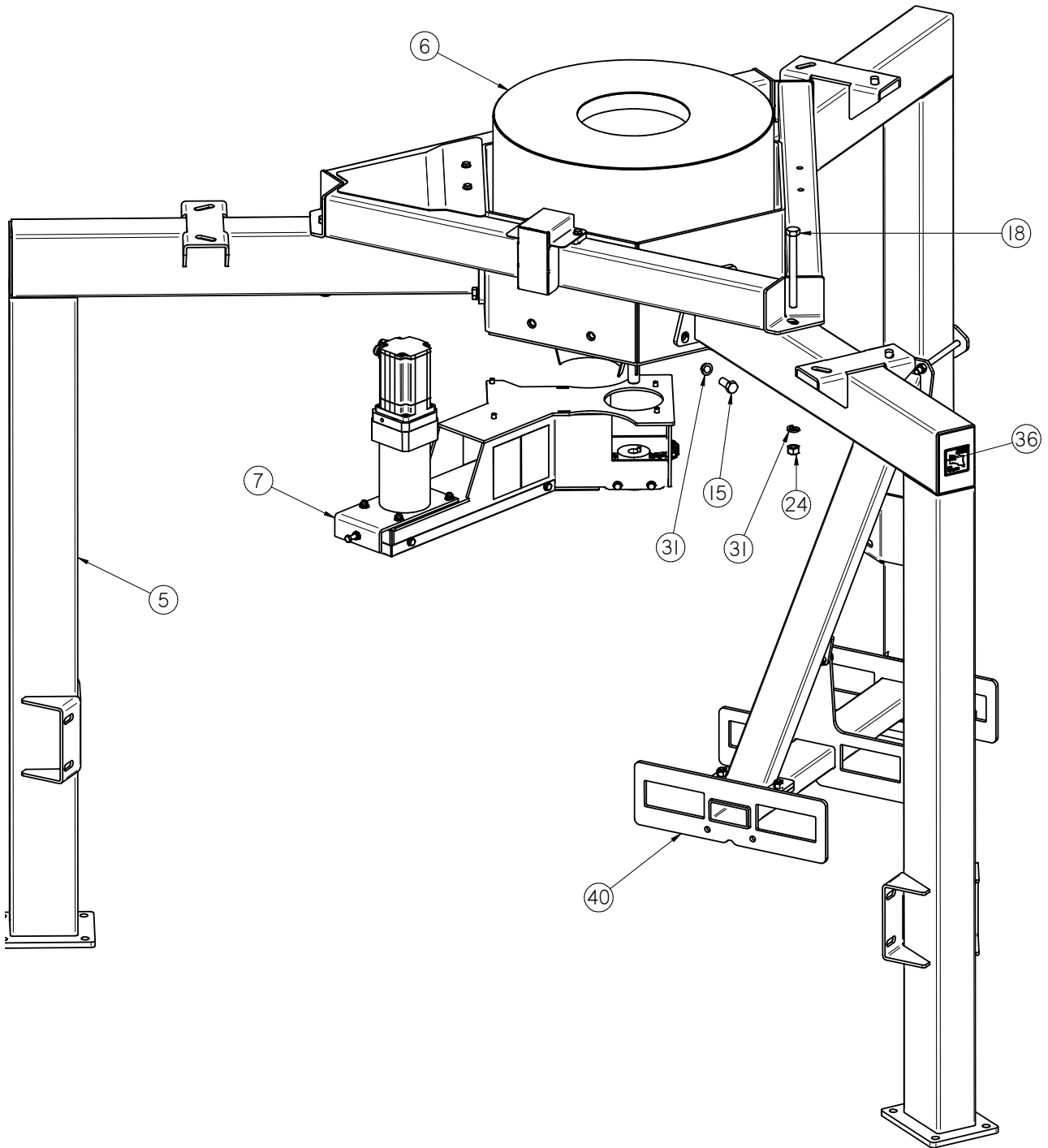

**TRI - FLO® TOP ASSEMBLY (05-07-0763) VERSION 3**

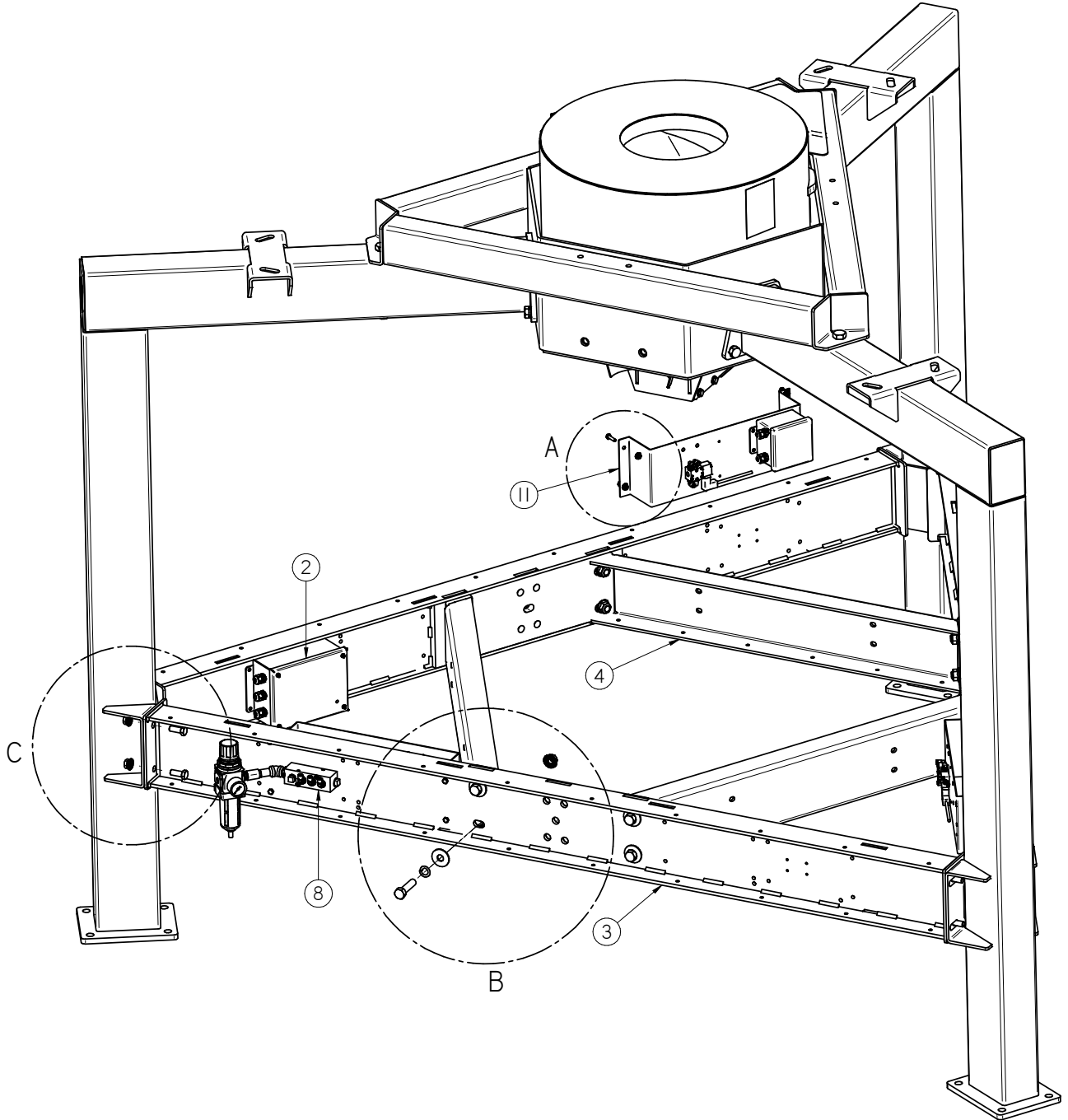

**TRI-FLO® TOP ASSEMBLY (05-07-0763) VERSION 3**

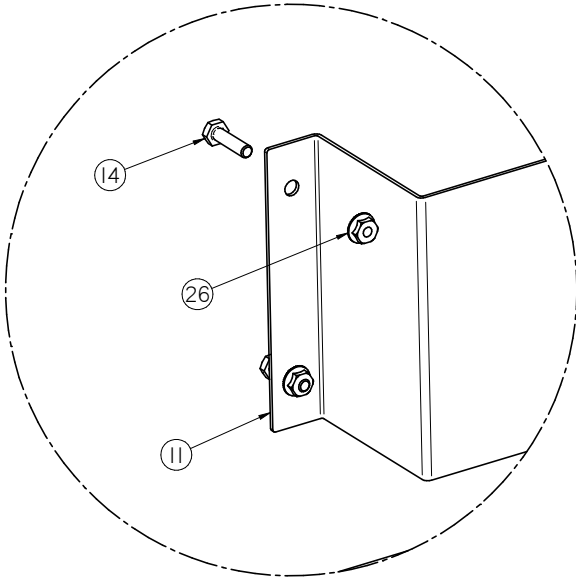

DETAIL A

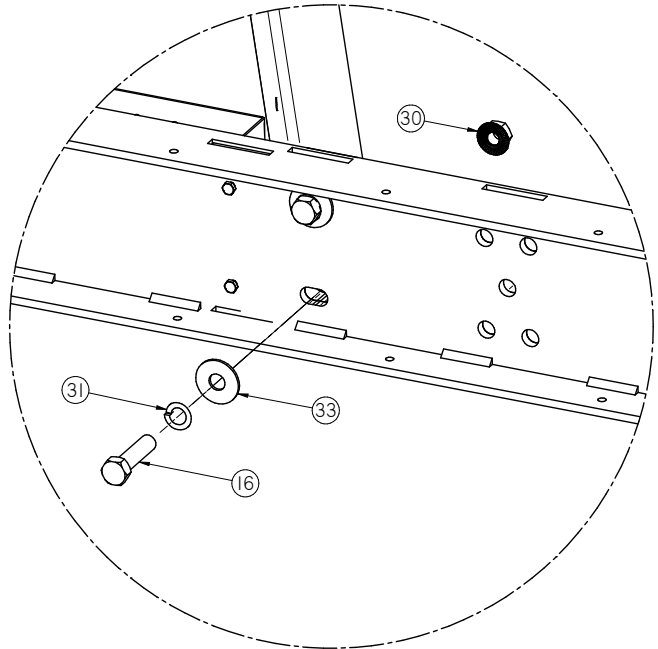

DETAIL B

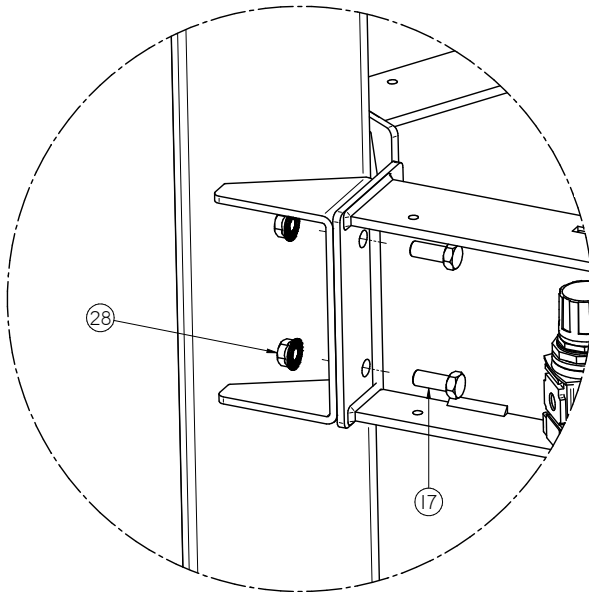

DETAIL C



**TRI - FLO® TOP ASSEMBLY (05-07-0763) VERSION 3**

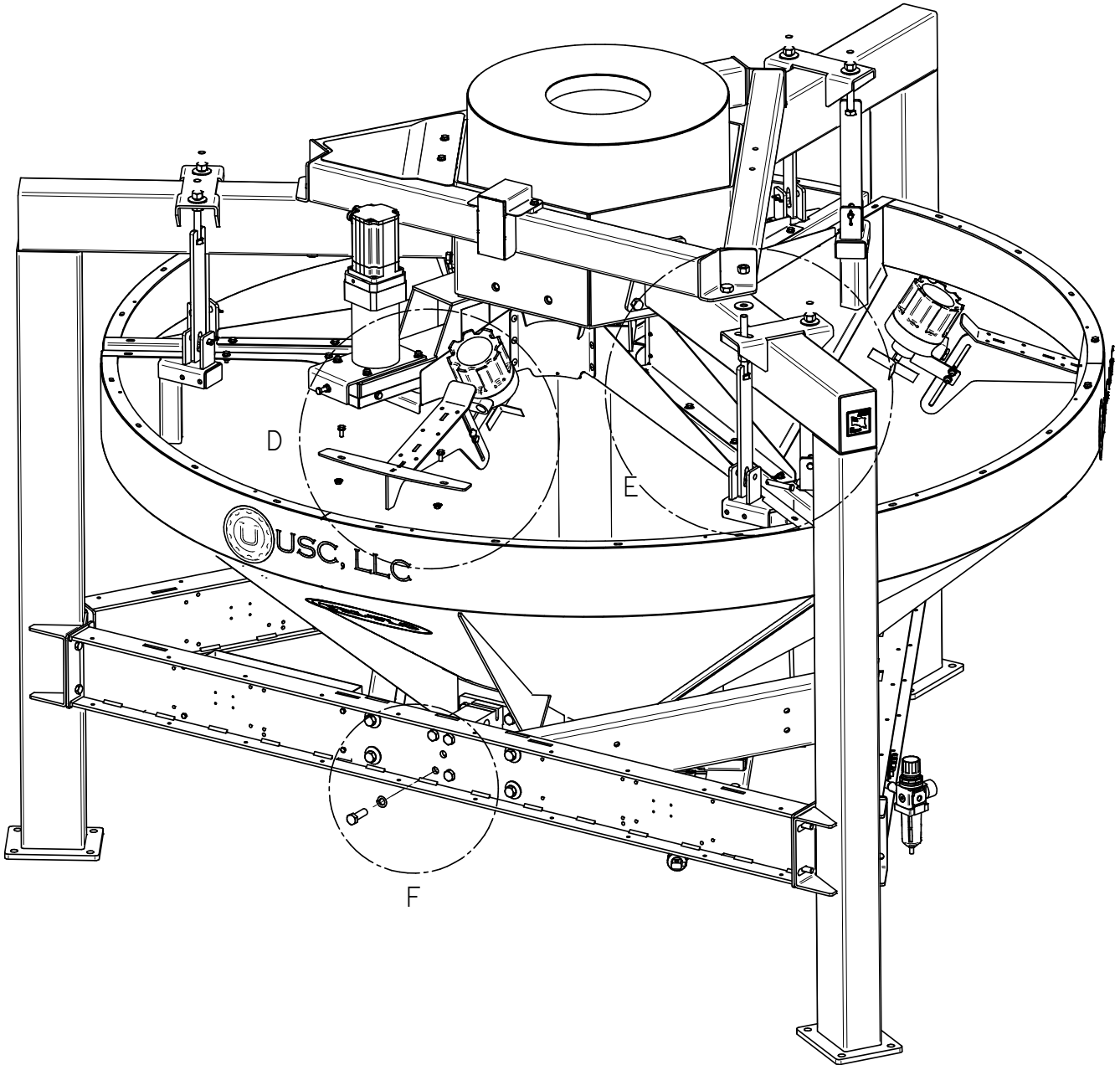

**TRI - FLO® TOP ASSEMBLY (05-07-0763) VERSION 3**

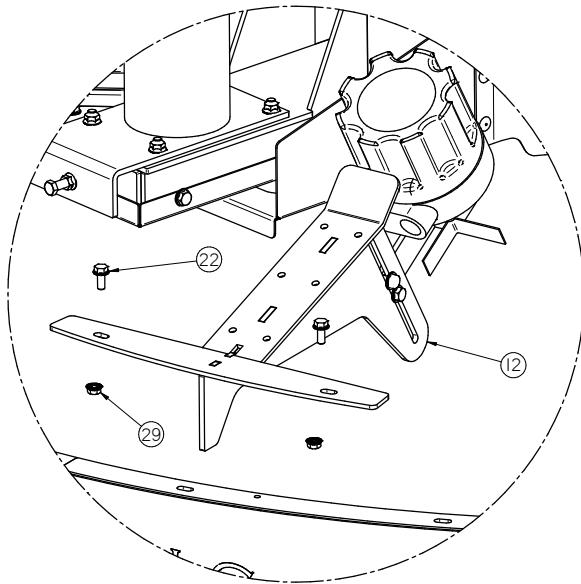

DETAIL D

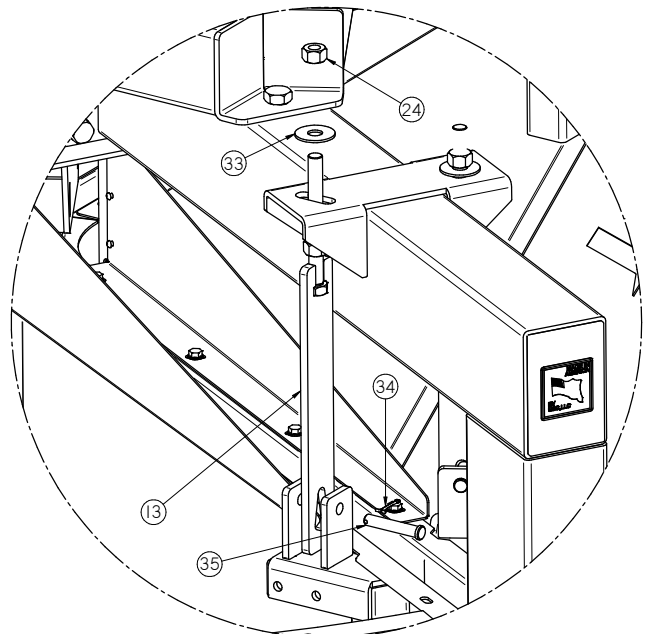

DETAIL E

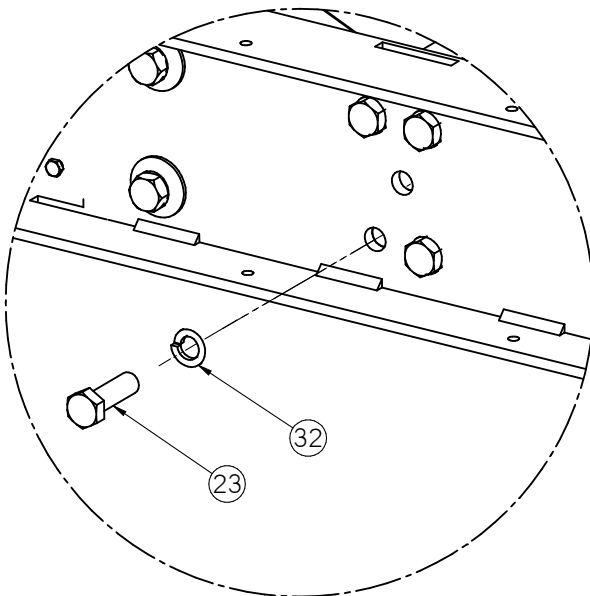

DETAIL F

**TRI - FLO® TOP ASSEMBLY (05-07-0763) VERSION 3**

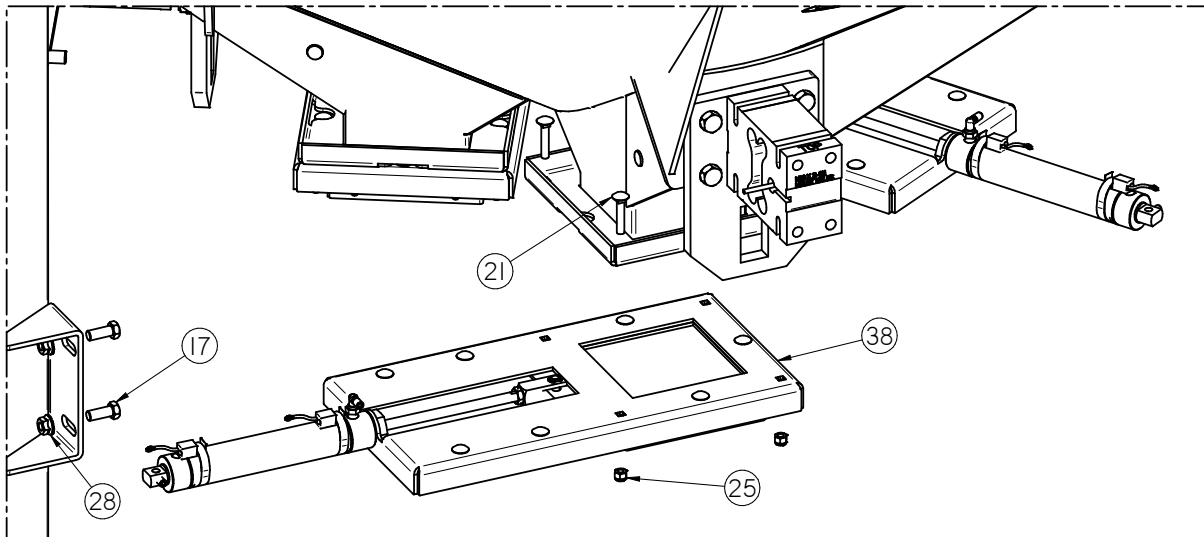
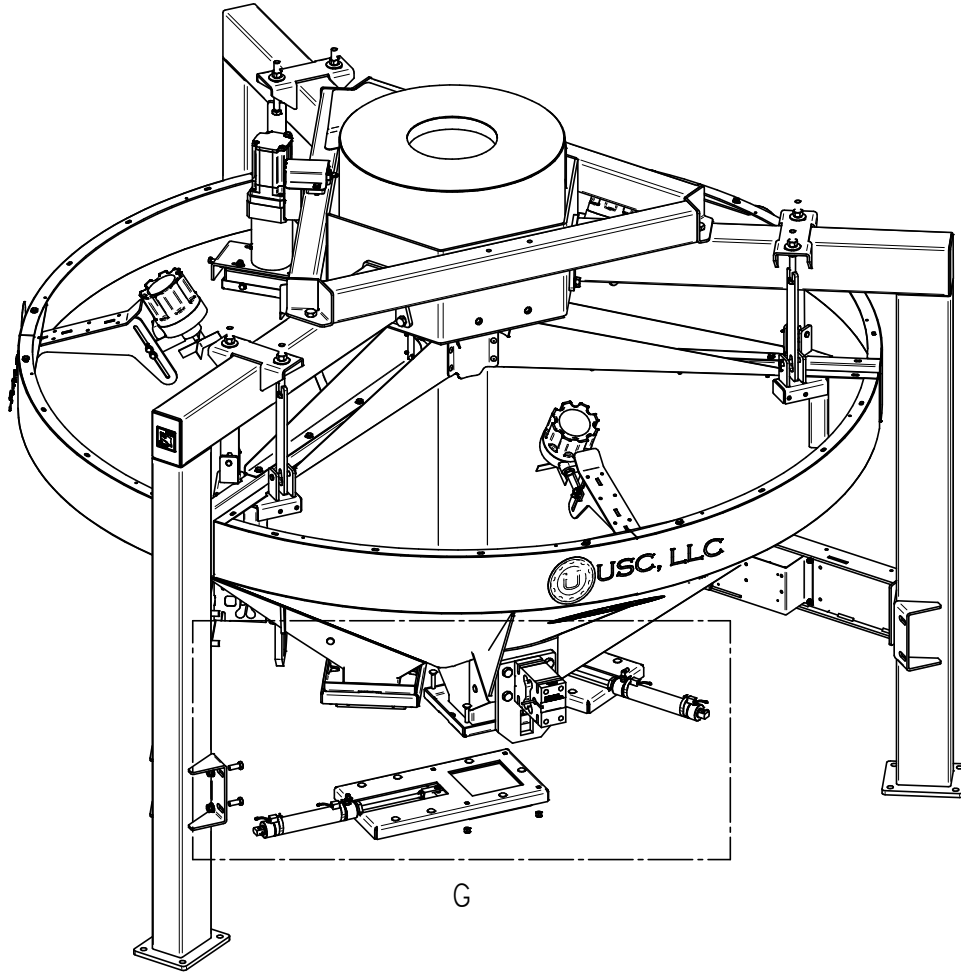

DETAIL G

**TRI - FLO® TOP ASSEMBLY (05-07-0763) VERSION 3**

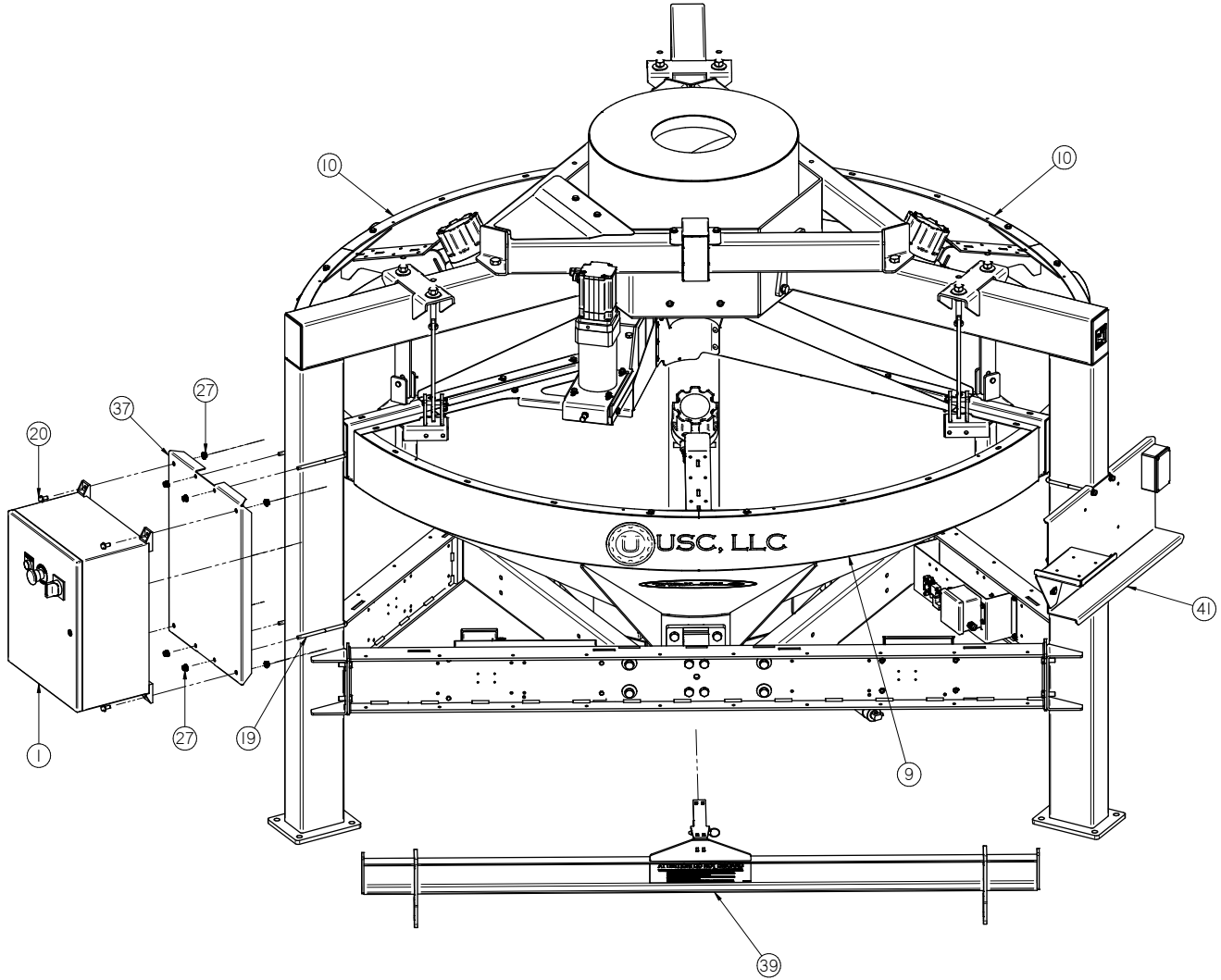

Item #	Part #	Description	Qty
1	03-12-0348	PNL CNTL TRI-FLO SEED WHEEL/SERVO DRIVE	1
2	03-12-0364	PNL LOAD CELL JCT BOX TRI FLO	1
3	05-03-0900	WDMT LEG BRACE CNTNS FLOW SYSTEM	3
4	05-03-1008	WDMT BRACE LDCL PLT	3
5	05-05-0066	WDMT LEG CNTNS FLOW WH SYS OPEN TOP	3
6	05-07-0756	ASSY DIST TRI FLO	1
7	05-07-0757	ASSY SERVO DRV TRI FLO	1

**TRI - FLO® TOP ASSEMBLY (05-07-0763) VERSION 3**

Item #	Part #	Description	Qty
8	05-07-0758	ASSY AIR MNFD TRI FLO	1
9	05-07-0759	ASSY HOPP 1 TRI FLO	1
10	05-07-0760	ASSY HOPP 2-3 TRI FLO	2
11	05-07-0761	ASSY SLD GATE VALE TRI FLO	3
12	05-07-0762	ASSY HIGH LVL INDI TRI FLO	3
13	05-09-0045	WDMT HOPP SUPP STRAP TRI-FLO	6
14	06-01-0007	BOLT, .250-20 X 1 UNC ZP GRADE 5	12
15	06-01-0031	BOLT, .625-11 G5 ZP 1.50	6
16	06-01-0075	BOLT, .625 X 11 X 2.50" UNC ZP GRADE 5	12
17	06-01-0080	BOLT .500-13 X 1.25 ZP GR5	12
18	06-01-0096	BOLT .625-11 X 7.00 ZP GR5	3
19	06-01-0113	BOLT U .375-16 X 4.00 X 6.625 ZP	2
20	06-01-0124	BOLT FLAG .375-16 X .750 ZP GR5	4
21	06-01-0136	BOLT CRG .375-16 X 2.00 ZP GR5	12
22	06-01-0138	BOLT, FLAG .3125-18 UNC ZP GRADE 5; 3/4" LG	6
23	06-01-0230	BOLT M16-2.00 X 50MM FTH	12
24	06-02-0005	NUT, .625-11 UNC ZP GRADE 5	15
25	06-03-0003	NUT NYL LOCK .375-16 ZP GR5	12
26	06-03-0013	NUT,LOCK, FLAG .250-20 ZP SERRATED	12
27	06-03-0014	NUT LOCK FLAG .375-16 ZP GR5	8
28	06-03-0015	NUT LOCK FLAG .500-13 ZP GR5	12
29	06-03-0019	NUT LOCK FLAG .3125-18 ZP GR5	6
30	06-03-0029	NUT WHIZ LOCK FLAG .625-11 GR5	12
31	06-04-0005	WASHER, .625 LOCK ZP	21
32	06-04-0018	WSHR LOCK SPLT M16 ZP	12
33	06-05-0006	WASHER, .625 FLAT ZP	18
34	06-09-0018	PIN CTTR .125 X 1.50 SS	6
35	06-09-0058	PIN CLVS .500 X 2.75 PLN	6
36	09-01-0003	ATWK LBL MADE IN USA YEL 2.50X2.50	3
37	102B71	BRUT TRI-FLO PNL	1
38	12-04-0023	SLIDE GATE 6.00 SQ TRI-FLO SIMPLE	3
39	13-05-0263	KIT WEIGHT BAR TRI-FLOW	1
40	13-05-0268	KIT FORK PCKT ASSY TRI-FL	1
41	13-10-0019	KIT BOLT INDI PNTR ESTP	1

**SLIDE GATE ASSEMBLY (12-04-0045) VERSION 4**

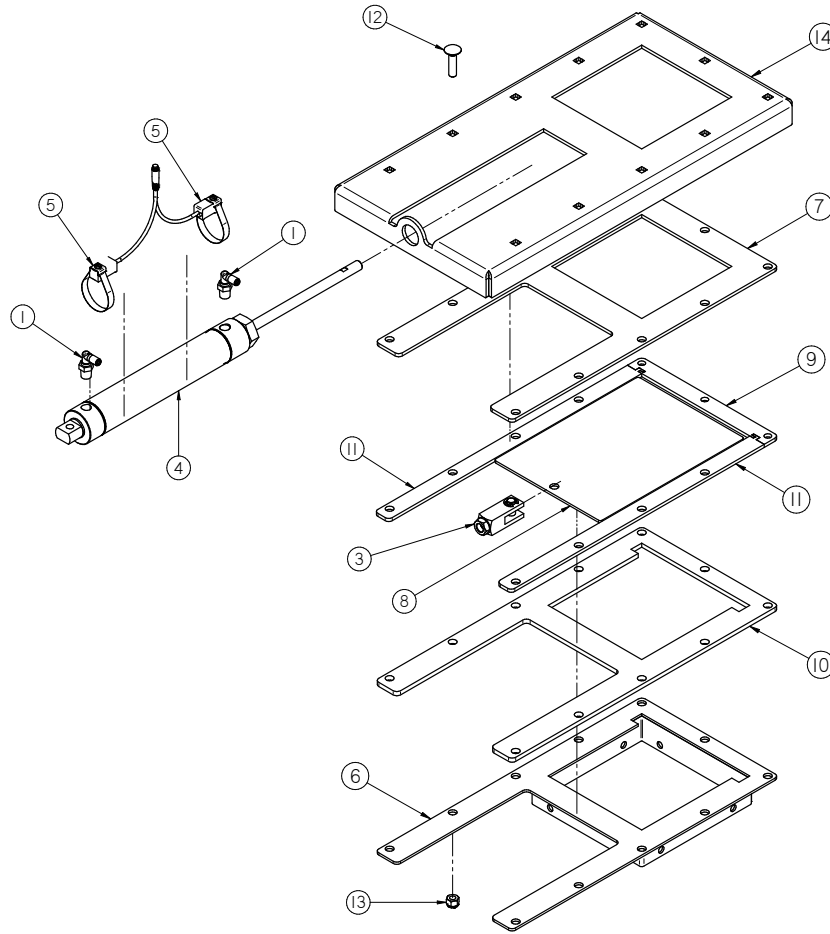

Item #	Part #	Description	Qty
1	02-16-0044	FTTG PUSH 90 DEG .250OD X .250 NPT	2
2	03-08-0380	CONN TRCK YP2-RS 4.4T-8/2PKG3M-0.3	1
3	03-17-0041	CLEVIS ASSY BIMBA D-8313-A	1
4	03-17-0093	BIMBA AIR CYL 1.75 X 7 M-247-DP	1
5	03-17-0148	SW MAG REED MRS-.087-BLQ-17	2
6	05-07-0370	WDMT DSCHG 6.00IN SQ SLGT	1
7	05-10-3751	PLT SLGTUHMW TOP 6.00IN SQ	1
8	05-10-3752	PLT SLGT 6.00IN SQ	1
9	05-10-3753	STOP UHMW SLGT 6.00IN SQ	1
10	05-10-3754	PLT UHMW LOWER SLGT 6.00IN SQ	1
11	05-10-3755	GUIDE UHMW SIDE SLGT 6.00IN SQ	2
12	06-01-0128	BOLT CRG .375-16 X 1.50 ZP GR5	7
13	06-03-0003	NUT NYL LOCK .375-16 ZP GR5	7
14	102ACC	PLT SLGT BODY 6.00IN SQ	1

**DISTRIBUTION DRIVE ASSEMBLY (05-07-0984) VERSION 4**

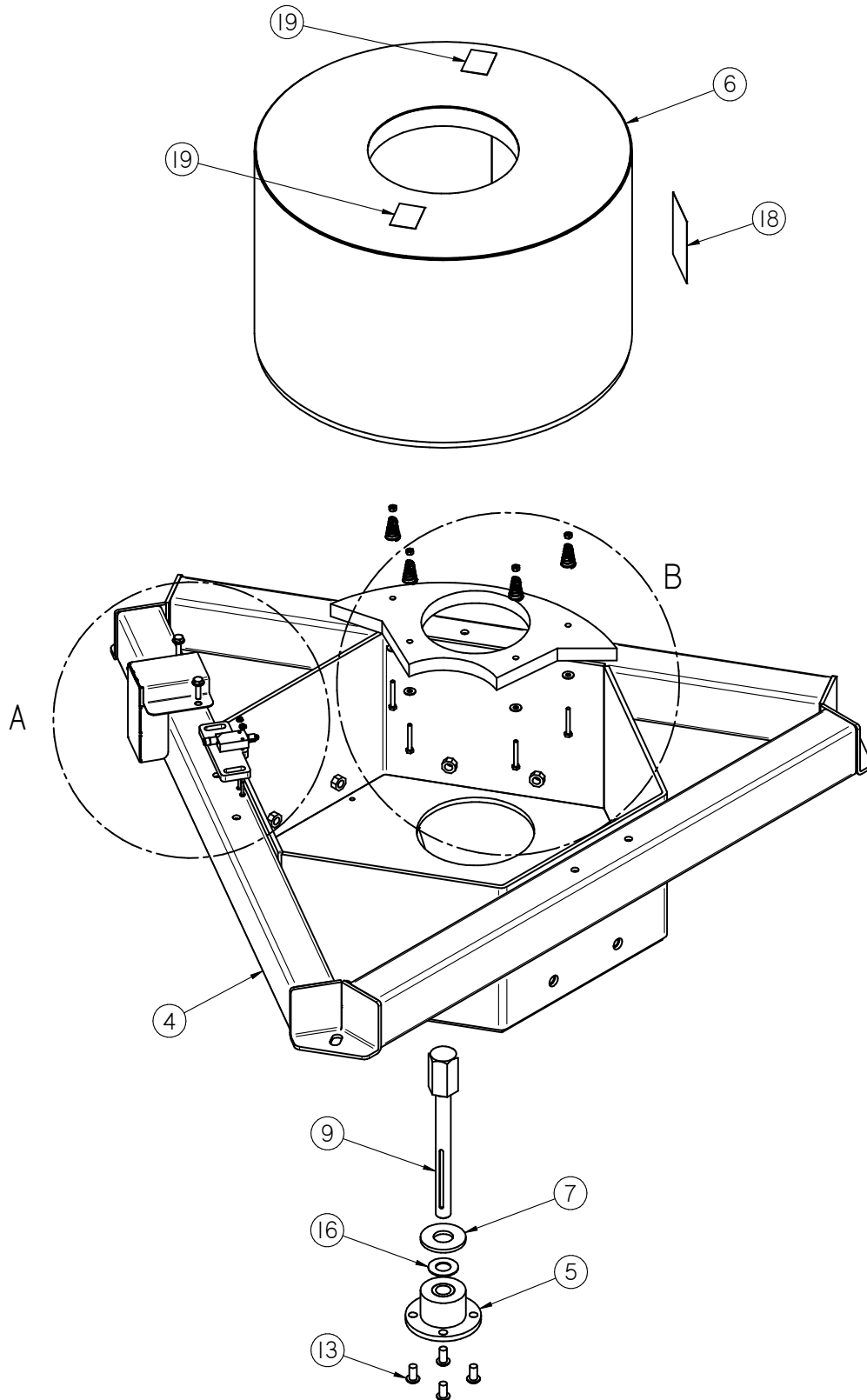



**DISTRIBUTION DRIVE ASSEMBLY (05-07-0984) VERSION 4**

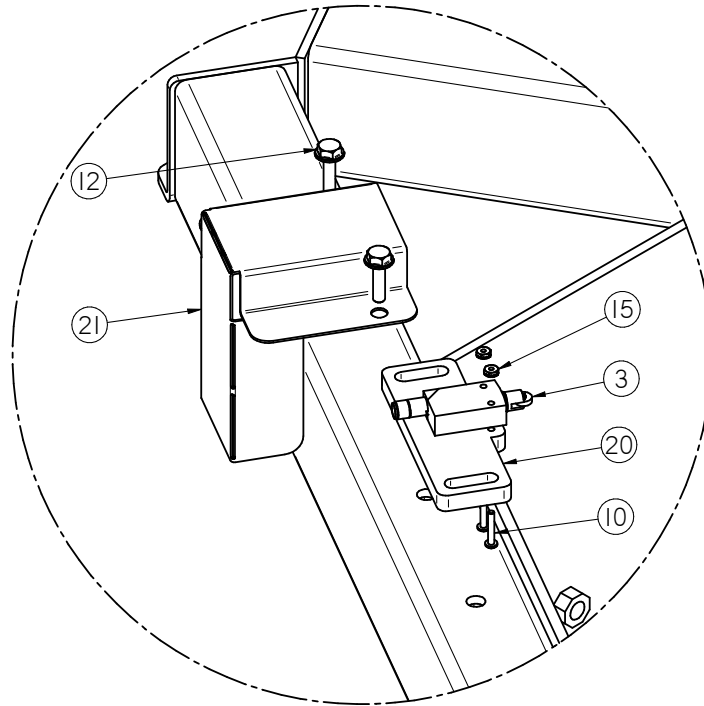

DETAIL A

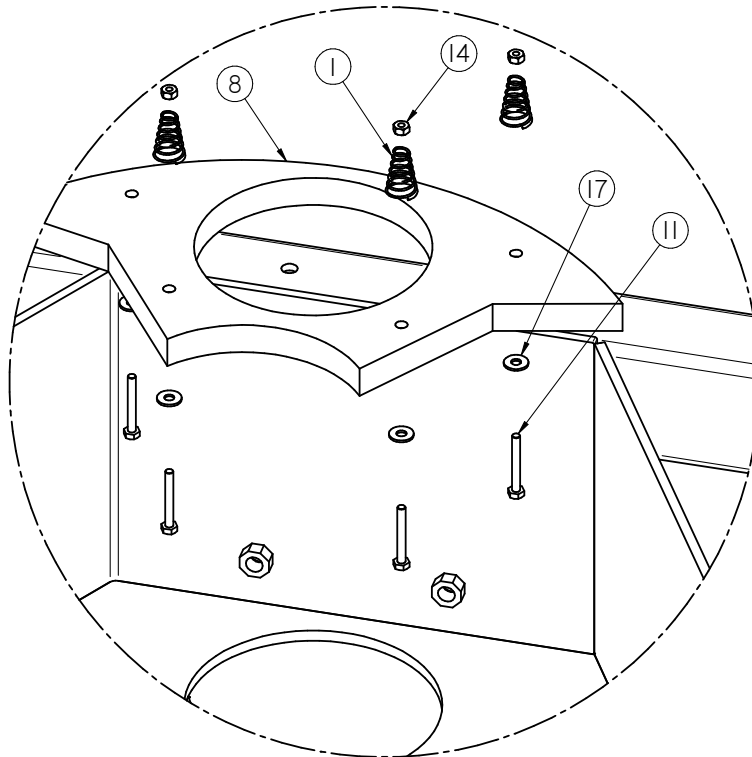

DETAIL B

**DISTRIBUTION DRIVE ASSEMBLY (05-07-0984) VERSION 4**

Item #	Part #	Description	Qty
1	01-04-0094	SPG CNCL COMP .26ID X .055 X 1.50 LG	4
2	03-08-0316	CONN TRCK RK4.4T-8-RS4.4T/S760/S771	1
3	03-10-0125	SW LMT SCHDR XCMD21202C12	1
4	05-03-1076	WDMT SLTR HSG CNTNS FLOW SYSTEM SMW	1
5	05-04-0118	ASSY SLTR BRG HSG CNTNS FLOW SYSTEM	1
6	05-07-0389	WDMT SLTR SPOUT CNTNS FLOW SYS 30U	1
7	05-10-3821	WSHR .25THK X 1.313ID X 3.00OD	1
8	05-10-3823	PLT UHMW 7.0 ID DIST SLIDING SEAL	1
9	05-11-0412	SHAFT DIST DRV 1.75 HEX	1
10	06-01-0094	SCRW PAN HD 8-32 X 1.00 ZP	2
11	06-01-0097	BOLT .250-20 X 2.00 ZP GR5	4
12	06-01-0189	BOLT FLAG .375-16 X 1.250 ZP GR5	2
13	06-01-0224	BOLT CAP .500-13 X 1.00 BTNH	4
14	06-02-0001	NUT FULL .250-20 ZP GR5	4
15	06-02-0034	NUT 8-32 K-LOCK ZP	2
16	06-04-0016	WSHR THRST 1.0 X 1.99 X .088 PCMPST	1
17	06-05-0001	WASHER, FLAT .250	4
18	09-02-0001	ATWK LBL DANGER FINGERS	1
19	09-02-0022	ATWK LBL DANGER AUTO START	2
20	10215E	PLT DIST PROOF SW BRUT CS	1
21	103929	SWITCH GUARD	1

**TRI - FLO® TOP ASSEMBLY (05-07-0967) VERSION 4**

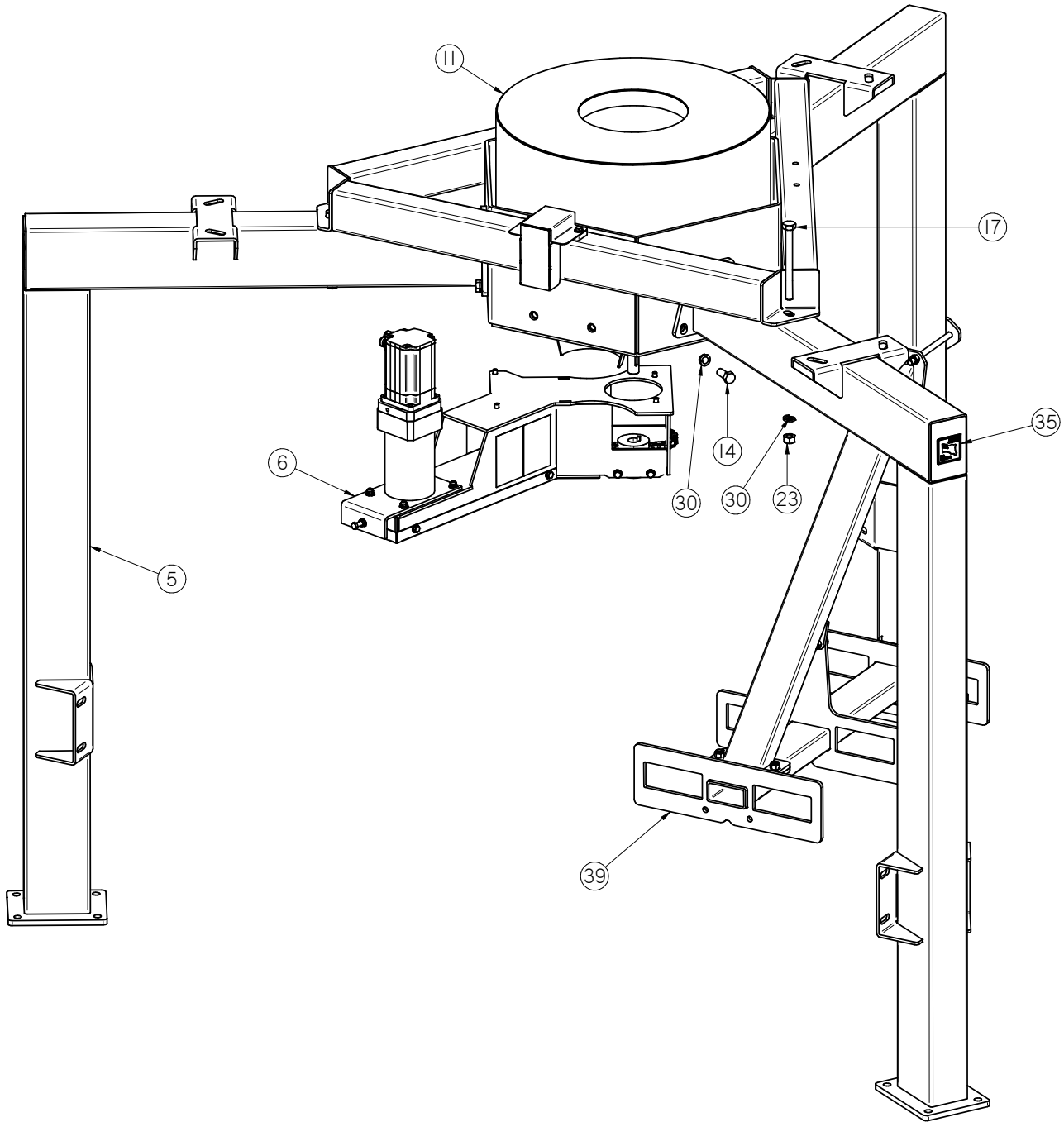

**TRI - FLO® TOP ASSEMBLY (05-07-0967) VERSION 4**

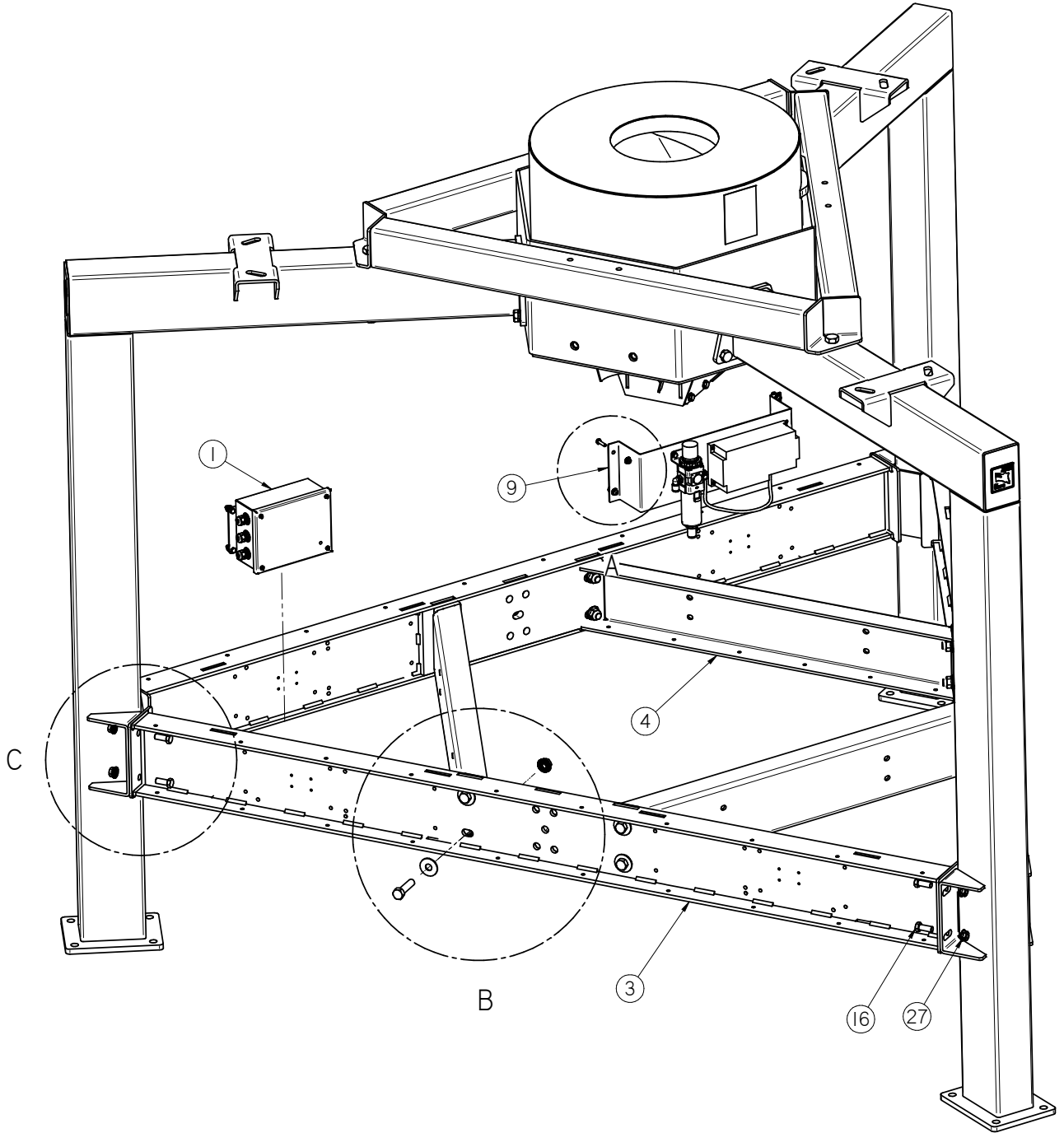

**TRI - FLO® TOP ASSEMBLY (05-07-0967) VERSION 4**

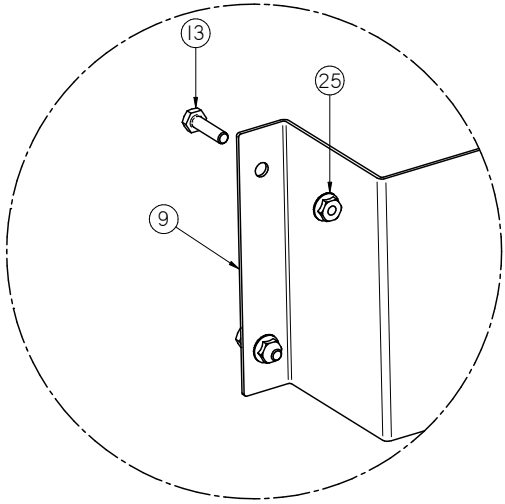

DETAIL A

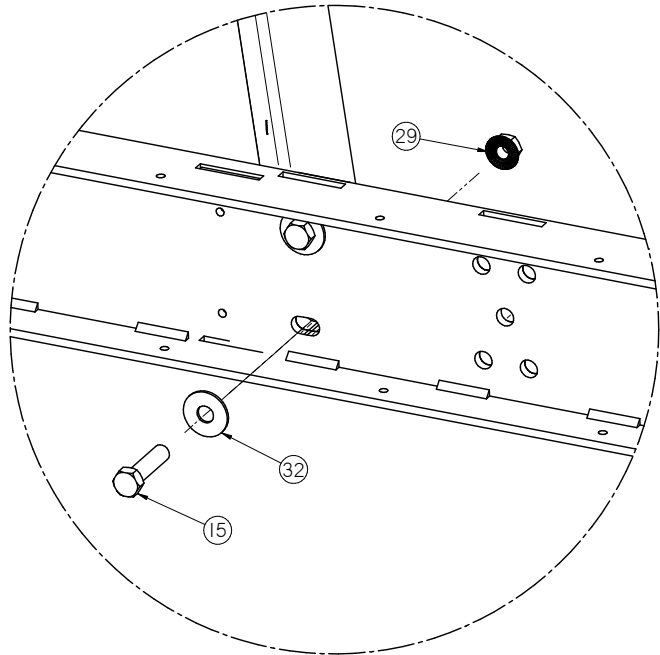

DETAIL B

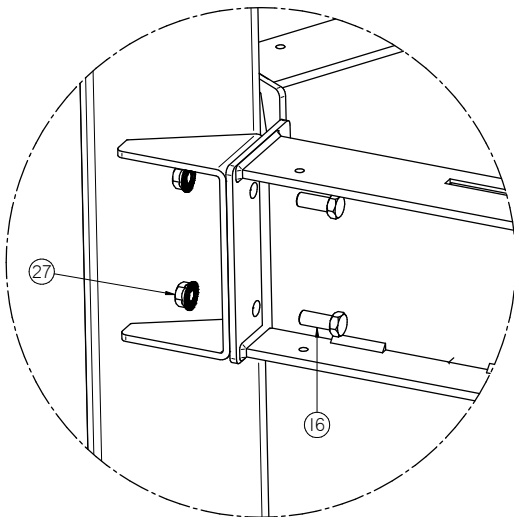

DETAIL C

**TRI - FLO® TOP ASSEMBLY (05-07-0967) VERSION 4**

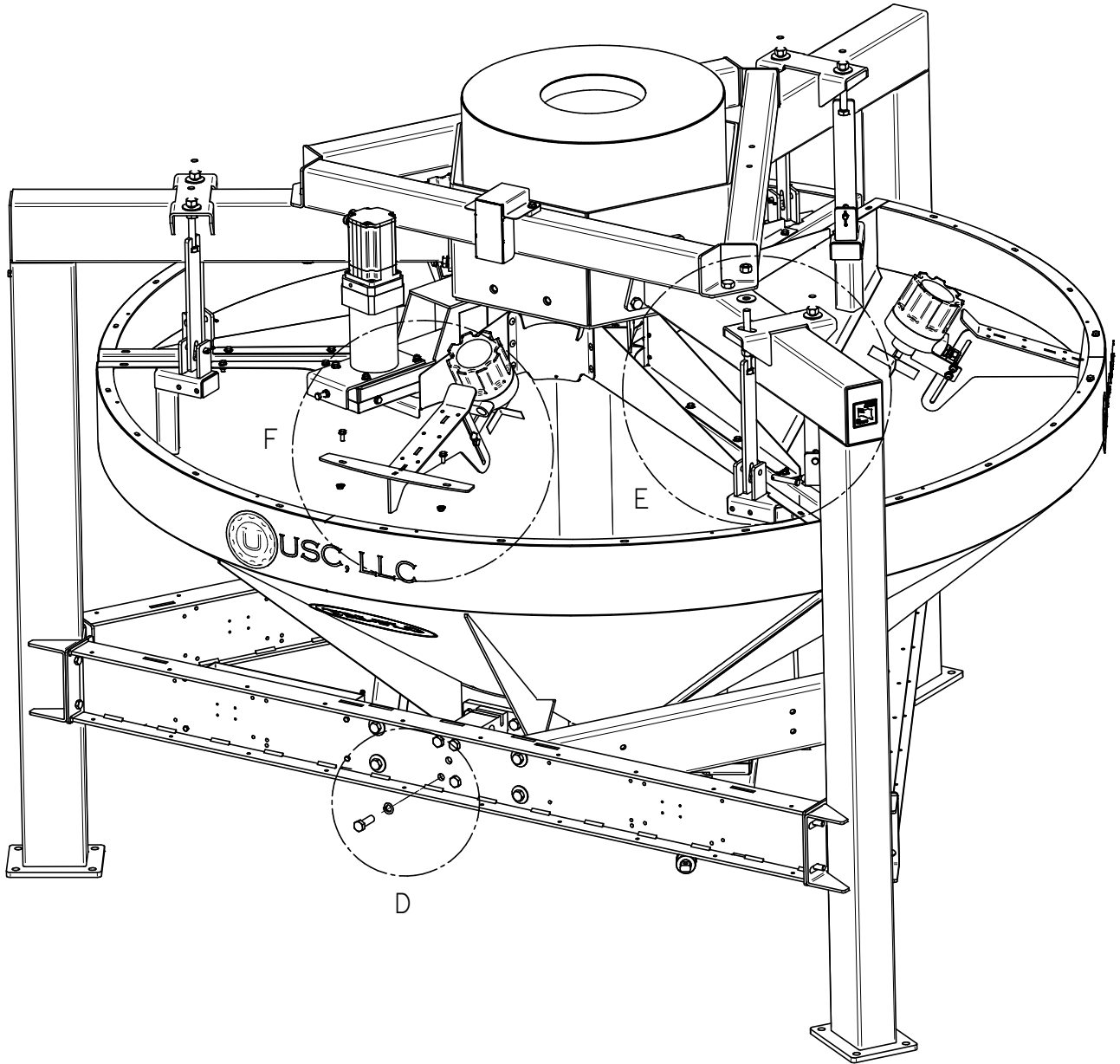

**TRI - FLO® TOP ASSEMBLY (05-07-0967) VERSION 4**

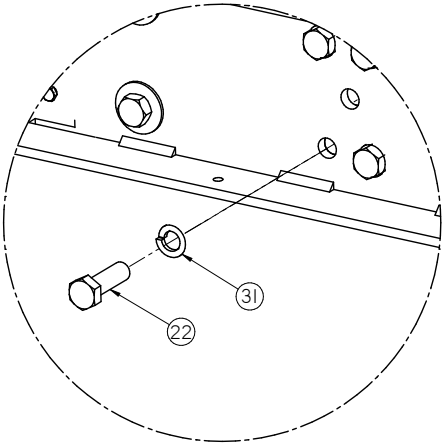

DETAIL D

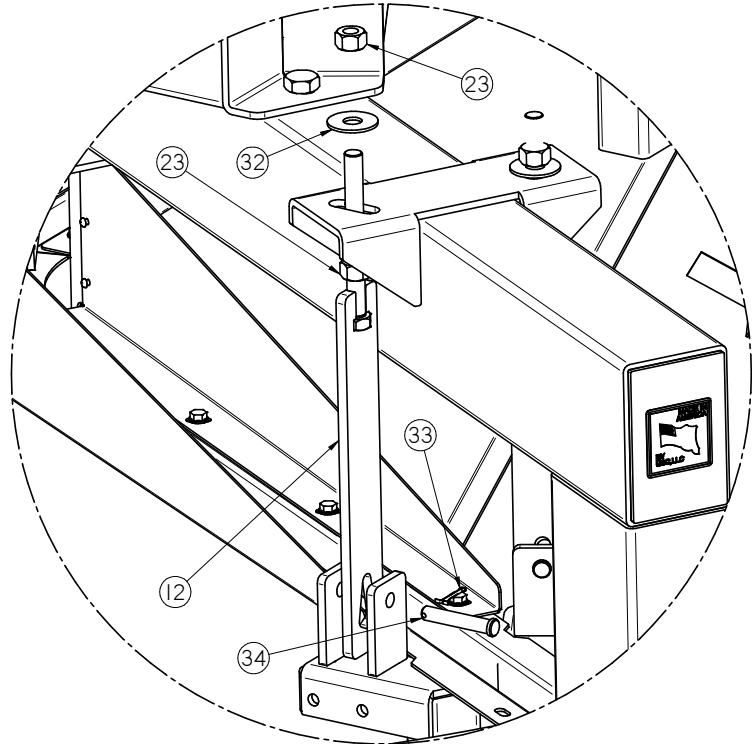

DETAIL E

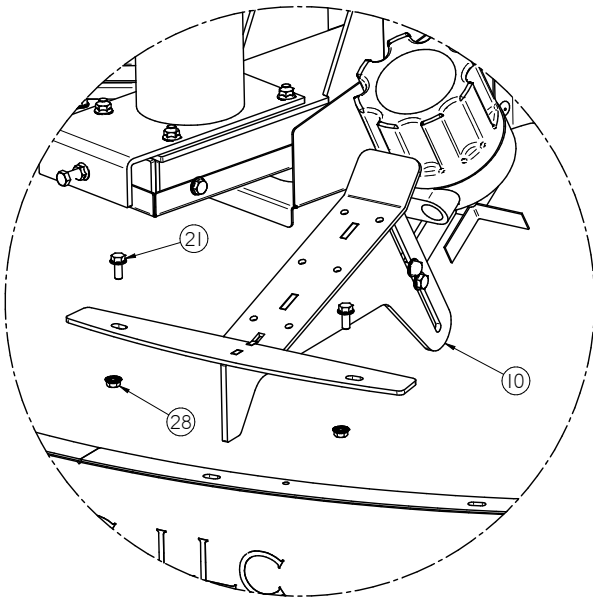

DETAIL F



**TRI - FLO® TOP ASSEMBLY (05-07-0967) VERSION 4**

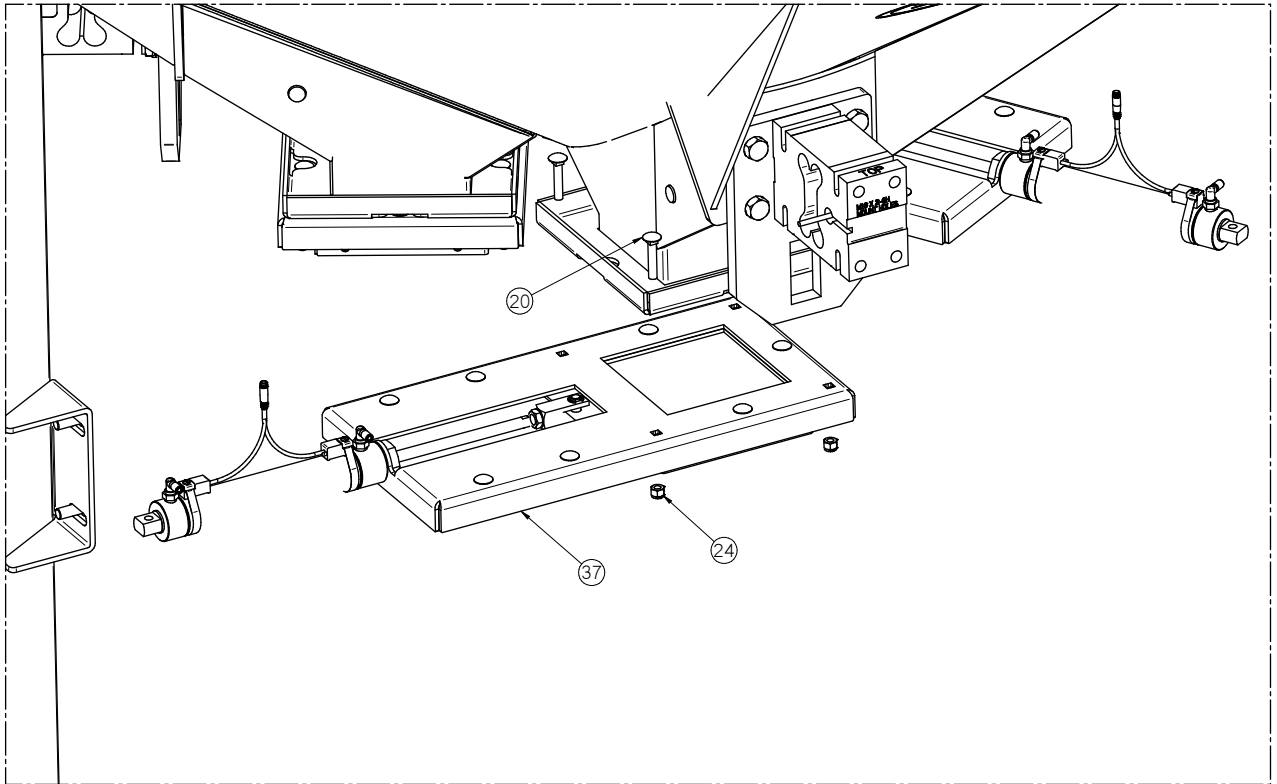

**TRI - FLO® TOP ASSEMBLY (05-07-0967) VERSION 4**

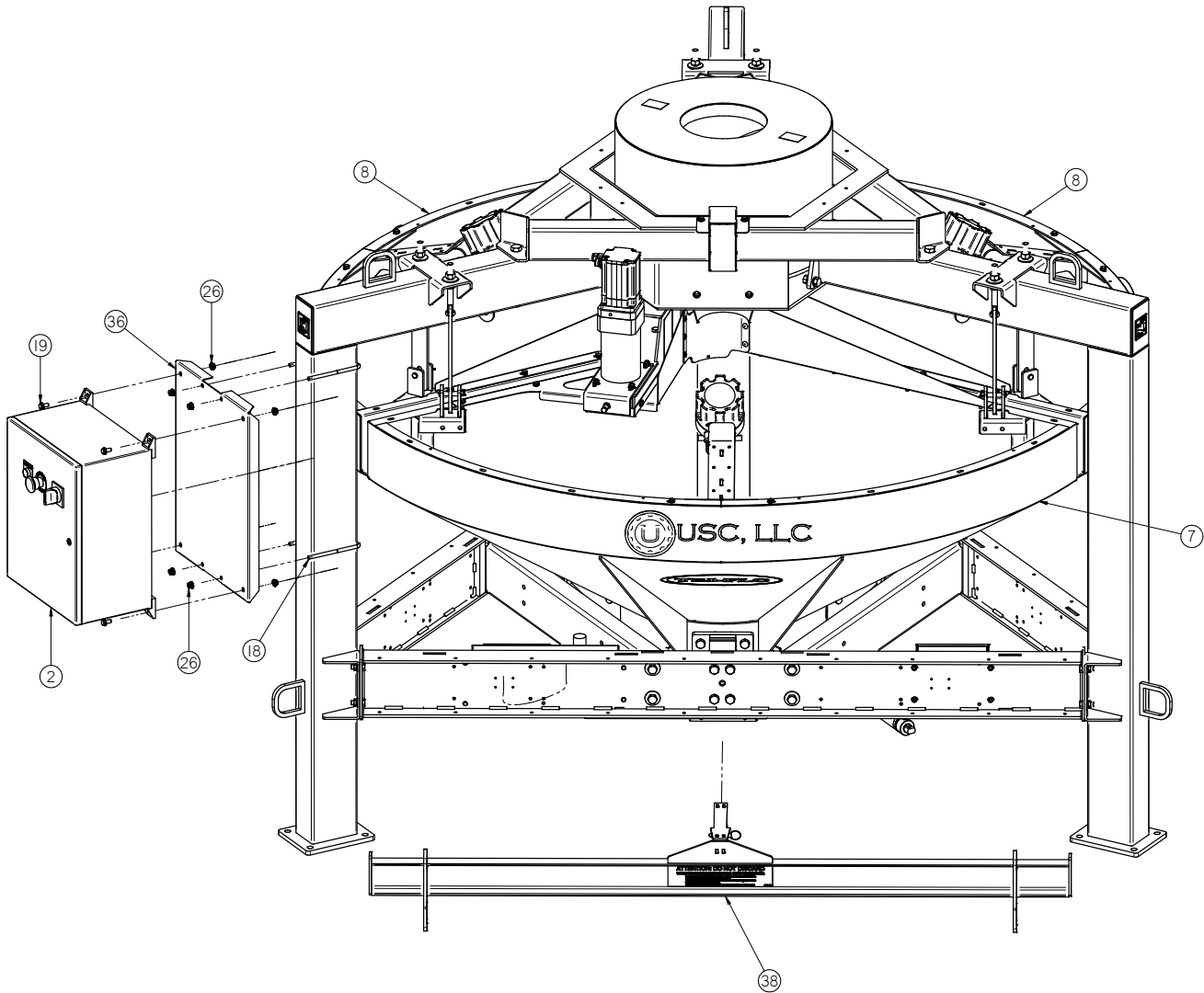

Item #	Part #	Description	Qty
1	03-12-0364	PNL LOAD CELL JCT BOX TRI FLO	1
2	03-12-0552	PNL CNTL V4 TRI-FLO SERVO DRV PNL	1
3	05-03-0900	WDMT LEG BRACE CNTNS FLOW SYSTEM	3
4	05-03-1008	WDMT BRACE LDCL PLT	3
5	05-05-0066	WDMT LEG CNTNS FLOW WH SYS OPEN TOP	3
6	05-07-0757	ASSY SERVO DRV TRI FLO	1
7	05-07-0759	ASSY HOPP 1 TRI FLO	1

**TRI - FLO® TOP ASSEMBLY (05-07-0967) VERSION 4**

Item #	Part #	Description	Qty
8	05-07-0760	ASSY HOPP 2-3 TRI FLO	2
9	05-07-0969	ASSY SMC VLV & REGL TRI FLO V4	1
10	05-07-0974	ASSY HIGH LVL INDI TRI FLO V4	3
11	05-07-0984	ASSY DIST TRI FLO V4	1
12	05-09-0045	WDMT HOPP SUPP STRAP TRI-FLO	6
13	06-01-0007	BOLT, .250-20 X 1 UNC ZP GRADE 5	4
14	06-01-0031	BOLT,.625-11 G5 ZP 1.50	6
15	06-01-0075	BOLT, .625 X 11 X 2.50" UNC ZP GRADE 5	12
16	06-01-0080	BOLT .500-13 X 1.25 ZP GR5	12
17	06-01-0096	BOLT .625-11 X 7.00 ZP GR5	3
18	06-01-0113	BOLT U .375-16 X 4.00 X 6.625 ZP	2
19	06-01-0124	BOLT FLAG .375-16 X .750 ZP GR5	4
20	06-01-0136	BOLT CRG .375-16 X 2.00 ZP GR5	12
21	06-01-0138	BOLT, FLAG .3125-18 UNC ZP GRADE 5; 3/4" LG	6
22	06-01-0230	BOLT M16-2.00 X 50MM FTH	12
23	06-02-0005	NUT, .625-11 UNC ZP GRADE 5	15
24	06-03-0003	NUT NYL LOCK .375-16 ZP GR5	12
25	06-03-0013	NUT,LOCK, FLAG .250-20 ZP SERRATED	4
26	06-03-0014	NUT LOCK FLAG .375-16 ZP GR5	8
27	06-03-0015	NUT LOCK FLAG .500-13 ZP GR5	12
28	06-03-0019	NUT LOCK FLAG .3125-18 ZP GR5	6
29	06-03-0029	NUT WHIZ LOCK FLAG .625-11 GR5	12
30	06-04-0005	WASHER, .625 LOCK ZP	9
31	06-04-0018	WSHR LOCK SPLT M16 ZP	12
32	06-05-0006	WASHER, .625 FLAT ZP	18
33	06-09-0018	PIN CTTR .125 X 1.50 SS	6
34	06-09-0058	PIN CLVS .500 X 2.75 PLN	6
35	09-01-0003	ATWK LBL MADE IN USA YEL 2.50X2.50	3
36	102B71	BRUT TRI-FLO PNL	1
37	12-04-0045	SLIDE GATE 6.00 SQ TRI-FLO V4	3
38	13-05-0263	KIT WEIGHT BAR TRI-FLOW	1
39	13-05-0268	KIT FORK PCKT ASSY TRI-FL	1

**WEIGHT CALIBRATION BAR ASSEMBLY (13-05-0598) VERSION 4HC**

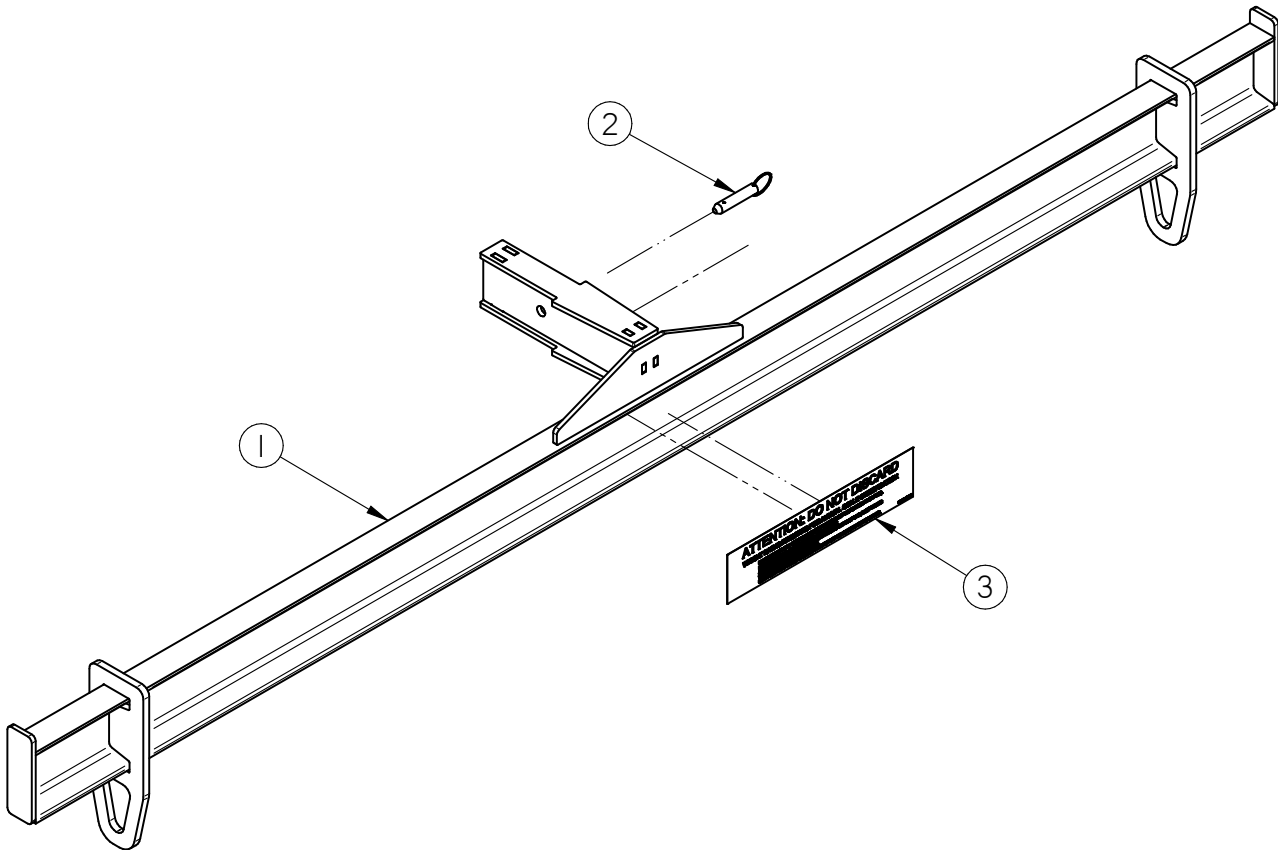

Item #	Part #	Description	Qty
1	05-09-0054	WDMT WEIGHT BAR TRI-FLOW	1
2	06-09-0070	PIN SPGLD QCK REL RING GRIP 0.5DIA	1
3	09-02-0017	LBL ATWRK ATT WGHT BAR TRI-FL	1

**SLIDE GATE ASSEMBLY (12-04-0042) VERSION 4HC**

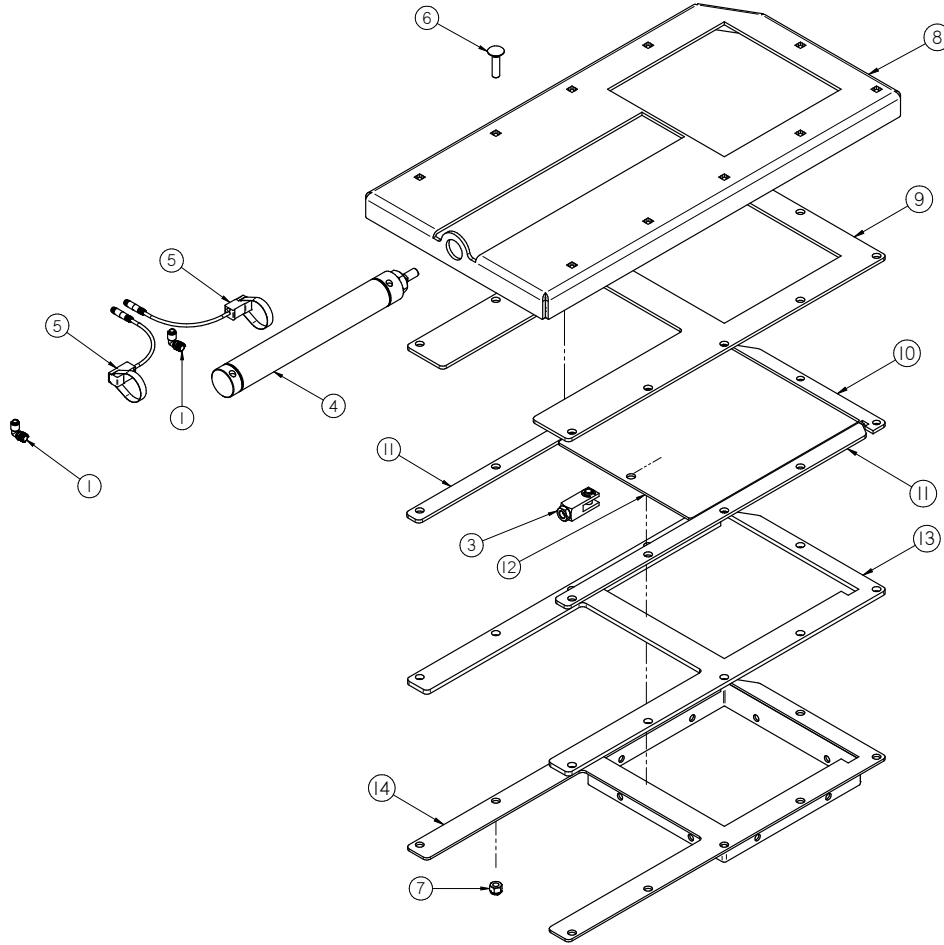

Item #	Part #	Description	Qty
1	02-16-0046	FTTG PUSH 90 DEG .250 OD X .125 NPT	2
2	03-08-0380	CONN TRCK YP2-RS 4.4T-8/2PKG3M-0.3	1
3	03-17-0046	CLEVIS ASSY BIMBA D-8311-A	1
4	03-17-0067	CYL AIR 9"STROKE 1.5 IN BORE DBL	1
5	03-17-0149	SW MAG REED MRS-.087-BLQ-17	2
6	06-01-0128	BOLT CRG .375-16 X 1.50 ZP GR5	7
7	06-03-0003	NUT NYL LOCK .375-16 ZP GR5	7
8	105256	PLT SLGT BODY 8.00IN SQ	1
9	105257	PLT SLGTUHMW TOP 8.00IN SQ	1
10	105258	STOP UHMW SLGT 8.00IN SQ	1
11	105259	GUIDE UHMW SIDE SLGT 8.00IN SQ	2
12	10525b	PLT SLGT 8.00IN SQ	1
13	10525C	PLT UHMW LOWER SLGT 8.00IN SQ	1
14	10525D	WDMT DSCHG 8.00IN SQ SLGT	1

**SERVO DRIVE ASSEMBLY (05-07-0917) VERSION 4HC**

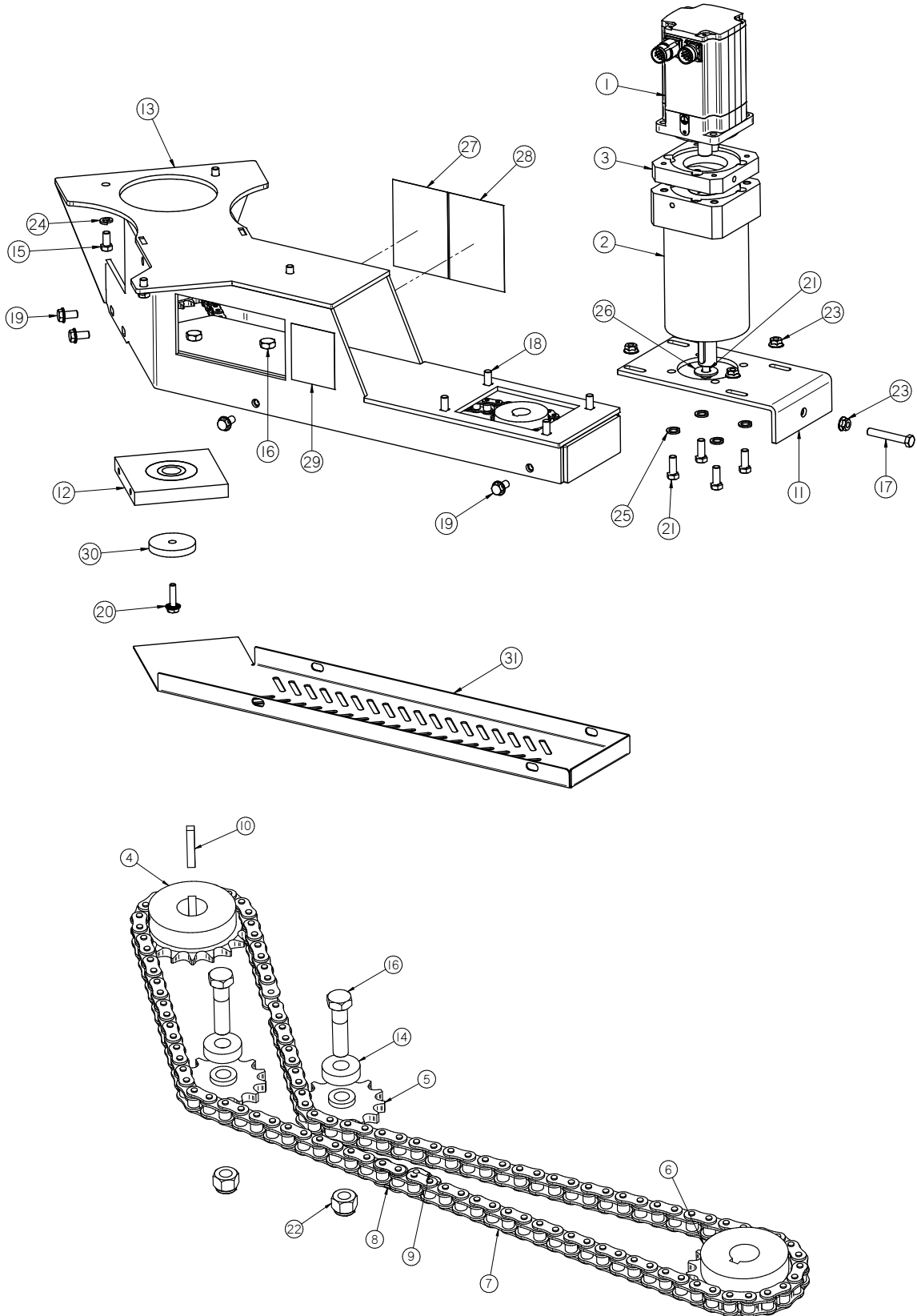

**SERVO DRIVE ASSEMBLY (05-07-0917) VERSION 4HC)**

Item #	Part #	Description	Qty
1	01-01-0203	SERVO MTR BMH1002T07A2A	1
2	01-01-0204	SERVO MTR GEARBOX 120MM RATIO 40	1
3	01-01-0205	SERVO MTR GEARBOX KIT SIZE 120 BMH	1
4	01-02-0096	SPKT #50 18T WITH 1 FNSH BORE	1
5	01-02-0115	SPKT 13T 50P .500ID IDLER	2
6	01-02-0122	SPKT 18T 50P 25MM BORE 8MM KEYWAY	1
7	01-04-0002	CHAIN RLR 50	1
8	01-04-0005	CHAIN CTNG LINK 50P	1
9	01-04-0007	#50 OFFSET LINK	1
10	01-10-0005	1/4" KEY, CS - 1 1/2" LONG	1
11	05-03-1523	WDMT BRUT GBOX MNT SERVO DRV	1
12	05-04-0120	ASSY LOWER SHAFT CNTNS FLOW SYSTEM	1
13	05-04-0202	WDMT SLTR DRV CNTNS FLOW SYSTEM	1
14	05-10-3811	WSHR .500 ID X 1.25 OD X .375 THK	2
15	06-01-0015	BOLT .375-16 X 0.75 ZP GR5	4
16	06-01-0027	BOLT .500-13 X 2.00 ZP GR5	2
17	06-01-0071	BOLT .375-16 X 2.50 ZP GR5	1
18	06-01-0115	BOLT CRG .375-16 X 1.00 ZP GR5	4
19	06-01-0124	BOLT FLAG .375-16 X .750 ZP GR5	8
20	06-01-0189	BOLT FLAG .375-16 X 1.250 ZP GR5	1
21	06-01-0295	BOLT M10-1.5 X 25MM ZP	5
22	06-03-0004	NUT NYL LOCK .500-13 ZP GR5	2
23	06-03-0014	NUT LOCK FLAG .375-16 ZP GR5	5
24	06-04-0003	WSHR LOCK SPLT .375 ZP	4
25	06-04-0011	WASHER, .4375 LOCK ZP	4
26	06-05-0020	WASHER, .4375 FLAT ZP	1
27	09-02-0001	ATWK LBL DANGER FINGERS	1
28	09-02-0002	ATWK LBL DANGER GUARDS	1
29	09-02-0009	ATWK LBL WARNING ROTATING PARTS	1
30	10224D	WSHR	1
31	10561F	GRD SLTR CHAIN DRV	1



**HOPPER ASSEMBLY (05-07-0889) VERSION 4HC**

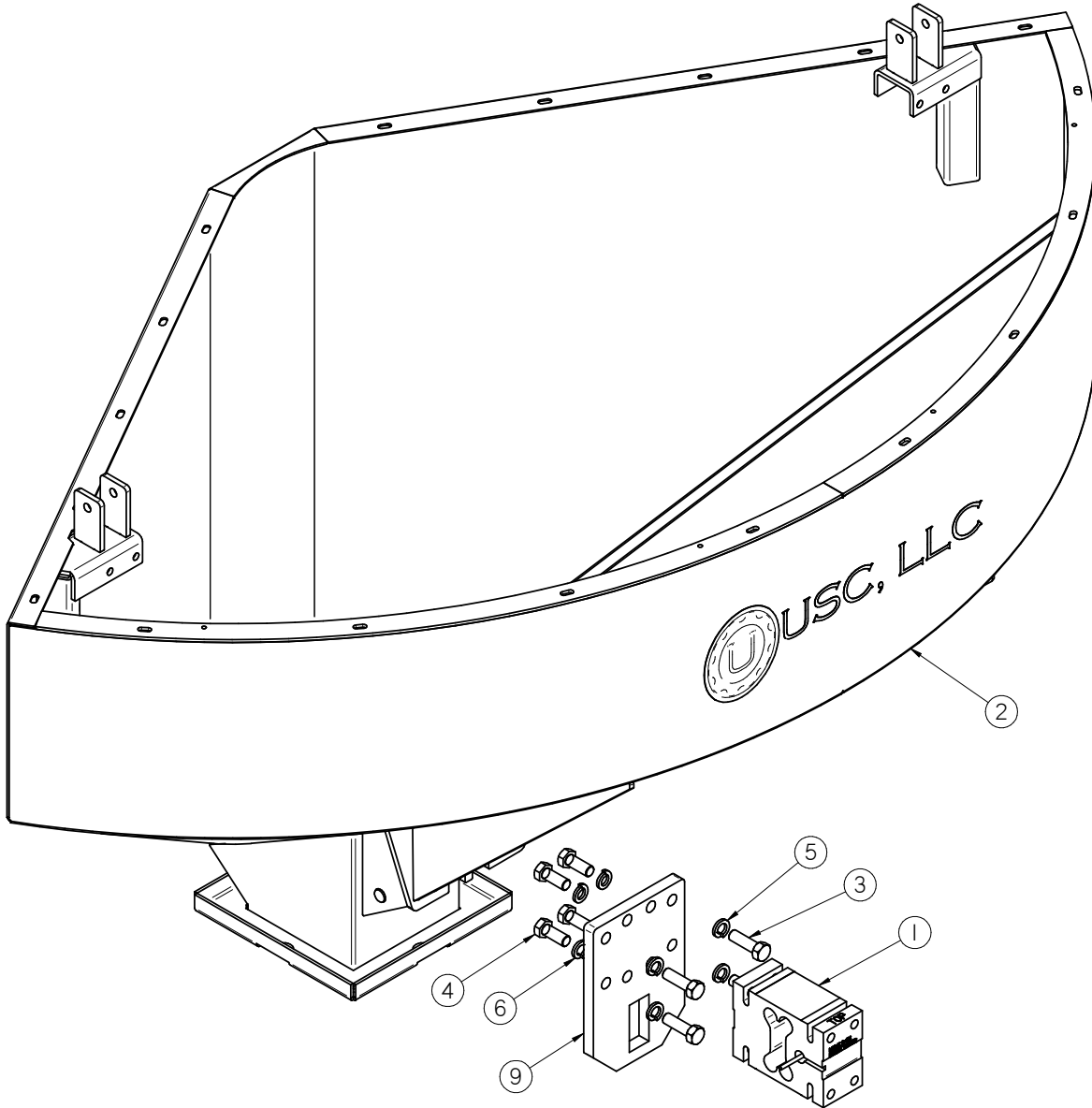

Item #	Part #	Description	Qty
1	03-19-0042	LDCL VISHAY 1320 2200LB CLASS III	1
2	05-03-1666	WDMT HOPP WEDGE 30 UNIT OPEN TOP	1
3	06-01-0032	BOLT, .625 X 11 X 2" UNC ZP GRADE 5	4
4	06-01-0228	BOLT M16-2.00 X 40MM FTH	4
5	06-04-0005	WASHER, .625 LOCK ZP	4
6	06-04-0018	WSHR LOCK SPLT M16 ZP	4
7	09-01-0043	ATWL LBL USC, LLC 6" X 19" PRO-CUT	1
8	09-02-0019	LBL ATWRK TRI-FLO LOGO	1
9	102349	PLT LDCL ATTACH	1

**DISTRIBUTION DRIVE ASSEMBLY (05-07-0891) VERSION 4HC**

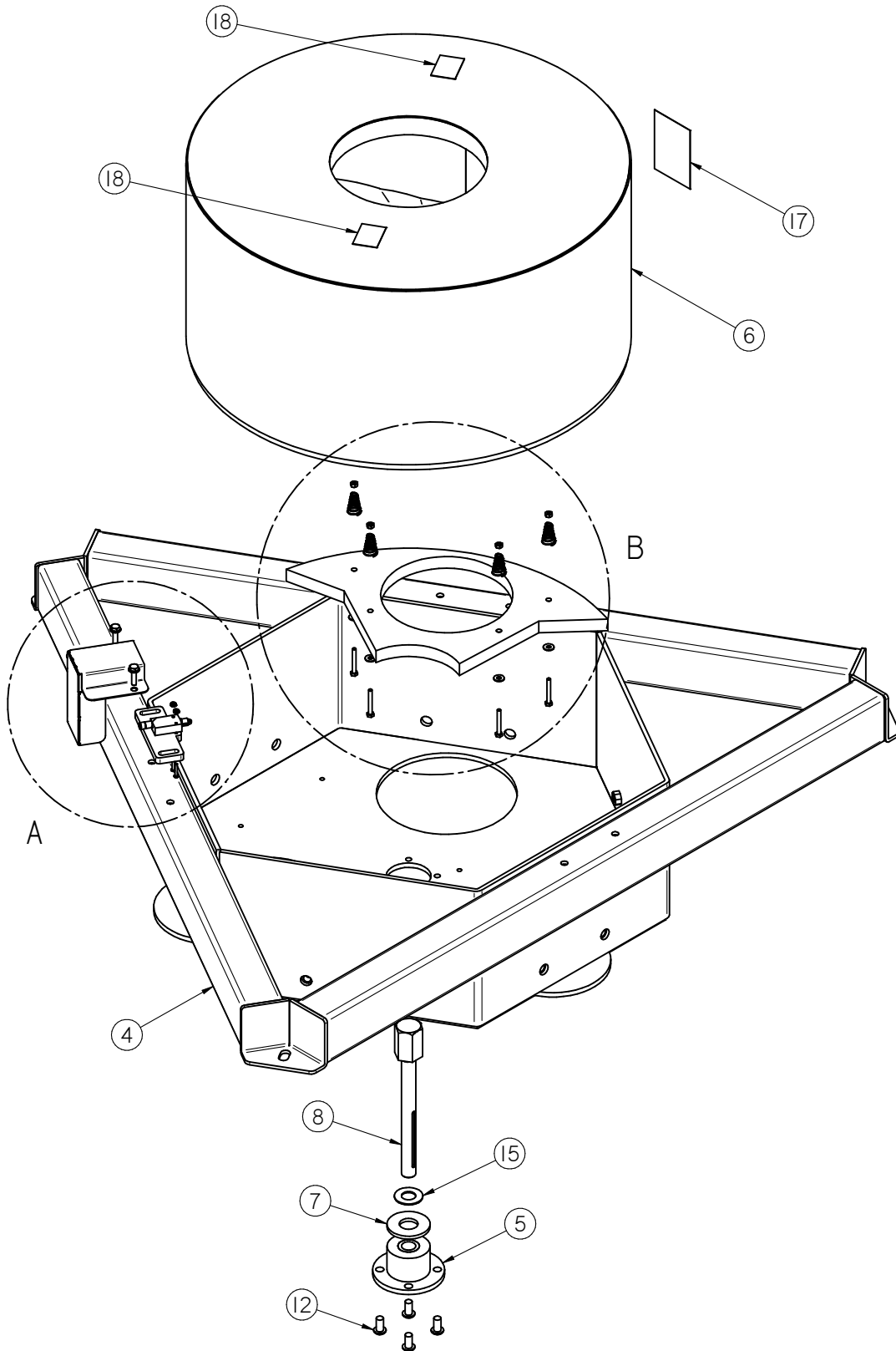

**DISTRIBUTION DRIVE ASSEMBLY (05-07-0891) VERSION 4HC**

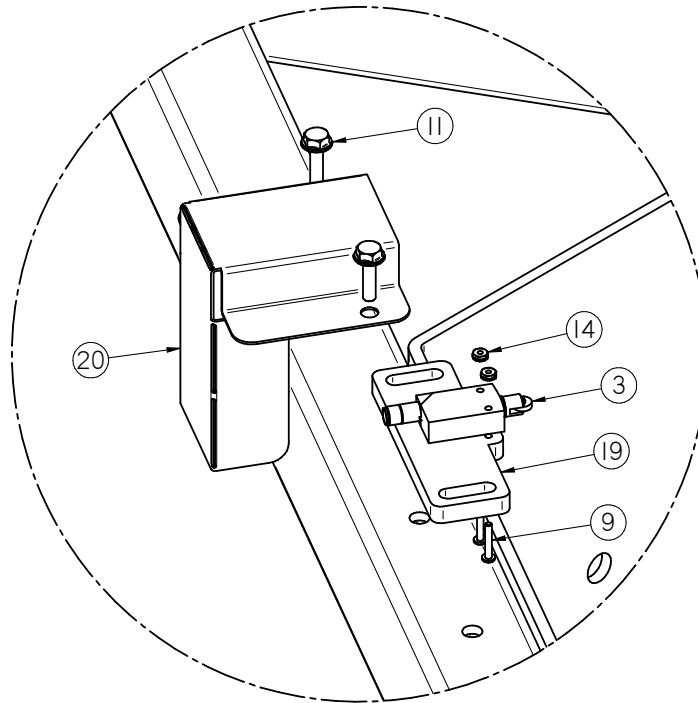

DETAIL A

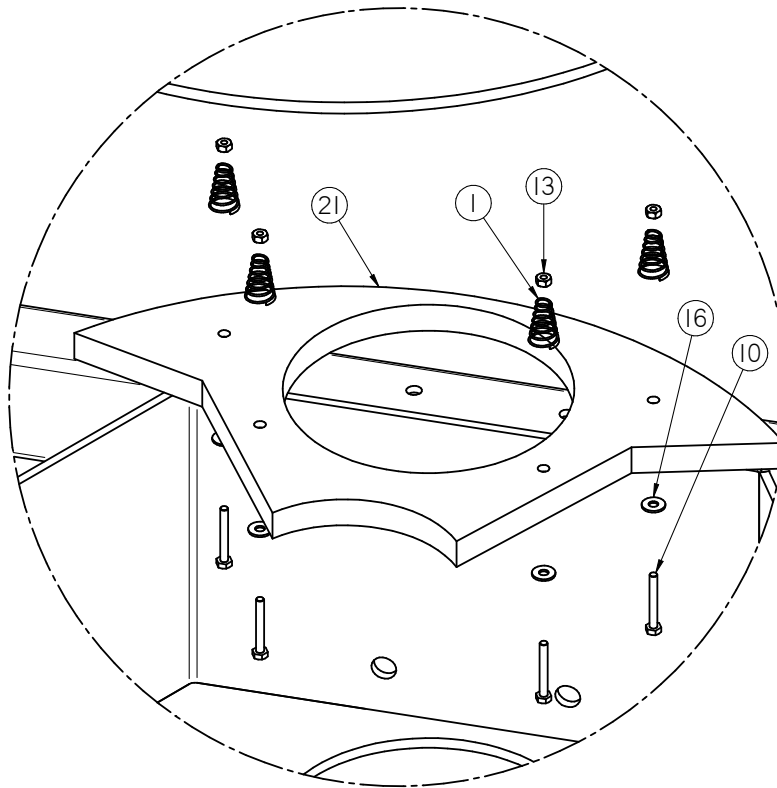

DETAIL B

**DISTRIBUTION DRIVE ASSEMBLY (05-07-0891) VERSION 4HC**

Item #	Part #	Description	Qty
1	01-04-0094	SPG CNCL COMP .26ID X .055 X 1.50 LG	4
2	03-08-0316	CONN TRCK RK4.4T-8-RS4.4T/S760/S771	2
3	03-10-0125	SW LMT SCHDR XCMD21202C12	1
4	05-03-1667	WDMT SLTR HSG CNTNS FLOW SYSTEM SMW	1
5	05-04-0118	ASSY SLTR BRG HSG CNTNS FLOW SYSTEM	1
6	05-07-0892	WDMT SLTR SPOUT CNTNS FLOW SYS 30U	1
7	05-10-3821	WSHR .25THK X 1.313ID X 3.00OD	1
8	05-11-0412	SHAFT DIST DRV 1.75 HEX	1
9	06-01-0094	SCRW PAN HD 8-32 X 1.00 ZP	2
10	06-01-0097	BOLT .250-20 X 2.00 ZP GR5	4
11	06-01-0189	BOLT FLAG .375-16 X 1.250 ZP GR5	2
12	06-01-0224	BOLT CAP .500-13 X 1.00 BTNH	4
13	06-02-0001	NUT FULL .250-20 ZP GR5	4
14	06-02-0034	NUT 8-32 K-LOCK ZP	2
15	06-04-0016	WSHR THRST 1.0 X 1.99 X .088 PCMPST	1
16	06-05-0001	WASHER, FLAT .250	4
17	09-02-0001	ATWK LBL DANGER FINGERS	1
18	09-02-0022	ATWK LBL DANGER AUTO START	2
19	10215E	PLT DIST PROOF SW BRUT CS	1
20	103929	SWITCH GUARD	1
21	105270	PLT UHMW DIST SLIDING SEAL	1

**TRI - FLO® TOP ASSEMBLY (05-07-0888) VERSION 4HC**

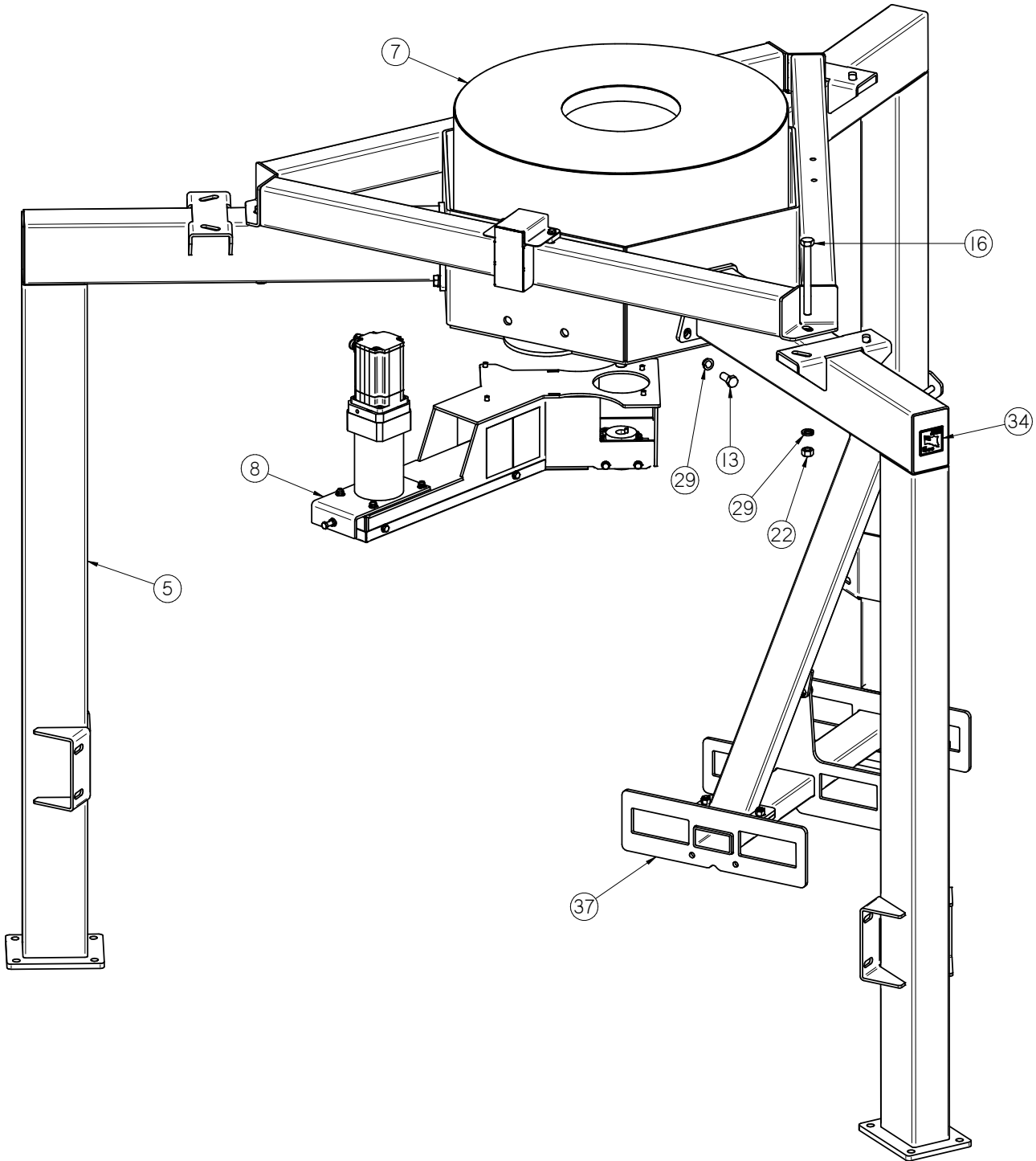

**TRI - FLO® TOP ASSEMBLY (05-07-0888) VERSION 4HC**

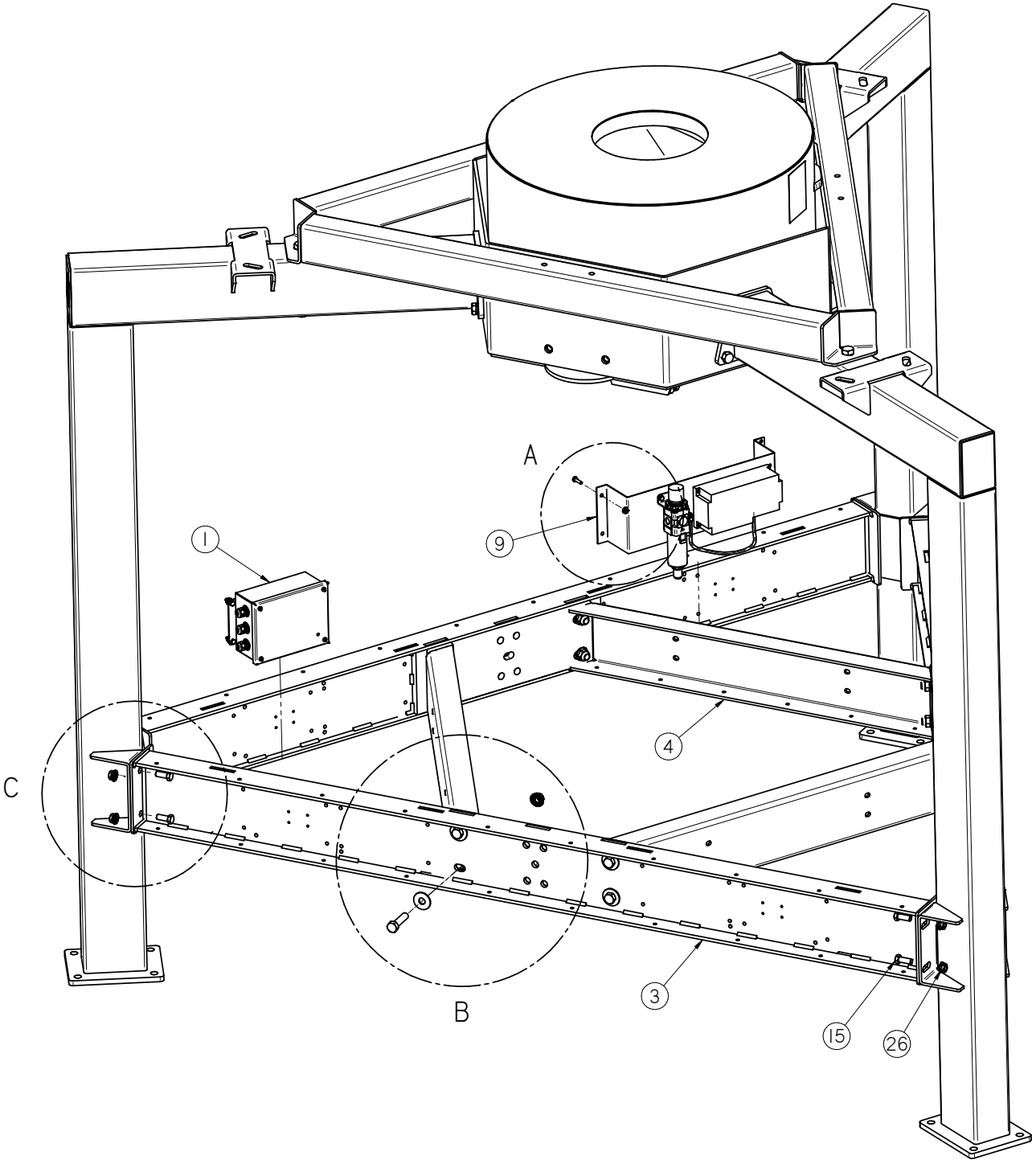

**TRI - FLO® TOP ASSEMBLY (05-07-0888) VERSION 4HC**

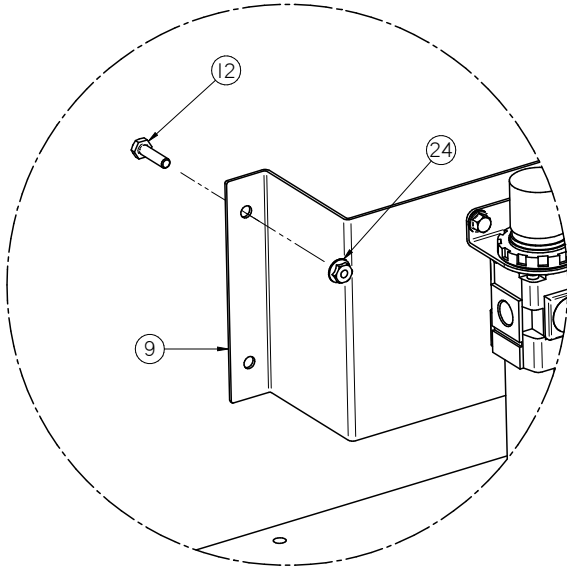

DETAIL A

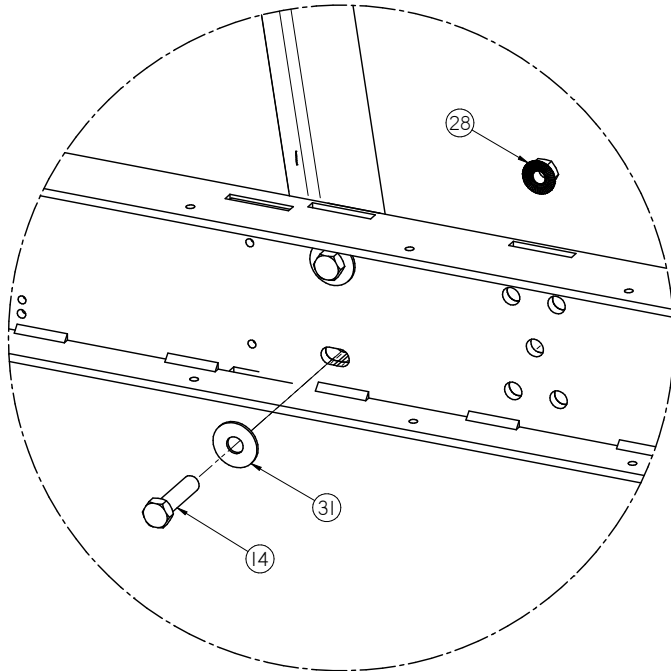

DETAIL B

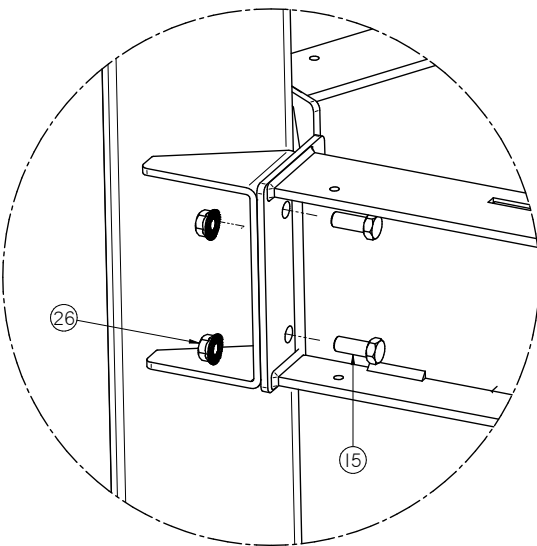

DETAIL C



**TRI - FLO® TOP ASSEMBLY (05-07-0888) VERSION 4HC**

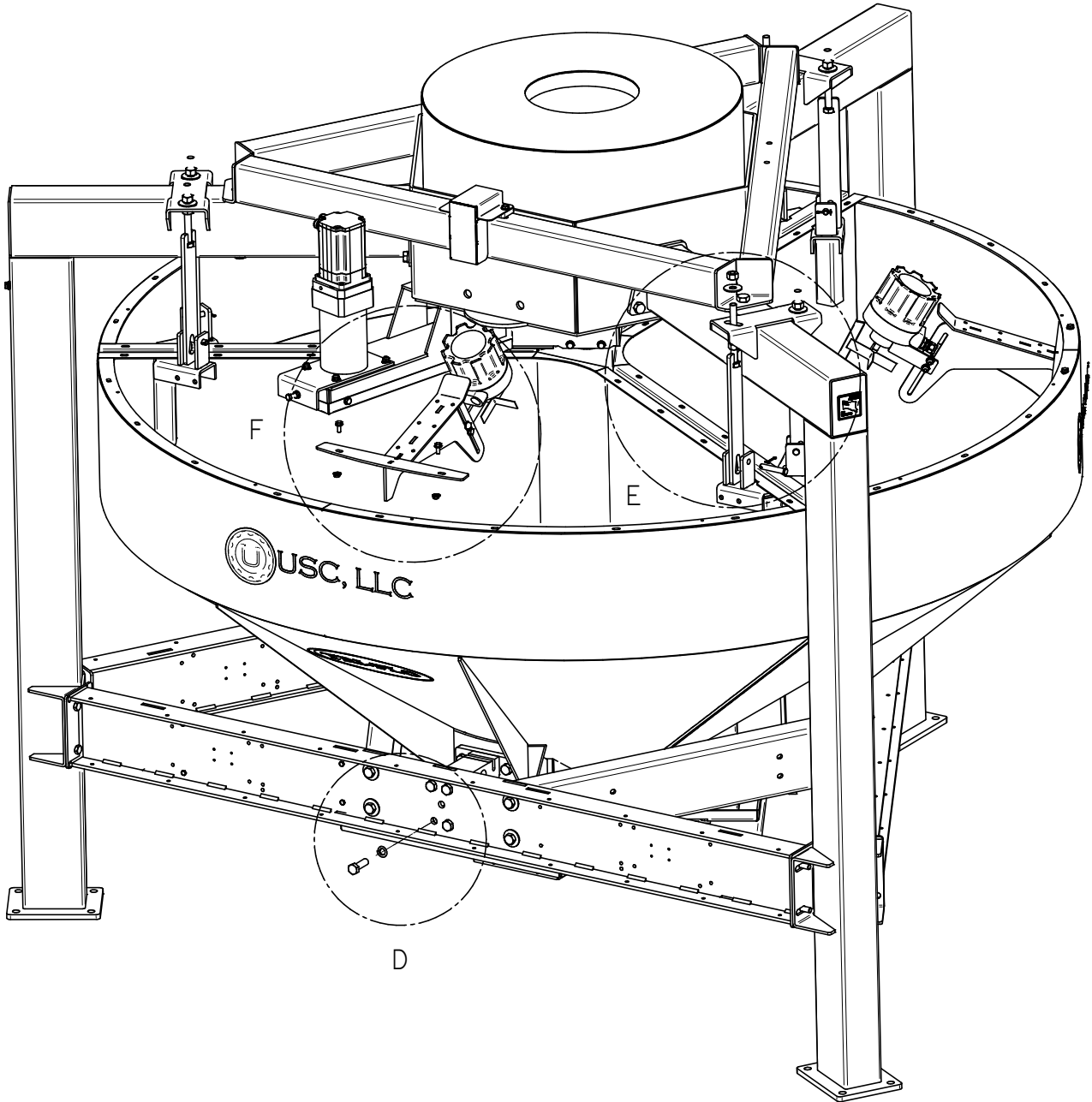

**TRI - FLO® TOP ASSEMBLY (05-07-0888) VERSION 4HC**

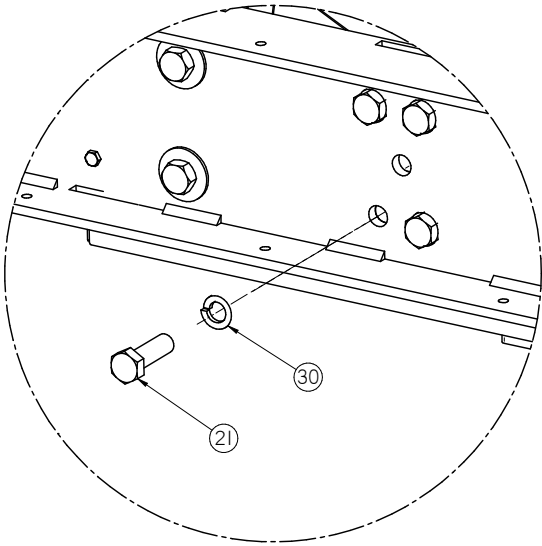

DETAIL D

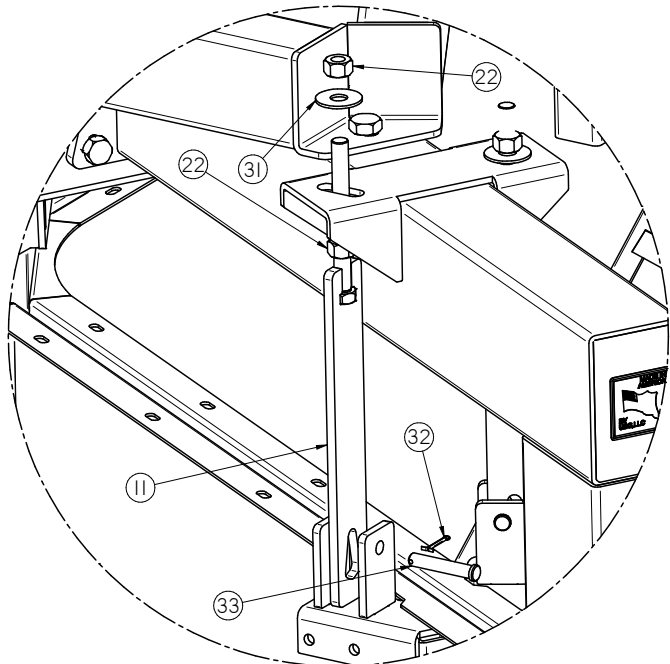

DETAIL E

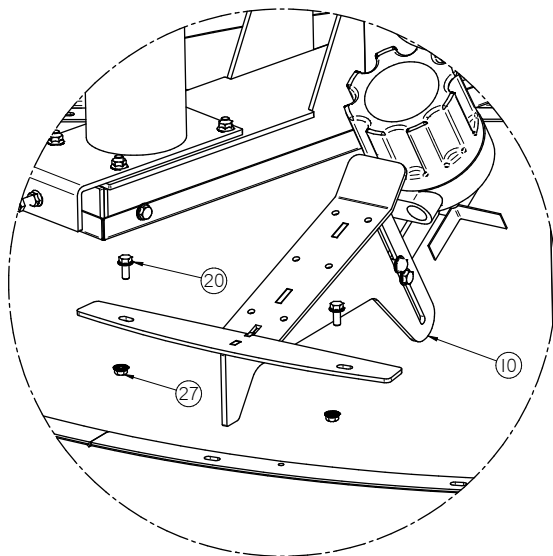

DETAIL F

**TRI - FLO® TOP ASSEMBLY (05-07-0888) VERSION 4HC**

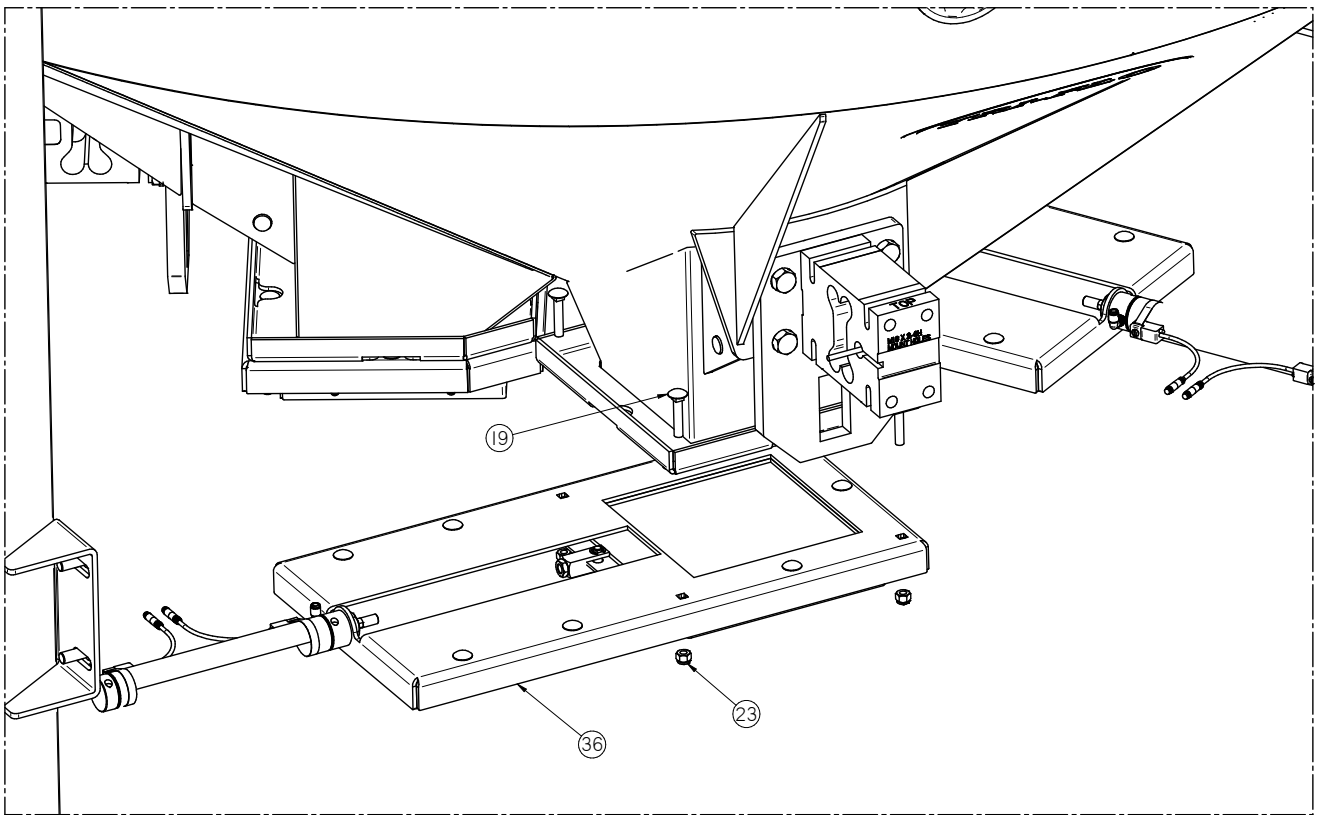

**TRI - FLO® TOP ASSEMBLY (05-07-0888) VERSION 4HC**

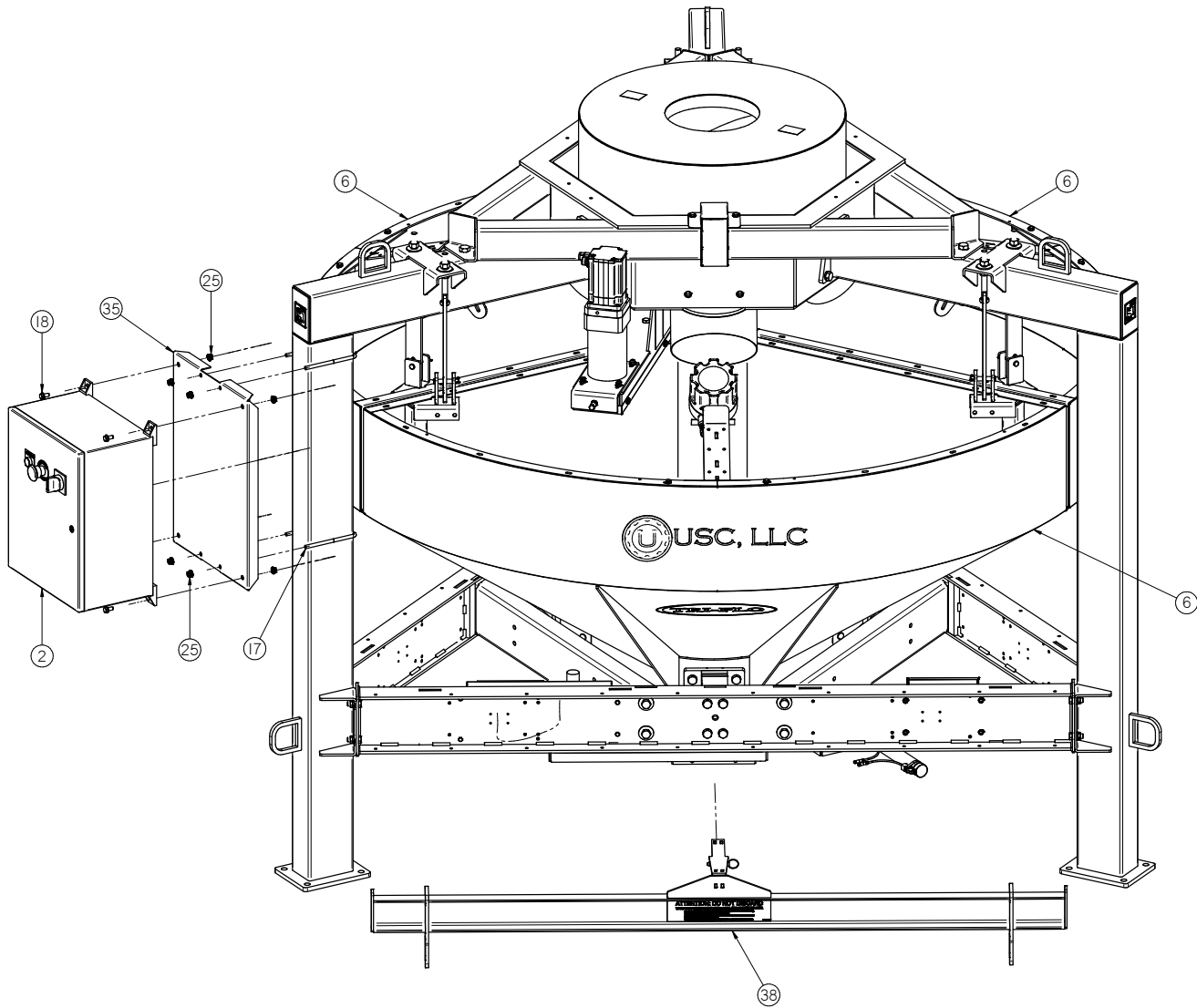

Item #	Part #	Description	Qty
1	03-12-0364	PNL LOAD CELL JCT BOX TRI FLO	1
2	03-12-0552	PNL CNTL V4 TRI-FLO SERVO DRV PNL	1
3	05-03-0900	WDMT LEG BRACE CNTNS FLOW SYSTEM	3
4	05-03-1008	WDMT BRACE LDCL PLT	3
5	05-05-0156	WDMT LEG CNTNS FLOW WH SYS OPEN TOP	3
6	05-07-0889	ASSY HOPP TRI FLO	3
7	05-07-0891	ASSY DIST TRI FLO HC	1

**TRI - FLO® TOP ASSEMBLY (05-07-0888) VERSION 4HC**

Item #	Part #	Description	Qty
8	05-07-0917	ASSY SERVO DRV TRI FLO	1
9	05-07-0969	ASSY SMC VLV & REGL TRI FLO V4	1
10	05-07-0974	ASSY HIGH LVL INDI TRI FLO V4	3
11	05-09-0045	WDMT HOPP SUPP STRAP TRI-FLO	6
12	06-01-0007	BOLT, .250-20 X 1 UNC ZP GRADE 5	4
13	06-01-0031	BOLT,.625-11 G5 ZP 1.50	6
14	06-01-0075	BOLT, .625 X 11 X 2.50" UNC ZP GRADE 5	12
15	06-01-0080	BOLT .500-13 X 1.25 ZP GR5	12
16	06-01-0096	BOLT .625-11 X 7.00 ZP GR5	3
17	06-01-0113	BOLT U .375-16 X 4.00 X 6.625 ZP	2
18	06-01-0124	BOLT FLAG .375-16 X .750 ZP GR5	4
19	06-01-0136	BOLT CRG .375-16 X 2.00 ZP GR5	9
20	06-01-0138	BOLT, FLAG .3125-18 UNC ZP GRADE 5; 3/4" LG	6
21	06-01-0230	BOLT M16-2.00 X 50MM FTH	12
22	06-02-0005	NUT, .625-11 UNC ZP GRADE 5	15
23	06-03-0003	NUT NYL LOCK .375-16 ZP GR5	9
24	06-03-0013	NUT,LOCK, FLAG .250-20 ZP SERRATED	4
25	06-03-0014	NUT LOCK FLAG .375-16 ZP GR5	8
26	06-03-0015	NUT LOCK FLAG .500-13 ZP GR5	12
27	06-03-0019	NUT LOCK FLAG .3125-18 ZP GR5	6
28	06-03-0029	NUT WHIZ LOCK FLAG .625-11 GR5	12
29	06-04-0005	WASHER, .625 LOCK ZP	9
30	06-04-0018	WSHR LOCK SPLT M16 ZP	12
31	06-05-0006	WASHER, .625 FLAT ZP	18
32	06-09-0018	PIN CTTR .125 X 1.50 SS	6
33	06-09-0058	PIN CLVS .500 X 2.75 PLN	6
34	09-01-0003	ATWK LBL MADE IN USA YEL 2.50X2.50	3
35	102B71	BRUT TRI-FLO PNL	1
36	12-04-0042	SLIDE GATE 8.00 SQ TRI-FLO	3
37	13-05-0268	KIT FORK PCKT ASSY TRI-FL	1
38	13-05-0598	KIT WEIGHT BAR TRI-FLOW	1

**TRI - FLO® MOUNT ADJUSTABLE CHAMBER ASSEMBLY (18-01-0365)**

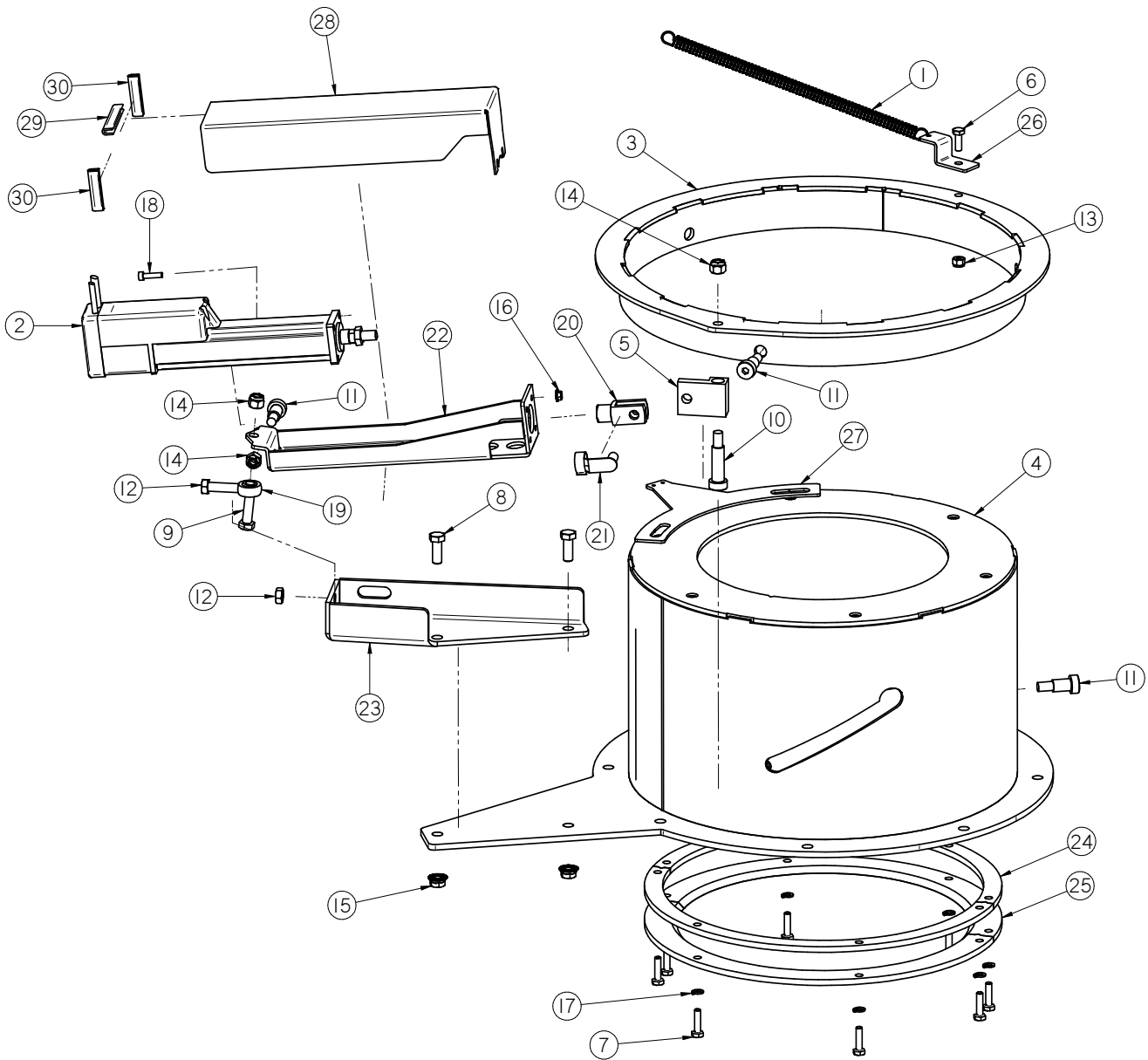

**TRI - FLO® MOUNT ADJUSTABLE CHAMBER ASSEMBLY (18-01-0365)**

Item #	Part #	Description	Qty
1	01-04-0093	SPG EXT .500D .055 WIRE 5.0IN LG	1
2	03-20-0162	KIT ACTR W CONNECTORS	1
3	05-04-0169	WDMT RING DRV LIW SLEEVE	1
4	05-07-0852	WDMT LIW CHAMBER	1
5	05-11-0394	BRUT FLOW CNTL CLVS 10 MM	1
6	06-01-0006	BOLT .250-20 X .750 ZP GR5	1
7	06-01-0007	BOLT, .250-20 X 1 UNC ZP GRADE 5	8
8	06-01-0016	BOLT .375-16 X 1.00 ZP GR5	2
9	06-01-0053	BOLT .375-16 X 1.25 ZP GR5	1
10	06-01-0057	BOLT SHLD .500SHX.375-16X1.50 GR5	1
11	06-01-0278	BOLT SHLD .500SHX.375-16X.750 GR5	4
12	06-02-0035	NUT JAM .375-24 ZP GR5	2
13	06-03-0001	NUT,LOCK, .250-20 ZP G5 NYLON INSERT	1
14	06-03-0003	NUT NYL LOCK .375-16 ZP GR5	3
15	06-03-0014	NUT LOCK FLAG .375-16 ZP GR5	2
16	06-03-0031	NUT LOCK FLAG M5-0.8 GR8.8	4
17	06-04-0001	WSHR LOCK SPLT .250 ZP	8
18	06-06-0083	SCRW SH M5-0.8 X 20MM BO	4
19	06-12-0003	REND .375-24 BALL RH	1
20	06-12-0043	CLVS 10-1.25 X 10MM	1
21	06-12-0044	PIN CLIP SPRING 10MM	1
22	102EEA	BRUT DYATIC SCN5-010-150 ACTUATOR	1
23	102EEB	BRKT CYL BASE	1
24	1044AB	SPACER	2
25	1044EB	SEAL	2
26	10501D	SPRING BRKT	1
27	105020	SPRING BRKT	1
28	105172	CVR ACTR LIW ADJ CHMBR	1
29	1056F1	ACTR CVR EDGING	1
30	1056F2	ACTR CVR EDGING	2



**TRI - FLO® MOUNT LIW CHAMBER ASSEMBLY (18-01-0376)**

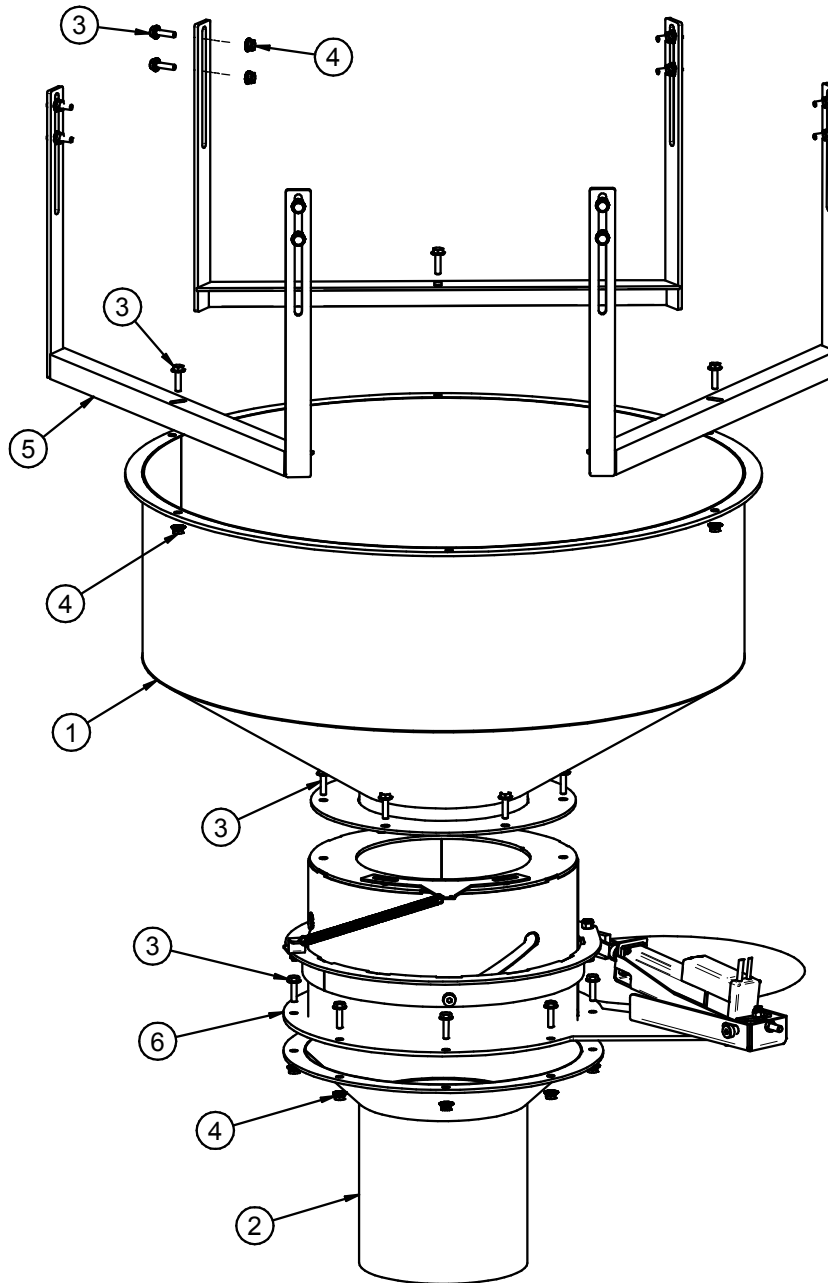

Item #	Part #	Description	Qty
1	05-07-0853	WDMT TRI FLO LIW CONE	1
2	05-07-0854	WDMT LIW CHAMBER DSCHG CONE	1
3	06-01-0189	BOLT FLAG .375-16 X 1.250 ZP GR5	29
4	06-03-0014	NUT LOCK FLAG .375-16 ZP GR5	23
5	1021B2	WDMT CONE SUPP	3
6	18-01-0365	ASSY AD CHMBR LIW 2000 FLR MNT	1

# USC LIMITED WARRANTY

## SECTION J

USC, LLC, (Manufacturer) warrants its seed treating equipment as follows:

1. **Limited Warranty:** Manufacturer warrants that the Products sold hereunder will be free from defects in material and workmanship for a period of 18 months from date of shipment. If the Products do not conform to this Limited Warranty during the warranty period, Buyer shall notify Manufacturer in writing of the claimed defects and demonstrate to Manufacturer satisfaction that said defects are covered by this Limited Warranty. If the defects are properly reported to Manufacturer within the warranty period, and the defects are of such type and nature as to be covered by this warranty, Manufacturer shall, at its expense, furnish replacement Products or, at Manufacturer's option, replacement parts for the defective products. Shipping and installation of the replacement Products or replacement parts shall be at the Buyer's expense.

2. **Other Limits:** THE FOREGOING IS IN LIEU OF ALL OTHER WARRANTIES, EXPRESSED OR IMPLIED, INCLUDING BUT NOT LIMITED TO THE IMPLIED WARRANTIES OF MERCHANTABILITY AND FITNESS FOR A PARTICULAR PURPOSE. Manufacturer does not warrant against damages or defects arising from improper installation (where installation is by persons other than Manufacturer), against defects in products or components not manufactured by Manufacturer, or against damages resulting from such non-Manufacturer made products or components. Manufacturer passes on to the Buyer the warranty it received (if any) from the maker of such non-Manufacturer made products or components. This warranty also does not apply to Products upon which repairs and / or modifications have been effected or attempted by persons other than pursuant to written authorization by Manufacturer. This includes any welding on equipment which could damage electrical components. Manufacturer does not warrant against casualties or damages resulting from misuse and / or abuse of Products, improper storage or handling, acts of nature, effects of weather, including effects of weather due to outside storage, accidents, or damages incurred during transportation by common carrier.

3. **Exclusive Obligation:** THIS WARRANTY IS EXCLUSIVE. The sole and exclusive obligation of Manufacturer shall be to repair or replace the defective Products in the manner and for the period provided above. Manufacturer shall not have any other obligation with respect to the Products or any part thereof, whether based on contract, tort, strict liability or otherwise. Under no circumstances, whether based on this Limited Warranty or otherwise, shall Manufacturer be liable for lost profits, lost revenue, lost sales (whether direct or indirect damages), incidental, special, punitive, indirect or consequential damages.

4. **Other Statements:** Manufacturer's employees or representatives' oral or other written statements do not constitute warranties, shall not be relied upon by Buyer, and are not a part of the contract for sale or this limited warranty.

5. **Return Policy:** Approval is required prior to returning goods to Manufacturer. A restocking fee will apply.

6. **Entire Obligation:** This Limited Warranty states the entire obligation of Manufacturer with respect to the Products. If any part of this Limited Warranty is determined to be void or illegal, the remainder shall remain in full force and effect.

US / Canada Non-Exclusive 2016



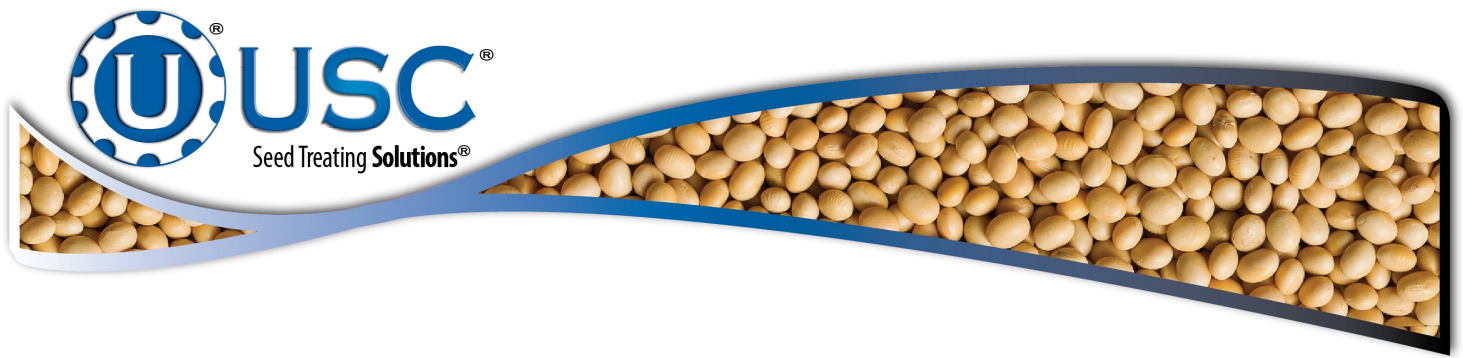

**USC, LLC**

2320 124th road

Sabetha, KS 66534

PHONE: (785) 431-7900

FAX: (785) 431-7950

EMAIL: [sales-team@uscllc.com](mailto:sales-team@uscllc.com)

WEB: [www.uscllc.com](http://www.uscllc.com)

---