

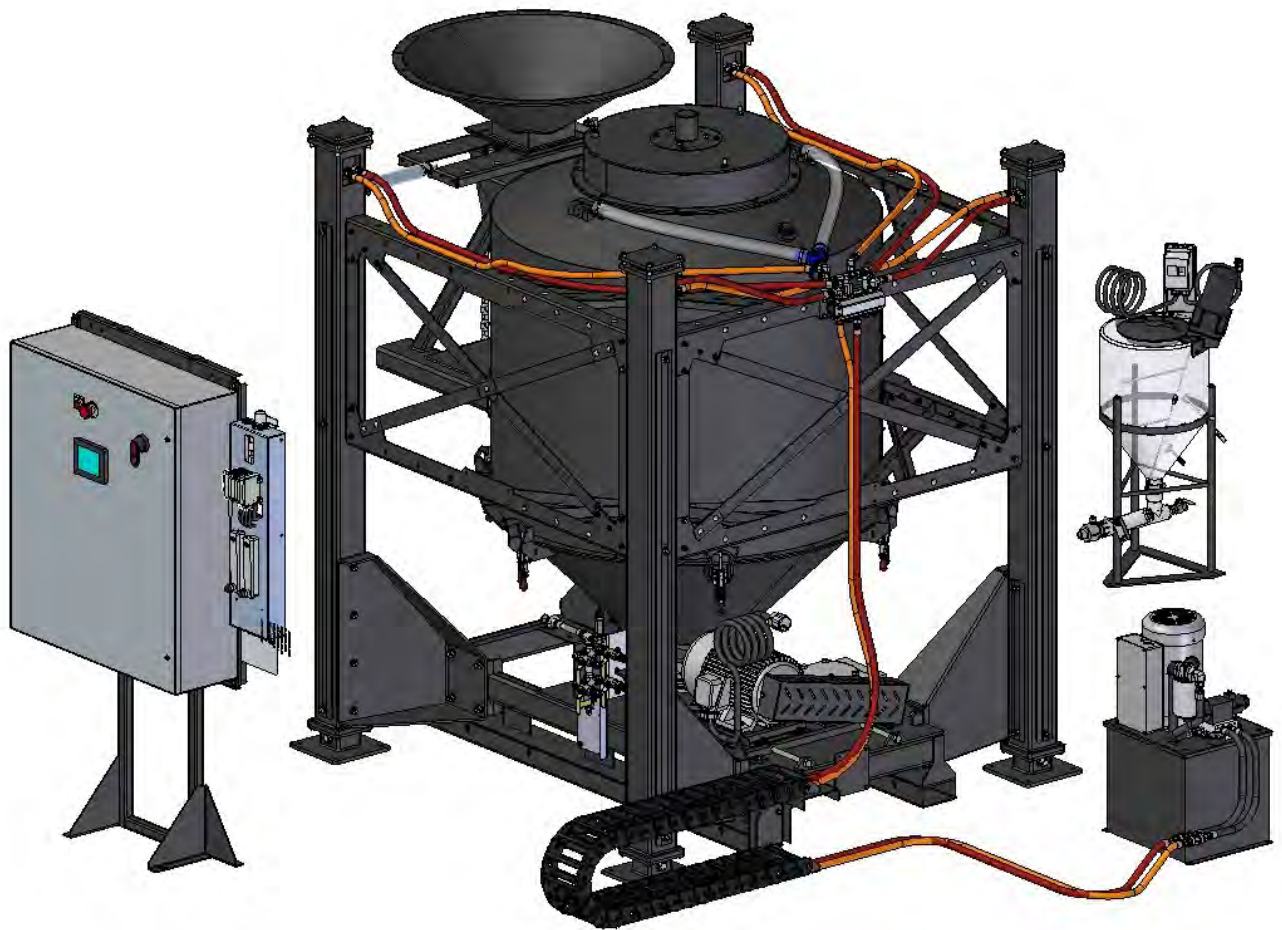

U-BATCH™ TREATER

Operators Manual



Software Release: U-Batch™ v2.1

Document: TD-09-06-1040

Revision: C



INTRODUCTION

Thank you for choosing USC, LLC for your equipment needs. We appreciate your business and will work diligently to ensure that you are satisfied with your choice.

OVERVIEW

The purpose of this manual is to provide you with the basic information needed to operate and maintain the U-Batch™ Treater. It does not hold USC, LLC liable for any accidents or injuries that may occur.

The technical information provided in this document is based on extensive testing under controlled conditions at the USC research and development facility. This information is given without guarantee as the conditions of operation and storage of the equipment are beyond our control. Variables such as temperature, humidity, viscosity of chemical products and changes in seed size or variety may all effect the accuracy of application and seed coverage. Periodically check the equipment calibration while treating and make adjustments as required. This will insure the optimum seed coverage.

OPERATOR RESPONSIBILITIES

As the purchaser/owner/operator of this equipment and control system, you have an obligation to install, operate, and maintain the equipment in a manner that minimizes the exposure of people in your care to any potential hazards inherent in using this equipment. It is critical that the owner of this equipment:

- Has a clear and documented understanding of the process this machine is being used in and of any resulting hazards or special requirements arising from this specific application.
- Allow only properly trained and instructed personnel to install, operate or service this equipment.
- Maintain a comprehensive safety program involving all who work with this machine and other associated process equipment.
- Establish clear areas of staff responsibility (e.g. operation, setup, sanitation, maintenance, and repairs).
- Provide all personnel with necessary safety equipment.
- Periodically inspect the equipment to insure that the doors, covers, guards, and safety devices are in place and functioning, that all safety instructions and warning labels are intact and legible, and that the equipment is in good working order.
- In addition to the operating instructions, observe and enforce the applicable legal and other binding regulations, national and local codes.

U-BATCH™ TREATER

As the person with the most to gain or lose from working safely, it is important that you work responsibly and stay alert. By following a few simple rules, you can prevent an accident that could injure or kill you or a co-worker.

- Disconnect, lockout, and tagout electrical and all other energy sources before inspecting, cleaning, servicing, repairing, or any other activity that would expose you to the hazards of electrical shock.
- Do not operate, clean, or service this equipment until you have read and understood the contents of this manual. If you do not understand the information in this manual, bring it to the attention of your supervisor, or call USC at (785) 431-7900 for assistance.
- Any operator who is known or suspected to be under the influence of alcohol or drugs should not be allowed to operate the equipment.
- Understand and follow the safety practices required by your employer and this manual.
- **PAY ATTENTION** to what you and other personnel are doing and how these activities may affect your safety.
- **Failure to follow these instructions may result in serious personal injury or death.**

RECEIVING YOUR EQUIPMENT

As soon as the equipment is received, it should be carefully inspected to make certain that it has sustained no damage during shipment and that all items listed on the packing list are accounted for. If there is any damage or shortages, the purchaser must immediately notify USC, LLC. Ownership passes to purchaser when the unit leaves the USC, LLC. premises. The purchaser is responsible for unloading and mounting all components of the equipment.

Document the serial number of the machine for future reference. The serialization label is located on the base frame near the discharge chute.



*Serial
Number*

SERIAL NUMBER: _____

TABLE OF CONTENTS

<u>Section</u>	<u>Contents</u>	<u>Page #</u>
Section A	Safety Instructions.....	5
Section B	Installation	14
Section C	Mechanical Operation.....	21
	U-Batch™ Treater Overview	21
	Hydraulic Lift Overview	22
	Control Panel Overview.....	23
Section D	Electrical Operation	24
	Start Up Screen	25
	Main Screen	26
	Load / Unload Screen	31
	Pump Screen	32
	Utilities Screen	37
	H-O-A Screens.....	38
	Tools & Options Screen	43
	Security Screen	44
	Setpoints Screens	45
	Alarms Screen.....	50
Section E	Treating Seed	52
Section F	Troubleshooting.....	54
Section G	Maintenance	55
Section H	Belt Tensioning Specifications.....	58
Section I	Storage.....	59
Section J	Mechanical Drawings	61
Section K	Limited Warranty.....	117

SAFETY INSTRUCTIONS

SECTION A

Every year accidents in the work place maim, kill and injure people. Although it may be impossible to prevent all accidents, with the right combination of training, operating practices, safety devices, and operator vigilance, the number of accidents can be significantly reduced. The purpose of this section is to educate equipment users about hazards, unsafe practices, and recommended hazard avoidance techniques.

SAFETY WORDS AND SYMBOLS

It is very important that operators and maintenance personnel understand the words and symbols that are used to communicate safety information. Safety words, their meaning and format, have been standardized for U.S. manufacturers and published by the American National Standards Institute (ANSI). The European Community (E.C.) has adopted a different format based on the International Standards Organization (I.S.O.) and applicable machinery directives. Both formats are presented below. Graphic symbols are not standardized, but most manufacturers will use some variation of the ones seen in this manual.



Indicates an imminently hazardous situation which, if not avoided, **will** result in death or serious injury.



Indicates a potentially hazardous situation which, if not avoided, **could** result in death or serious injury.



Indicates a potentially hazardous situation which, if not avoided, **may** result in minor or moderate injury and/or property damage.



Provides additional information that the operator needs to be aware of to avoid a potentially hazardous situation.



Mandatory Lockout Power Symbol. Disconnect, lockout and tagout electrical and other energy sources before inspecting, cleaning or performing maintenance on this panel.



International Safety Alert Symbol. The exclamation point (!) surrounded by a yellow triangle indicates that an injury hazard exists. However, it does not indicate the seriousness of potential injury. The exclamation point (!) is also used with the DANGER, WARNING and CAUTION symbols so the potential injury is indicated.



Electrocution Hazard Symbol. This symbol indicates that an electrocution hazard exists. Serious injury or death could result from contacting high voltage.



International Electrocution Hazard. This symbol indicates that an electrocution hazard exists. Serious injury or death could result from contacting high voltage.



Mandatory Read Manual Action Symbol. (I.S.O. format) This symbol instructs personnel to read the Operators Manual before servicing or operating the equipment.



Mandatory Read Manual Action Symbol. This symbol instructs personnel to read the Operators Manual before servicing or operating the equipment.

NOTICE

Notice is used to notify people of important installation, operation or maintenance information which is not hazard related.

LOCKOUT / TAGOUT PROCEDURES

Lockout/Tagout is the placement of a lock/tag on an energy isolating device in accordance with an established procedure. When taking equipment out of service to perform maintenance or repair work, always follow the lockout/tagout procedures as outlined in ANSI Z344.1 and/or OSHA Standard 1910.147. This standard “requires employers to establish a program and utilize procedures for affixing appropriate lockout devices or tagout devices to energy isolating devices and to otherwise disable machines or equipment to prevent unexpected energizing, start-up, or release of stored energy in order to prevent injury to employees.”

EMERGENCY STOP



There is an Emergency Stop push button on the U-Batch™ Treater which is located on the Main Control Panel. Actuators of emergency stop shall be colored RED. The background immediately around the device actuator shall be colored YELLOW. The actuator pushbutton operated device shall be of the palm or mushroom head type.

CONTROLLED STOP

This is the stopping of machine motion by reducing the electrical command signal to 0 (zero) once the stop signal has been recognized. The operator initiates this stop by pressing the PAUSE button at the bottom of the main screen.

HAZARD REVIEW

Electrocution Hazard



Electrocution accidents are most likely to occur during maintenance of the electrical system or when working on or near exposed high voltage wiring. This hazard does not exist when the electrical power has been disconnected, properly locked, and tagged out.

Automatic Start Hazard



This equipment may be controlled by an automated system and may start without warning. Failure to properly disconnect, lockout, and tagout all energy sources of remotely controlled equipment creates a very hazardous situation and could cause injury or even death. PLEASE STAY CLEAR AND BE ALERT.

YOU are responsible for the **SAFE** operation and maintenance of your USC, LLC equipment . **YOU** must ensure that you and anyone else who is going to operate, maintain or work around the equipment be familiar with the operating and maintenance procedures and related **SAFETY** information contained in this manual. This manual will take you step-by-step through your working day and alert you to good safety practices that should be adhered to while operating the equipment

Remember, **YOU** are the key to safety. Good safety practices not only protect you, but also the people around you. Make these practices a working part of your safety program. Be certain that **EVERYONE** operating this equipment is familiar with the recommended operating and maintenance procedures and follows all the safety precautions. Most accidents can be prevented. Do not risk injury or death by ignoring good safety practices.

- Equipment owners must give operating instructions to operators or employees before allowing them to operate the machine, and at least annually thereafter per OSHA (Occupational Safety and Health Administration) regulation 1928.57.
- The most important safety device on this equipment is a **SAFE** operator. It is the operator's responsibility to read and understand **ALL** Safety and Operating instructions in the manual and to follow them. All accidents can be avoided.
- A person who has not read and understood all operating and safety instructions is not qualified to operate the machine. An untrained operator exposes himself and bystanders to possible serious injury or death.
- Do not modify the equipment in any way. Unauthorized modification may impair the function and/or safety and could affect the life of the equipment.
- Think SAFETY! Work SAFELY!

GENERAL SAFETY

1. Read and understand the operator's manual and all safety labels before operating, maintaining, adjusting or unplugging the equipment .
2. Only trained persons shall operate the equipment . An untrained operator is not qualified to operate the machine.
3. Have a first-aid kit available for use should the need arise, and know how to use it.



U-BATCH™ TREATER

4. Provide a fire extinguisher for use in case of an accident. Store in a highly visible place.
5. Do not allow children, spectators or bystanders within hazard area of machine.
6. Wear appropriate protective gear. This includes but is not limited to:
 - A hard hat
 - Protective shoes with slip resistant soles
 - Protective goggles
 - Heavy gloves
 - Hearing protection
 - Respirator or filter mask
7. Place all controls in neutral or off, stop motor, and wait for all moving parts to stop. Then disable power source before servicing, adjusting, repairing, or unplugging.
8. Review safety related items annually with all personnel who will be operating or maintaining the equipment.



OPERATING SAFETY:

1. Read and understand the operator's manual and all safety labels before using.
2. Disconnect and disable electrical supply completely and wait for all moving parts to stop before servicing, adjusting, repairing or unplugging.
3. Clear the area of bystanders, especially children, before starting.
4. Be familiar with the machine hazard area. If anyone enters hazard area, shut down machine immediately. Clear the area before restarting.
5. Keep hands, feet, hair and clothing away from all moving and/or rotating parts.
6. Stay away from overhead obstructions and power lines during operation and transporting. Electrocutation can occur without direct contact.
7. Do not operate machine when any guards are removed.
8. Inspect welds and repair if needed.

PLACEMENT SAFETY

1. Move only with the appropriate equipment
2. Stay away from overhead power lines when moving equipment. Electrocution can occur without direct contact.
3. Be familiar with machine hazard area. If anyone enters hazard areas, shut down machine immediately. Clear the area before restarting.
4. Operate the equipment on level ground free of debris. Anchor the equipment to prevent tipping or upending.



Before placement of the equipment , be sure that ground is reasonably level. The equipment may topple or work improperly if the ground is too uneven, damaging the equipment and/or causing personal injury.

MAINTENANCE SAFETY

1. Review the operator's manual and all safety items before working with, maintaining or operating the equipment .
2. Place all controls in neutral or off, stop motors, disable power source, and wait for all moving parts to stop before servicing, adjusting, repairing or unplugging.
3. Follow good shop practices:
Keep service area clean and dry.
Be sure electrical outlets and tools are properly grounded.
Use adequate light for the job at hand.
4. Keep hands, feet, hair and clothing away from all moving and/or rotating parts.
5. Clear the area of bystanders, especially children, when carrying out any maintenance and repairs or making any adjustments.
6. Before resuming work, install and secure all guards when maintenance work is completed.
7. Keep safety labels clean. Replace any sign that is damaged or not clearly visible.



SAFETY LABELS

1. Keep safety labels clean and legible at all times.
2. Replace safety labels that are missing or have become illegible.
3. Replaced parts that displayed a safety label should also display the current label.
4. Replacement safety labels are available. Contact USC at (785) 431-7900 .

How to Install Safety Labels:

- Be sure that the installation area is clean and dry.
- Be sure temperature is above 50°F (10°C).
- Decide on the exact position before you remove the backing paper.
- Remove the smallest portion of the split backing paper.
- Align the sign over the specified area and carefully press the small portion with the exposed sticky backing in place.
- Slowly peel back the remaining paper and carefully smooth the remaining portion of the sign in place.
- Small air pockets can be pierced with a pin and smoothed out using the piece of sign backing paper.

Think **SAFETY!** Work **SAFELY!**

REMEMBER—If safety labels have been damaged, removed, become illegible, or parts replaced without safety labels, new labels must be applied. New safety labels are available from USC at (785) 431-7900.



Part # 09-02-0002



U-BATCH™ TREATER



Part # 09-02-0003

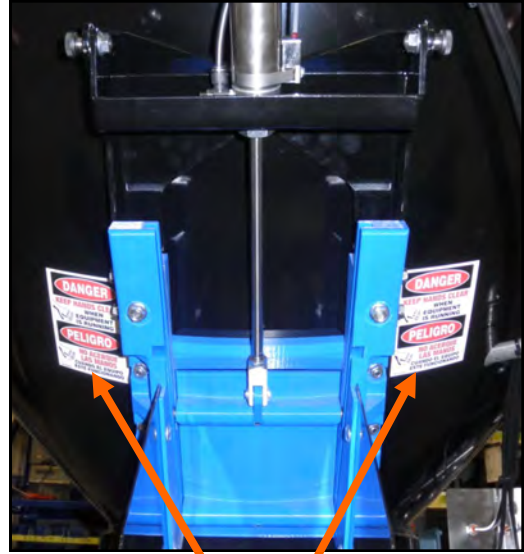

Part # 09-02-0001



U-BATCH™ TREATER

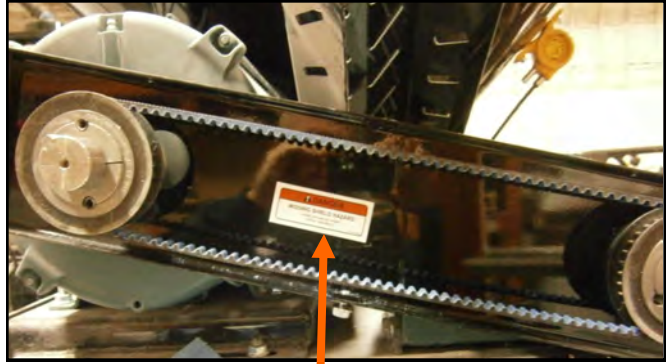
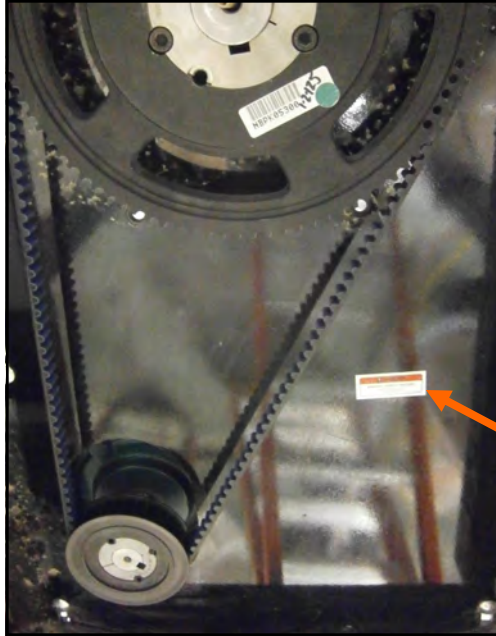

Part # 09-02-0012



Part # 09-02-0010



Part # 09-02-0009

SECTION
B**INSTALLATION**

HIGH VOLTAGE ~ Always disconnect the power source before working on or near the control panel or lead wires.



HIGH VOLTAGE ~ Use insulated tools when making adjustments while the controls are under power.

NOTICE

Permanent installation may require additional electrical cords, chemical tubing, and air lines, since each installation is unique.

SET-UP

The following steps outline the initial set-up of your U-Batch™ Treater :

1. Clear the area of bystanders, especially small children, before moving.
2. Be sure there is enough clearance from overhead obstructions and power lines or other equipment to move the machine into its working position.
3. Using a forklift, place the U-Batch™ Treater in the desired position on a level surface.

NOTICE

USC highly recommends that the U-Batch™ Treater be set up inside a building or any covered structure to protect the machine from weathering.

4. Inspect U-Batch™ Treater thoroughly for screws, bolts, fittings, etc. which may have come loose during shipping.
5. Positioning the treater with standard legs:

Use the forklift to raise the U-Batch™ Treater high enough so the legs may be installed. Attach the four horizontal legs (P\N 05-05-0123) to the base of the machine. Then, attach the four vertical legs (P\N 05-05-0122) to the horizontal legs (see page 112).

Lower the machine and place it in the final working position. Make sure there is ample room for a forklift to remove full pro boxes and replace them with empty ones. Place the inlet conveyor and ensure proper access to the pro box stand. Anchor the treater to the floor to prevent the machine from moving during operation.

SET-UP

6. Positioning the treater with hydraulic legs:

When the U-Batch™ Treater is ordered with the hydraulic lift option the treater and the legs are shipped already assembled.

Lower the machine and place it in the final working position. Make sure there is ample room for a forklift to remove full pro boxes and replace them with empty ones as well as lift a pro box over the inlet hopper.

NOTICE Do **NOT** anchor the U-Batch™ Treater to the floor until all connections for the lifting mechanism have been established and the treater is raised to the maximum height to verify ceiling clearance.

Place the hydraulic power supply in the desired location. The hydraulic fluid reservoir has been filled at the factory for testing. Place the unattached end of the hose track on the floor so that the ends are aligned (top). Attach the two hoses from the main assembly to the two hoses from the power supply (bottom).

After power is connected to the control panel, plug in the hydraulic motor power cable (see page 18, step 15) and the Raise / Lower control cable (see page 17, step 12) to the control panel. Raise and lower the treater to verify ceiling clearance. Anchor the treater, hydraulic assembly and the hose track to the floor to prevent the machine from moving during operation.





U-BATCH™ TREATER

SET-UP

- Have a certified electrician provide power to the U-Batch™ Treater system. Provide convenient shutdown switches, comply with local electrical codes and ensure that the system is properly grounded and bonded. All USC control panels must be connected adhering to the same electrical requirements as specified in the main control panel on the power requirement tag (right), or the electrical schematic shipped with the piece of equipment. This will power the U-Batch™ Treater.

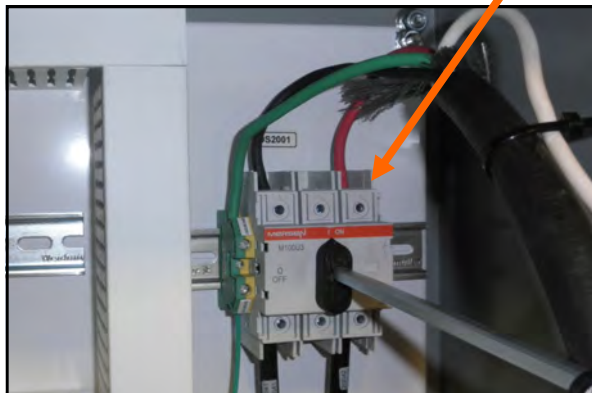
Incoming power connected to these terminals in the U-Batch™ Treater Control Panel





Mfg. By: USC, LLC
 Max voltage: 230V, 1PH, 60 HZ
 Total FLA: 84
 Largest Motor FLA: 50
 Schematic number: 03-12-0516A
 Enclosure rating: UL type 1
 Short Circuit Current Rating:
 5ka RMS Sym, 600V Max

WARNING
 To maintain over current, short-circuit and ground fault protection, the manufacturer's instruction for selection of overload and short circuit protection must be followed to reduce the risk of fire or electrical shock.

WARNING
 If an overload or a fault current interruption occurs, circuits must be checked to determine the cause of the interruption. If a fault condition exists, the current-carrying components should be examined and replaced if damaged, and the integral current sensors must be replaced to reduce the risk of fire or electrical shock.

AVERTISSEMENT
 Suivre les directives du fabricant pour protéger le système contre les surtensions, les courts-circuits et les défauts à la terre lors du choix des dispositifs de protection correspondants afin de réduire le risque d'incendie et de

AVERTISSEMENT
 En cas d'une interruption liée à une surtension ou à un courant de défaut, il convient d'inspecter les circuits afin d'identifier la cause de la panne. En cas de défaillance, les composantes qui transportent le courant doivent être examinées, puis remplacées si elles ont été endommagées, de même que remplacer les capteurs de courant intégral, afin de réduire le risque d'incendie et de décharge électrique.

Remplacement Fuse Chart			
Fuse	Line	Size	Type
FU2009	2009	4A	SB TL 150VDC
FU2009A	2009	4A	SB TL 150VDC
FU2206	2206	2A	FA FS
FU2301	2301	0.5A	FA FS
FU2511	2511	2A	T SB/TD GMD-2-
FU2512	2512	2A	T SB/TD GMD-2-
FU2519	2519	1A	FA FS

Quality Assurance
 Approved by: _____
 Mfg Date: _____



If you purchased a treater with a 3 Phase motor and have completed step 7, you need to verify that the motor is turning in the correct direction.

Remove the mixer motor drive belt guard and drive belt. Plug the power cable from the mix motor into the PJ2006 connector on the bottom of the control panel (see page 18, step 14).

Rotate the power switch on the control panel to the ON position. Once the HMI screen has booted up and the Click To Continue message is flashing (see page 25), touch anywhere on the screen and the main HMI screen appears. Press the Utilities button. From the Utilities screen, press the H-O-A button (see page 37). From the Mixer module at the top of the screen, press the HAND button to turn on the mixer motor. The mix motor drive pulley should be turning **CLOCKWISE**. If it is not, correct the incoming power. Replace the drive belt and set to the correct tension (see page 58). Then reinstall the drive guard

SET-UP

8. Attach the yellow connector on the end of this wire from PJ2305 to the black connector attached to the wire from the top sensor on the discharge slide gate Bimba cylinder.
9. Attach the yellow connector on the end of this wire from PJ2306 to the black connector attached to the wire connected to bottom sensor on the discharge slide gate Bimba cylinder.
10. Connect the two pin cable from Pump Stand to the PJ2012 pump motor connector.
11. Connect the four pin cable from the IFM volumetric flowmeter to the PJ2804 IFM / E&H FM COMM connector.
12. Connect the four pin cable from the Schneider relay TM3DQ8 on the hydraulic power assembly to the PJ2549 Raise / Lower solenoid connector. This will only be required if the treater was purchased with the hydraulic lift option.
13. If this installation is using more than one liquid pump stand, connect the cable from the pump stand motor you wish to be controlled by Auxiliary 1 button to the PJ2511 AUX PORT #1 connector and connect the cable from the pump stand motor you wish to be controlled by Auxiliary 2 button to the PJ2512 AUX PORT #2 connector.

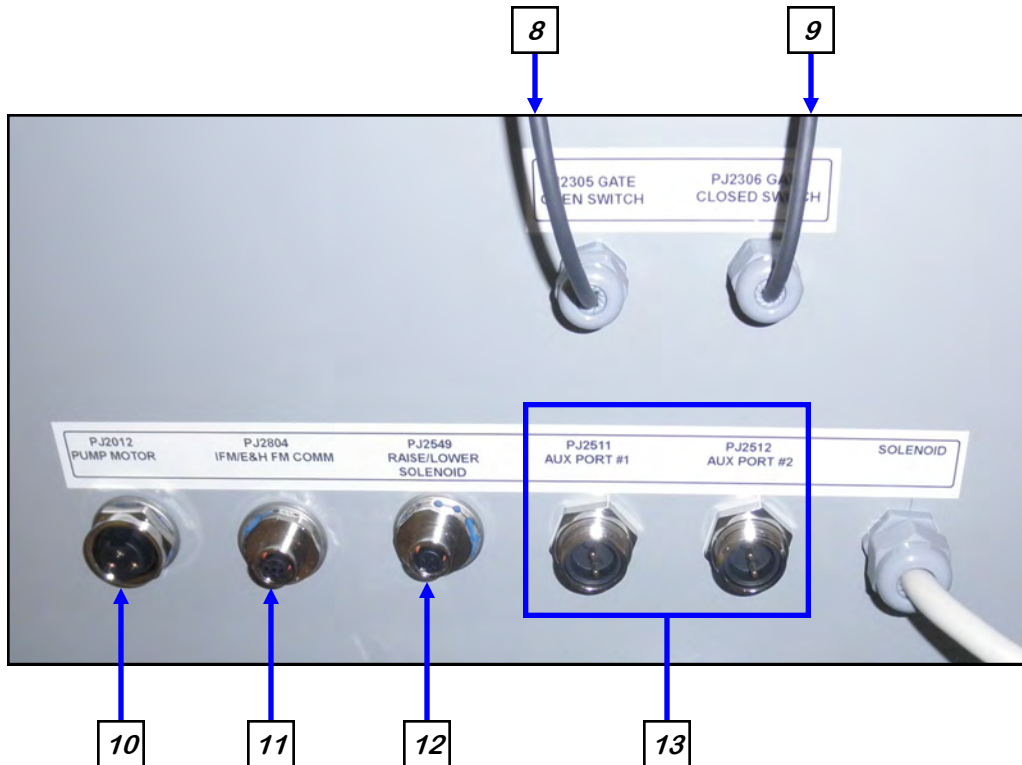

SET-UP

- 14. Attach the power cable from the mix motor to the PJ2006 Mixer connector.
- 15. Attach the power cable from the hydraulic lift motor to the PJ2016 Hydraulic Motor connector. This will only be required if the treater was purchased with the hydraulic lift option.

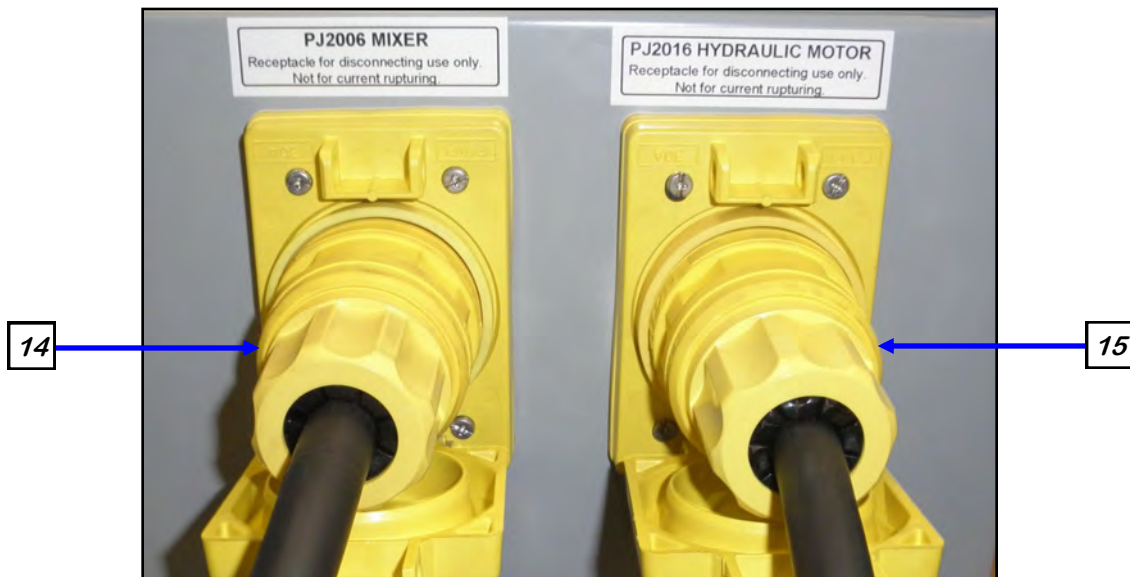

- 16. It is required that the air supply have an in-line customer supplied air dryer to protect the air system from contamination. Supply a constant flow at 4 SCFM of air with the capability of a 25 SCFM per minute for one to two minute bursts from the dryer, through a 1/2 inch line to the air regulator intake port located on the back of the pneumatic control assembly.

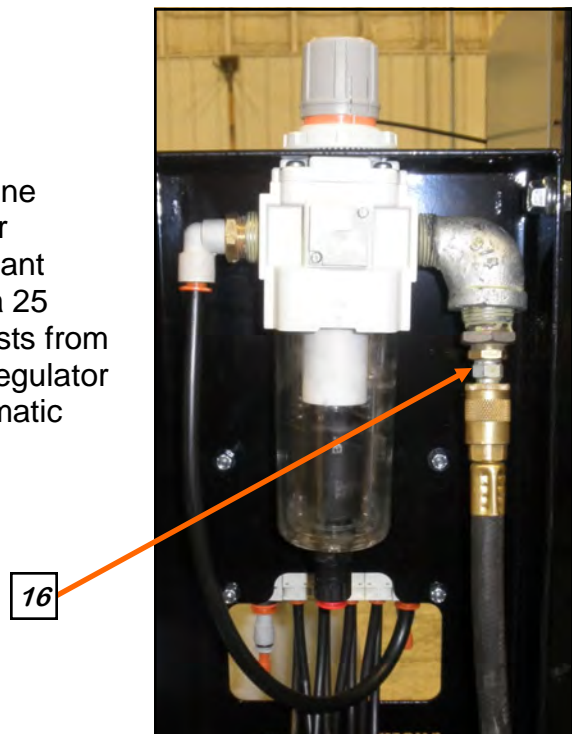

U-BATCH™ TREATER

SET-UP

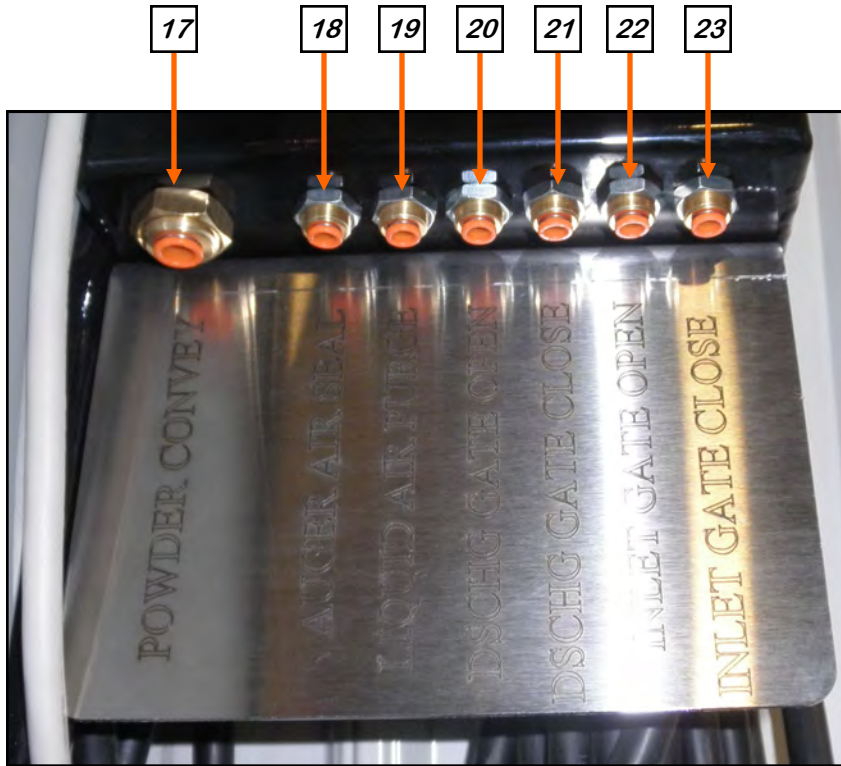

17. Run one 3/8 inch line from the Powder Convey fitting on the bottom of the pneumatic control assembly to the fitting on the discharge assembly at the bottom the powder unit.

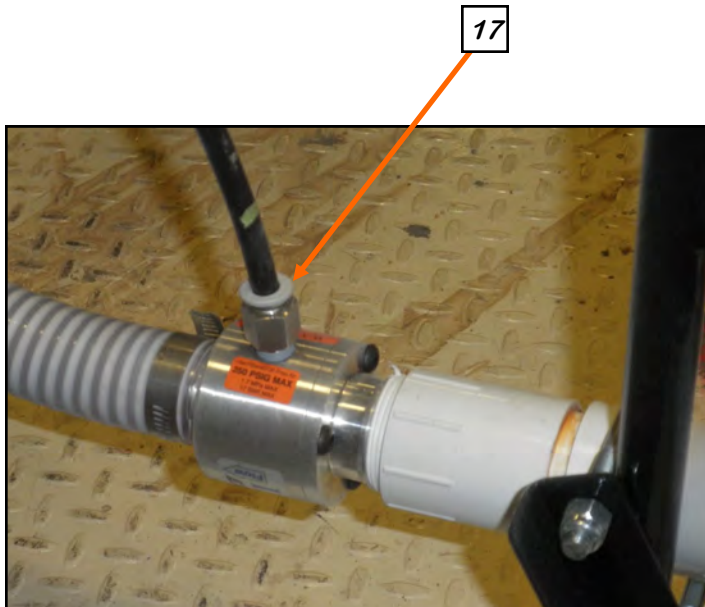

**POWDER
UNIT
DISCHARGE**

SET-UP

18. Run one 1/4 inch line from the AUGER AIR SEAL fitting on the bottom of the pneumatic control assembly to the AIR SEAL fitting on the air bulkhead plate.
19. Run one 1/4 inch line from the LIQUID AIR PURGE fitting on the bottom of the pneumatic control assembly to the LIQUID PURGE fitting on the air bulkhead plate.
20. Run one 1/4 inch line from the DSCHG GATE OPEN fitting on the bottom of the pneumatic control assembly to the DISCHARGE GATE OPEN fitting on the air bulkhead plate.
21. Run one 1/4 inch line from the DSCHG GATE CLOSE fitting on the bottom of the pneumatic control assembly to the DISCHARGE GATE CLOSE fitting on the air bulkhead plate.
22. Run one 1/4 inch line from the INLET GATE OPEN fitting on the bottom of the pneumatic control assembly to the INLET GATE OPEN fitting on the air bulkhead plate.
23. Run one 1/4 inch line from the INLET GATE CLOSE fitting on the bottom of the pneumatic control assembly to the INLET GATE CLOSE fitting on the air bulkhead plate.

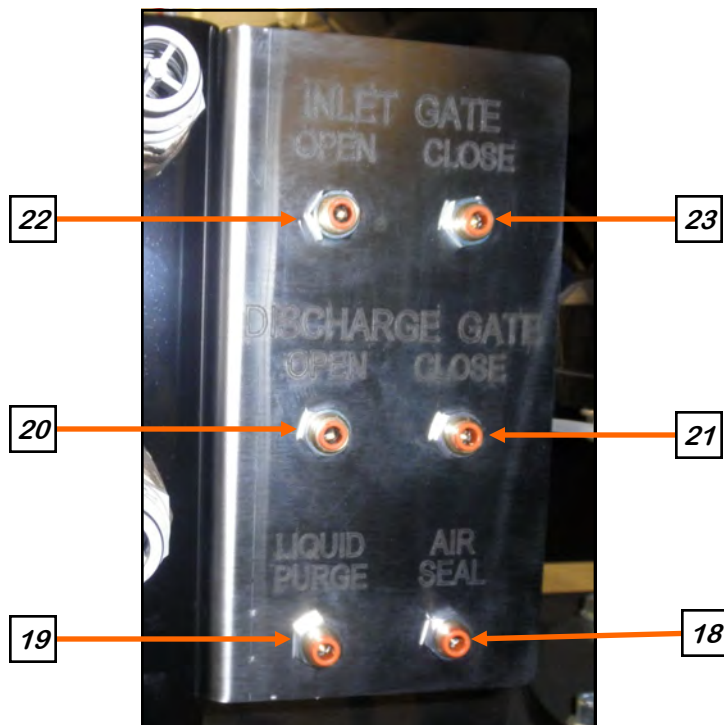

MECHANICAL OPERATION

U-BATCH™ TREATER OVERVIEW

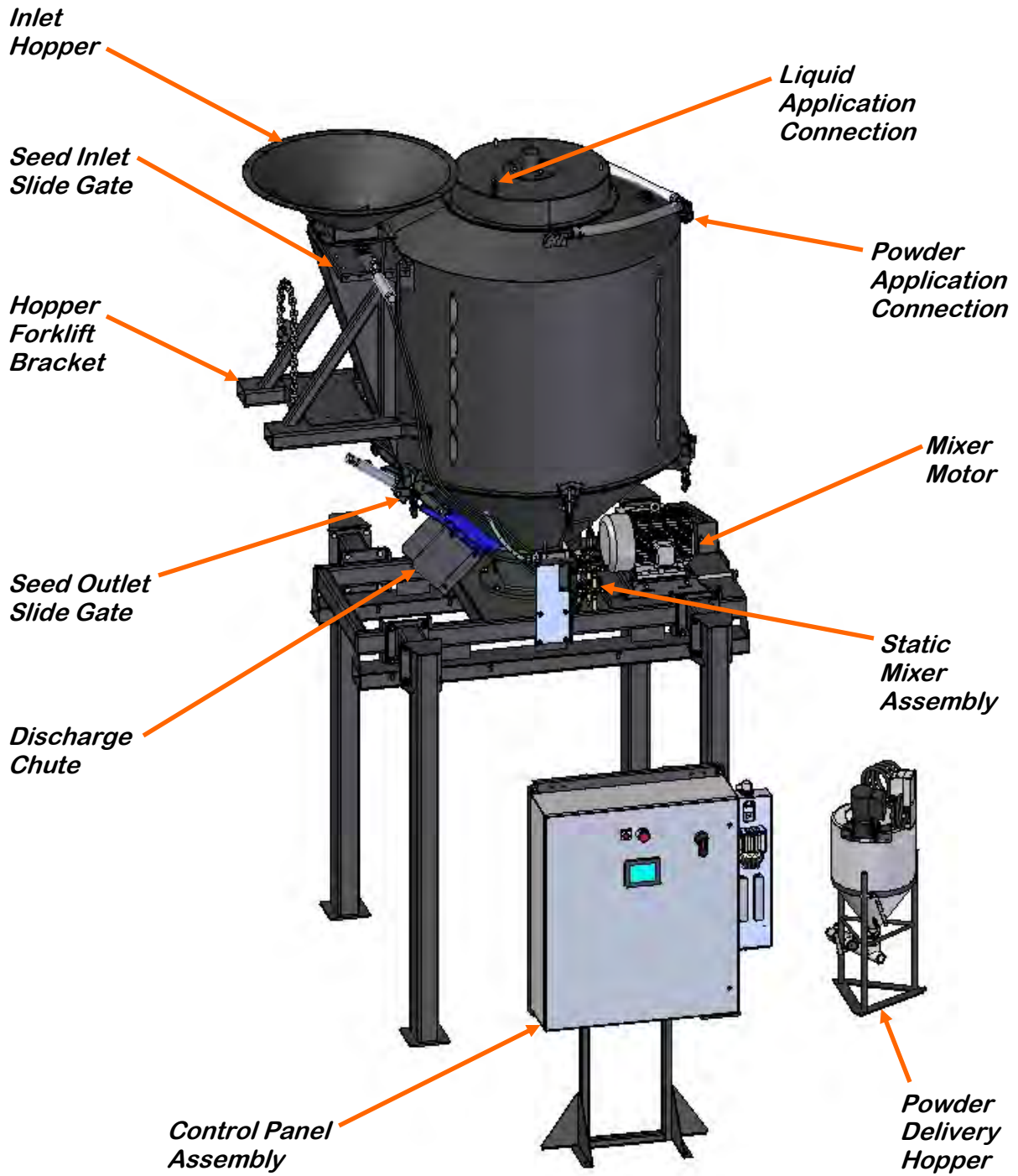

U-BATCH™ HYDRAULIC LIFT OVERVIEW

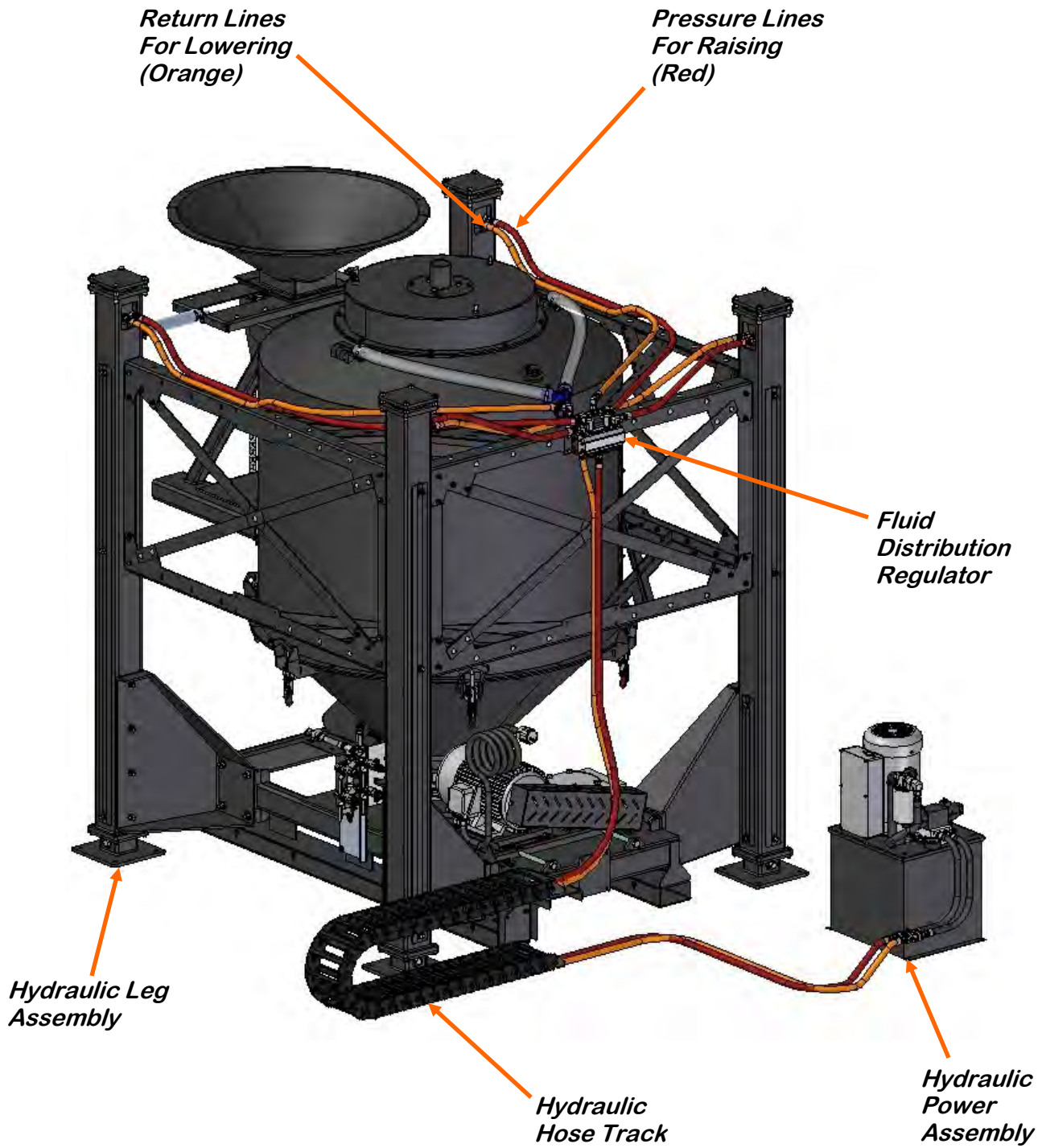

CONTROL PANEL ASSEMBLY OVERVIEW

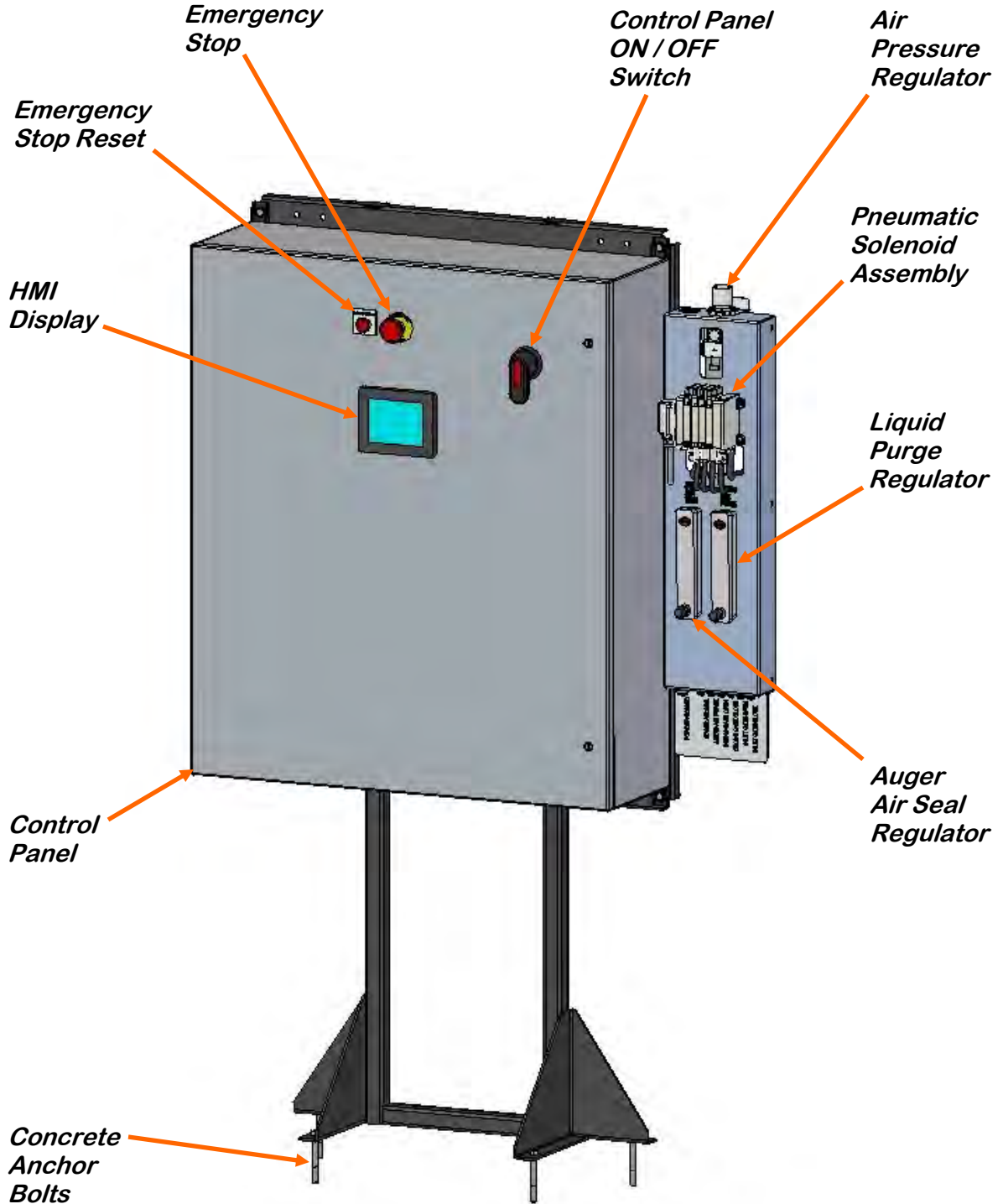

SECTION
D

ELECTRICAL OPERATION



HIGH VOLTAGE ~ Always disconnect the power source before working on or near the control panel or lead wires.



HIGH VOLTAGE ~ Use insulated tools when making adjustments while the controls are under power.



AUTHORIZED PERSONNEL only shall work on the control panel. Never allow anyone who has not read and familiarized themselves with the owner's manual to open or work on the control panel.

This section provides a general overview and description of the operator controls for the U-Batch™ Treater.



USC recommends the use of a surge protection device with a minimum rating of 400 Joules for all automated main control panels.



The E-Stop Reset push button must be pressed after every power cycle and every time the E-Stop is activated or the system will not operate.

General Panel Descriptions

- The U-Batch™ Treater control panel is a 30 x 24 x10 inch enclosure that contains all of the electrical control components as well as the HMI (Human/Machine Interface) touch screen. The operator is able to control the entire system through the HMI.

USC STARTUP SCREEN

NOTICE

Some of the screens have a round blue button with a question mark in the upper left corner of the screen. Selecting this button will bring up a help screen covering the functions of that screen.

While the system is booting up, the touch screen will display a timer bar at the bottom of the Start Up Screen. Once the timer bar reaches the end it will disappear and be replaced with flashing line of text that reads **CLICK TO CONTINUE**. Select any where on the screen and it will advance to the Main screen.

This screen also displays the version of the software currently installed.



MAIN SCREEN

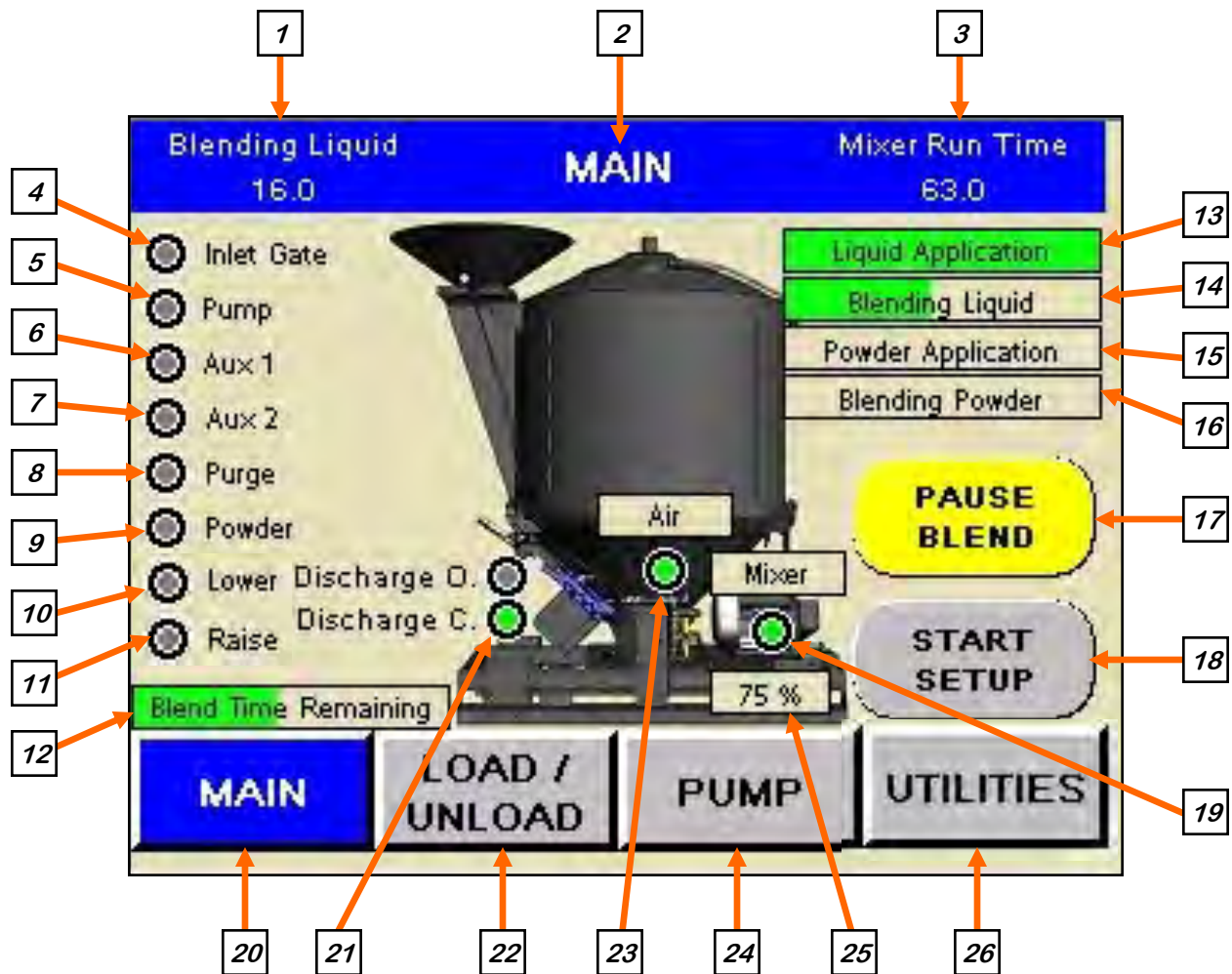

1. STATUS DISPLAY: Displays the current process status of the system. If system is not in operation it will read **Idle**, when a run has been initiated, it will read **Starting Mix Motor**. When the motor has reached operating speed it will walk through the process, **Processing Liquid**, **Blend Liquid**, **Processing Powder** and **Blend Powder**, etc.

2. SCREEN TITLE DISPLAY: Displays the current screen the operator is viewing.

3. MIXER RUN TIME: This indicator will display the amount of time in seconds from the beginning of a run until it is complete.

MAIN SCREEN

NOTICE

When the indicators on items 4 - 11, 19, 21 and 23 have a square yellow border around the green indicator, they are operating in HAND mode. HAND mode is the manual mode of operation.

4. INLET GATE: This indicator will be green when the gate is being moved from open to closed or closed to open.

5. PUMP: This indicator turns green when the pump motor on the liquid pump stand is running.

6. AUX 1: This indicator turns green when the pump motor on the second liquid pump stand is running if one is attached to the system.

7. AUX 2: This indicator turns green when the pump motor on the third liquid pump stand is running if one is attached to the system.

8. PURGE: This indicator turns green when the solenoid opens the pneumatic valve starting the flow of compressed air to the supply line on the top of the static mixer. This will clear the supply line from the static mixer assembly to the supply ring located in the bottom of the treating hopper. This function is controlled on the Pumps H-O-A screen (see page 38).

9. POWDER: This indicator turns green when the solenoid opens the pneumatic valve starting the flow of compressed air to move the powder from the dry applicator stand to the top of the treater. This function is controlled on the Pumps H-O-A screen (see page 38).

10. LOWER: This indicator turns green when the pump motor on the hydraulic treater lift frame is lowering the treater. This indicator will only be present if the hydraulic lift option is on the treater.

11. RAISE: This indicator turns green when the pump motor on the hydraulic treater lift frame is raising the treater. This indicator will only be present if the hydraulic lift option is on the treater.

NOTICE

The indicators on items 12 - 16, display a green bar that starts on the left and progresses to the right showing the elapsed time of the process that has been completed.

MAIN SCREEN

12. BLEND TIME REMAINING: This indicator displays the progress of the entire batch run from start to finish. The Mixer run time in the upper right hand corner of the screen will show that time in seconds.

13. LIQUID APPLICATION: This indicator displays the progress of the liquid pump stand delivering the pre-defined amount of treatment to the hopper and the purging of the supply line.

14. BLENDING LIQUID: This indicator displays the progress of the timed mixing process after all of the liquid has been applied.

15. POWDER APPLICATION: This indicator displays the progress of the powder applicator delivering the pre-defined amount of dry material to the hopper.

16. BLENDING POWDER: This indicator displays the progress of the timed mixing process after all of the dry material has been applied.

17. PAUSE BLEND: When a batch is in process this indicator is appears. The operator may manually press this button at any time during the run to stop the process. It will also appear when a system fault has occurred.

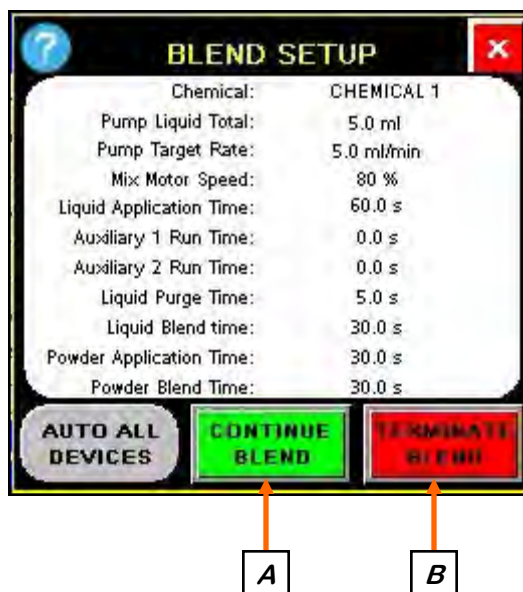

17A. PAUSE BLEND: If the system was paused manually, pressing this button and holding it for two seconds will restart the run from where it was stopped. If the system was stopped automatically. The system fault will need to be resolved, then press Continue Blend to restart.

MAIN SCREEN

17B. PAUSE BLEND: Pressing this button and holding it for two seconds will terminate the blending run.

18. START SETUP: Pressing this button brings up the Blend Setup popup screen.

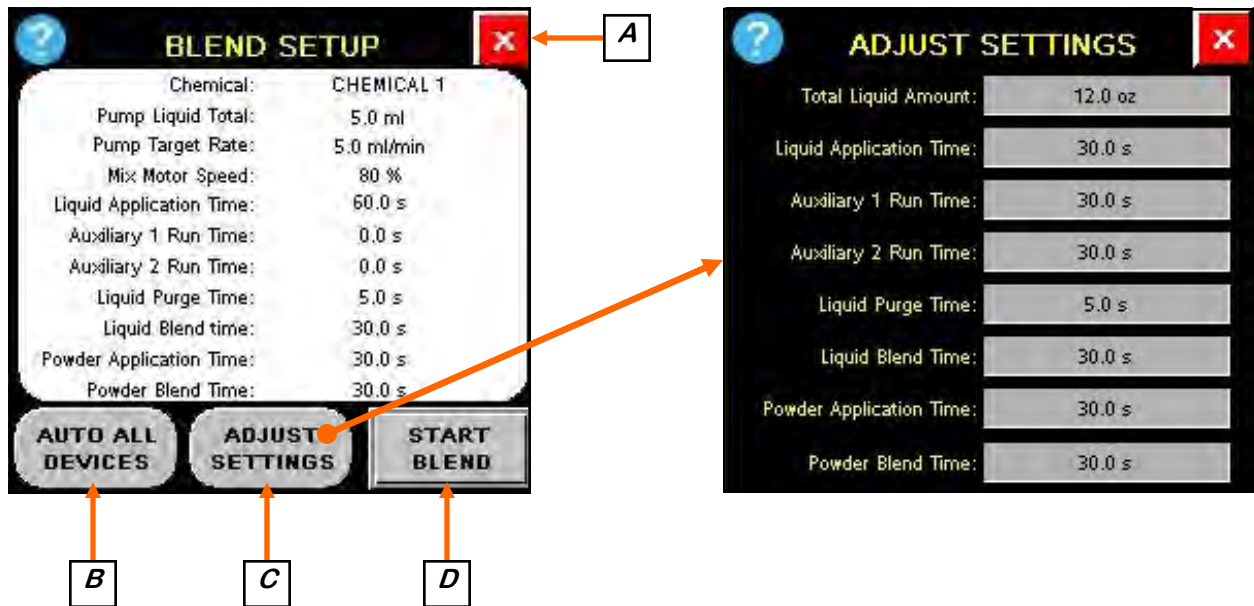

18A. EXIT: This button is used to close the popup screen. It has the same functionality throughout the HMI display.

18B. AUTO ALL DEVICES: When this button is pushed, it globally changes all HOA settings to the AUTO mode of operation. When it is yellow, it indicates a device is in the Hand mode of operation and is not set to Auto.

18C. ADJUST SETTINGS: Pressing this button brings up the Adjust Settings popup screen.

18D. START BLEND: Pressing this button and holding it for two seconds begins the blend process. The system will run automatically until the blend is complete.

19. MIXER: When this indicator is active, the mixer motor is running.

20. MAIN: This button returns the operator to the main screen (see page 26).

MAIN SCREEN

21. DISCHARGE: When one of these indicators is active, the discharge gate will be in the open or closed position.

22. LOAD / UNLOAD: This button advances the operator to the Load / Unload screen (see page 31).

23. AIR: When this indicator is active, compressed air is supplying pressure securing the seal at the bottom of the hopper.

24. PUMP: This button advances the operator to the Pump screen (see page 30).

25. MOTOR PERCENTAGE: This indicator displays what percentage of maximum power the motor is running at.

26. UTILITIES: This button advances the operator to the Utilities screen. (see page 37).

LOAD / UNLOAD SCREEN

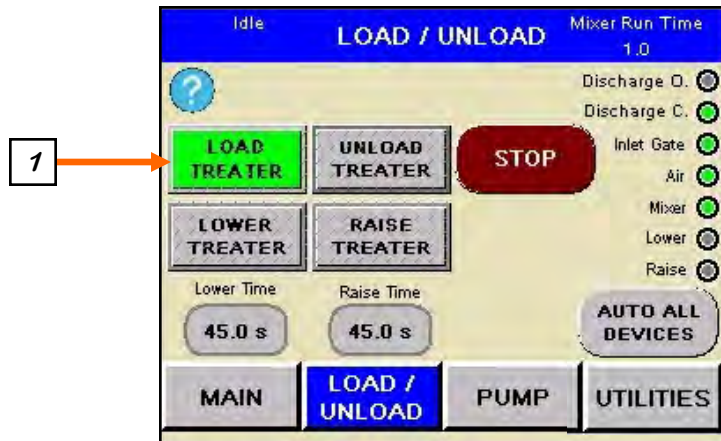

1. LOAD OR UNLOAD TREATER: Press the Lower Treater button and hold for two seconds and the Inlet gate will open, the discharge gate will close, the air seal will pressurize and the mix motor will start. This process will run until the operator presses the stop button that appears after it is started. This works the same when unloading the treater except the discharge gate will be in the open position.

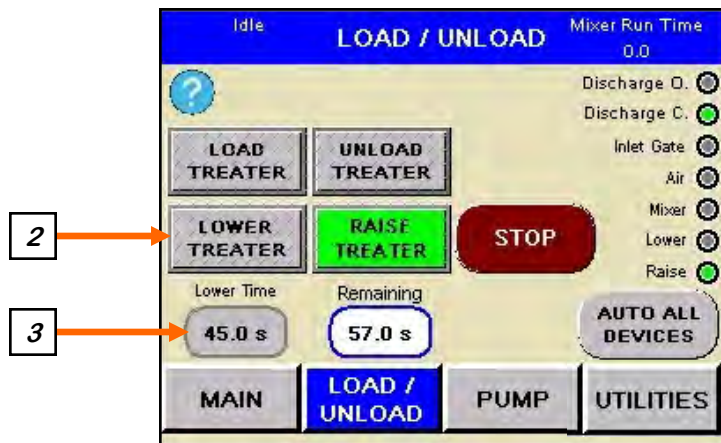

2. LOWER OR RAISE TREATER: Press the Raise Treater button and hold for two seconds, the discharge gate will close and the raise indicator will show that the hydraulic motor is operating. This process will run until the pre-determined time has elapsed stopping the motor. This works the same when unloading the treater except the motor runs in reverse.

3. LOWER OR RAISE TIME: The treater will raise and lower to a fixed high and low position. Press these buttons to set the amount of time for the treater to travel the fixed distance. When the process has started, the button becomes an indicator counting down the number of seconds left to completion.

PUMP SCREEN

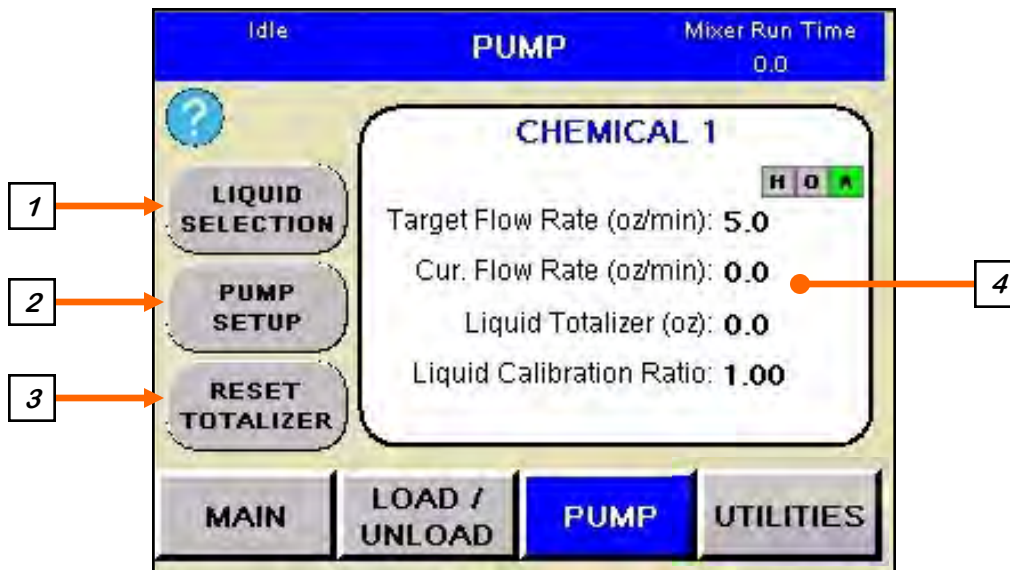

1. LIQUID SELECTION: Pressing this button brings up the Liquid Product Selection or Editing popup screen (see page 33).

2. PUMP SETUP: Pressing this button advances the operator to the flow rate setup screens (see page 36).

3. RESET TOTALIZER: Pressing this button will reset the liquid totalizer display after a run is complete.

4. CHEMICAL STATUS BOX: Displays the name of the active chemical at the top, as well as the target flow rate and the current flow rate. The liquid totalizer displays the amount of chemical used and the liquid calibration ratio for the chemical being used. The H-O-A display in the upper right corner informs the operator of the current motor status without having to press the H-O-A button leaving the main screen.

PUMP SCREEN

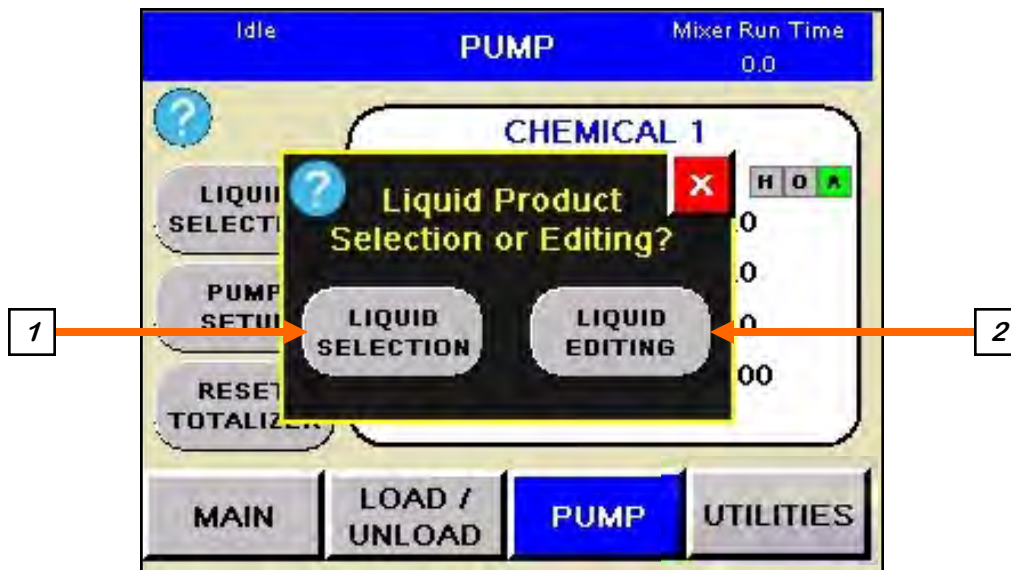

1. LIQUID SELECTION: Pressing this button advances the operator to the Liquid Selection screen (bottom, left). Use the arrows to scroll through the list to find the chemical you wish to use. The system can store up to 100 different chemical entries. Each chemical type will have its own name and calibration ratio. Selecting an existing chemical will return you to the main screen.

2. LIQUID EDITING: Pressing this button advances the operator to the Liquid Editing screen (bottom, right). Select a chemical from the list to modify or an unused box to create a new chemical entry. The Liquid Editing screen will appear (see page 34).

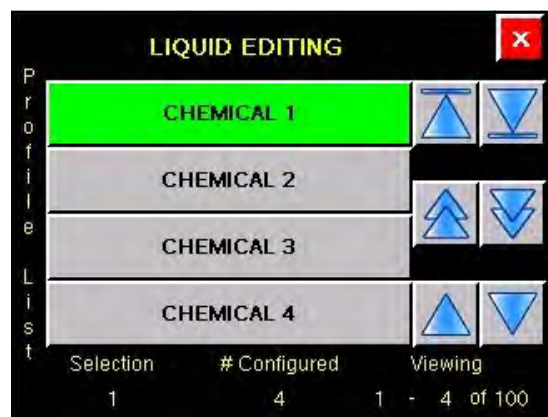
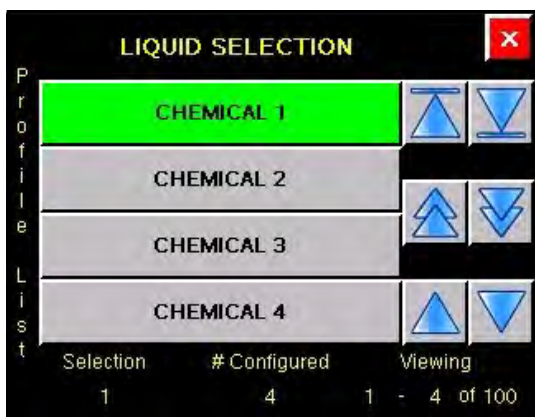

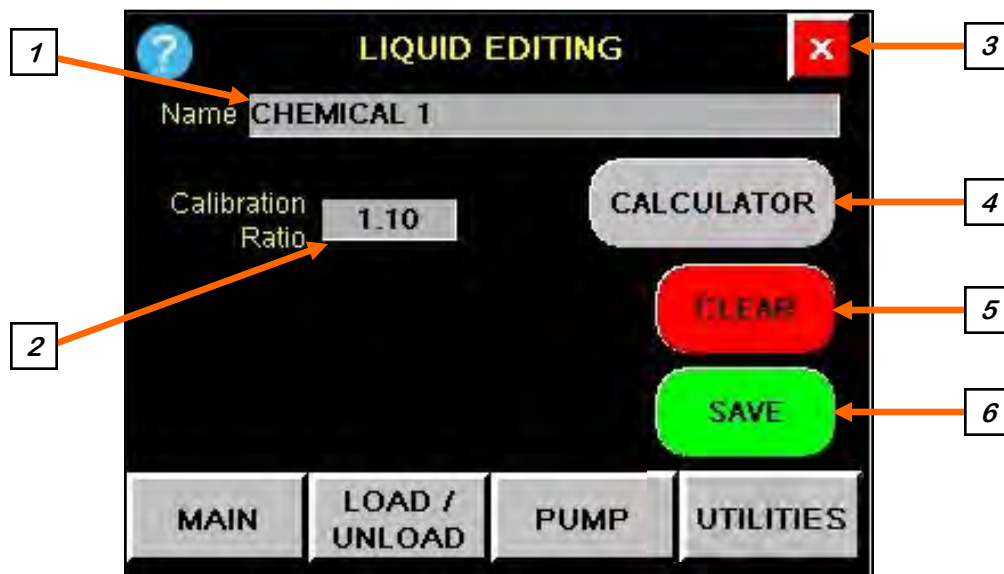
PUMP SCREEN

1. LIQUID NAME: When this button is pushed an alpha numeric keypad appears allowing the operator to change an existing chemical name. If an unused box was selected from the list, the Name will be blank and the Calibration Ratio will be 1.0, allowing the operator to enter a new chemical into the system. Once saved, it will be added to the list.

2. CALIBRATION RATIO: When this button is pushed a numeric keypad appears allowing the operator to manually enter the multiplier used for flow meter calibration.

3. SCREEN EXIT: This button is used to return to the previous screen. It's functionality is the same throughout all of the HMI screens.

4. CALCULATOR: Pressing this button takes the operator to the Calibration Calculator screen (see page 35).

5. CLEAR: This button deletes the name and resets the Calibration Factor to 1.00. After a new name and calibration factor has been entered, press the save button. This is another way to enter a new chemical name in the system.

6. SAVE: Saves any changes to the chemical profile.

PUMP SCREEN

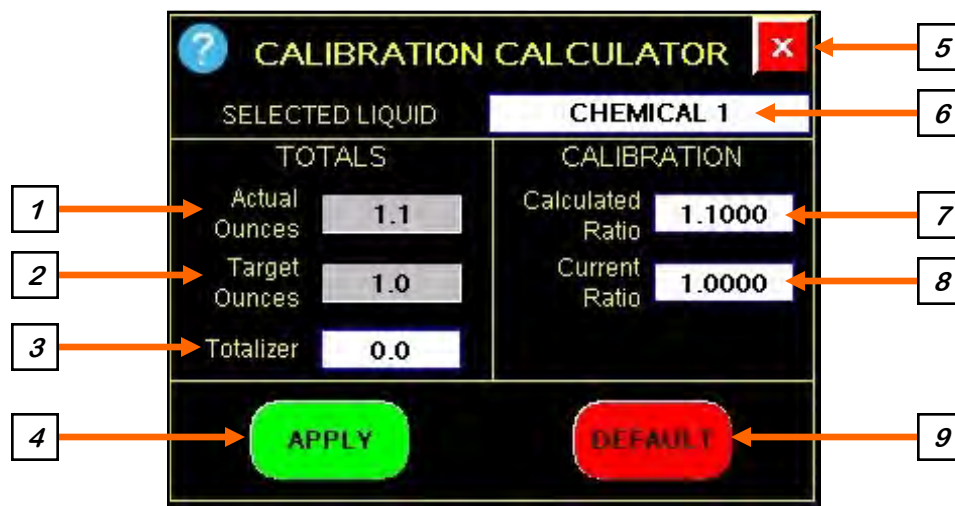

1. ACTUAL OUNCES: Pressing this button brings up a keypad used to enter the actual ounces applied during the calibration procedure.

2. TOTALIZER OUNCES: Pressing this button brings up a keypad used to enter the amount of ounces the system should have been applied.

3. TOTALIZER: This display indicates the amount of chemical the program estimates it applied on the last run.

4. APPLY: After the actual ounces and totalizer ounces have been entered, the calculated ratio will be updated. Pressing this button returns the operator to the liquid editing screen and updates the calibration ratio.

5. SCREEN EXIT: Pressing this button returns the operator to the recipe editing screen. It's functionality is the same throughout all of the HMI screens.

6. SELECTED LIQUID: This display indicates the name of the chemical for this calibration.

7. CALCULATED RATIO: This display indicates the amount the current calibration will be adjusted when the apply button is pressed.

8. CURRENT RATIO: This display indicates the current calibration.

9. DEFAULT: Pressing this button returns all values to the default setting of one.

NOTICE

The actual ounces will always be the amount caught by either a calibration tube or other measuring device. The target ounces are the amount that should have been caught in the measuring device. The operator may use the amount they physically measured, or the totalizer amount. The totalizer amount is the programs estimation of what the measuring device should have received.

PUMP SETUP SCREENS

MODE: Off - Allows the operator to define the pump speed in two ways. One is by checking the Target Rate box and entering the ounces to apply per minute. The other is to check the Pump Percentage box and key in the percent of full motor speed. If the treater is running in Batch mode, define the batch application time in seconds as well as the compressed air supply line purge.

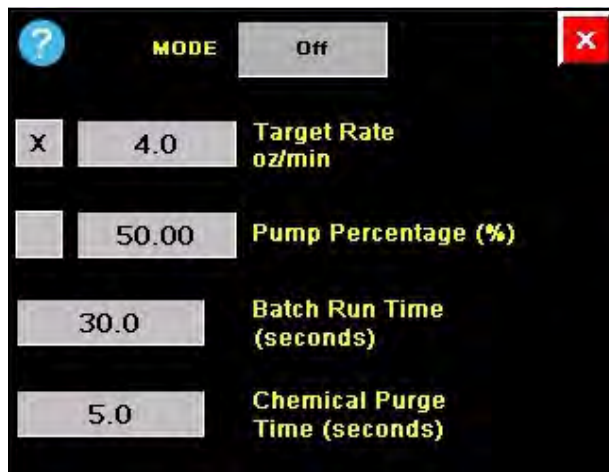

MODE: Direct Translation – Allows the operator to set pump in oz / min. The flow rate will be maintained using the output from the flow meter.



MODE: Batch Translation – Allows the operator to set pump flow rate by total ounces per batch. Enter the total amount to be used in the Pump 1 box. Enter the total run time for the batch and the system will calculate the ounces per minute required.

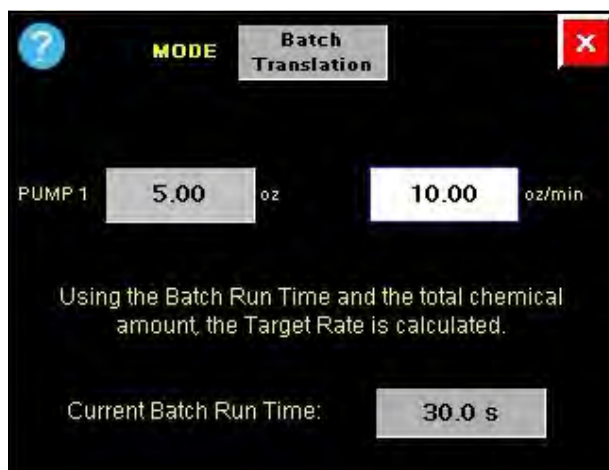

UTILITIES SCREEN



1. H-O-A: Pressing this button advances the operator to the Treater, Pumps, Auxiliary and Slide Gate screens (see page 38).

2. TOOLS & OPTIONS: Pressing this button advances the operator to the Tools and Options screen (see page 43).

3. SECURITY: Pressing this button advances the operator to the Security screen (see page 44).

4. SETPOINTS: Pressing this button advances the operator to the Setpoints screen (see page 45).

5. ALARMS: Pressing this button advances the operator to the Alarms screen. (see page 50).

6. USC LOGO: Pressing this button returns the operator to the Startup screen (see page 25).

H-O-A TREATER SCREEN

⚠ WARNING



The buttons on the HOA screens force the selected component to be energized or de-energized. **Be sure to understand the impact of energizing or de-energizing a component before using them. These commands are not a substitute for lockout procedures when working on or near this machine. Use proper lockout procedures to disable the equipment before servicing it.**

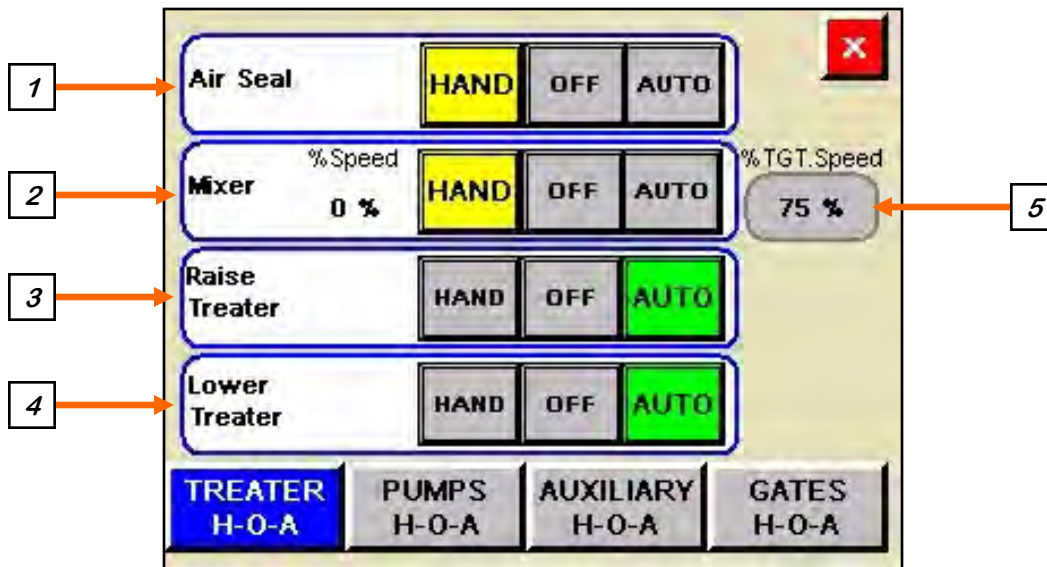

1. AIR SEAL CONTROL MODULE: This module controls the function of the air seal at the bottom of the mixing hopper. The HAND button will place the air seal in the manual mode of operation. The OFF button will turn the associated device in the OFF mode of operation. The AUTO button will place the device in the automatic mode of operation. The air seal will not seat against the hopper in this function unless all other needed devices are in the AUTO mode and the Start Blend button is pressed on the Blend Setup screen.

H-O-A TREATER SCREEN

2. MIXER CONTROL MODULE: This module controls the function of the mixing auger motor. The HAND button will place the auger in the manual mode of operation. The OFF button will turn the associated device in the OFF mode of operation. The AUTO button will place the device in the automatic mode of operation. The motor will not operate in this function unless all other needed devices are in the AUTO mode and the Start Blend button is pressed on the Blend Setup screen.

3. RAISE TREATER CONTROL MODULE: This module controls the function of the treater hydraulic lift motor. The HAND button will place the motor in the manual mode of operation. The OFF button will turn the associated device in the OFF mode of operation. The AUTO button will enable the Raise Treater button on the Load / Unload screen. This module will only be present if the hydraulic lift option is on the treater.

4. LOWER TREATER CONTROL MODULE: This module controls the function of the treater hydraulic lift motor. The HAND button will place the motor in the manual mode of operation. The OFF button will turn the associated device in the OFF mode of operation. The AUTO button will enable the Lower Treater button on the Load / Unload screen. This module will only be present if the hydraulic lift option is on the treater.

5. MIX MOTOR PERCENT SPEED: When this button is pressed, a numeric touch pad will appear to allow the operator to adjust the speed of the mix motor. It drives the motor to a specified percentage of the maximum mix speed. This value may be changed while the mix motor is running.

H-O-A PUMPS SCREEN

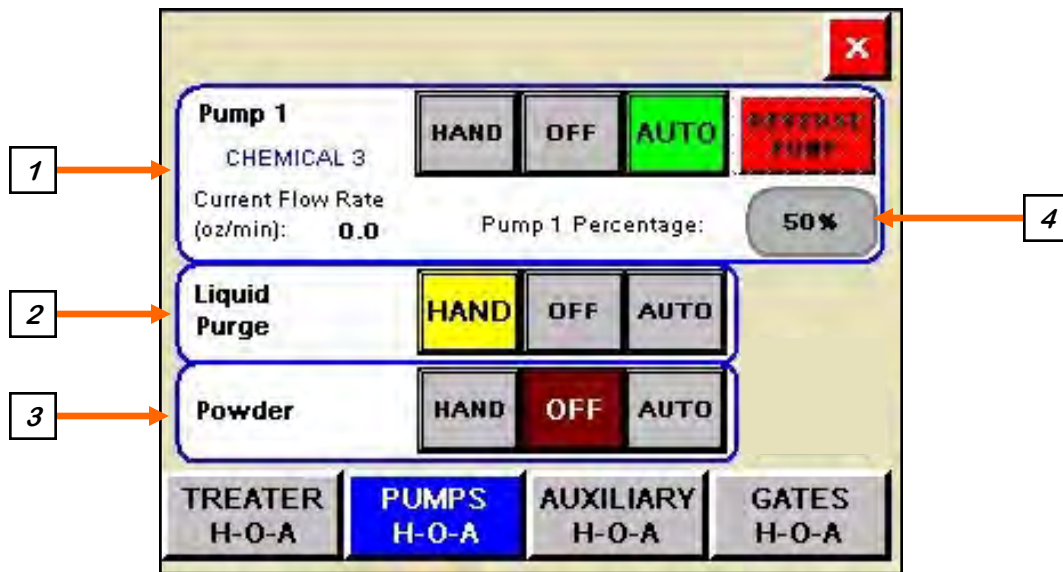

1. PUMP 1 H-O-A MODULE: This module controls the function of the liquid pump motor. The HAND button will place the pump motor on in the manual mode of operation. When it is active it will turn yellow. The OFF button will turn the motor off in the manual mode of operation. When it is active it will turn red. The AUTO button will place the device in the automatic mode of operation. When it is active it will turn green. Pressing the REVERSE PUMP button will place the pump in HAND mode but the pump will be running backwards.

2. LIQUID PURGE MODULE: This module controls the function of solenoid for the compressed air used to clean the supply line. The HAND button will place the solenoid in the manual mode of operation. When it is active it will turn yellow. The OFF button will switch the solenoid to the closed position. When it is active it will turn red. The AUTO button will place the device in the automatic mode of operation. When it is active it will turn green.

3. POWDER : Press the Run Time button and use the numeric keypad to enter the number of seconds for the air to run while delivering powder from the hopper to the top of the mix hopper. Pressing the START button engages the solenoid to begin air flow to the supply line of the powder delivery hopper.

4. PUMP MOTOR PERCENT SPEED: When this button is pressed, a numeric touch pad will appear to allow the operator to adjust the speed of the liquid mix motor. It drives the motor to a specified percentage of the maximum pump speed.

U-BATCH™ TREATER
H-O-A AUXILIARY SCREEN

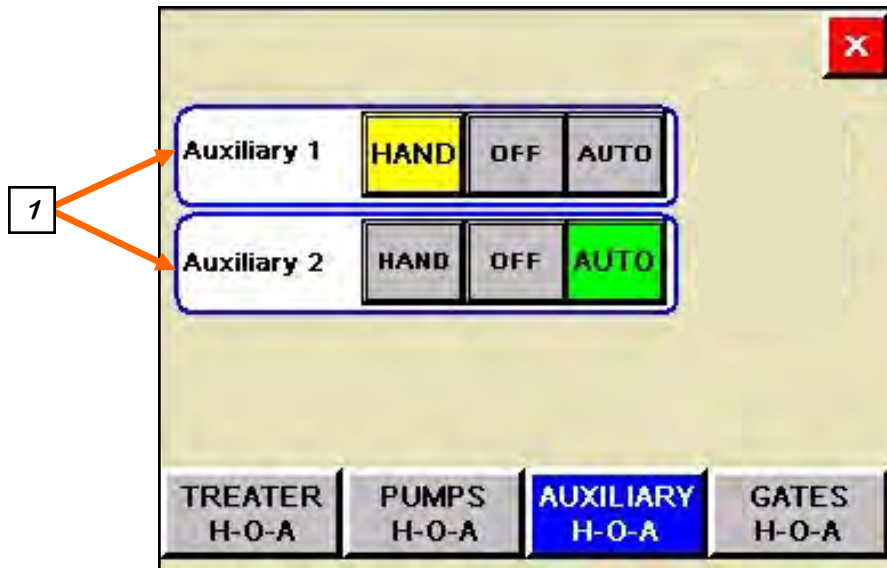

1. AUXILIARY 1 & 2 H-O-A MODULE: These modules control the function of the auxiliary liquid pump motors. The HAND button will place the pump motor on in the manual mode of operation. When it is active it will turn yellow. The OFF button will turn the motor off in the manual mode of operation. When it is active it will turn red. The AUTO button will place the device in the automatic mode of operation. When it is active it will turn green.

U-BATCH™ TREATER
H-O-A GATES SCREEN

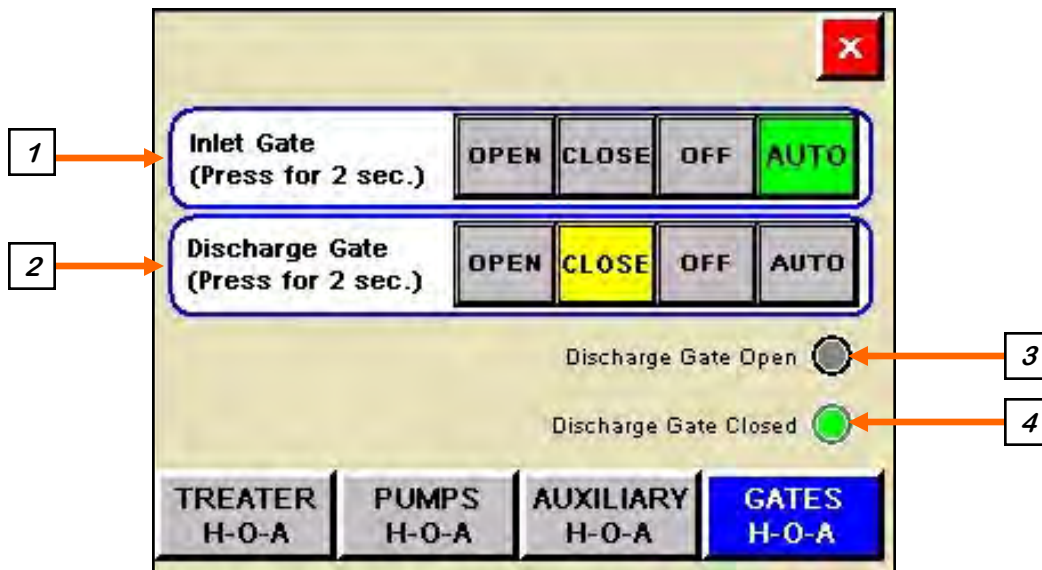

1. INLET GATE CONTROL MODULE: This module controls the function of the inlet slide gate. To manually open the gate you must press and hold the OPEN button for two seconds. To manually close the gate you must press and hold the CLOSE button for two seconds. The OFF button will disable the gate regardless of which position it is in. The gate must be in AUTO mode for it to automatically open and close at the appropriate time during a batch run.

2. DISCHARGE GATE CONTROL MODULE: This module controls the function of the inlet discharge gate. To manually open the gate you must press and hold the OPEN button for two seconds. To manually close the gate you must press and hold the CLOSE button for two seconds. The OFF button will disable the gate regardless of which position it is in. The gate must be in AUTO mode for it to automatically open and close at the appropriate time during a batch run.

3. DISCHARGE GATE OPEN: This indicator turns green when the gate is in the open position.

4. DISCHARGE GATE CLOSED: This indicator turns green when the gate is in the closed position.

U-BATCH™ TREATER
TOOLS & OPTIONS SCREEN



1. SET DATE AND TIME: Pressing this button advances the operator to the Date and Time screen. From here, they may change the date or exact time. After the new information has been entered in their respective boxes, press the Set Date & Time button.



2. UNIT OF MEASURE: Pressing this button toggles between Standard or Metric units of measurement.

3. AIR SEAL ENABLED FOR PAUSE STATE: Pressing this button toggles between activating or de-activating the air seal when the system is paused.

SECURITY SCREEN

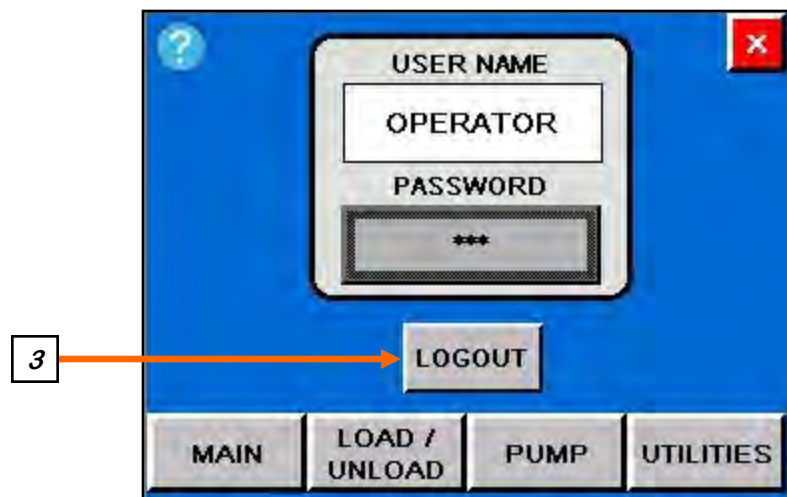
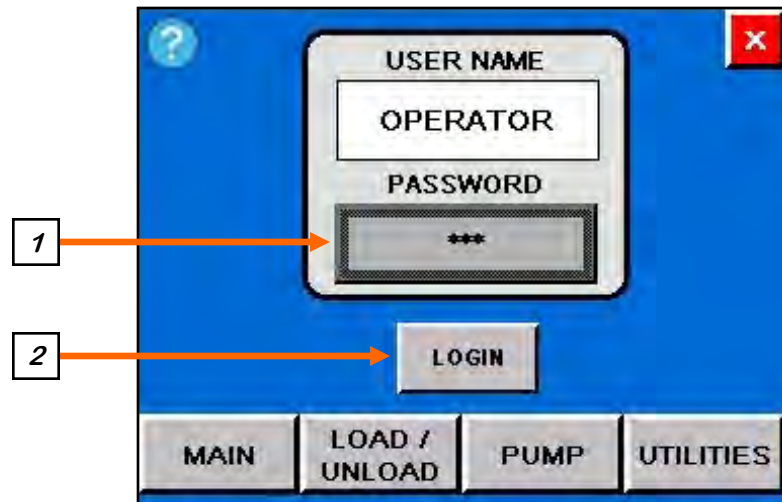

1. PASSWORD ENTRY: The operator uses this input to obtain access to the Setpoints screen from the button on the Utilities screen (see page 37). When this button is pressed an alpha numeric keypad will appear. The password is **USC** and should only be made accessible to personnel qualified to operate the system.

2. LOGIN: Pressing this button after the password has been entered will activate the SETPOINTS button.

3. LOGOUT: Pressing this button will de-activate the Setpoints button on the Utilities screen.

U-BATCH™ TREATER
SETPOINTS 1 SCREENS

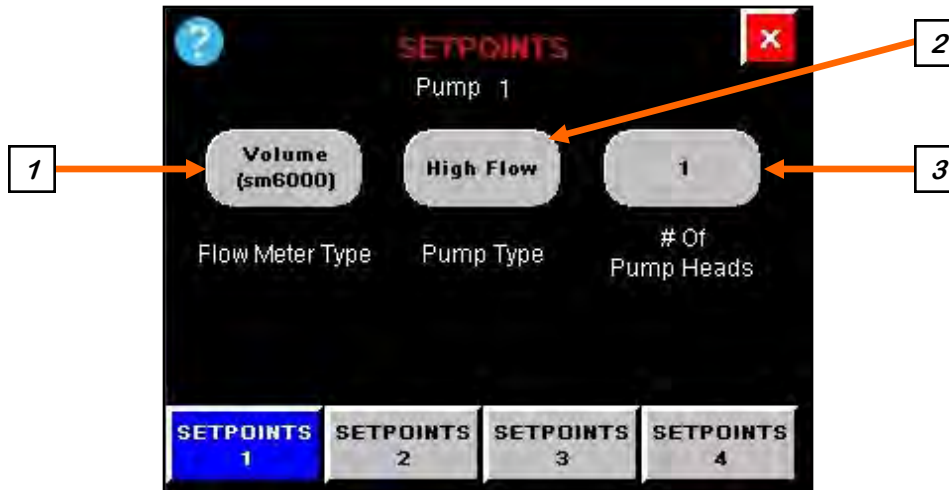

1. FLOW METER TYPE: Pressing this button toggles between Volumetric, Mass and Custom flow meter options to match the type of flow meter being used with your equipment. If using a Non-USC type pump, it would be set to custom activating the Custom PID Settings button (see page 46).

2. PUMP TYPE: Pressing this button toggles between Low Flow, Base Flow and High Flow. The low flow setting is configured for the low flow peristaltic pump assembly. The base setting is configured for one of the three standard pump configurations. When set to base flow, the # of pumps heads button must be set to either 1, 2 or 3 to match the number standard peristaltic pump heads installed. The high flow setting is configured for the high flow peristaltic pump assembly.

3. # OF PUMP HEADS: Pressing this button toggles between 0, 1, 2 and 3 to be set to the number of peristaltic pump heads are on the pump stand.

U-BATCH™ TREATER
SETPOINTS 1 SCREENS

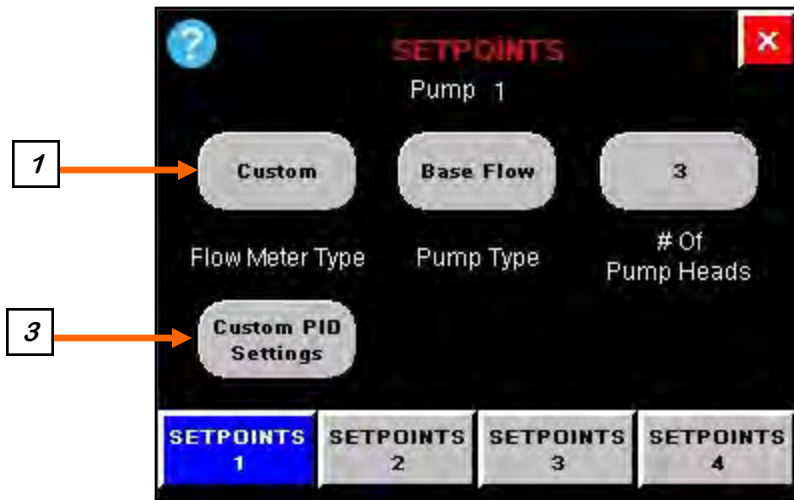

3. CUSTOM PID SETTINGS: Pressing this button advances the operator to the Custom PID Settings screen. If the flow meter type is set to Custom, the PID settings may need to be set on this screen (below).

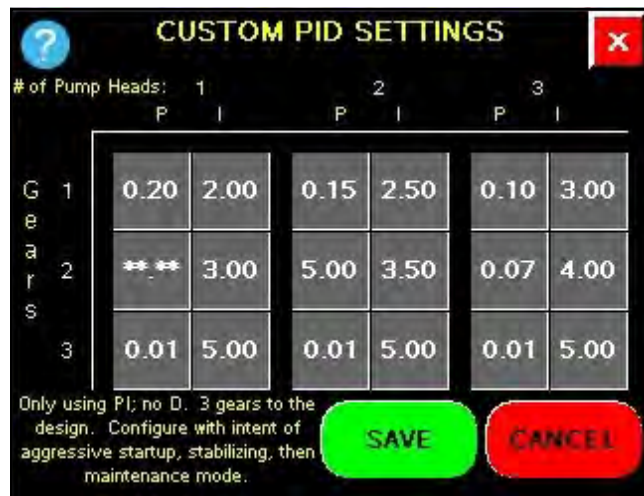

This screen allows the operator to manually enter custom PID settings for single or multiple head pumps. The system default settings are shown above. This screen is only used when non-USC pumps are being used and even then it may not be necessary to make any changes. If the operator has made changes and wants to return to the default settings, they may change the entry in the first row and the first column to zero, select the red X to exit the screen. This resets the screen to the default settings.

U-BATCH™ TREATER
SETPOINTS 2 SCREENS

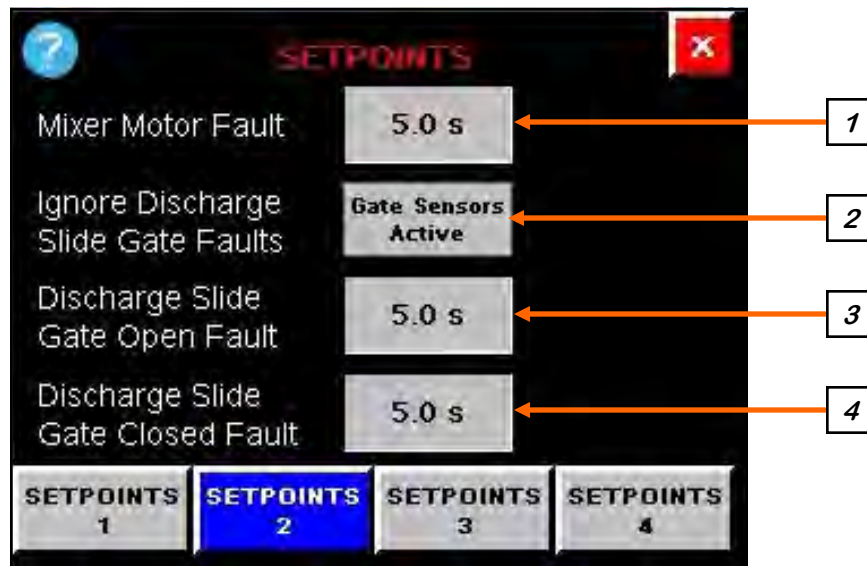

1. MIX MOTOR FAULT: Pressing this button pops up a numeric keypad allowing the operator to enter the number of seconds from the time the mix motor start button is pressed to the alarm activating if the motor does not start.

2. IGNORE DISCHARGE SLIDE GATE FAULTS: When this button is grey, the gate sensors are active and will alarm after a pre-defined number of seconds has passed, and the gate has not moved after the OPEN or CLOSE button is pushed on the Gates HOA screen. Pressing the button will turn the button red and make the gate sensors inactive. With the sensors inactive, there will be no alarm if the gate fails to open or close completely.

3. DISCHARGE SLIDE GATE OPEN FAULT: Pressing this button pops up a numeric keypad allowing the operator to enter the number of seconds from the time the Discharge Gate OPEN button is pressed to alarm if the gate does not fully open.

4. DISCHARGE SLIDE GATE CLOSED FAULT: Pressing this button pops up a numeric keypad allowing the operator to enter the number of seconds from the time the Discharge Gate CLOSED button is pressed to alarm if the gate does not fully close.

U-BATCH™ TREATER
SETPOINTS 3 SCREENS



1. VFD ERROR FAULT: Pressing this button pops up a numeric keypad allowing the operator to enter the number of seconds from the time a VFD fault is detected until the system alarm activates.

2. DISCHARGE OPEN /W INGREDIENTS: Pressing this button pops up a numeric keypad allowing the operator to enter the number of seconds until an alarm sounds from the time either of the pump stand motors start or the air begins to feed powder from the applicator when the discharge gate is in the open position.

3. AIR SEAL WARNING: Pressing this button pops up a numeric keypad allowing the operator to enter the number of seconds from the time the Air Seal should begin before issuing a warning. It is unlikely this will activate because the Mixer and Air Seal buttons are interlocked

4. OVER MIX WARNING: Pressing this button pops up a numeric keypad allowing the operator to enter the maximum number of seconds that a batch may run before a popup warning informs the operator that it has been running longer than the amount of time designated here.

U-BATCH™ TREATER
SETPOINTS 4 SCREENS

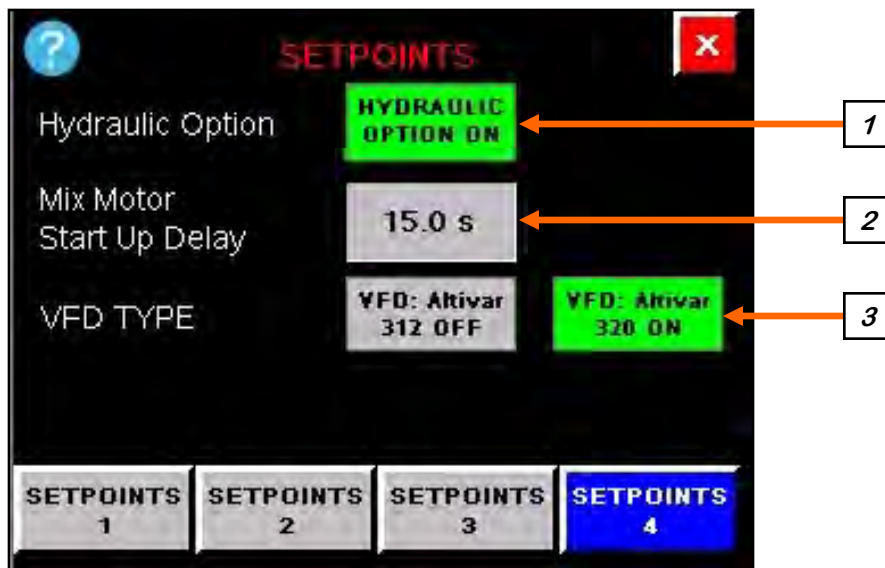

1. HYDRAULIC OPTION: Pressing this button toggles the hydraulic lift option on and off. When it is active, it will be green.

2. MIX MOTOR START UP DELAY: Pressing this button pops up a numeric keypad allowing the operator to enter the number of seconds from the time the mix motor start button is pressed until the motor has reached the pre-defined speed. This must be operating at that speed before the next step in the blending process can begin. 15 seconds is the default setting, this should work for most installations.

3. VFD TYPE: Select the VFD type used in your control panel.

ALARMS SCREEN

When a fault or warning condition is detected by the system, an Alarm popup screen will appear describing the cause of the alarm or fault. If running, the system will then progress to the pause state. When the fault condition is resolved, press the Reset & Close button, the alarm will be cleared and removed from the screen. This may also be done on the Alarms screen.

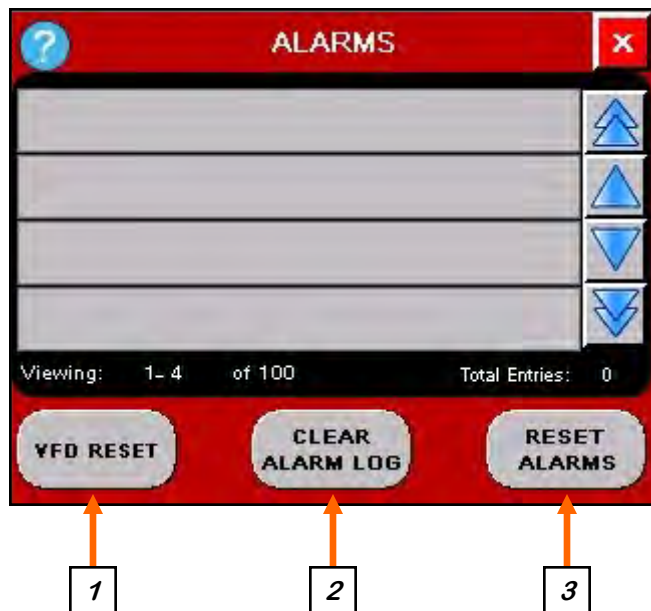

1. VFD RESET BUTTON: Pressing this button advances the operator to the VFD Fault Message screen (page 51, top). The text in the white box will describe the last VFD fault. Press the red Reset the VFD Fault button below the message window. After the VFD has reset, the button will return to grey and indicate No VFD Fault.

ALARMS SCREEN

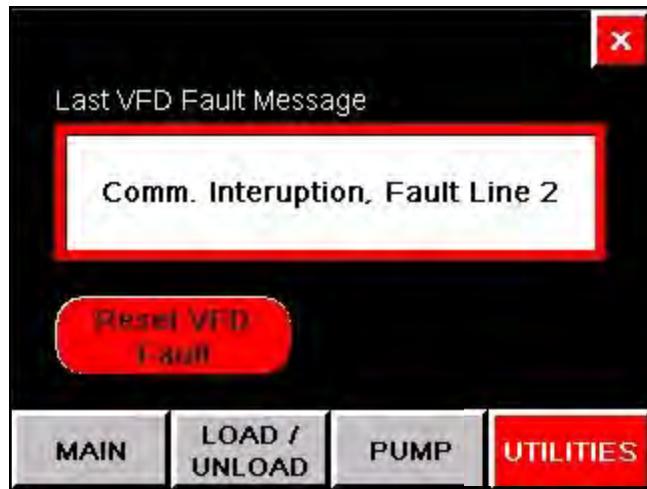

2. CLEAR ALARM LOG: All active alarms are shown in red. When an alarm is cleared, it will turn green but remain in the alarm log. Pressing this button will delete all cleared alarms in the log.

2. RESET ALARMS: After an alarm issue has been resolved, pressing this button will make the alarm inactive and turn green. The operator may now resume the batch run.

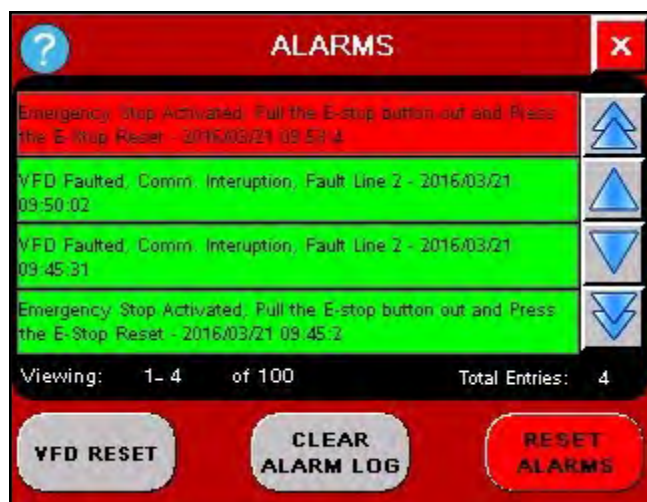

SYSTEM SETTINGS

If this is the first time using the equipment, check the Tools & Options and Setpoints screens to see if you need to change any of your basic parameters.

1. From the tools and options screen, set the date and time as well as unit of measure. If you intend to manually use the pause button at any time during the treating process, it is recommended that you enable the air seal for the pause state to avoid leakage at the base of the hopper.
2. Return to the Utilities screen and press the Setpoints button. If the button is not present, go to security screen and login as USC. Review the four setpoints screens to verify the settings are correct for your installation. The default time settings are factory set are good numbers to start with. After your fist couple of treating runs you may wish to adjust some of the times.

TREATING PROCESS FOR RIGID LEG INSTALLATION

1. Place a box of seed on the dump hopper frame and open the gate.
2. From the Load / Unload screen, press and hold the Load Treater button for two seconds.
3. After the mix motor reaches speed, start the inlet conveyor. Once all of the seed is in the treater, press the load treater Stop button.
4. Move the empty pro box under the treater discharge chute.
5. From the Pump screen, press the Liquid Selection button and follow the popup screens to select the chemical you wish treat the seed with.
6. From the Main screen, press the Start Setup button. Review the settings from the Blend Setup screen. If any parameters need to be changed, press the Adjust Settings button and make the changes. If you are not using any auxiliary pump stands, set the time for Auxiliary 1 Run Time: and Auxiliary 2 Run Time: to zero. Return to the previous screen, press and hold the Start Blend button for two seconds.
7. After the batch run is complete, return to the Load / Unload screen. Press and hold the Unload Treater button for two seconds and let the system run until all of the seed is discharged to the empty pro box. Then press the Stop button.
8. Place another box of seed on the dump hopper and repeat the process.

TREATING PROCESS FOR HYDRAULIC LIFT INSTALLATION

1. If the treater is not in the bottom position, go to the Load / Unload screen and press the Lower Treater button and hold it for two seconds.
2. Lift a box of seed and position the gate over the center of the inlet hopper.
DO NOT open the gate.
3. From the Load / Unload screen, press and hold the Load Treater button for two seconds.
4. After the mix motor reaches speed, open the gate on the pro box. Once all of the seed is in the treater, press the load treater Stop button.
5. Lower the empty pro box to the ground and position it in front of the discharge chute.
6. From the Load / Unload screen and press the Raise Treater button and hold it for two seconds.
7. After the treater is in the top position, move the empty pro box under the discharge chute.
8. From the Pump screen, press the Liquid Selection button and follow the popup screens to select the chemical you wish treat the seed with.
9. From the Main screen, press the Start Setup button. Review the settings from the Blend Setup screen. If any parameters need to be changed, press the Adjust Settings button and make the changes. If you are not using any auxiliary pump stands, set the time for Auxiliary 1 Run Time: and Auxiliary 2 Run Time: to zero. Return to the previous screen, press and hold the Start Blend button for two seconds.
10. After the batch run is complete, return to the Load / Unload screen. Press and hold the Unload Treater button for two seconds and let the system run until all of the seed is discharged to the empty pro box. Then press the unload treater Stop button.
11. Remove the full pro box from under the treater and press the Lower Treater button, hold it for two seconds. When it is in the bottom position you are ready to repeat the process.

TROUBLESHOOTING

Below is a table describing the most frequent problems and solutions with the U-Batch™ Treater . For further assistance, contact the USC Service department at (785) 431-7900.

Problem	Possible Cause	Solution
System has power but will not start .	<ol style="list-style-type: none"> 1. E-Stop switch engaged. 2. Motor VFD fault. 	<ol style="list-style-type: none"> 1. Pull out E-Stop switch and press E-Stop reset button. 2. Reset VFD and clear alarm.
Discharge gate will not completely close.	<ol style="list-style-type: none"> 1. Tubing to cylinder not connected. 2. Lack of air pressure. 3. Debris not allowing gate to close. 	<ol style="list-style-type: none"> 1. Check pneumatic connection to air cylinder. 2. Check pneumatic connections and pressure regulation. 3. Power unit down and clear debris from discharge gate. Power up unit and press the discharge gate CLOSE button.
Pump is fluctuating.	<ol style="list-style-type: none"> 1. Restriction in tubing 2. Filter is plugged or missing gasket. 3. Hoses are worn out. 	<ol style="list-style-type: none"> 1. Flush tubing and check filter for any restrictions. 2. Clean filter and check for gasket. 3. Replace hoses.
Pump Stand mix motor will not start	<ol style="list-style-type: none"> 1. Power cord not plugged in. 	<ol style="list-style-type: none"> 1. Plug in power cord.
Powder not being delivered to top of coater	<ol style="list-style-type: none"> 1. Powder hopper is empty. 2. Lack of air pressure. 	<ol style="list-style-type: none"> 1. Check powder hopper, fill as needed. 2. Check pneumatic connections and pressure regulation.

MAINTENANCE**SECTION
G**

Proper maintenance of the U-Batch™ Treater is critical for peak performance, reliability and accuracy of this system. The following is a guideline for the type of maintenance and servicing that should be performed on this unit. Your environment and uses may require additional maintenance and service beyond this list to assure a reliable and safe unit. The operator of this unit has ultimate responsibility to identify areas of concern and rectify them before they become a hazard or safety issue. There is no substitute for a trained, alert operator.



Do not put this unit into operation with any questionably maintained parts. Poor performance or a hazard may occur.

FLUIDS AND LUBRICANTS**Grease**

Use an SAE multipurpose high temperature grease with extreme pressure (EP) performance. Also acceptable is an SAE multipurpose lithium-based grease.

Hydraulic Oil

Use DTE 25 hydraulic oil for Electric Powered Hydraulic Pump.

Lubrication Oil

The lubricant is a factory filled high performance, H1 grade synthetic. The standard ambient temperature range is –10 degrees to +130 degrees Fahrenheit. Other lubricants, including Mobile SHC series must not be mixed with the factory supplied lubricant.

Storing Lubricants

Your machine can operate at top efficiency only if clean lubricants are used. Use clean containers to handle all lubricants. Store them in an area protected from dust, moisture and other contaminants.

GREASING

Use a Maintenance Checklist to keep record of all scheduled maintenance.

1. Use a hand-held grease gun for all greasing.
2. Wipe grease fitting with a clean cloth before greasing to avoid injecting dirt and grit.
3. Replace and repair broken fittings immediately.

NOTICE

If fittings will not take grease, remove and clean thoroughly. Also clean lubricant passageway. Replace fitting if necessary.

DRIVE ASSEMBLY

- Remove drive belt guards and check for any play in the drive motor or reducer shafts.
 - Check the drive belt tension. Adjust if necessary (see page 58).
 - Grease the upper and lower auger shaft bearings every 40 hours of operation.
 - The reducer is filled with synthetic lubricant and requires no periodic maintenance. However, an occasional visual inspection to check for hardware tightness, leakage and the general overall condition of the reducer is good practice.
-

COATING HOPPER

- Run clean water through the static mixer assembly and purge with compressed air regularly to avoid chemical build-up.
 - Clean the entire hopper, including the slide gate assembly with clean water regularly to avoid chemical build-up.
 - Grease the upper and lower auger shaft bearings every 40 hours of operation.
-

ELECTRICAL PANEL

- Check and tighten wire connections.
- Check quick connects on bottom of control panel.
- Check to see if starters and/or overloads are tripped.
- Check to see if relays, timers and/or breakers are tripped.
- Check quick connects on end of Auxiliary cord.
- Check and tighten wire connections.
- Check relay and fuse holder.
- Check power cords for cuts or frays and ensure ground is present.

U-BATCH™ TREATER
HYDRAULIC SYSTEM

1. Check gauge on hydraulic fluid filter. If operational pressure in the filter is registering in the red zone on the gauge, replace filter (right).



2. Check fluid level window on the front of the fluid reservoir (left). It should show fluid half way in the window cold. If it does not, add fluid.

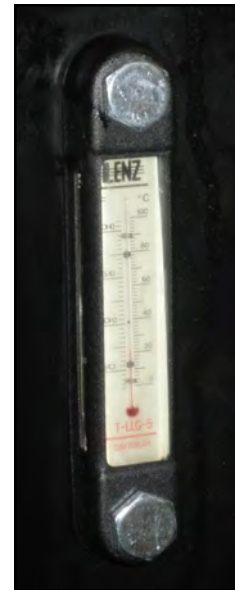

**SECTION
H**

BELT TENSIONING SPECIFICATION

Synchronous Belts

High torque, Standard and Metric synchronous belts should be installed to fit pulleys snugly, neither too tight nor too loose. The belts positive grip eliminates the need for high initial tension. When a belt is installed with a snug but not overly tight fit, longer belt life, less bearing wear and more quiet operation will result. Over tight belts may cause early failure and should be avoided. With high torque a loose belt may “jump teeth” upon startup. If this occurs, the tension should be increased gradually until satisfactory operation is achieved.

To properly tension a synchronous belt, place belt on pulleys and adjust take up until the belt teeth mesh securely with the pulley grooves. Measure belt span “T”. Then tighten belt so it deflects 1/64-inch for every inch of belt span when a force as specified in the table below is applied to the top of the belt. For belts wider than two inches, a metal or wooden strip 3/4 to 1 inch wide should be placed across the belt between it and the tester to prevent distortion.

The following range of deflection forces are normally adequate for a used drive belt.

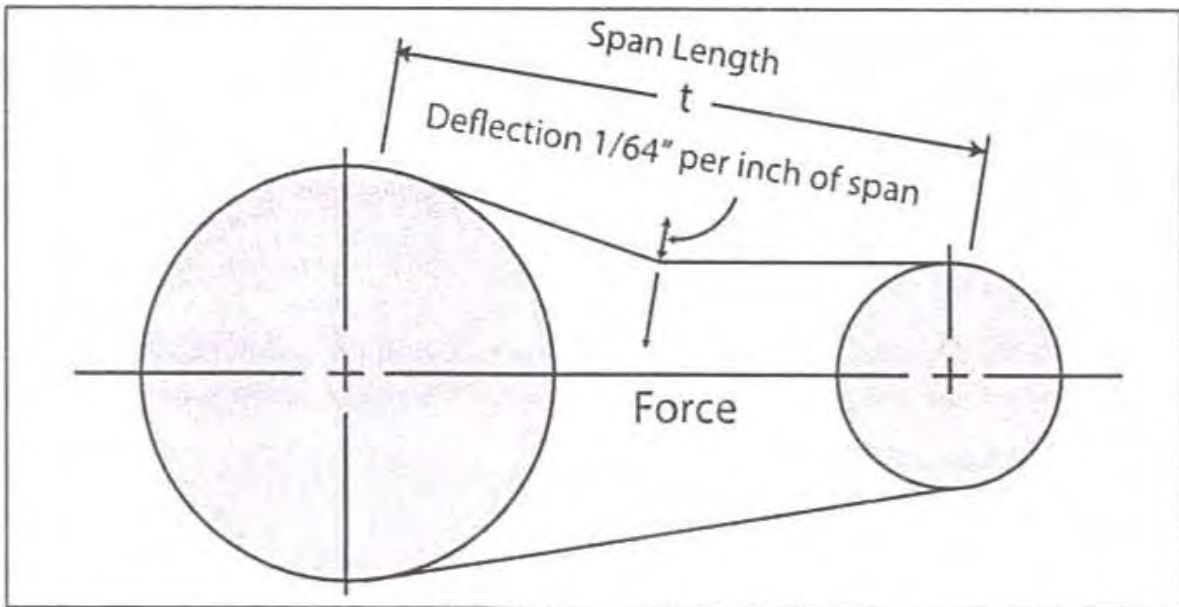

BELT PITCH	BELT WIDTH	DEFLECTION FORCE
POLY CHAIN SYNCHRONOUS	8MM	8.0 to 8.8 lbs
POLY CHAIN SYNCHRONOUS	14MM	25 to 27 lbs

When storing the U-Batch™ Treater for long periods of time, the following procedure must be followed to reduce the chance of rust, corrosion and fatigue of the conveyor. You can also use these steps when storing the machine for the winter.



A dust mask and protective rubber gloves shall be used when cleaning the machine.

1. Clear the area of bystanders, especially small children.
2. Thoroughly wash the entire machine to remove all dirt, mud, debris or residue.
3. Inspect all moving or rotating parts to see if anything has become entangled in them. Remove the entangled material.
4. Lubricate all grease fittings. Make sure that all grease cavities have been filled with grease to remove any water residue from the washing. This also protects the bearing seals.
5. Remove drive assembly covers. Clean entire area and ensure drive belts are clean and free of debris.
6. Touch up all paint nicks and scratches to prevent rusting.
7. Store the machine inside a protective building to keep it from being exposed to the weather. Select an area that is dry, level and free of debris. If storing outside, cover with a waterproof tarpaulin.
8. Store machine in an area away from human activity.
9. Do not allow children to play on or around the stored machine.

U-BATCH™ TREATER

NOTES:

MECHANICAL DRAWINGS

SECTION J

AUGER DRIVE MOTOR (03-20-0172)

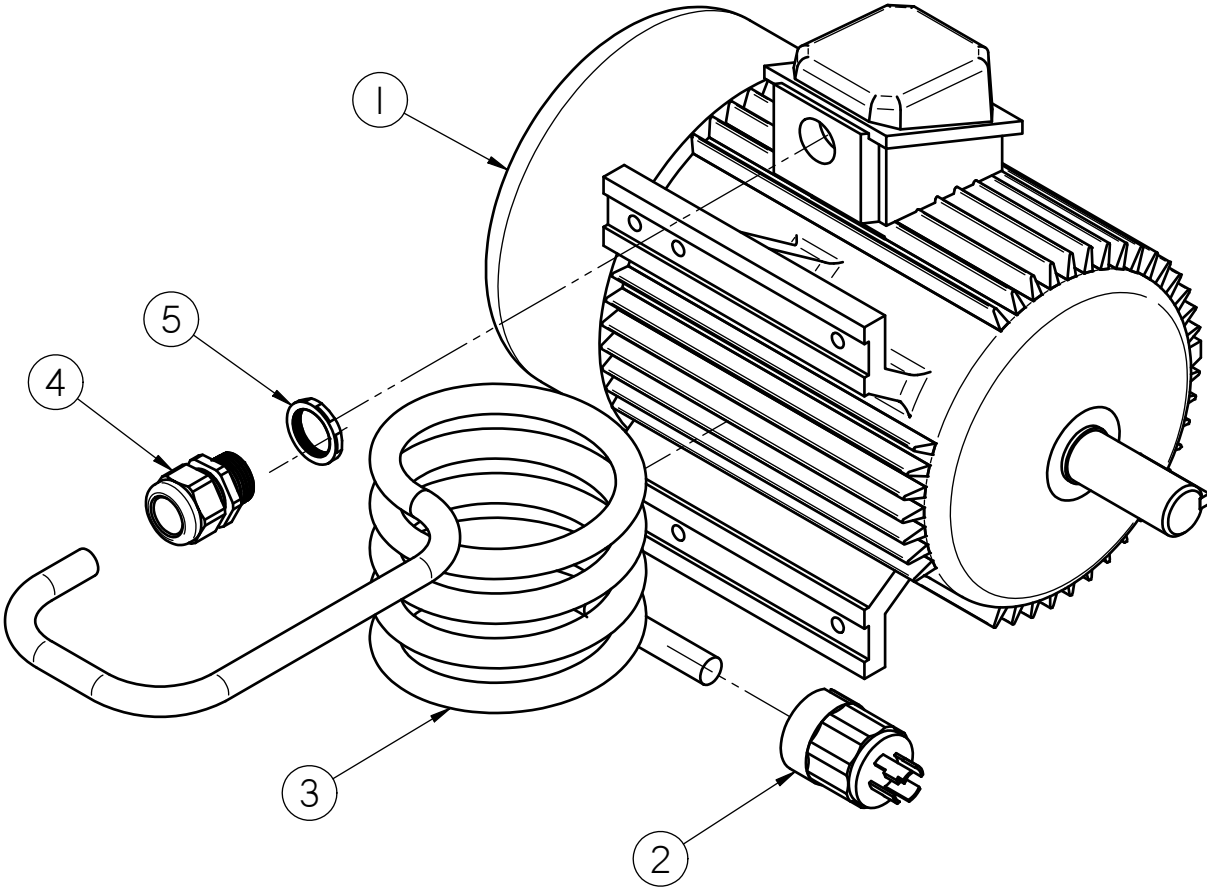

Item #	Part #	Description	Qty
1	01-01-0152	MTR EE 10HP 1760RPM 215T TEFC 3PH	1
2	03-06-0112	PLUG 3PL 4WIRE TWLK 250V 30A IP66	1
3	03-07-0011	WIRE 10/4 SEOWW CORD	300 in
4	03-08-0301	CONN CG 1.0NPT .590-1.00 8438 LTF	1
5	03-08-0310	NUT NYLOC 1.00 NPT 8468	1

U-BATCH™ TREATER

HYDRAULIC POWER PACKAGE ASSEMBLY (13-08-0681)

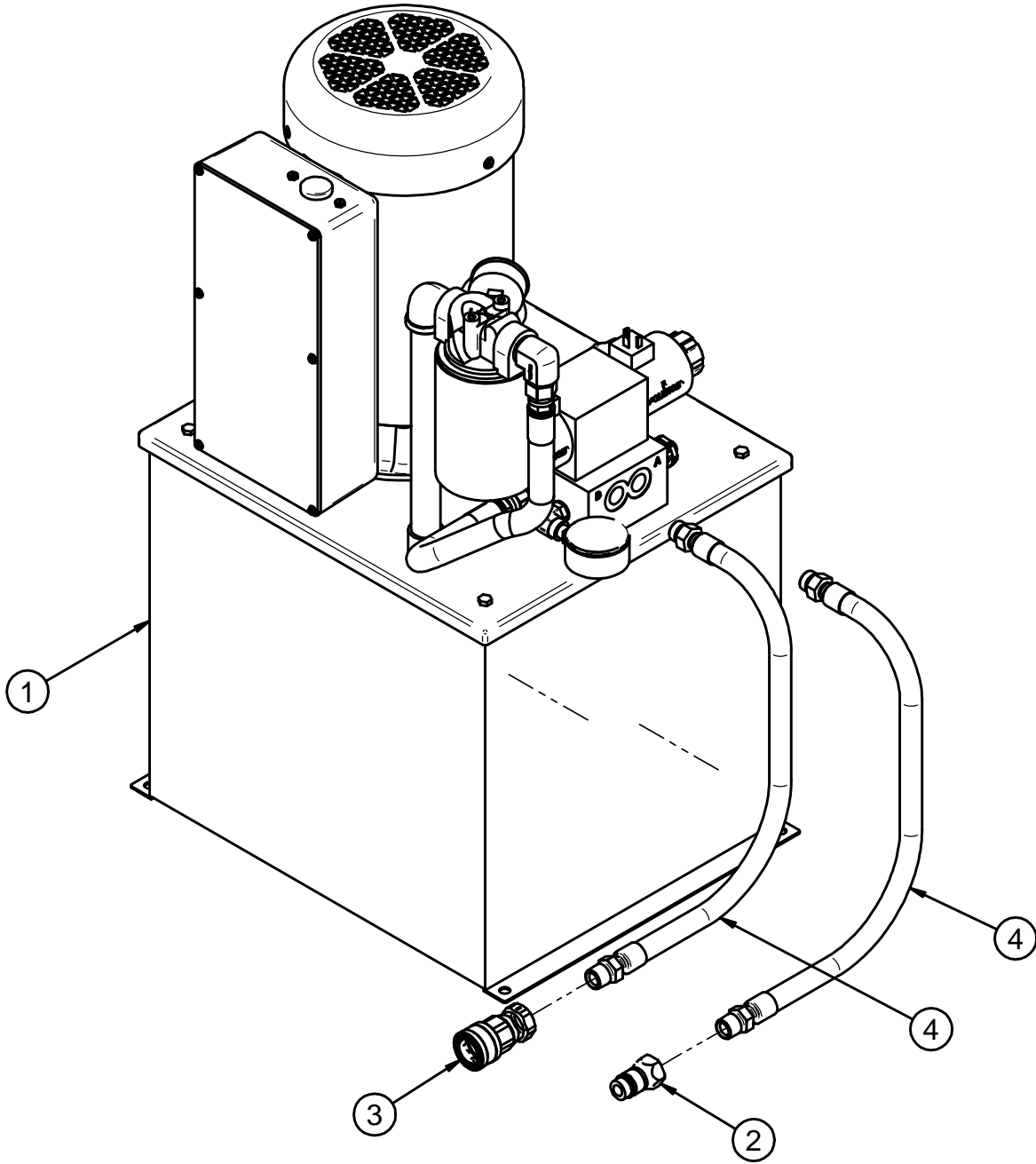

Item #	Part #	Description	Qty
1	01-01-0237	HYD PWR PKG 5HP 230V 1PH 6.7 GPM*	1
2	02-05-0067	FTTG HYD QCK .500 NPT ISO 5675	1
3	02-05-0133	FTTG HYD QCK .5 FM BODY X .500 FNPT	1
4	13-05-0550	HHA .375ID 024.0IN -08MOR -08MP	2

POWDER AGITATION SHAFT ASSEMBLY (05-08-0474)

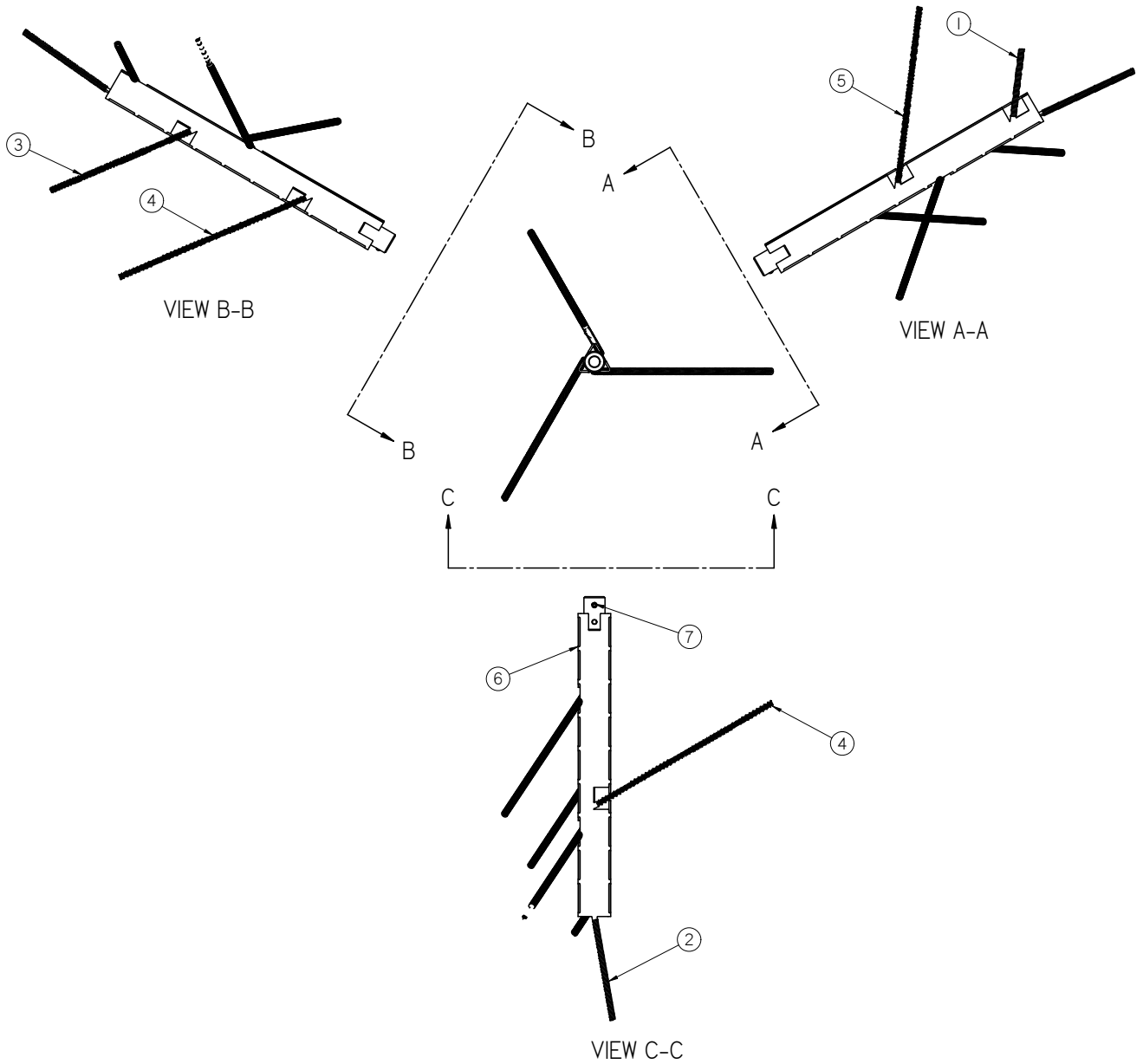

Item #	Part #	Description	Qty
1	01-04-0079	SPG EXT .375OD .063 WIRE 4IN LG	1
2	01-04-0080	SPG EXT .375OD .063 WIRE 6IN LG	1
3	01-04-0081	SPG EXT .375OD .063 WIRE 9IN LG	1
4	01-04-0082	SPG EXT .375OD .063 WIRE 12IN LG	2
5	01-04-0083	SPG EXT .375OD .063 WIRE 10.5IN LG	1
6	05-08-0473	WDMT SHAFT AGITATION POWDER SS	1
7	06-06-0085	SETSCREW .312-18 X .375 SS CUP PNT	1

U-BATCH™ TREATER
CONVEYOR AIR INLET ASSEMBLY (05-07-0811)

GLUE THESE COMPONENTS TOGETHER

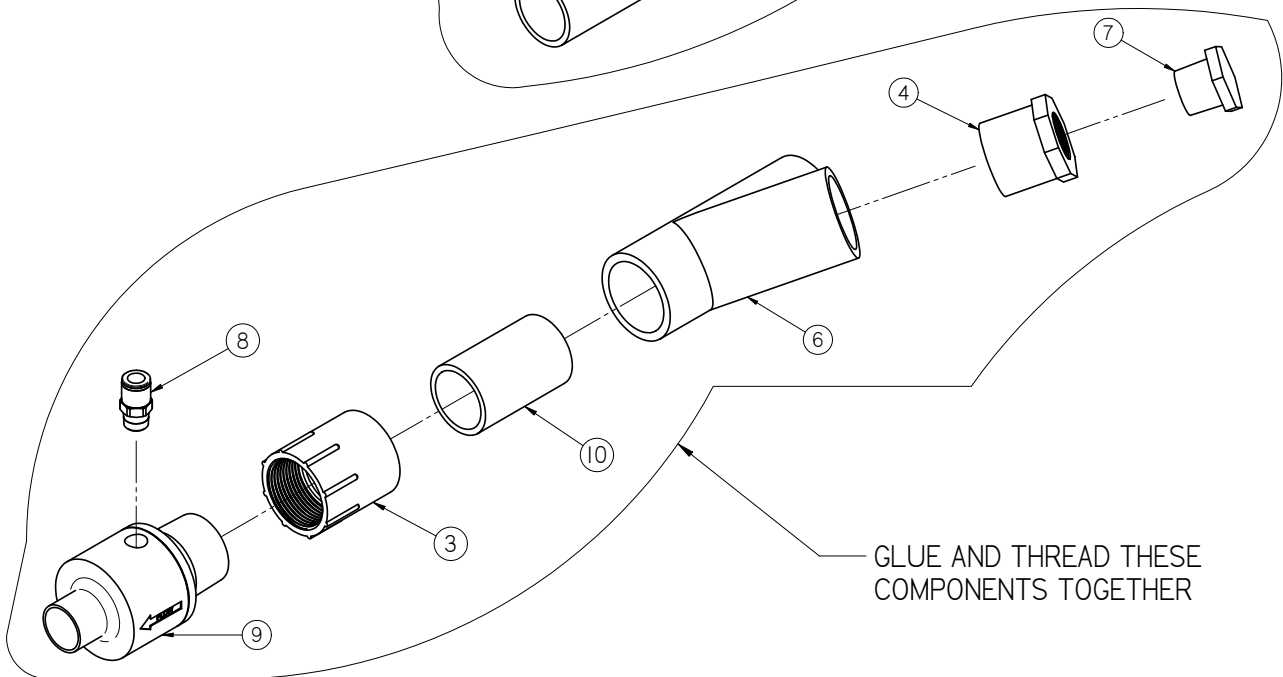
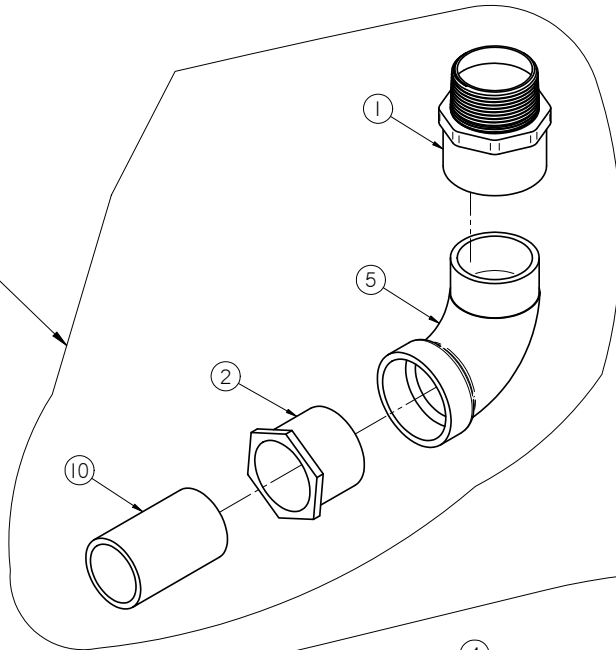

GLUE AND THREAD THESE COMPONENTS TOGETHER

U-BATCH™ TREATER
CONVEYOR AIR INLET ASSEMBLY (05-07-0811)

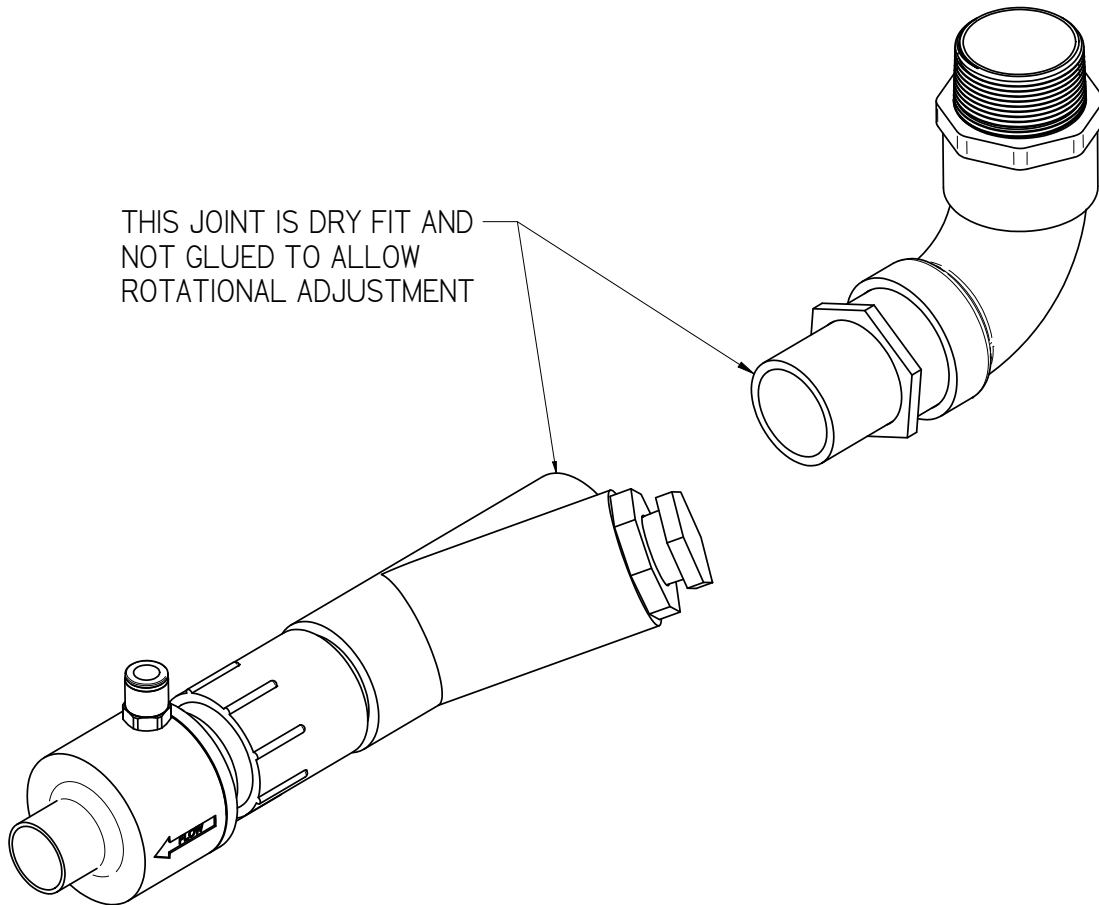

Item #	Part #	Description	Qty
1	02-04-0040	FTTG ADPT 1.50 SCKT X 1.50 MNPT PVC	1
2	02-04-0041	FTTG BUSH 1.50 SCKT X 1.25 SCKT PVC	1
3	02-04-0042	FTTG ADPT 1.25 SCKT X 1.25 FNPT PVC	1
4	02-04-0043	FTTG ADPT 1.25 SCKT X 0.75 FNPT PVC	1
5	02-06-0085	FTTG 90 DEG STRT 1.50 SCKT WELD PVC	1
6	02-10-0005	FTTG WYE 1.25 SCKT PVC	1
7	02-14-0014	FTTG PLUG .750-14 NPT PLUG BP	1
8	02-16-0015	FTTG PUSH .375OD X .250 NPT ML	1
9	04-04-0015	LINE VAC 1.25NPT IN 1.25OD OUT	1
10	103F2D	NIPPLE 1.25 OD PVC	2

POWDER AGITATION HOPPER ASSEMBLY (13-05-0500)

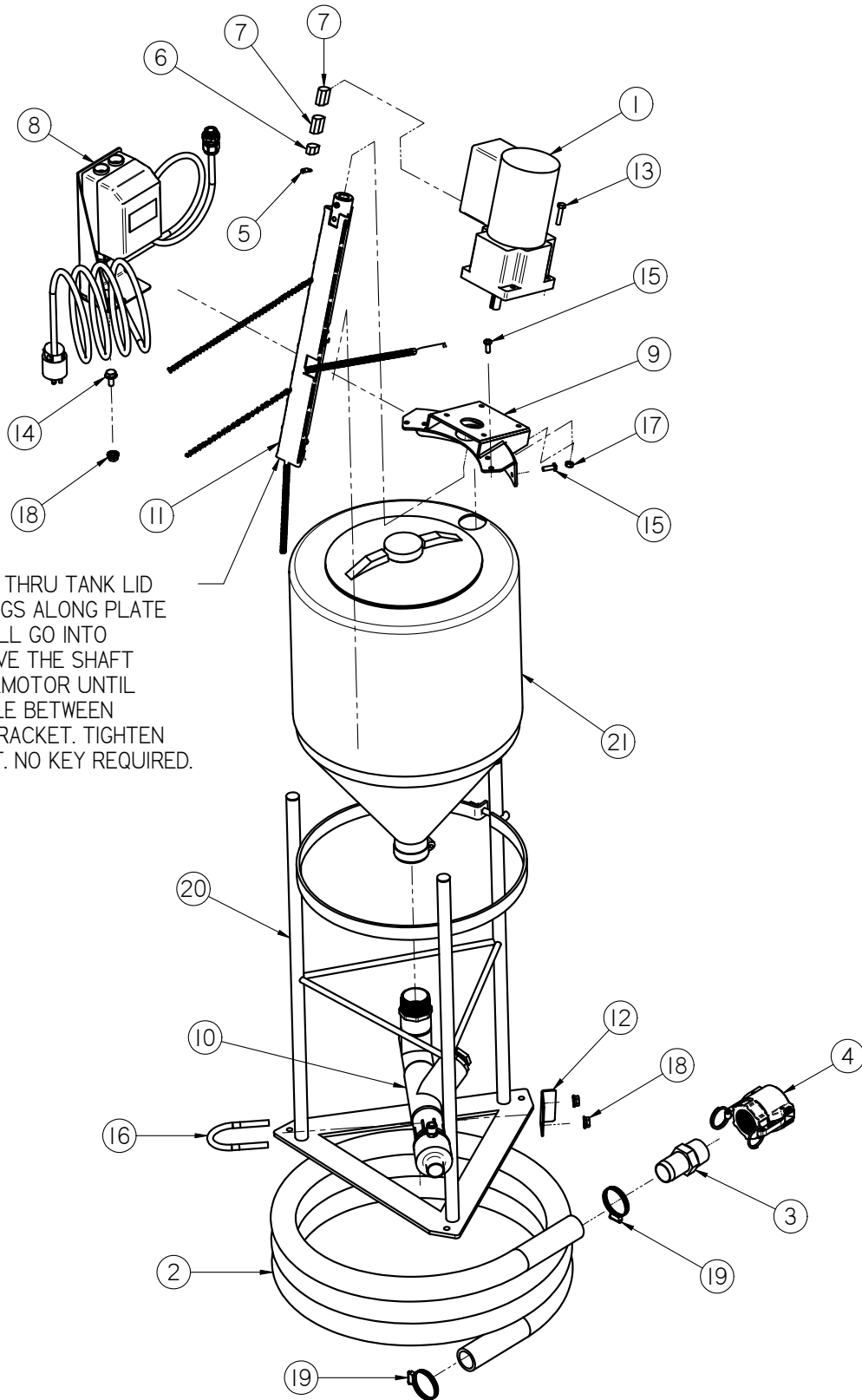

INSTALL AGITATOR IN THRU TANK LID WHILE HOLDING SPRINGS ALONG PLATE SIDES. END SPRING WILL GO INTO DISCHARGE HOLE. MOVE THE SHAFT COUPLER ONTO GEARMOTOR UNTIL SET SCREW IS VISIBILE BETWEEN PLATES ON MOUNT BRACKET. TIGHTEN SET SCREW TO SHAFT. NO KEY REQUIRED.

POWDER AGITATION HOPPER ASSEMBLY (13-05-0500)

Item #	Part #	Description	Qty
1	01-01-0182	MOTOR .16HP 9075 RPM 1PH	1
2	02-03-0027	HOSE PVC 1.250 ID CLEAR LINE VAC - FEET	15
3	02-08-0036	FTTG STGHT 1.25HB X 1.25NPT PP	1
4	02-15-0050	FTTG CPLG CAM LVR 1.5FM X 1.25 FNPT	1
5	03-08-0201	CONN RING TMNL 14-16AWG #6-10 STUD	1
6	03-08-0268	CONN COMPACT TNML BLK 2-CON 222-412	1
7	03-08-0270	CONN COMPACT TNML BLK 5-CON 222-415	2
8	03-13-0030	KIT SW MNL MP .07 HP MIX MTR 1-1.6A	1
9	05-03-1578	WDMT FR GMTR MNT	1
10	05-07-0811	CNVR AIR 1.25OD OUT 1.50 FNPT INLET	1
11	05-08-0474	ASSY SHAFT AGITATION POWDER SS	1
12	05-10-4358	PLT BRKT CLMP U-BOLT	1
13	06-01-0008	BOLT, .250-20 X 1 1/4" UNC ZP GRADE 5	4
14	06-01-0124	BOLT FLG .375-16 X .750 ZP GR5	1
15	06-01-0215	SCRW MACH #14 X .750 SS PLASTITE	6
16	06-01-0294	BOLT U .375-16 X 2.50 X 3.625 ZP	1
17	06-02-0001	NUT FULL .250-20 ZP GR5	4
18	06-03-0014	NUT LOCK FLG .375-16 ZP GR5	3
19	06-07-0019	HOSE CLAMP, 1.00" to 2.00"	2
20	07-02-0034	WDMT FR 7-10GAL CONE BTM TNK	1
21	07-02-0035	TNK 10GAL 55 DEG 1.50 FNPT FD	1

U-BATCH™ TREATER
STATIC MIXER ASSEMBLY (04-03-0289)

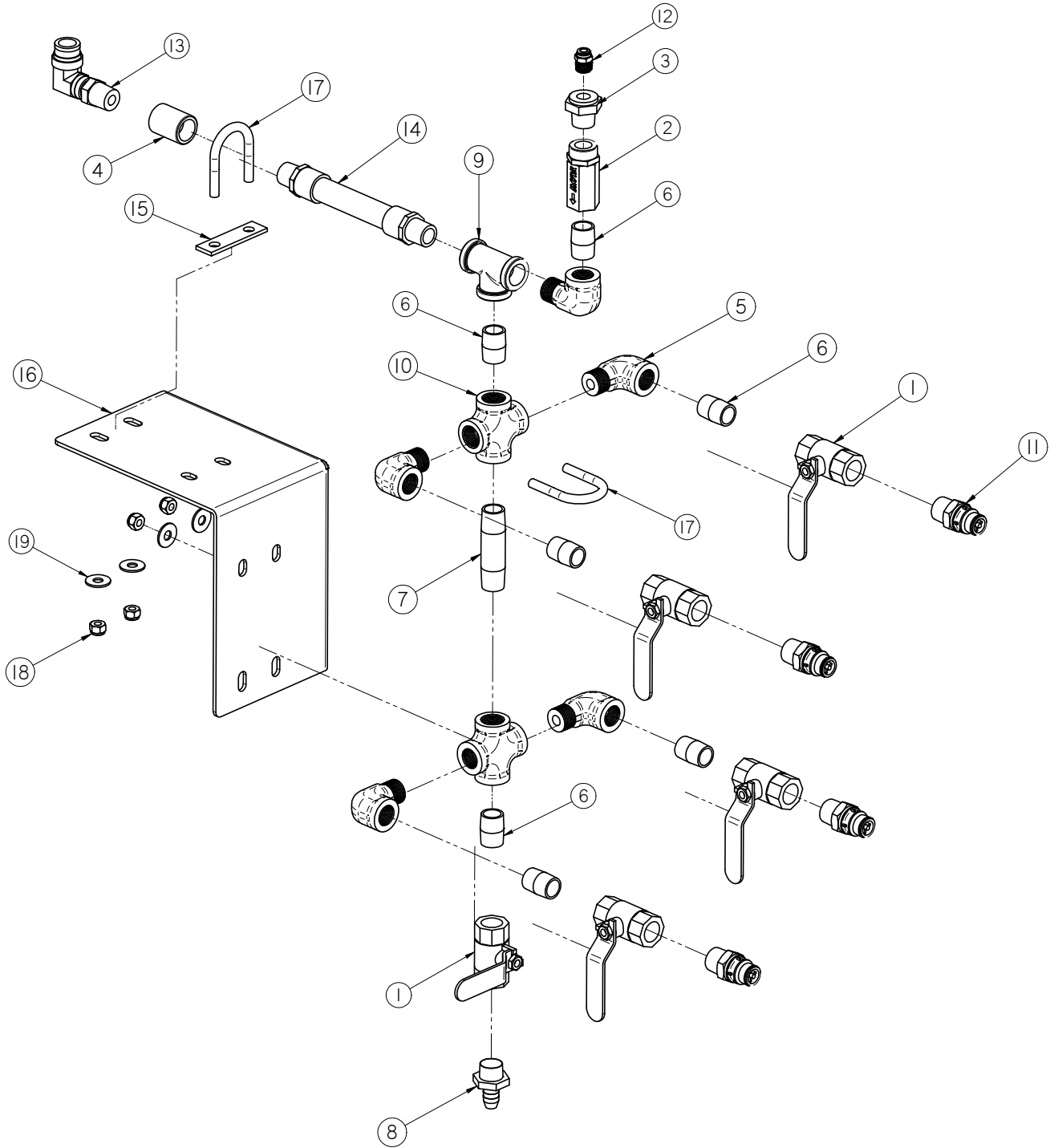

U-BATCH™ TREATER

STATIC MIXER ASSEMBLY (04-03-0289)

Item #	Part #	Description	Qty
1	02-02-0006	.500-14 NPT X 2-WAY VALVE	5
2	02-02-0008	CHECK VALVE, .500 SS	1
3	02-04-0057	FTTG BUSH .500NPT X.250NPT SS	1
4	02-05-0005	FTTG CPLG .500 NPT FM SS	1
5	02-06-0020	FTTG 90 DEG STRT.500NPTX .500NPT SS	5
6	02-07-0007	FTTG NIP .500NPTX1.125 TBE SS CLOSE	7
7	02-07-0019	FTTG NIP .500 NPT X 3.00 TBE SS	1
8	02-08-0007	FTTG STGHT .500HB X .500NPT ML NYL	1
9	02-09-0003	FTTG TEE .500 NPT FM SS	1
10	02-11-0001	FTTG CROSS .500 NPT FM SS	2
11	02-15-0014	FTTG CPLG .500 NPT QCK DISC INSERT	4
12	02-16-0041	FTTG PUSH .250 OD X .250 NPT	1
13	02-16-0050	FTTG PUSH 90DEG .625ODX.500 NPT ML	1
14	04-03-0030	MXR IL PVC 6ELEMENT .500PIPE X 7.00	1
15	05-10-4277	SPCR STTC MXR MNT	1
16	05-10-4356	PLT STTC MIXER SUPP BATCH TRTR	1
17	06-01-0037	BOLT U .313-18 X 1.38 X 2.188 ZP	2
18	06-03-0002	NUT NYL LOCK .313-18 ZP GR5	4
19	06-05-0003	WSHR FLAT .313 ZP	4

U-BATCH™ TREATER
HOPPER LIFT ASSEMBLY (13-05-0463)

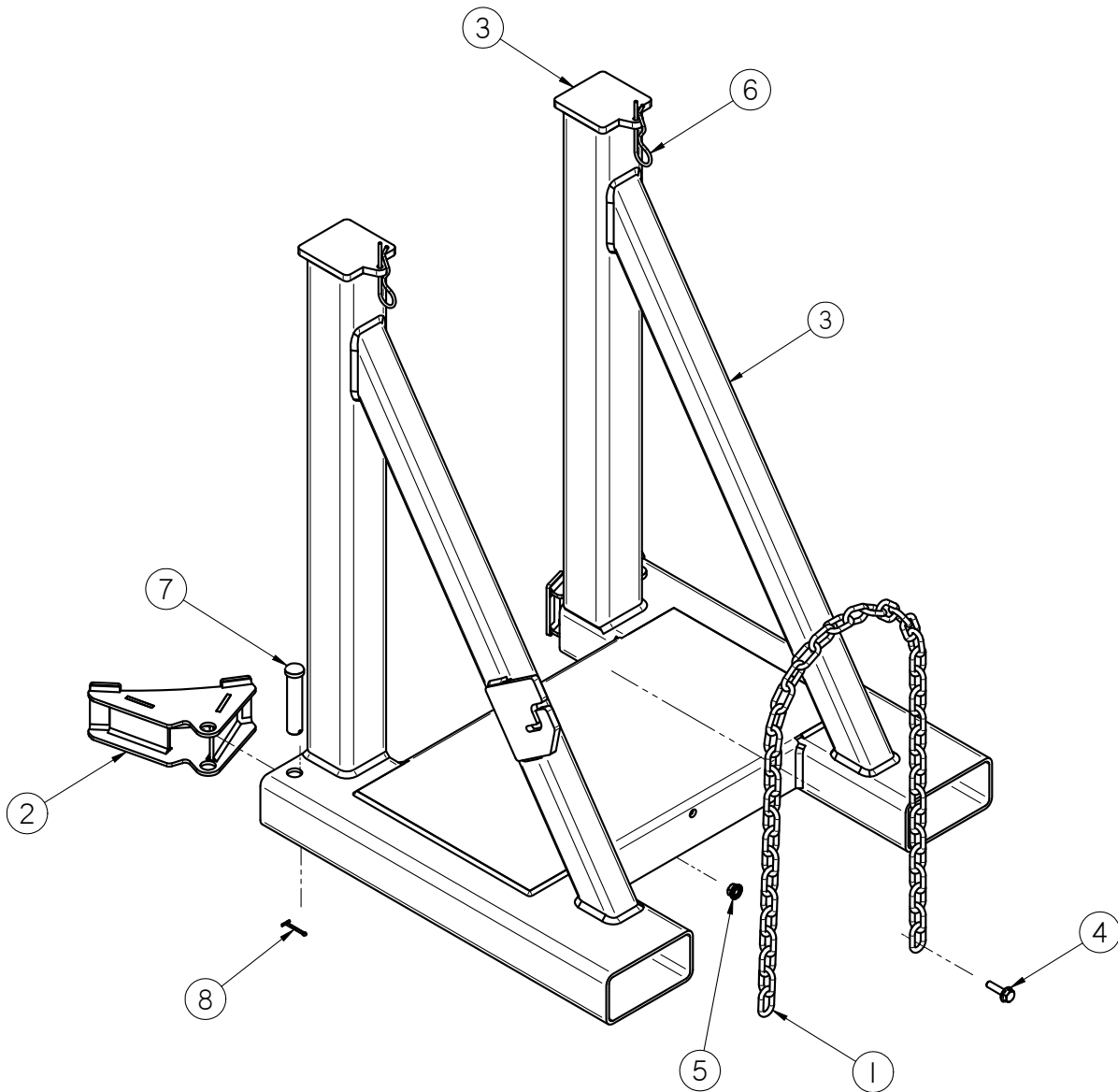

Item #	Part #	Description	Qty
1	01-04-0020	CHAIN PROOF COIL .250	48.00 in
2	05-07-0857	WDMT SWIVEL BT HOPP LIFT	2
3	05-08-0523	WDMT FR LIFTING REMV HOPP	1
4	06-01-0189	BOLT FLG .375-16 X 1.250 ZP GR5	1
5	06-03-0014	NUT LOCK FLG .375-16 ZP GR5	1
6	06-09-0002	PIN CLIP HITCH 3.063 SIZE 9 ZP	2
7	06-09-0014	PIN CLVS .750 X 3.50 ZP	2
8	06-09-0087	.125 X 1.50 ZP COTTER PIN	2

U-BATCH™ TREATER
SLIDE GATE INLET ASSEMBLY (12-04-0038)

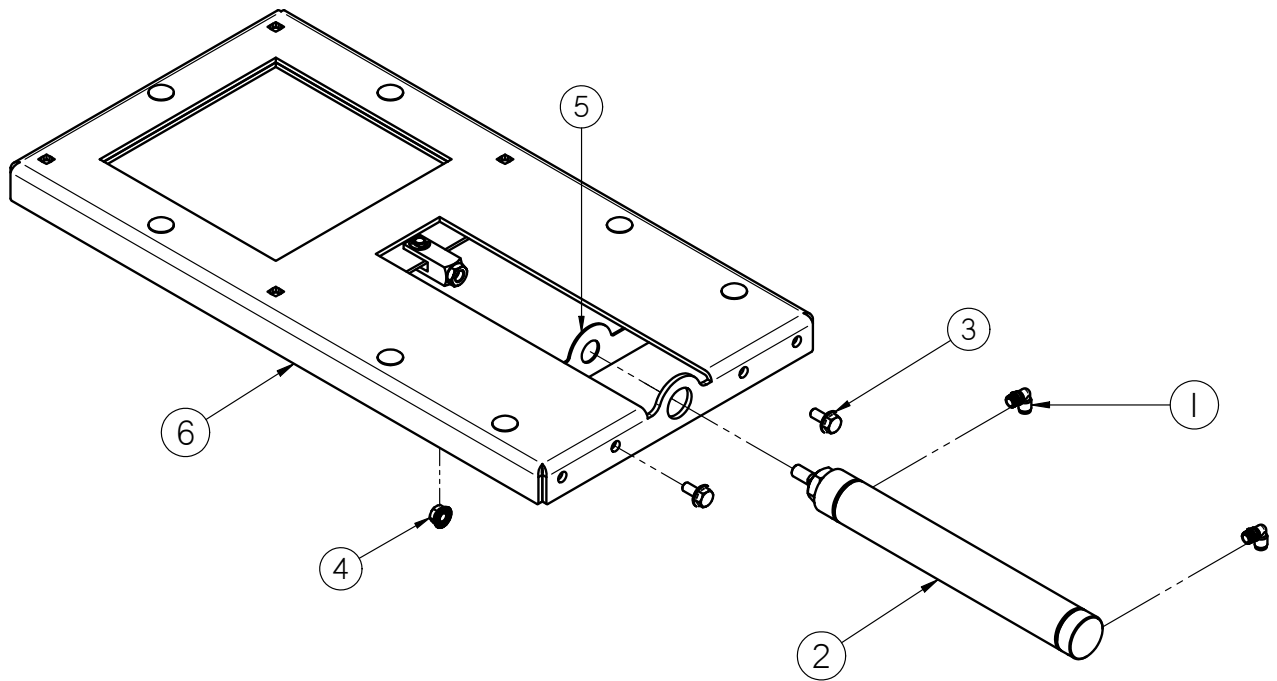

Item #	Part #	Description	Qty
1	02-16-0046	FTTG PUSH 90 DEG .250 OD X .125 NPT	2
2	03-17-0067	CYL AIR 9"STROKE 1.5 IN BORE DBL	1
3	06-01-0124	BOLT FLG .375-16 X .750 ZP GR5	2
4	06-03-0014	NUT LOCK FLG .375-16 ZP GR5	2
5	10536A	SPCR BT INLET GATE CYL	1
6	12-04-0033	SLGT 8.00 SQUARE BASE	1

HOPPER SLIDE GATE BASE ASSEMBLY (12-04-0033)

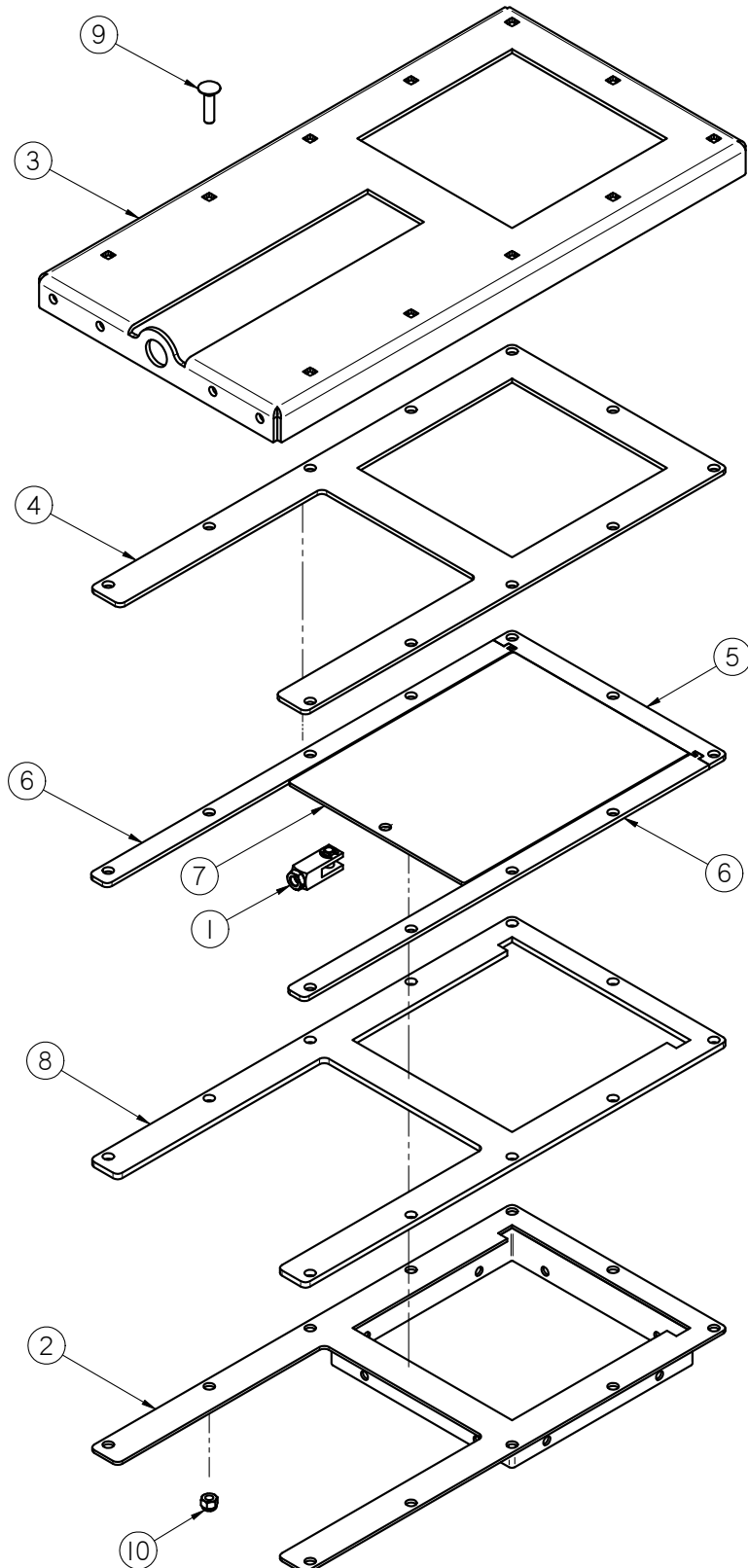

HOPPER SLIDE GATE BASE ASSEMBLY (12-04-0033)

Item #	Part #	Description	Qty
1	03-17-0046	CLEVIS ASSY BIMBA D-8311-A	1
2	05-07-0819	WDMT DSCHG 8.00IN SQ SLGT	1
3	05-10-4371	PLT SLGT BODY 8.00IN SQ	1
4	05-10-4372	PLT SLGT UHMW TOP 8.00IN SQ	1
5	05-10-4373	STOP UHMW SLGT 8.00IN SQ	1
6	05-10-4374	GUIDE UHMW SIDE SLGT 8.00IN SQ	2
7	05-10-4375	PLT SLGT 8.00IN SQ	1
8	05-10-4376	PLT UHMW LOWER SLGT 8.00IN SQ	1
9	06-01-0128	BOLT CRG .375-16 X 1.50 ZP GR5	7
10	06-03-0003	NUT NYL LOCK .375-16 ZP GR5	7

SLIDE GATE DISCHARGE ASSEMBLY (12-04-0031)

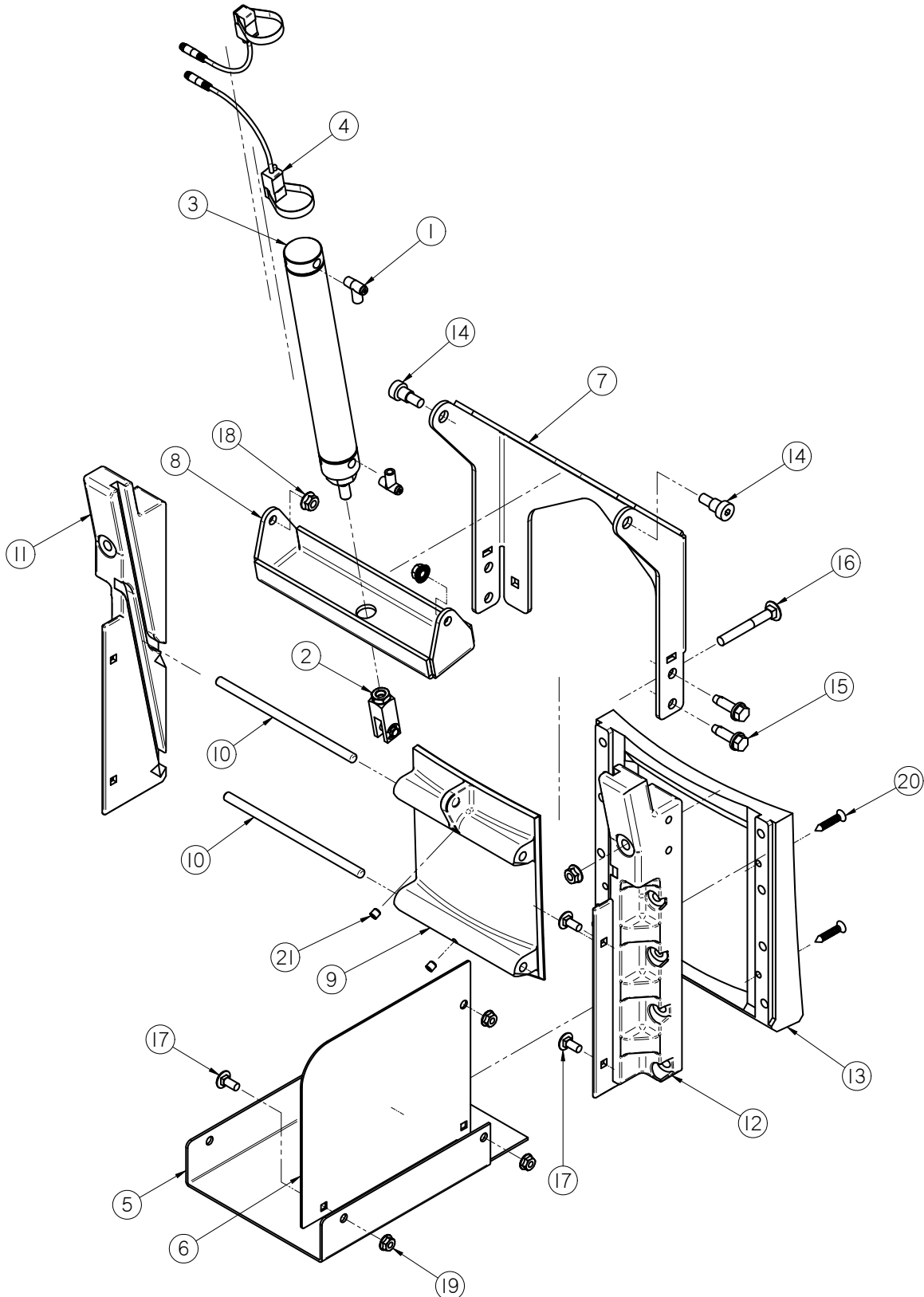

SLIDE GATE DISCHARGE ASSEMBLY (12-04-0031)

Item #	Part #	Description	Qty
1	03-17-0039	BIMBA FQPS2 FLOW CONTROL	2
2	03-17-0046	CLEVIS ASSY BIMBA D-8311-A	1
3	03-17-0067	CYL AIR 9"STROKE 1.5 IN BORE DBL	1
4	03-17-0109	SW MAG REED MRS-.087-PBLQ-17	2
5	05-10-4306	PLT CHUTE DSCHG VC	1
6	05-10-4307	PLT CHUTE DSCHG SIDE VC	2
7	05-10-4353	PLT BRKT CYL BASE	1
8	05-10-4354	PLT MNT CYL SWIVEL	1
9	05-11-0432	GATE SLIDE DSCHG BT 3DP	1
10	05-11-0437	ROD GUIDE 7IN SLGT VC	2
11	05-11-0471	GUIDE GATE SLIDE LT 3DP	1
12	05-11-0472	GUIDE GATE SLIDE RT 3DP	1
13	05-11-0473	FLG TO CONE MNT SLGT BT 3DP	1
14	06-01-0056	BOLT SHLD .500SHX.375-16X.500 GR5	2
15	06-01-0118	BOLT STHRD .375-16 X 1.250 HH ZP	4
16	06-01-0146	BOLT CRG .375-16 X 3.00 SS	2
17	06-01-0171	BOLT CRG .3125-18X.750 ZP SHORT NECK	6
18	06-03-0014	NUT LOCK FLG .375-16 ZP GR5	4
19	06-03-0019	NUT LOCK FLG .3125-18 ZP GR5	6
20	06-06-0028	SCREW #14x1.5 ZP FLAT HD SPAX	4
21	06-06-0090	SCRW SCKT .312-18 X .312 CUP PNT	2

U-BATCH™ TREATER
TOP CAP ASSEMBLY (13-05-0546)

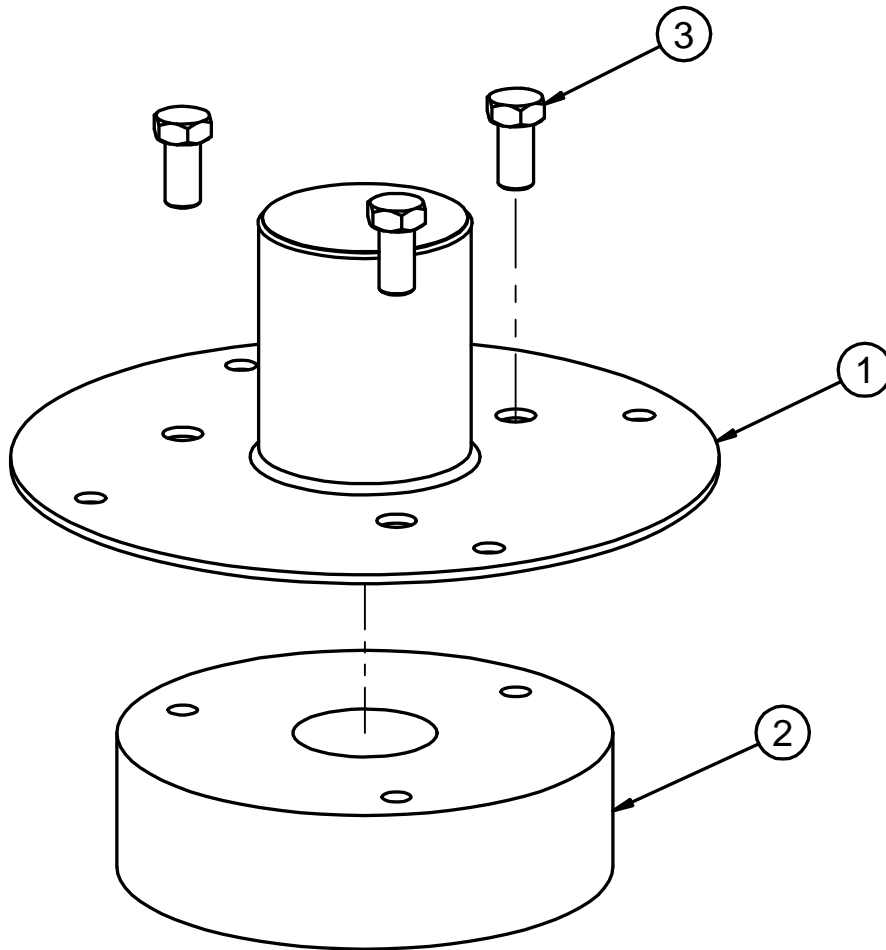

Item #	Part #	Description	Qty
1	05-06-0136	GRD AUGER TAIL SHAFT	1
2	05-11-0452	BRG BLOCK TOP MNT UHMW VC	1
3	06-01-0069	BOLT .500-13 X 1.00 ZP GR5	3

U-BATCH™ TREATER

LIQUID DISTRIBUTION RING ASSEMBLY (13-05-0545)

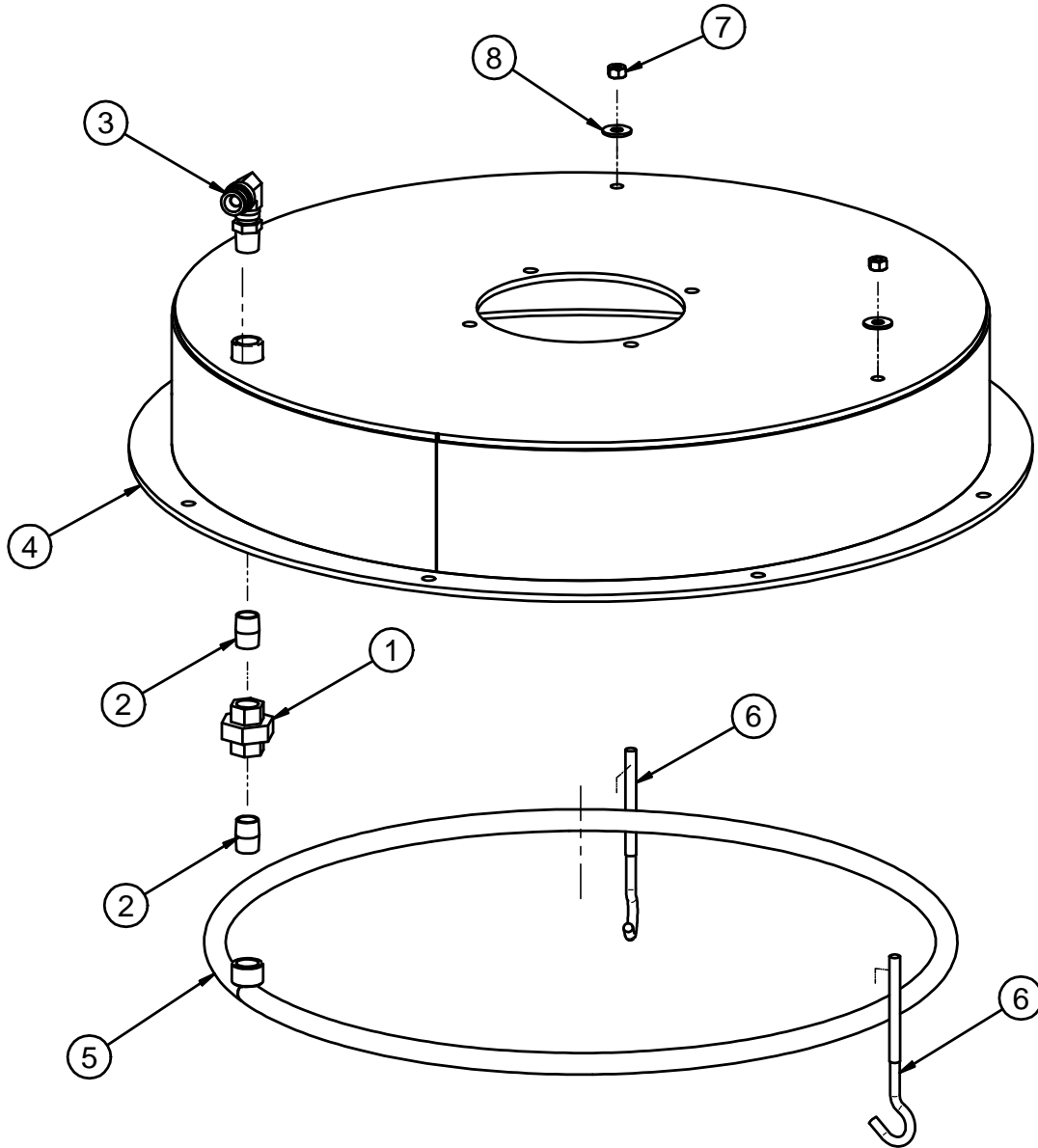

Item #	Part #	Description	Qty
1	02-05-0132	FTTG UNION .50 150PSI 304SS	1
2	02-07-0007	FTTG NIP .500NPTX1.125 TBE SS CLOSE	2
3	02-16-0050	FTTG PUSH 90DEG .625ODX.500 NPT ML	1
4	05-06-0135	WDMT CVR-BRG MNT AUGER TAIL	1
5	05-07-0886	WDMT LIQUID APLCTR BT68	1
6	06-01-0322	BOLT HOOK .375-16 X 7	2
7	06-02-0003	NUT FULL .375-16 ZP GR5	2
8	06-05-0004	WSHR FLAT .375 ZP	2

U-BATCH™ TREATER

U-BATCH™ TREATER BASE ASSEMBLY (13-11-0035)

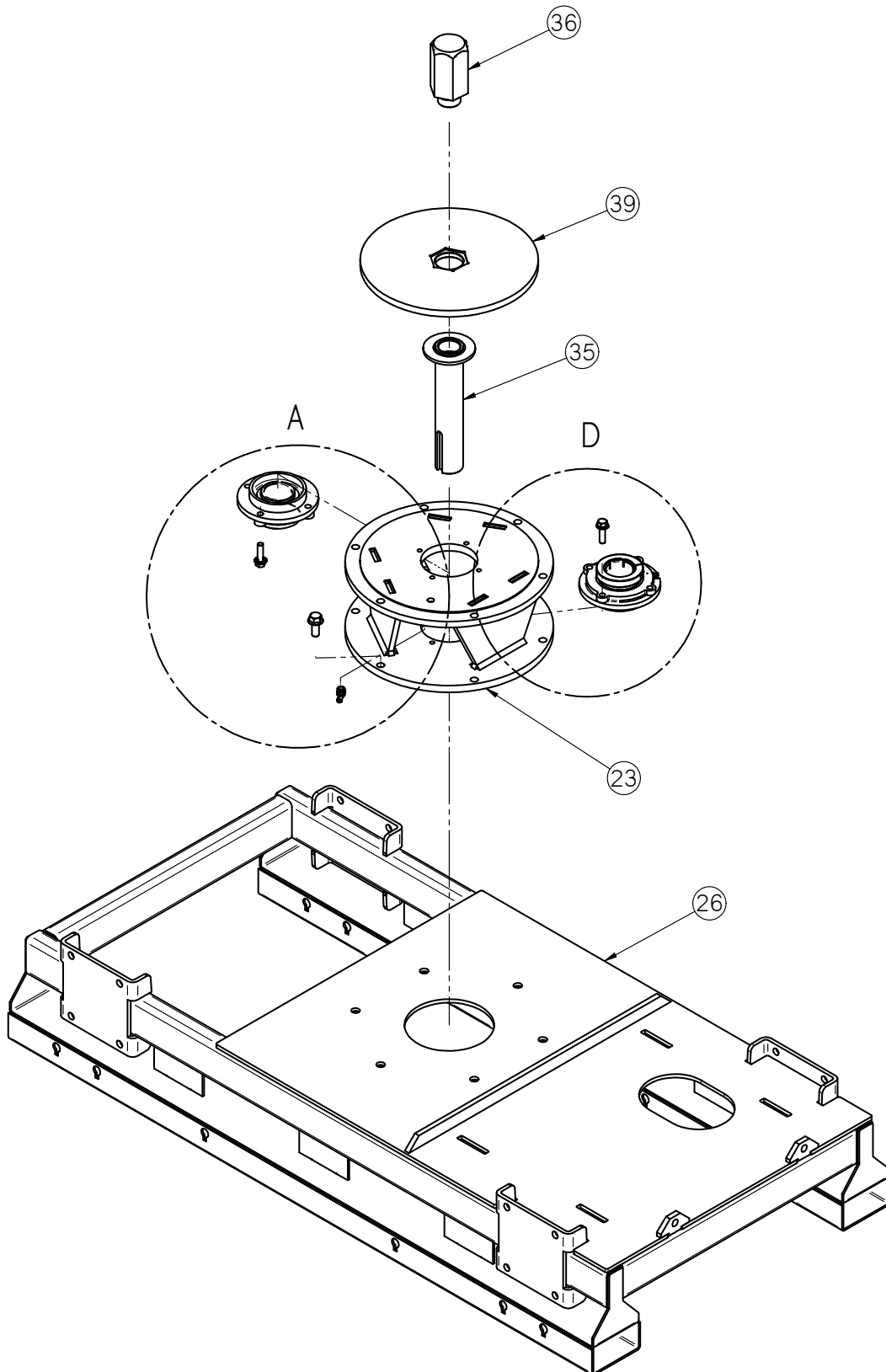

U-BATCH™ TREATER

U-BATCH™ TREATER BASE ASSEMBLY (13-11-0035)

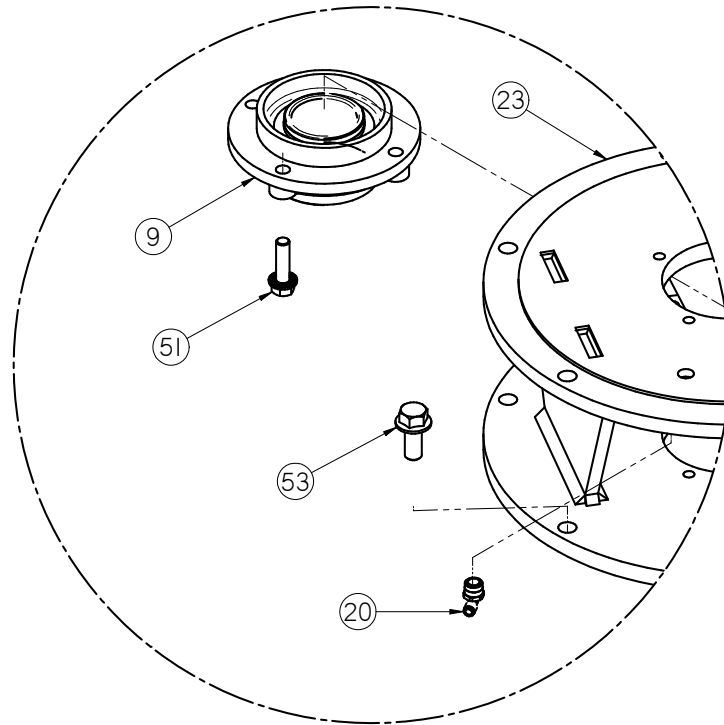

DETAIL A

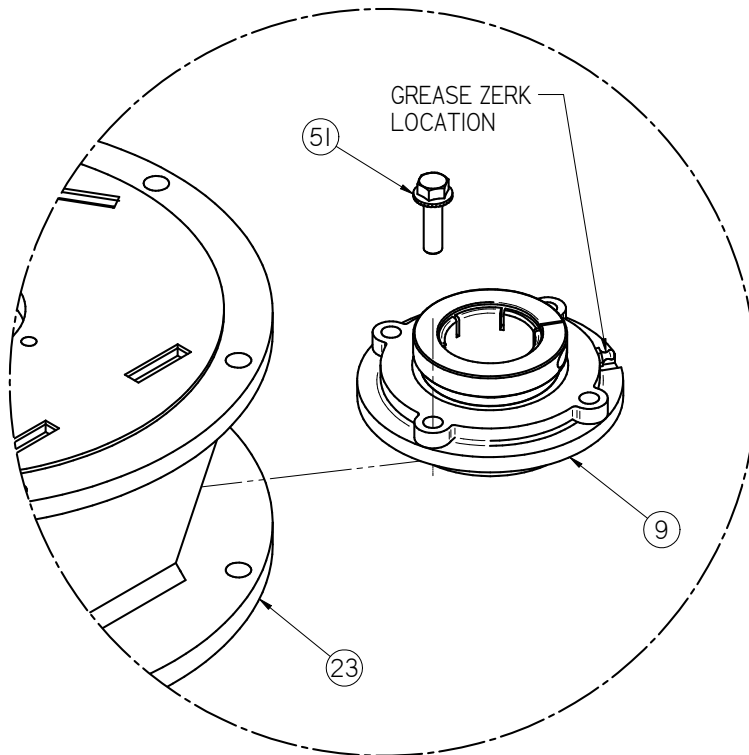

DETAIL D

U-BATCH™ TREATER

U-BATCH™ TREATER BASE ASSEMBLY (13-11-0035)

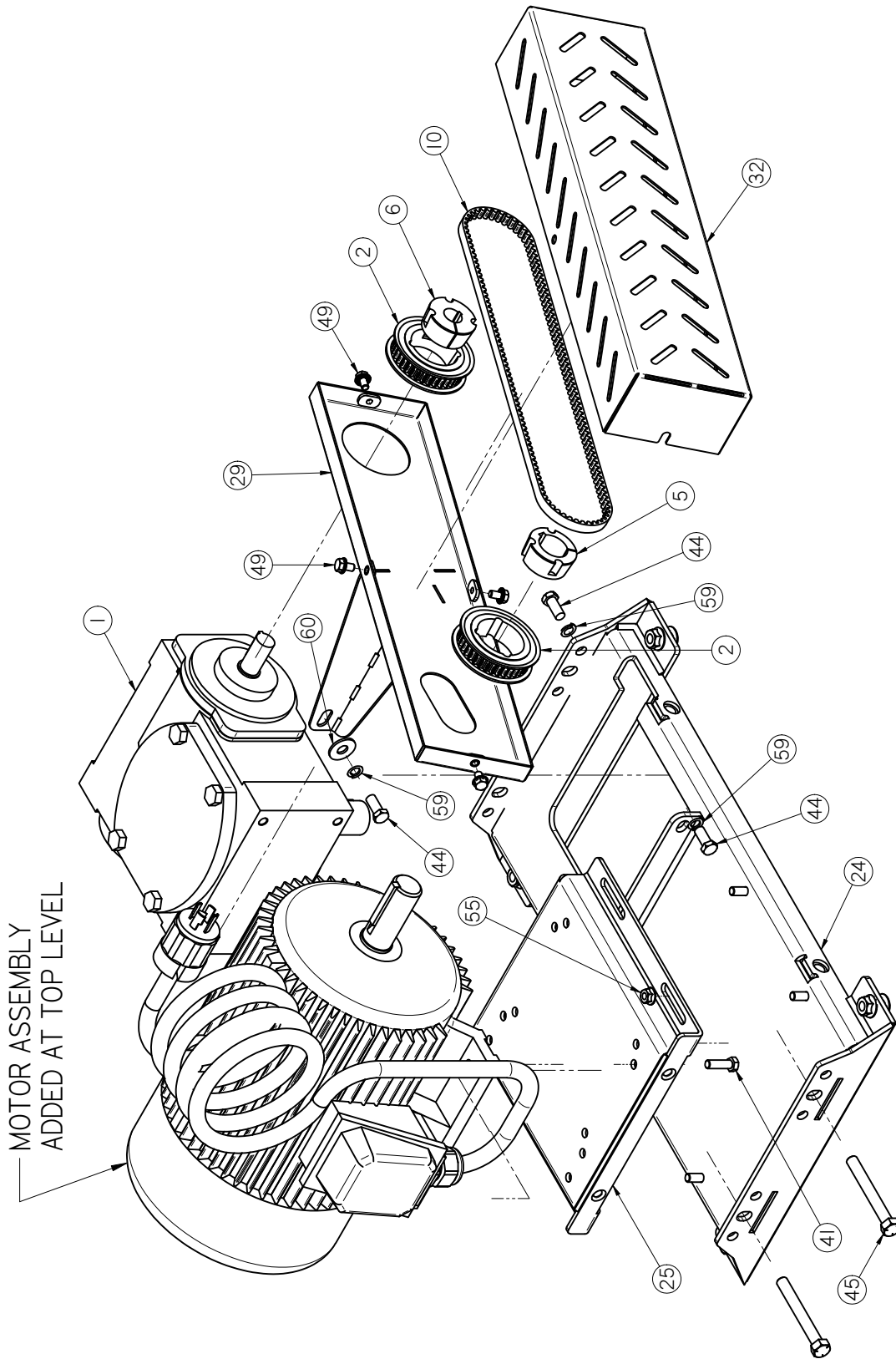

U-BATCH™ TREATER

U-BATCH™ TREATER BASE ASSEMBLY (13-11-0035)

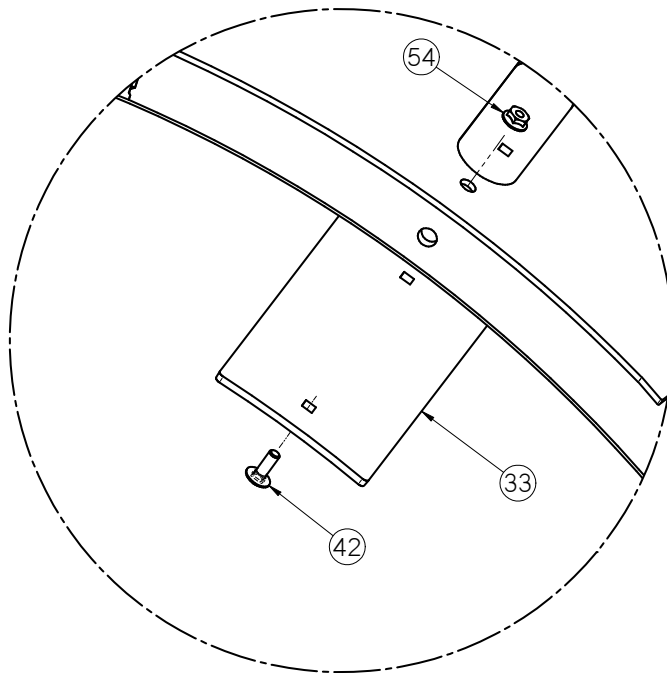
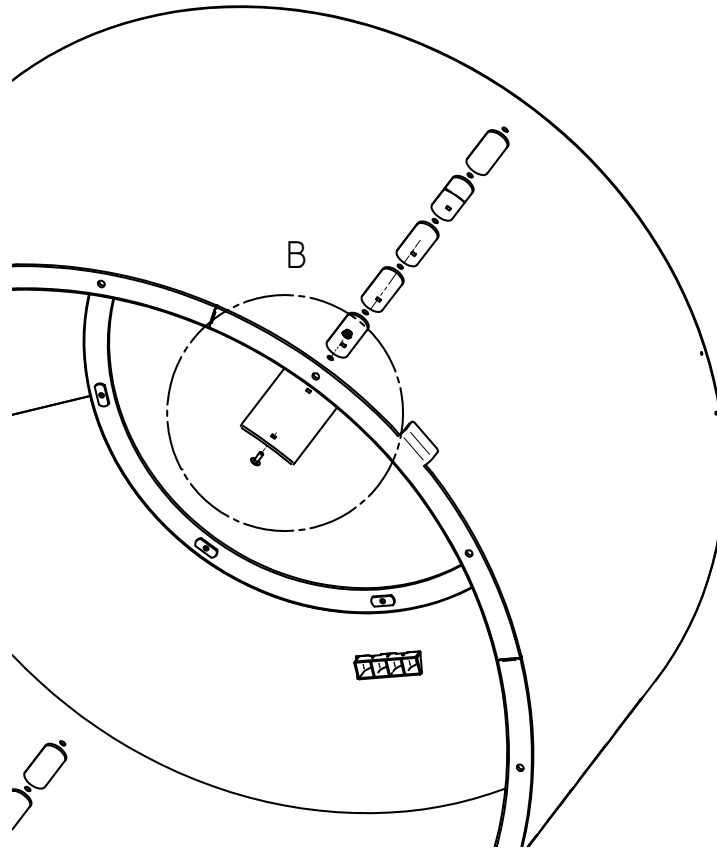

DETAIL B

U-BATCH™ TREATER
U-BATCH™ TREATER BASE ASSEMBLY (13-11-0035)

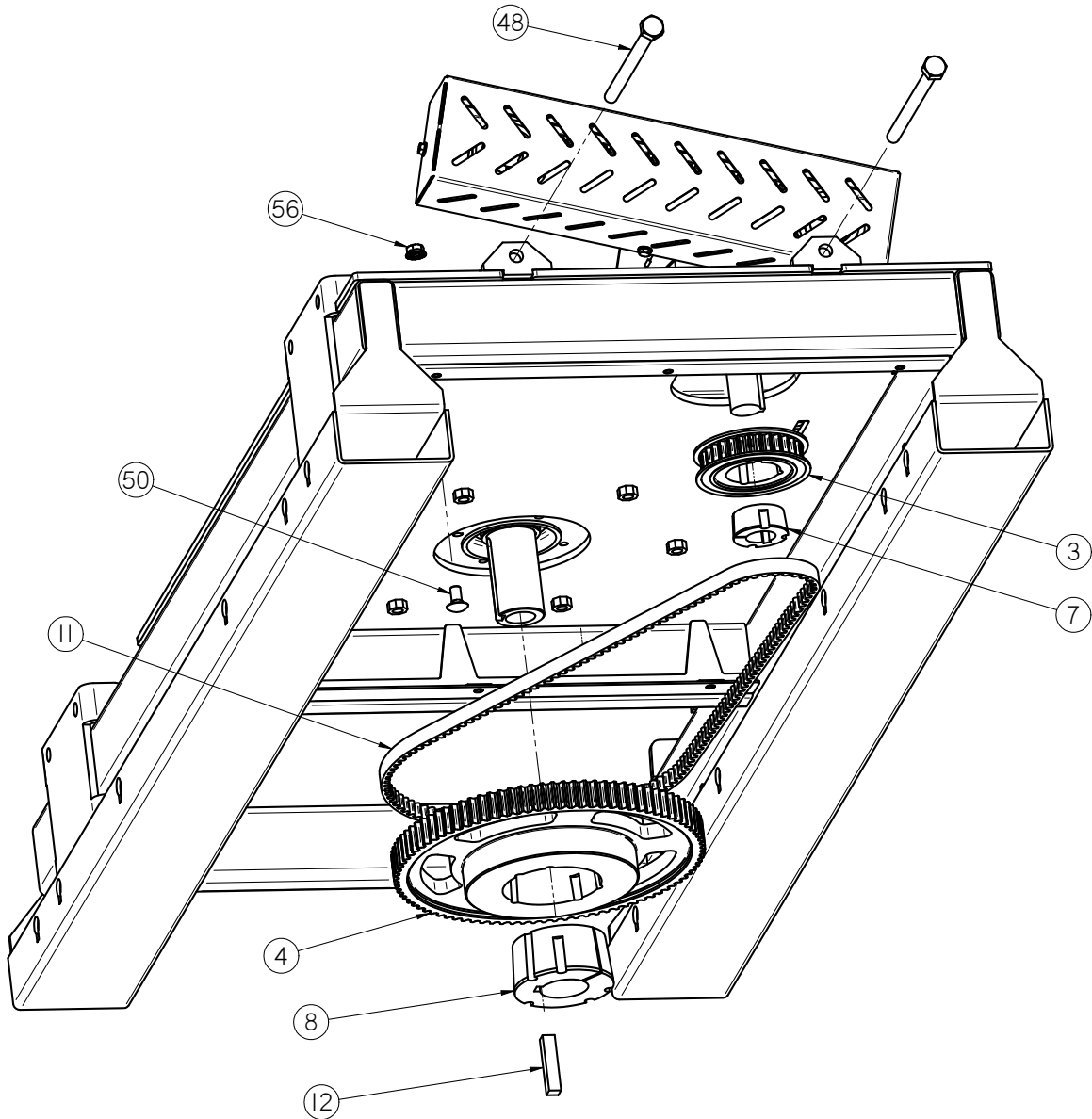

U-BATCH™ TREATER

U-BATCH™ TREATER BASE ASSEMBLY (13-11-0035)

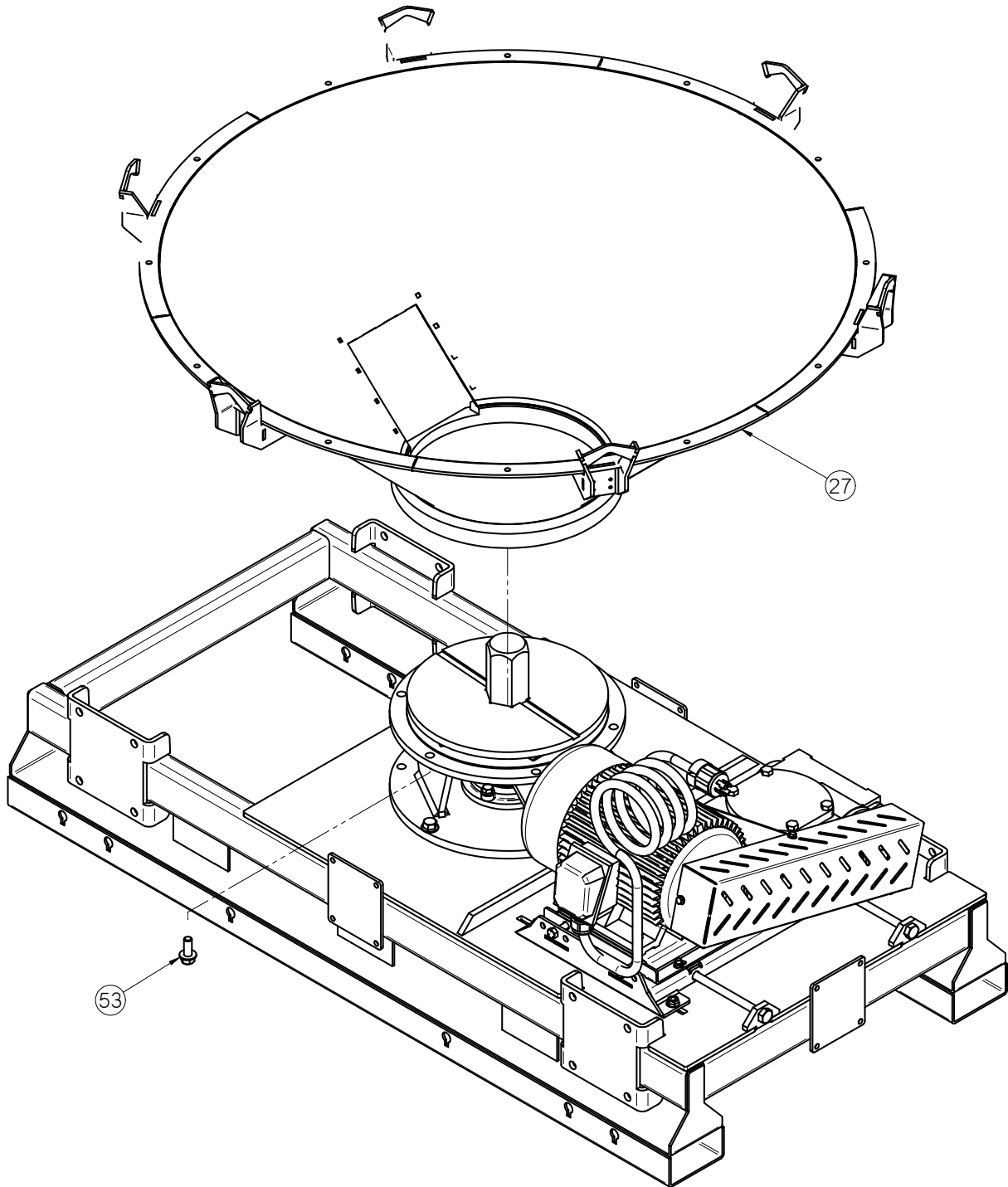

U-BATCH™ TREATER

U-BATCH™ TREATER BASE ASSEMBLY (13-11-0035)

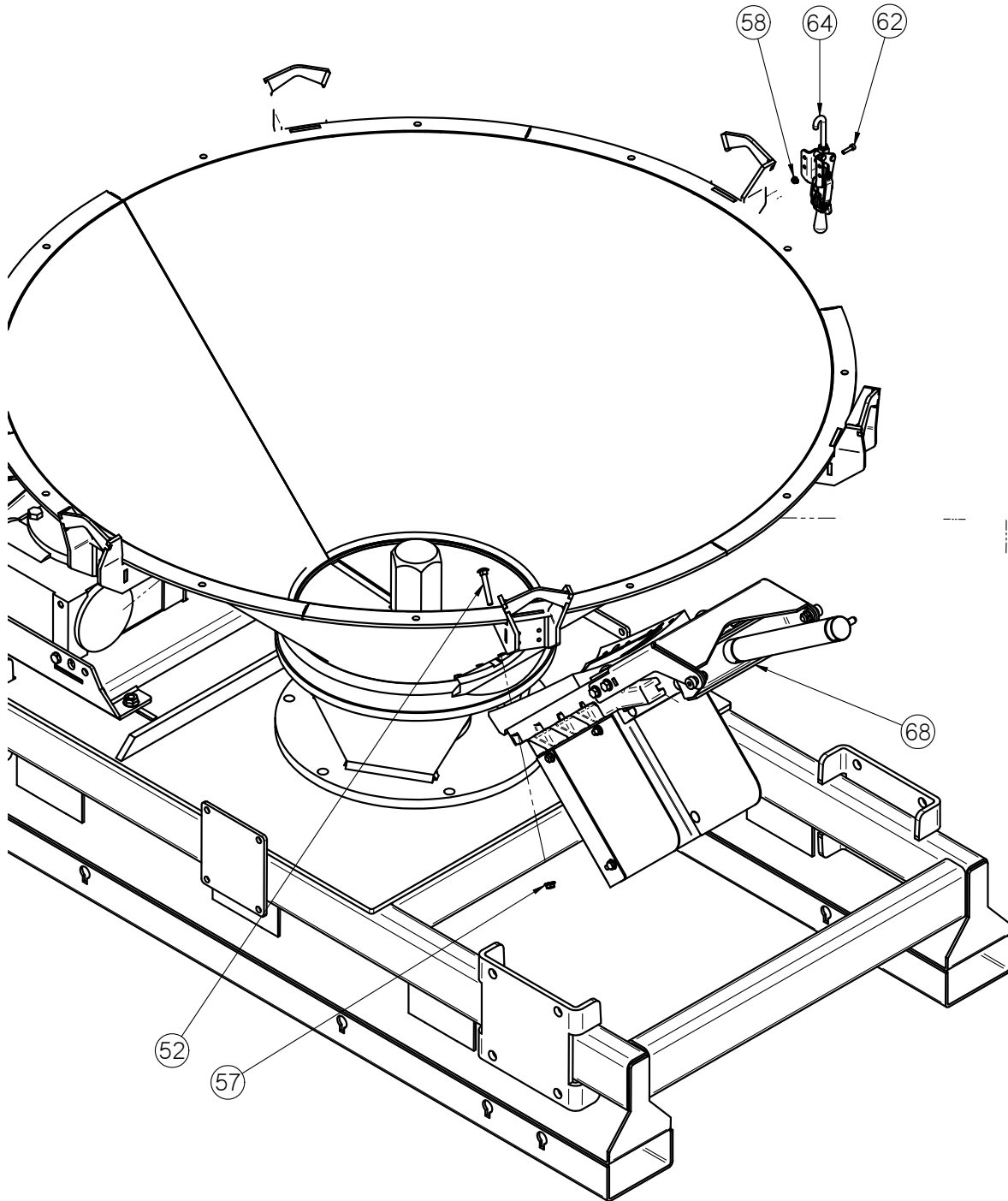

U-BATCH™ TREATER

U-BATCH™ TREATER BASE ASSEMBLY (13-11-0035)

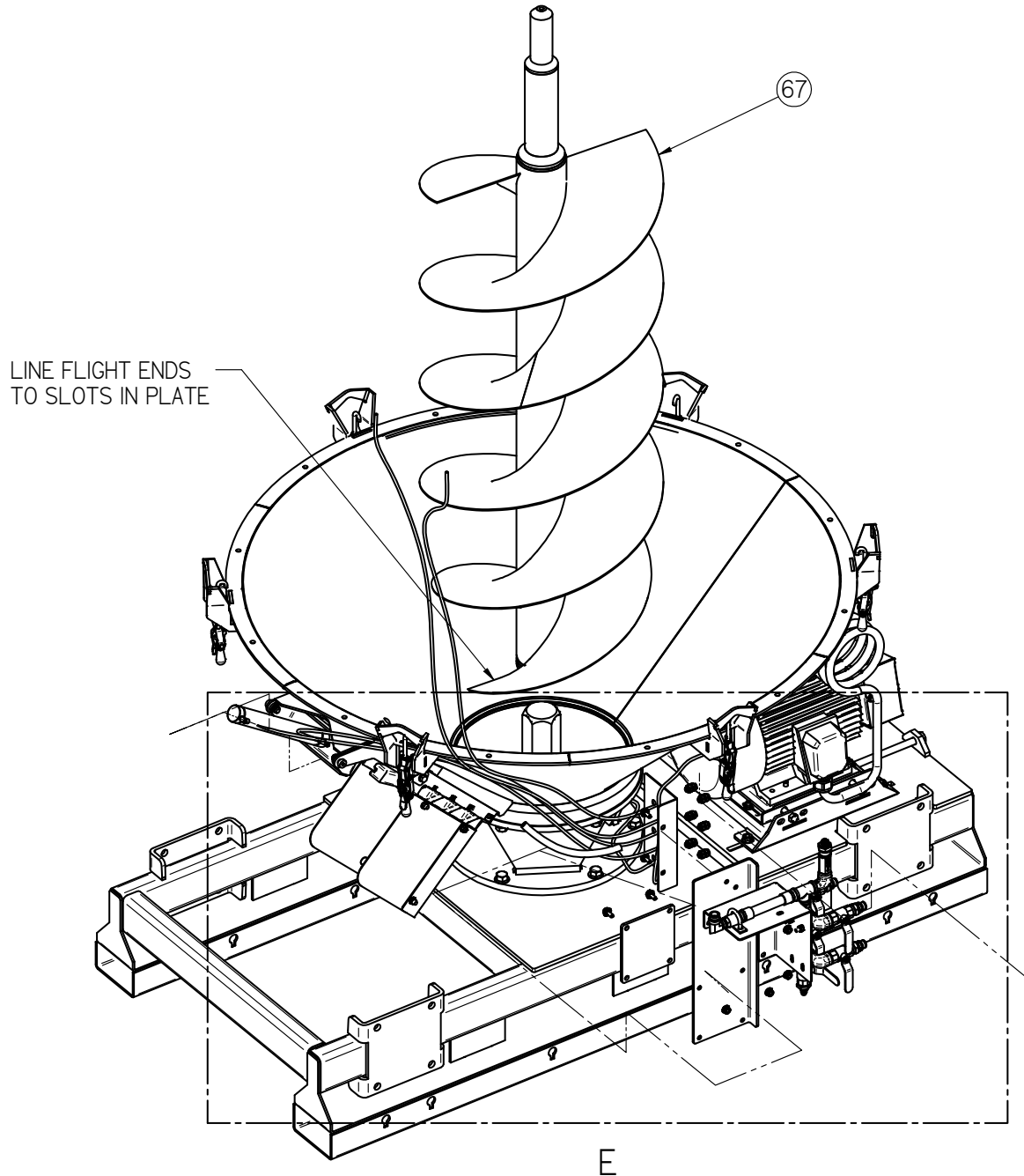

U-BATCH™ TREATER BASE ASSEMBLY (13-11-0035)

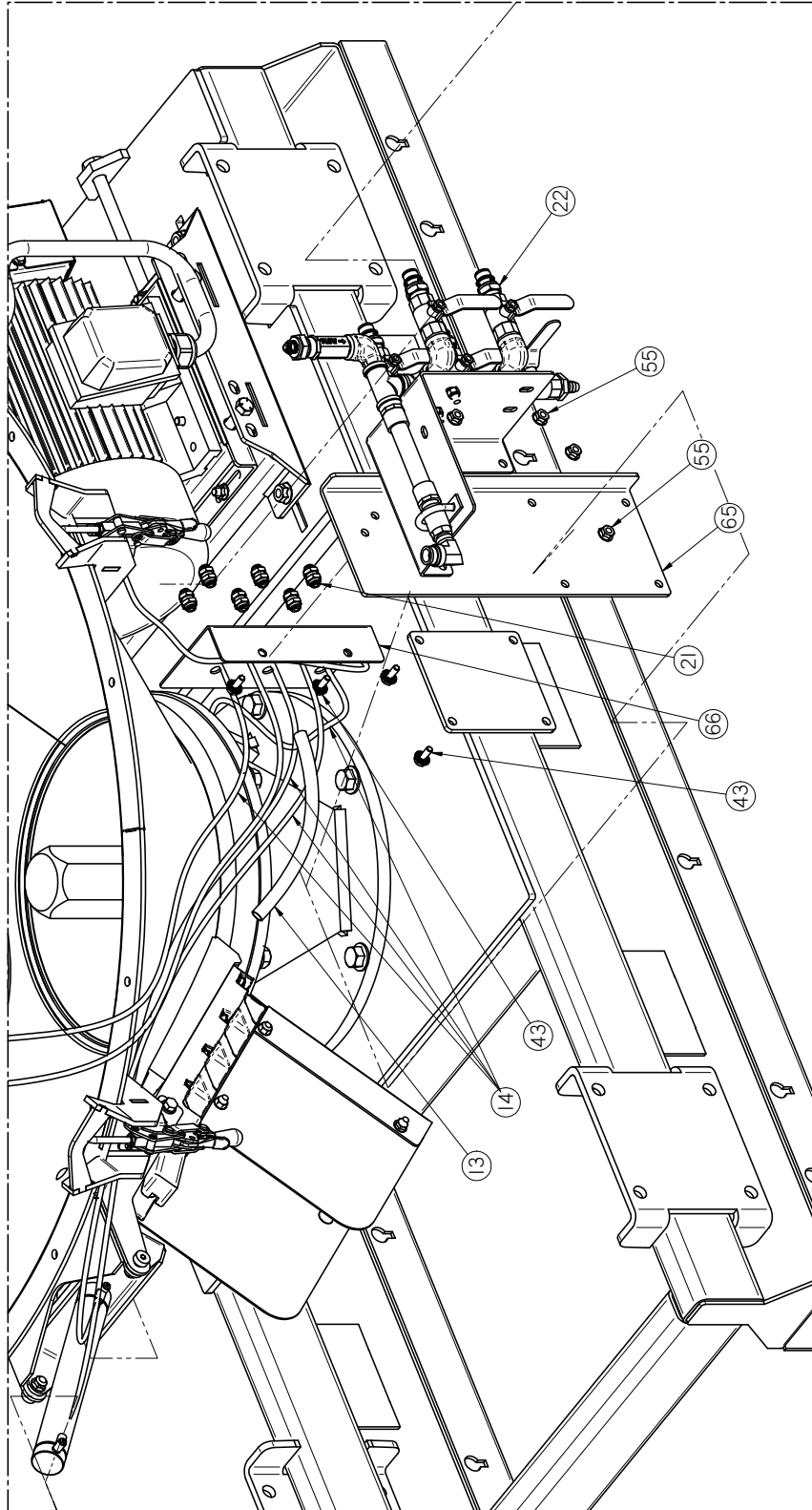

DETAIL E

U-BATCH™ TREATER

U-BATCH™ TREATER BASE ASSEMBLY (13-11-0035)

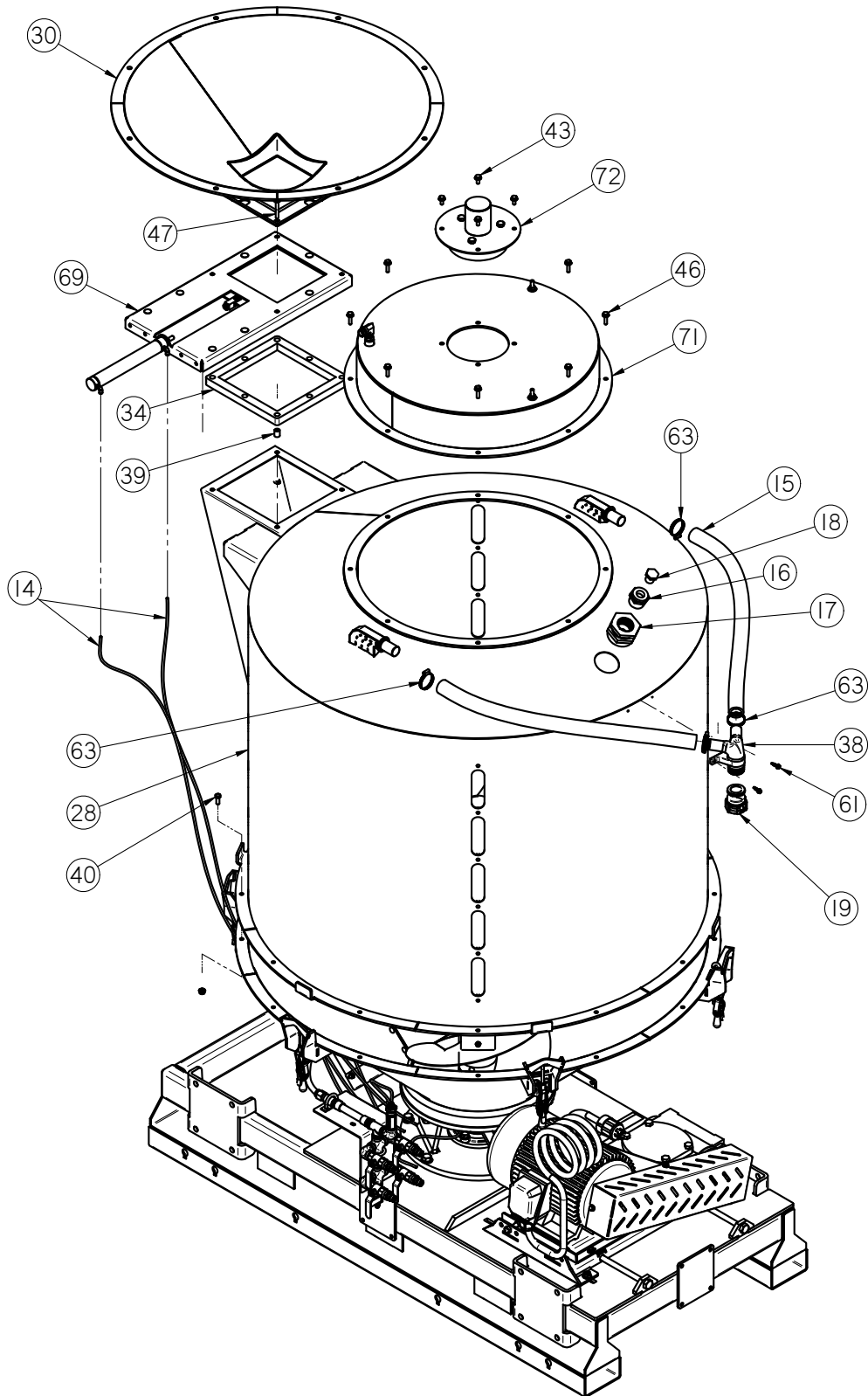

U-BATCH™ TREATER

U-BATCH™ TREATER BASE ASSEMBLY (13-11-0035)

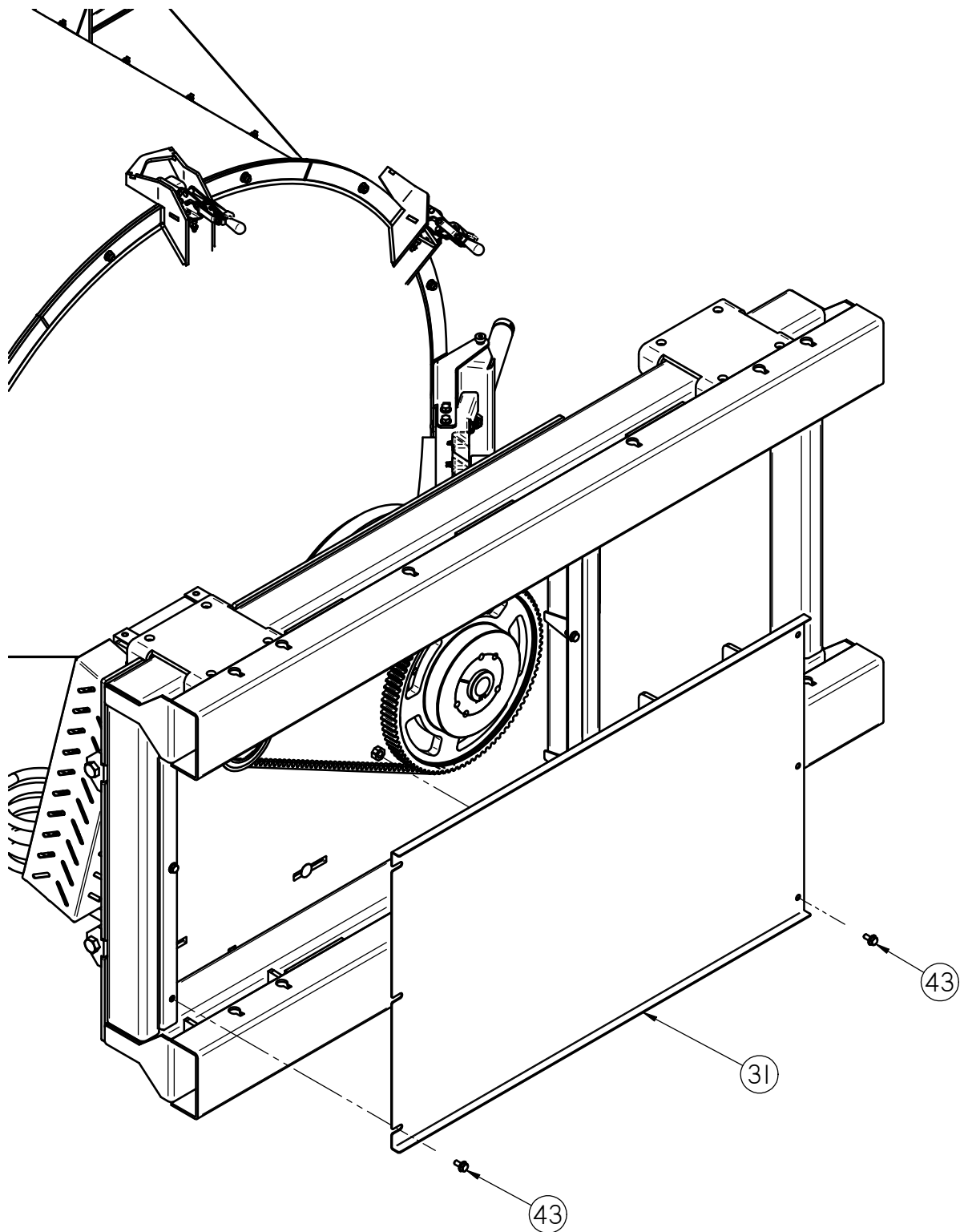

U-BATCH™ TREATER BASE ASSEMBLY (13-11-0035)

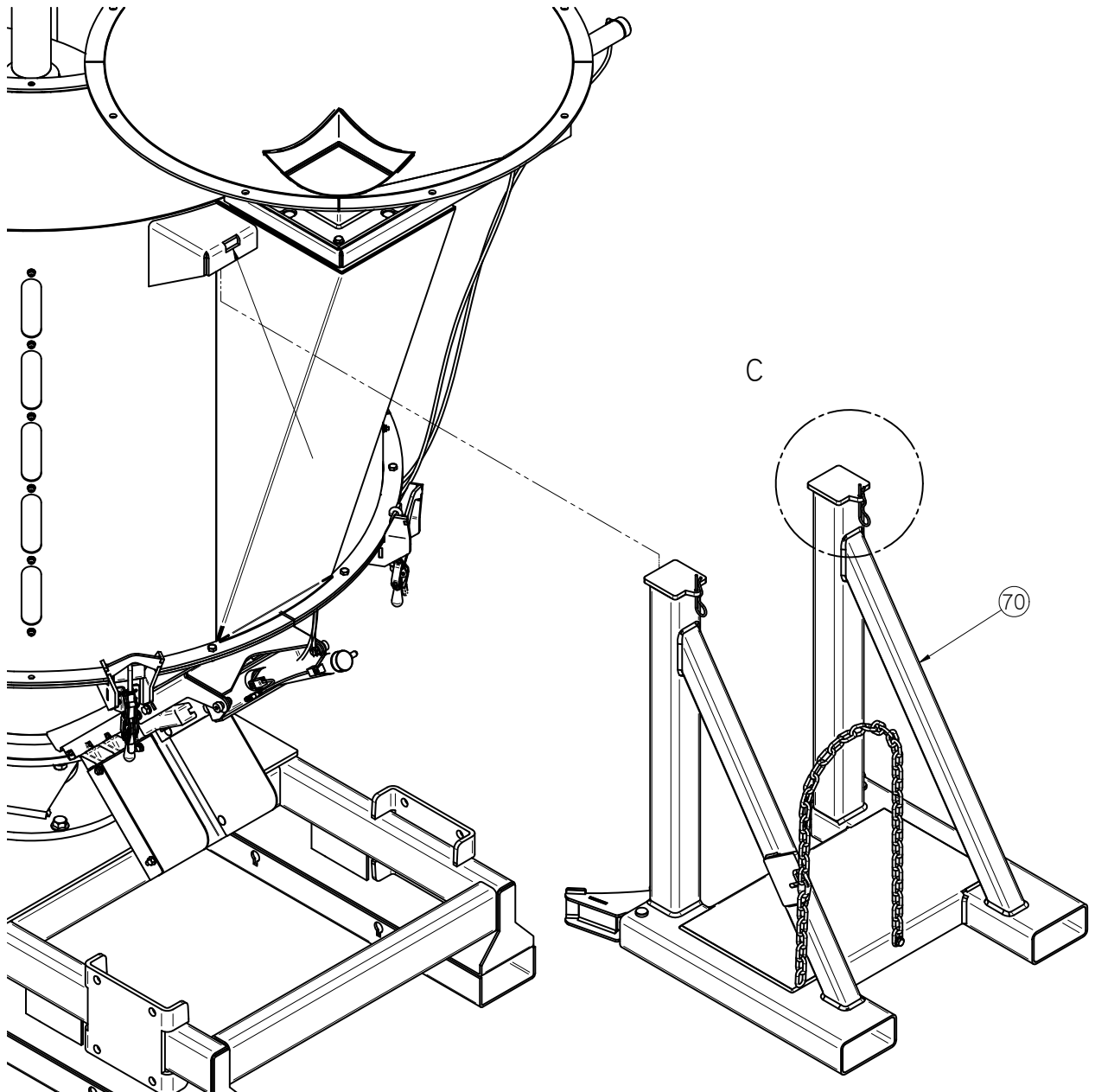

U-BATCH™ TREATER BASE ASSEMBLY (13-11-0035)

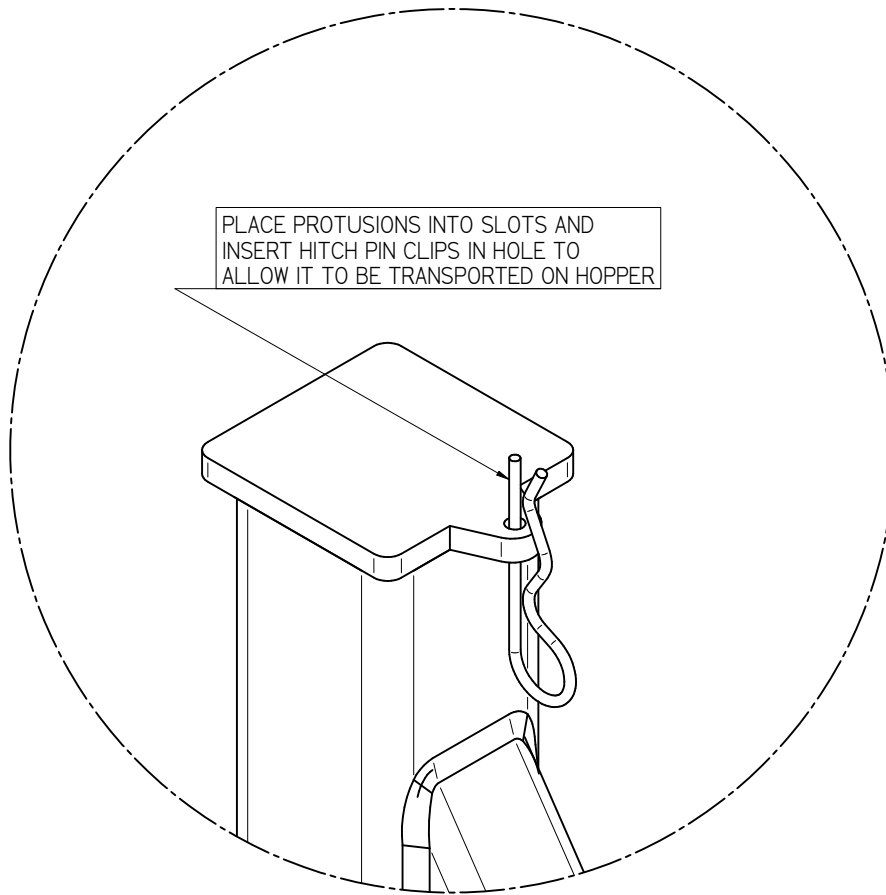

DETAIL C

U-BATCH™ TREATER

U-BATCH™ TREATER BASE ASSEMBLY (13-11-0035)

Item #	Part #	Description	Qty
1	01-01-0218	GBOX RA 5:1 GR 1.50 OUT .875 IN	1
2	01-02-0123	PLLY GBLT 8MX-34S-12 TL 1610	2
3	01-02-0124	PLLY GBLT 14MX-30S-20 TL 2012	1
4	01-02-0125	PLLY GBLT 14MX-90S-20 TL 3525	1
5	01-02-0126	BUSH 1.375 BORE TYPE TL 1610	1
6	01-02-0127	BUSH 0.875 BORE TYPE TL 1610	1
7	01-02-0128	BUSH 1.500 BORE TYPE TL 2012	1
8	01-02-0129	BUSH 2.437 BORE TYPE TL 3525	1
9	01-03-0065	BRG FLG 2.4375ID 4BOLT 6IN PLTD	2
10	01-04-0077	GBLT 8MGT-1120-12	1
11	01-04-0078	GBLT 14MGT-2100-20	1
12	01-10-0010	KEY .625 X 3.00 CS UNDERSIZE	1
13	02-03-0034	TBG .625 OD POLYE COMP - FEET	1
14	02-03-0051	TBG .250 OD NYL BLK - FEET	25
15	02-03-0070	HOSE RNT 1.250 CLEAR	2
16	02-04-0034	FTTG BUSH 1.50NPT X .750NPT PPE	1
17	02-05-0107	FTTG 1.5NPT DBL THD PVC BULKHEAD	1
18	02-14-0021	FTTG PLUG HH .750 NPT PPE BLK	1
19	02-15-0060	FTTG CPLG CAM LVR 1.5ML X 1.50FNPT	1
20	02-16-0049	FTTG PUSH 90 DEG .25 OD X .375 NPT	1
21	02-16-0059	FTTG PUSH BLKHD UNION .250 TUBE	6
22	04-03-0289	ASSY STTC MXR & VLVS BATCH TRTR 90D	1
23	05-03-1515	WDMT HSG BRG VC	1
24	05-03-1569	WDMT FR GBOX DRV	1
25	05-03-1570	WDMT FR MTR MNT	1
26	05-03-1571	WDMT FR BASE 4 LEG VC	1
27	05-03-1664	WDMT HOPP CONE SIDE DSCHG VC	1
28	05-03-1665	WDMT HOPP 54IN TOP VC	1
29	05-06-0113	GRD BACK GBOX DRV	1
30	05-07-0864	WDMT CONE HOPP BT	1
31	05-10-4349	PLT GRD AUGER DRV VC CS	1
32	05-10-4350	PLT GRD GBOX DRV VC CS	1
33	05-10-4418	CVR CLEAR VP 5 SLOT	4
34	05-10-4441	SEAL FOAM 1IN BT INLET	1
35	05-11-0462	SHAFT DRV AUGER BT68	1



U-BATCH™ TREATER

U-BATCH™ TREATER BASE ASSEMBLY (13-11-0035)

Item #	Part #	Description	Qty
36	05-11-0463	SPUD HEX DRV BT68	1
37	05-11-0466	TEE 90DEG 1.50NPT X 1.25 X 1.25 ABS	1
38	05-11-0474	SPCR .625OD X .406ID X .812LG	4
39	05-11-0513	PLT END BTM LIVE HLLW CS NO GROOVE	1
40	06-01-0016	BOLT .375-16 X 1.00 ZP GR5	11
41	06-01-0053	BOLT .375-16 X 1.25 ZP GR5	4
42	06-01-0122	BOLT, CARRIAGE, .250-20x.75 G5 ZP	24
43	06-01-0124	BOLT FLG .375-16 X .750 ZP GR5	17
44	06-01-0132	BOLT,.4375-14 G5 ZP 1.00	6
45	06-01-0157	BOLT, .500-13 X 4" UNC ZP GRADE 5 fth	2
46	06-01-0189	BOLT FLG .375-16 X 1.250 ZP GR5	8
47	06-01-0204	BOLT FLG .375-16 X 2.50 ZP GR5 FTH	4
48	06-01-0249	BOLT .625-11 X 9.00 ZP GR5 FTH	2
49	06-01-0261	BOLT FLG .3125-18 X .500 ZP GR5	4
50	06-01-0270	BOLT CRG .500-13 X 1.00 ZP GR5	4
51	06-01-0271	BOLT FLG .500-13 X 1.750 ZP	8
52	06-01-0289	BOLT CRG .313-18 X 2.25 ZP GR5	8
53	06-01-0292	BOLT FLG .625-11 X 1.500 GR5 ZP	12
54	06-03-0013	NUT,LOCK, FLG .250-20 ZP SERRATTED	24
55	06-03-0014	NUT LOCK FLG .375-16 ZP GR5	23
56	06-03-0015	NUT LOCK FLG .500-13 ZP GR5	4
57	06-03-0019	NUT LOCK FLG .3125-18 ZP GR5	8
58	06-03-0031	NUT LOCK FLG M5-0.8 GR8.8	24
59	06-04-0011	WASHER, .4375 LOCK ZP	6
60	06-05-0020	WASHER, .4375 FLAT ZP	2
61	06-06-0037	SCRW SDST .250-14 X 1.000 HH ZP	2
62	06-06-0083	SCRW SH M5-0.8 X 20MM BO	24
63	06-07-0019	HOSE CLAMP, 1.00" to 2.00"	4
64	06-07-0041	CLMP DESTACO MILD STEEL 3051-R	6
65	104AE2	PLT MNT STTC MIXER	1
66	104AE7	PLT BT AIR BLKHD	1
67	11-05-0031	AUGER WDMT RH DF 3.0IN DRV FLSH END	1
68	12-04-0031	ASSY SLGT DSCHG 7IN BT 3DP	1
69	12-04-0038	ASSY SLD GATE BT INLET 8IN	1
70	13-05-0463	BT HOPP LIFT	1

U-BATCH™ TREATER

U-BATCH™ TREATER BASE ASSEMBLY (13-11-0035)

Item #	Part #	Description	Qty
71	13-05-0545	ASSY TOP CAP W LQ RG BATCH TRTR	1
72	13-05-0546	ASSY TOP CAP BRG BT	1

U-BATCH™ TREATER
HYDRAULIC LEG ASSEMBLY (05-05-0138)

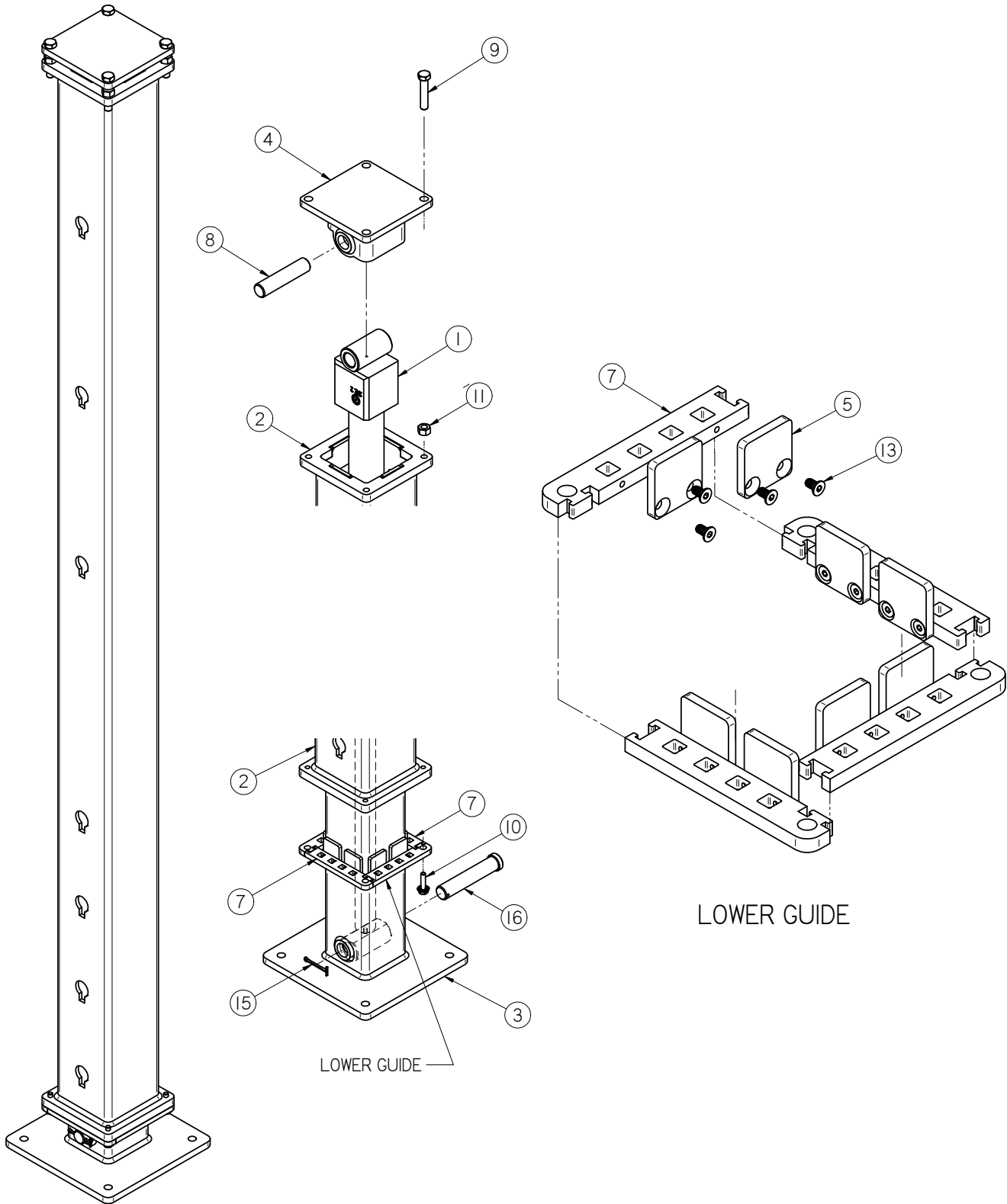

HYDRAULIC LEG ASSEMBLY (05-05-0138)

Item #	Part #	Description	Qty
1	03-17-0116	CYL HYD WELD 66IN STROKE 2IN ID*	1
2	05-05-0140	WDMT OUTER LEG BT HYD 66.0IN STROKE	1
3	05-05-0141	WDMT INNER LEG BT HYD 66.0IN STROKE	1
4	05-05-0142	WDMT MNT CYL BASE BT HYD	1
5	05-10-4456	GUIDE UHMW LEG HYD BT	8
6	05-10-4541	GUIDE UHMW LEG HYD BT	8
7	05-11-0469	BRKT MNT TUBE GUIDES	4
8	05-11-0482	PIN 1.000 X 4.437 CS	1
9	06-01-0125	BOLT .500-13 X 2.50 ZP GR5 FTH	4
10	06-01-0189	BOLT FLG .375-16 X 1.250 ZP GR5	4
11	06-02-0004	NUT FULL .500-13 ZP GR5	4
12	06-02-0043	NUT,LOCK, #10-24 ZP NYLON INSERT	16
13	06-06-0095	SCRW MACH 10-24 X.375 FLHD SCKT BO	16
14	06-06-0103	SCRW MACH 10-24 X.75 FLHD SCKT BO	16
15	06-09-0023	.188 X 2.00 ZP COTTER PIN	1
16	06-09-0108	PIN CLVS 1.00 X 5.0 ZP	1

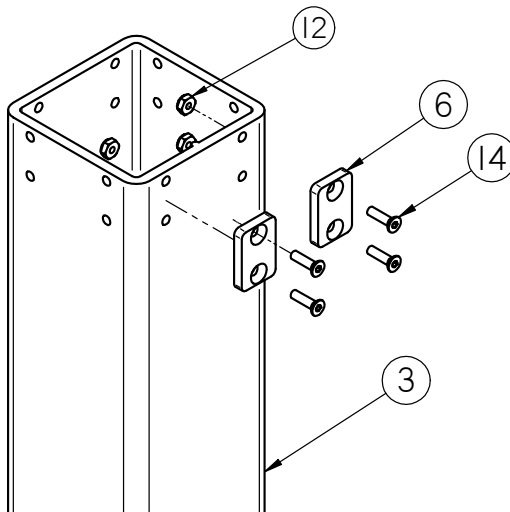

TOP INSIDE LEG

U-BATCH™ TREATER
HYDRAULIC LIFT ASSEMBLY (05-05-0145)

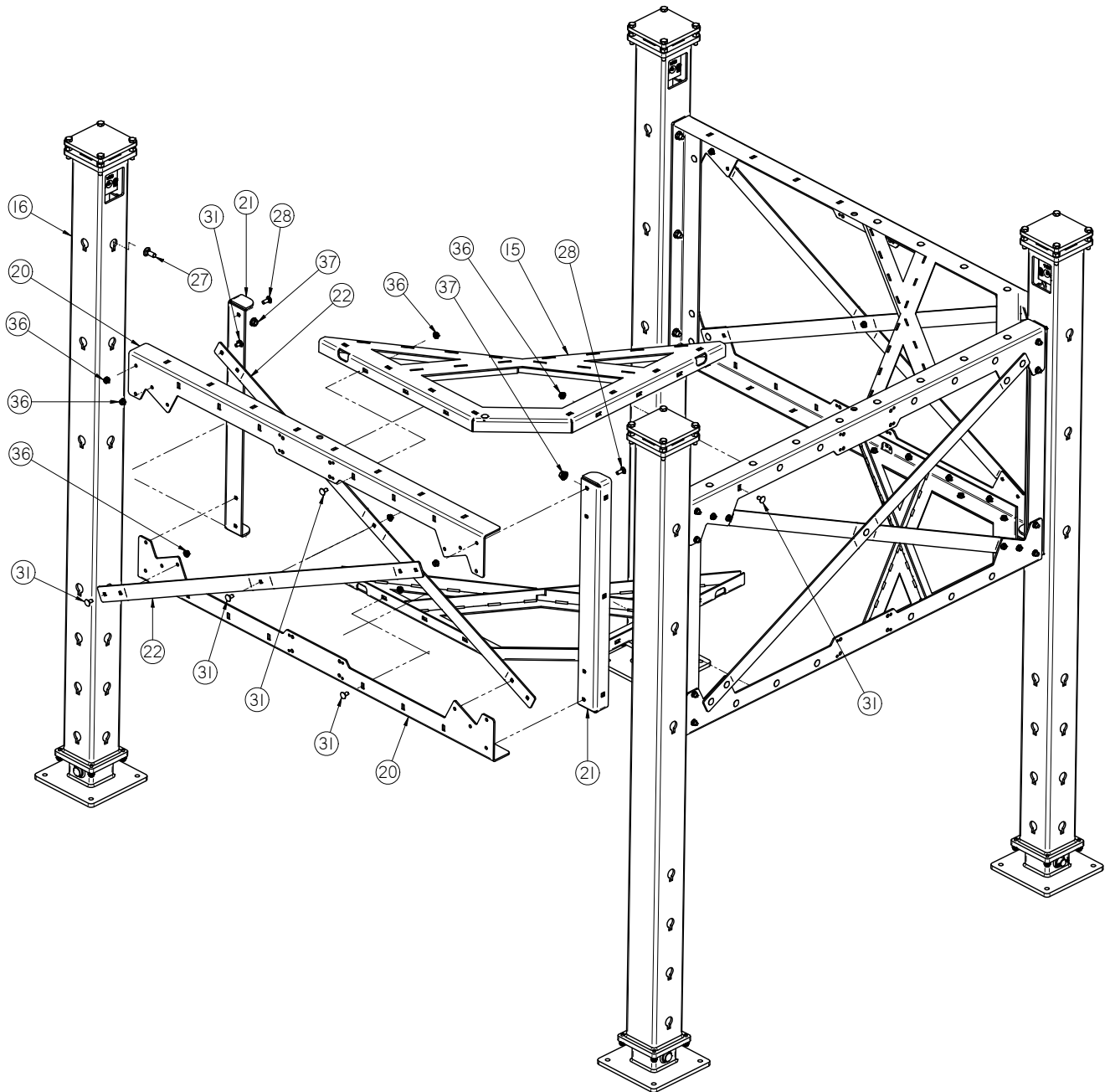

U-BATCH™ TREATER
HYDRAULIC LIFT ASSEMBLY (05-05-0145)

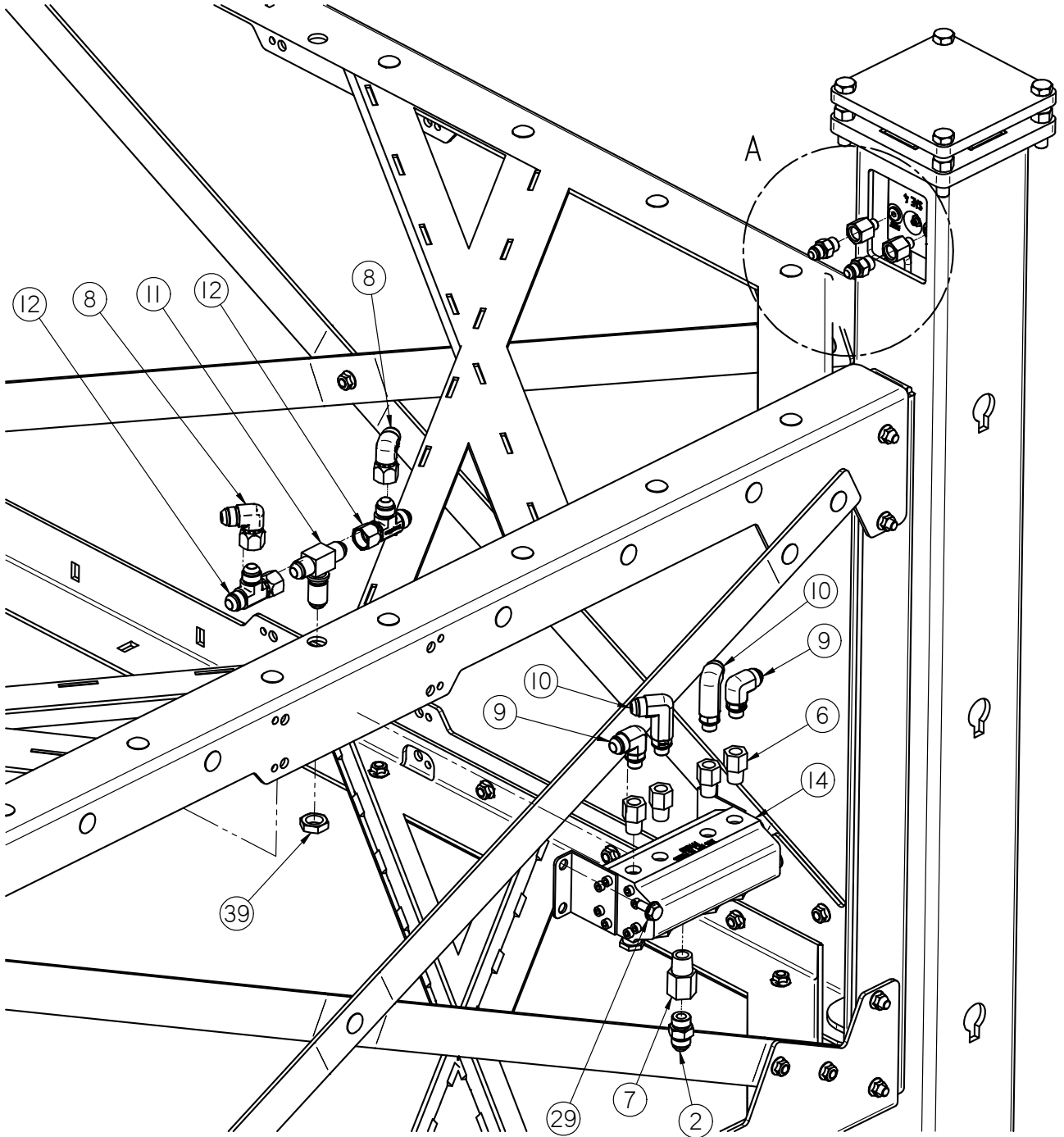

HYDRAULIC LIFT ASSEMBLY (05-05-0145)

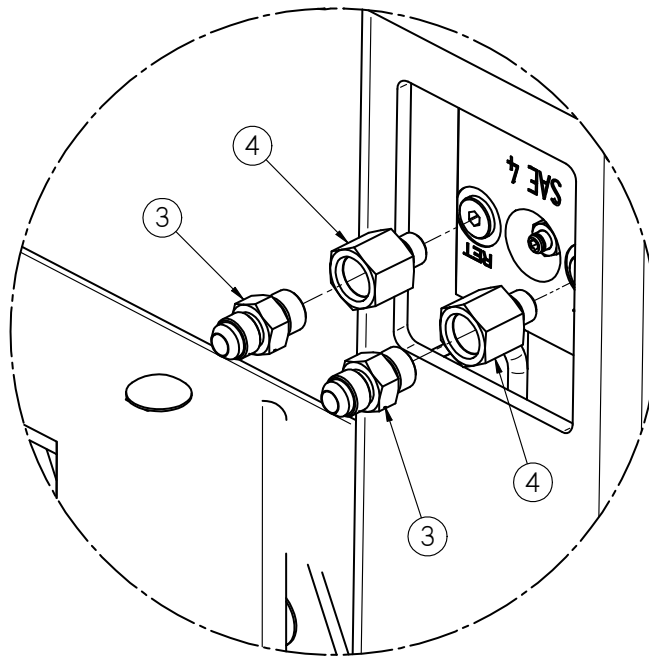
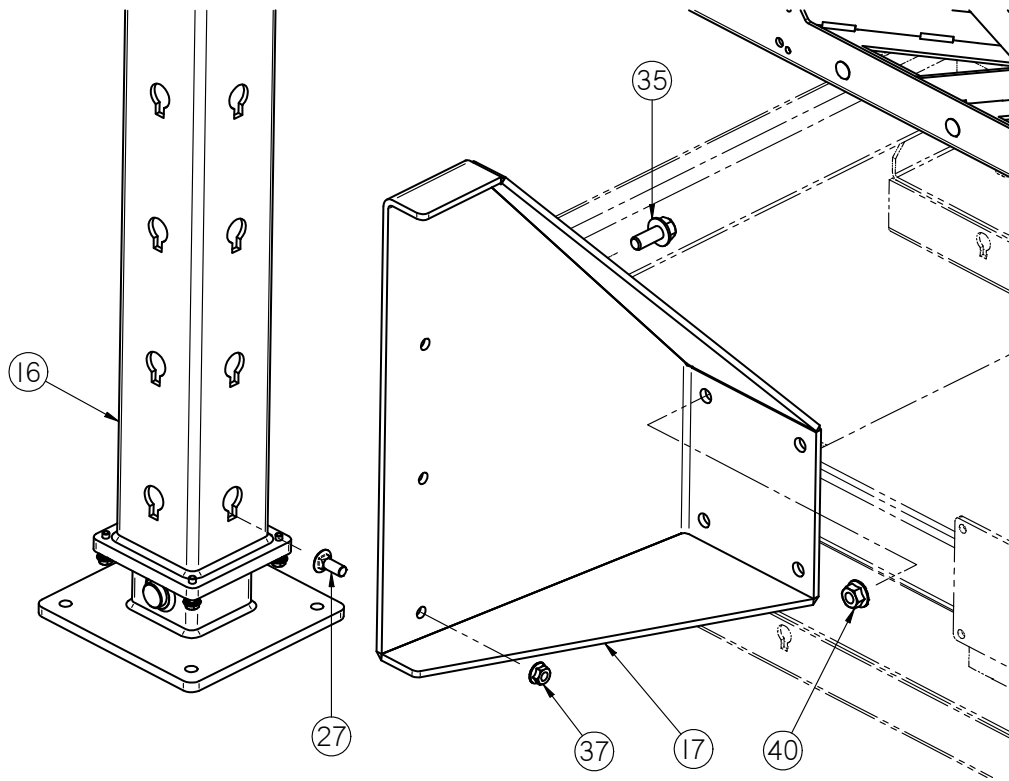

U-BATCH™ TREATER
HYDRAULIC LIFT ASSEMBLY (05-05-0145)

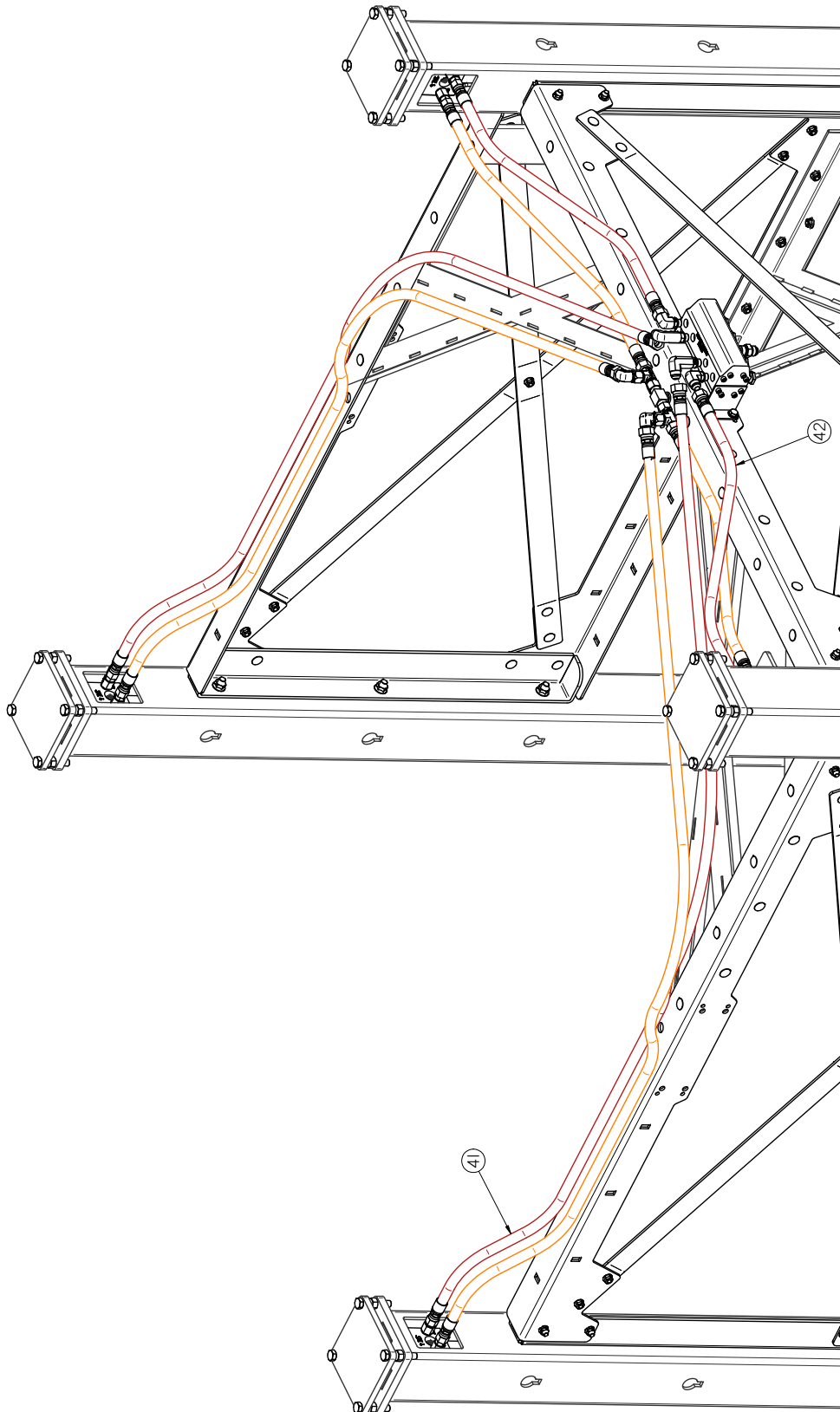

RED LINE FOR LIFTING
ORANGE LINES FOR LOWERING

U-BATCH™ TREATER
HYDRAULIC LIFT ASSEMBLY (05-05-0145)

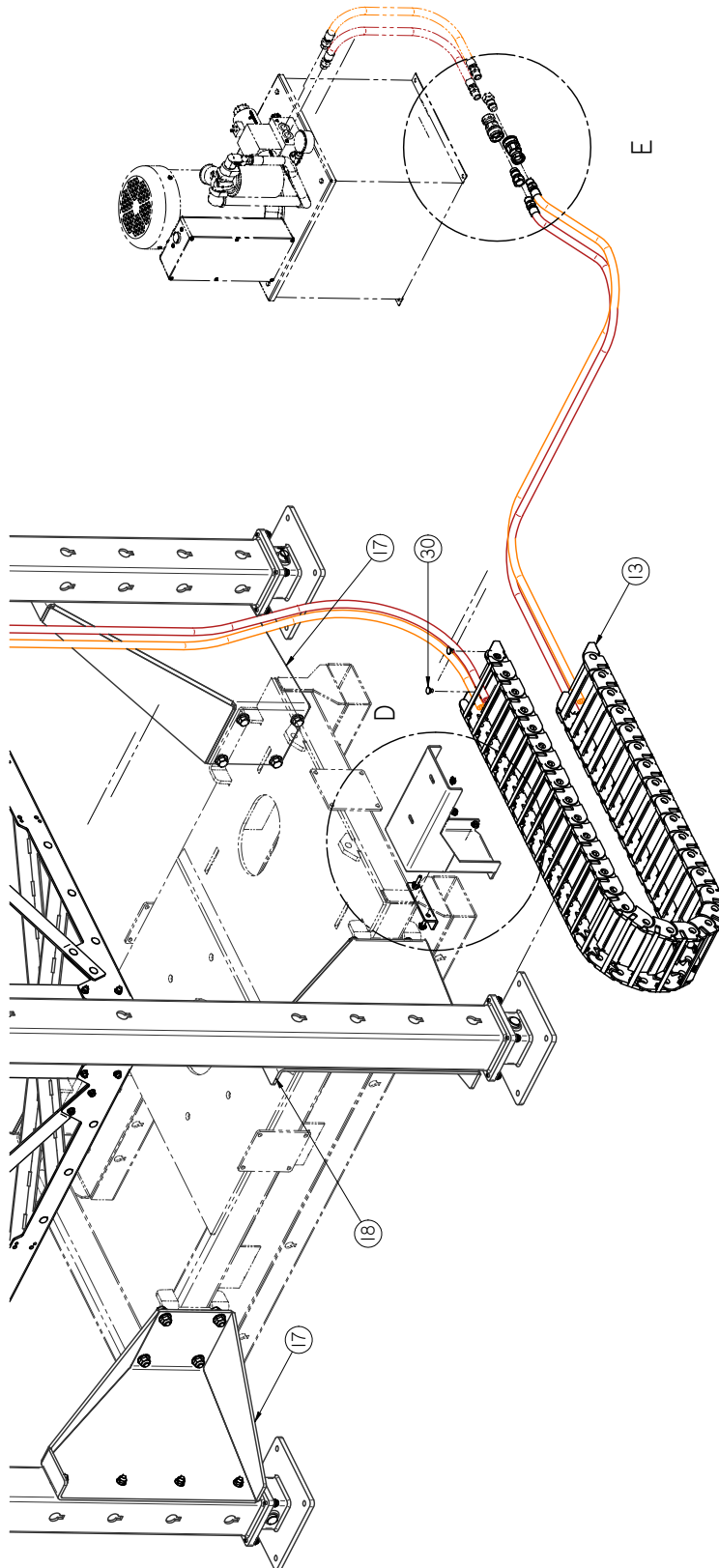

U-BATCH™ TREATER
HYDRAULIC LIFT ASSEMBLY (05-05-0145)

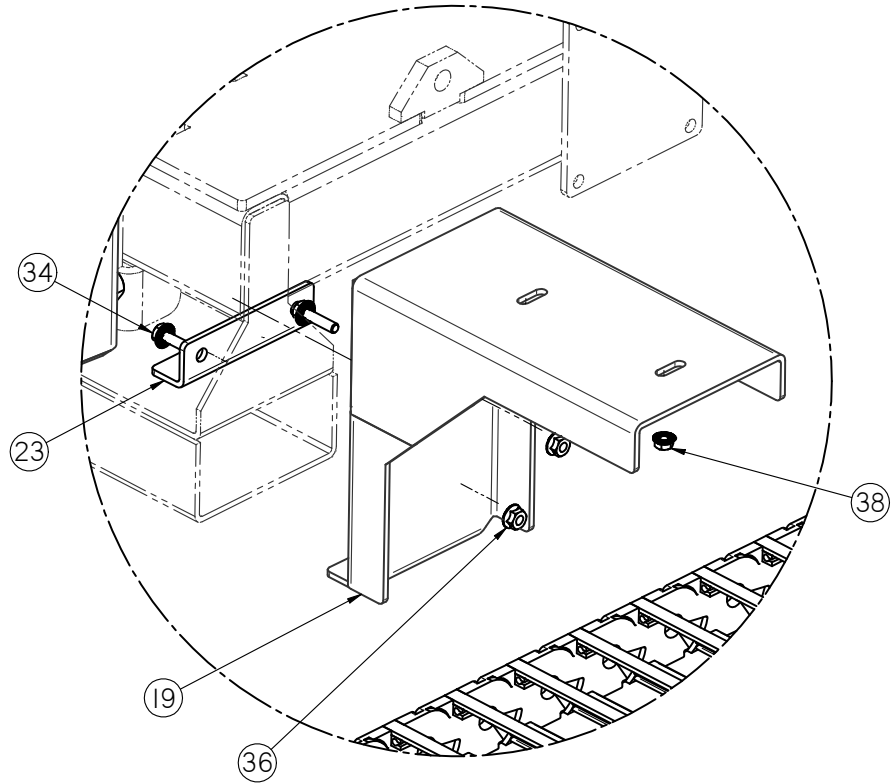

DETAIL D

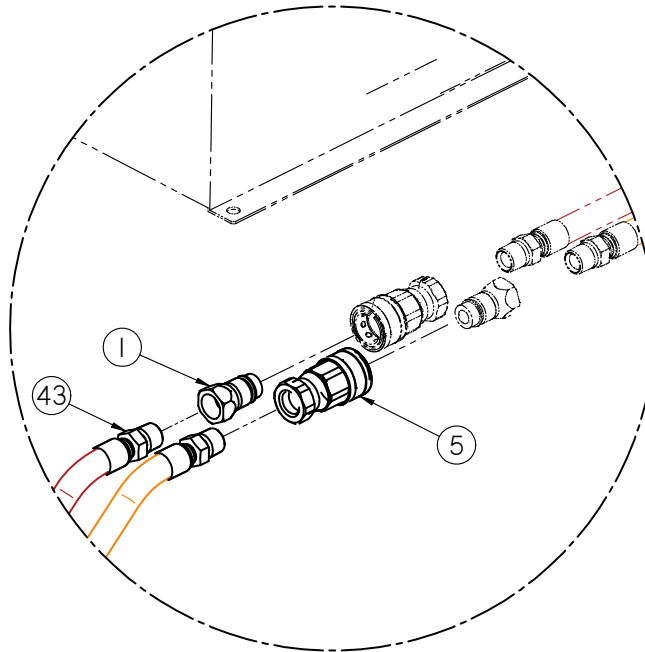

DETAIL E

U-BATCH™ TREATER
HYDRAULIC LIFT ASSEMBLY (05-05-0145)

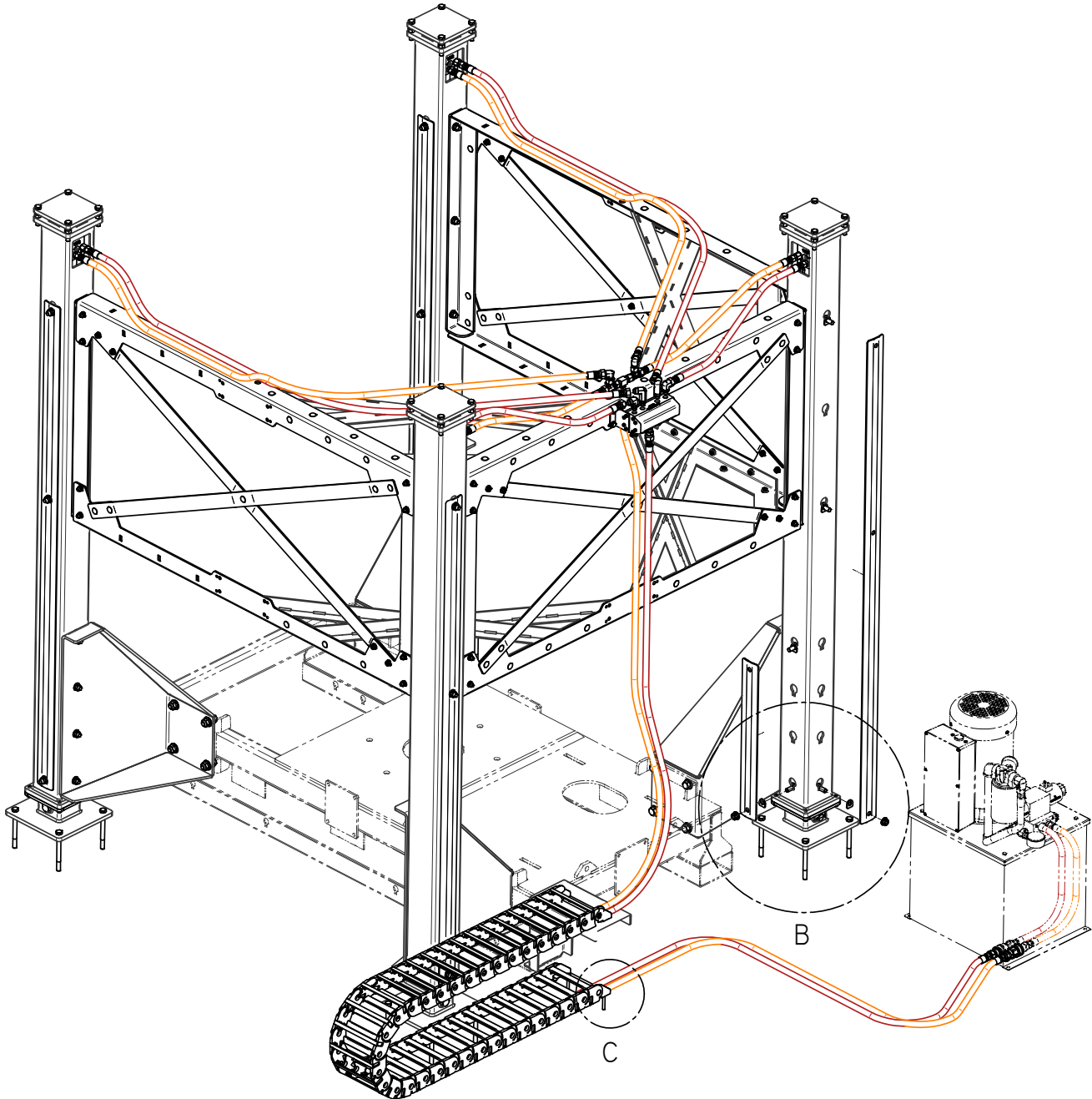

U-BATCH™ TREATER
HYDRAULIC LIFT ASSEMBLY (05-05-0145)

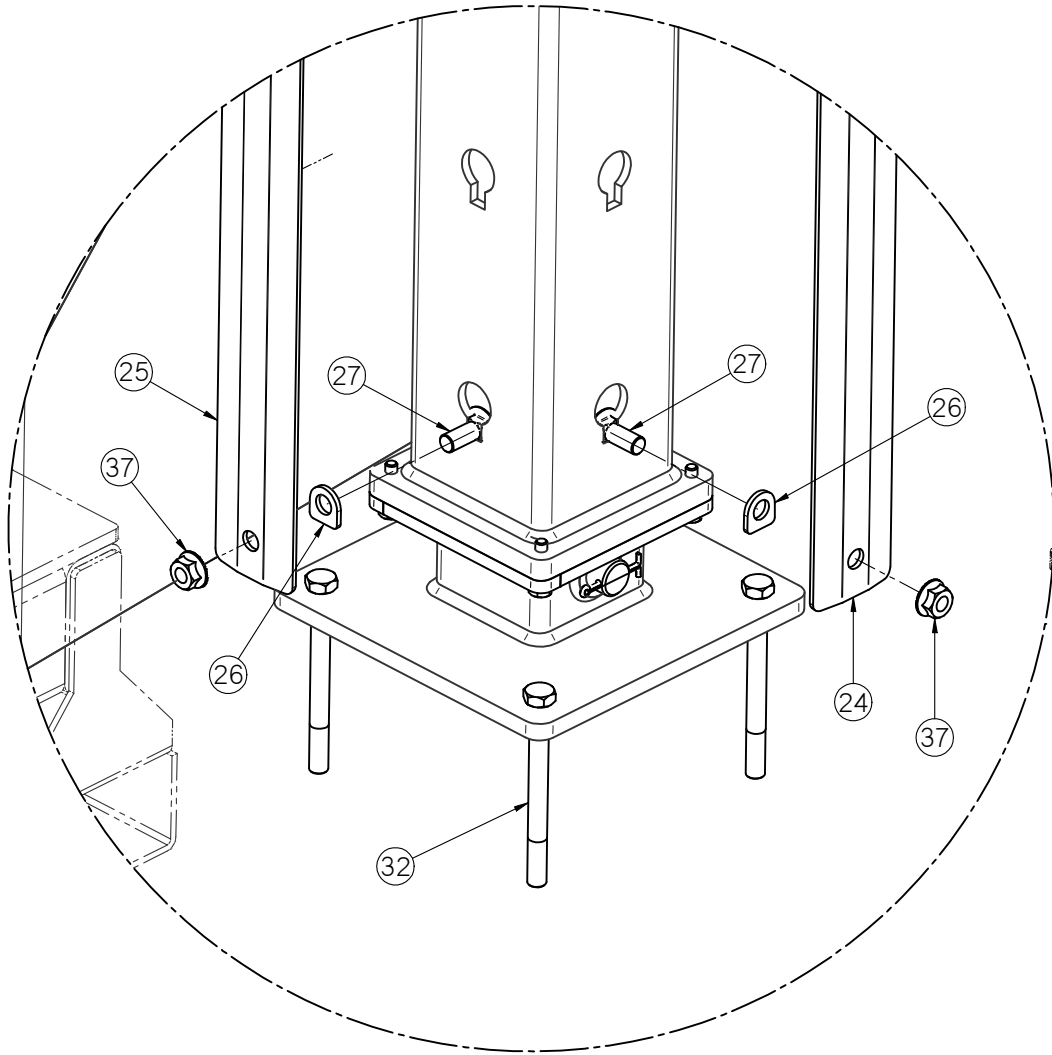

DETAIL B

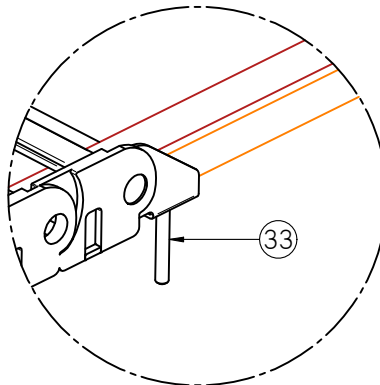

DETAIL C

HYDRAULIC LIFT ASSEMBLY (05-05-0145)

Item #	Part #	Description	Qty
1	02-05-0067	FTTG HYD QCK .500 NPT ISO 5675	1
2	02-05-0069	FTTG HYD STGHT 8MJ-8MOR	1
3	02-05-0124	FTTG HYD STGHT 6MJ-6MOR	8
4	02-05-0129	FTTG HYD STGHT 4MOR-6FOR	8
5	02-05-0133	FTTG HYD QCK .5 FM BODY X .500 FNPT	1
6	02-05-0137	FTTG HYD STGHT 6FOR-6MP	4
7	02-05-0138	FTTG HYD STGHT 8FOR-8MP	1
8	02-06-0059	FTTG HYD 90 DEG 8MJ-8FJX	2
9	02-06-0065	FTTG HYD 90 DEG 8MJ-6MOR	2
10	02-06-0099	FTTG HYD 90 DEG 8MJ-6MOR XX-LONG	2
11	02-09-0029	FTTG TEE HYD 8MJ-8MJ-8MJ BLKHD	1
12	02-09-0031	FTTG HYD TEE RUN 8MJ-8FJX-8MJ	2
13	03-07-0154	CBL TRACK DYNATECT KL3-14-4-86.625	1
14	03-17-0130	FD RTRY 4 SECT 1.7 TO 4.5 GPM_SECT	1
15	05-03-1642	WDMT BRACE CORNER BT	4
16	05-05-0138	ASSY LEG BT HYD 66.0IN STROKE	4
17	05-05-0143	WDMT MNT LEG BT HYD	2
18	05-05-0144	WDMT MNT LEG BT HYD 2	2
19	05-05-0158	WDMT MNT UPPER CBL TRK HYD LEGS	1
20	05-10-4439	STIFFENER LEGS BT HYD	6
21	05-10-4455	BRKT ANGLE FORMED PLT CS	6
22	05-10-4460	PLT GST STRAP	6
23	05-10-4533	PLT CLMP 4IN HOLE CTR	1
24	05-10-4534	CVR SAFETY LONG LEG HOLES	6
25	05-10-4536	CVR SAFETY SHORT LEG HOLES	2
26	05-10-4537	SPCR SAFETY CVR	22
27	06-01-0062	BOLT CRG .500-13 X 1.25 ZP GR5	56
28	06-01-0115	BOLT CRG .375-16 X 1.00 ZP GR5	24
29	06-01-0124	BOLT FLG .375-16 X .750 ZP GR5	4
30	06-01-0129	BOLT CRG .313-18 X .50 ZP GR5	2
31	06-01-0153	BOLT CRG .375-16X.750 ZP SHORT NECK	83
32	06-01-0179	BOLT,.500-13 CONC ANCHOR ZP 5.5 LONG	16
33	06-01-0180	BOLT,.3125 X 2.5 CONC ANCHOR ZP	2
34	06-01-0189	BOLT FLG .375-16 X 1.250 ZP GR5	2
35	06-01-0292	BOLT FLG .625-11 X 1.500 GR5 ZP	16

HYDRAULIC LIFT ASSEMBLY (05-05-0145)

Item #	Part #	Description	Qty
36	06-03-0014	NUT LOCK FLG .375-16 ZP GR5	113
37	06-03-0015	NUT LOCK FLG .500-13 ZP GR5	56
38	06-03-0019	NUT LOCK FLG .3125-18 ZP GR5	2
39	06-03-0023	NUT LOCK -8 JIC BLKHD	1
40	06-03-0029	NUT WHIZ LOCK FLG .625-11 GR5	16
41	13-05-0536	HHA .375ID 086.6IN -08FJX -06FJX	4
42	13-05-0537	HHA .375ID 032.0IN -08FJX -06FJX	4
43	13-05-0538	HHA .375ID 192.0IN -08FJX -08MP	2

DUST PICKUP HOOD ASSEMBLY (13-04-0229)

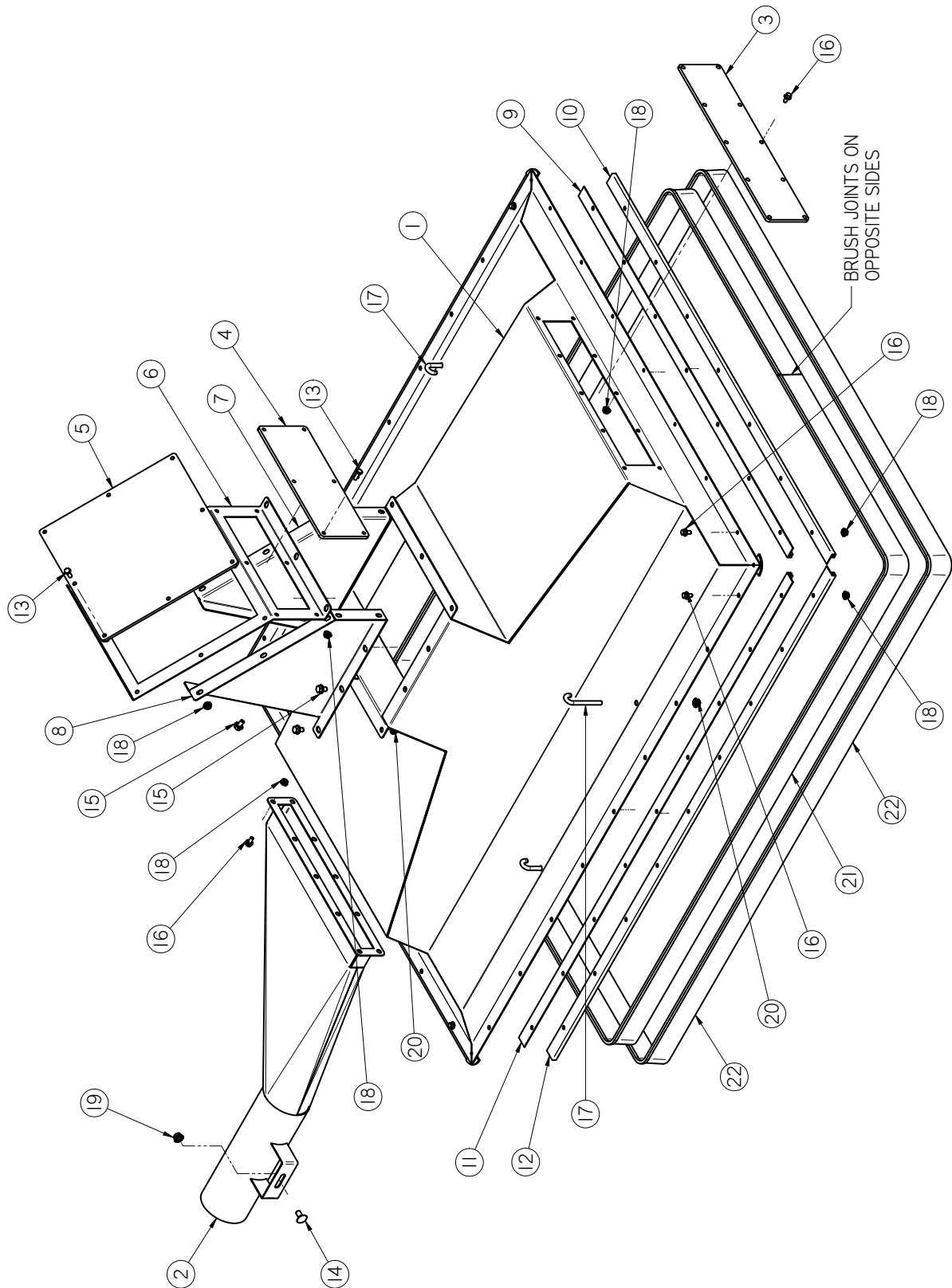

DUST PICKUP HOOD ASSEMBLY (13-04-0229)

Item #	Part #	Description	Qty
1	05-07-0862	WDMT HOOD DUST BT	1
2	05-07-0863	WDMT AIR PICKUP 4.0 OD BT	1
3	05-10-4431	CVR CLEAR VP FRNT DUST HOOD	1
4	05-10-4432	CVR CLEAR VP FRNT CHUTE	1
5	05-10-4433	CVR CLEAR VP TOP CHUTE	1
6	05-10-4434	FR TOP FRNT DUST HOOD DSCHG CHUTE	1
7	05-10-4435	FR SIDE 1 DUST HOOD DSCHG CHUTE	1
8	05-10-4436	FR SIDE 2 DUST HOOD DSCHG CHUTE	1
9	05-11-0476	HLDR BRSH SHORT INSIDE BT	2
10	05-11-0477	HLDR BRSH SHORT OUTSIDE BT	2
11	05-11-0478	HLDR BRSH LONG INSIDE BT	2
12	05-11-0479	HLDR BRSH LONG OUTSIDE BT	2
13	06-01-0006	BOLT .250-20 X .750 ZP GR5	14
14	06-01-0153	BOLT CRG .375-16X.750 ZP SHORT NECK	1
15	06-01-0261	BOLT FLG .3125-18 X .500 ZP GR5	10
16	06-01-0299	BOLT FLG .250-20 X .500 ZP GR5	52
17	06-01-0303	BOLT J .3125-18 X 3	4
18	06-03-0013	NUT,LOCK, FLG .250-20 ZP SERRATED	66
19	06-03-0014	NUT LOCK FLG .375-16 ZP GR5	1
20	06-03-0019	NUT LOCK FLG .3125-18 ZP GR5	9
21	06-10-0038	SEAL BRSH 1.99IN EXP	1
22	06-10-0038	SEAL BRSH 1.99IN EXP	1

U-BATCH™ TREATER
PNEUMATIC CONTROL ASSEMBLY (13-05-0517)

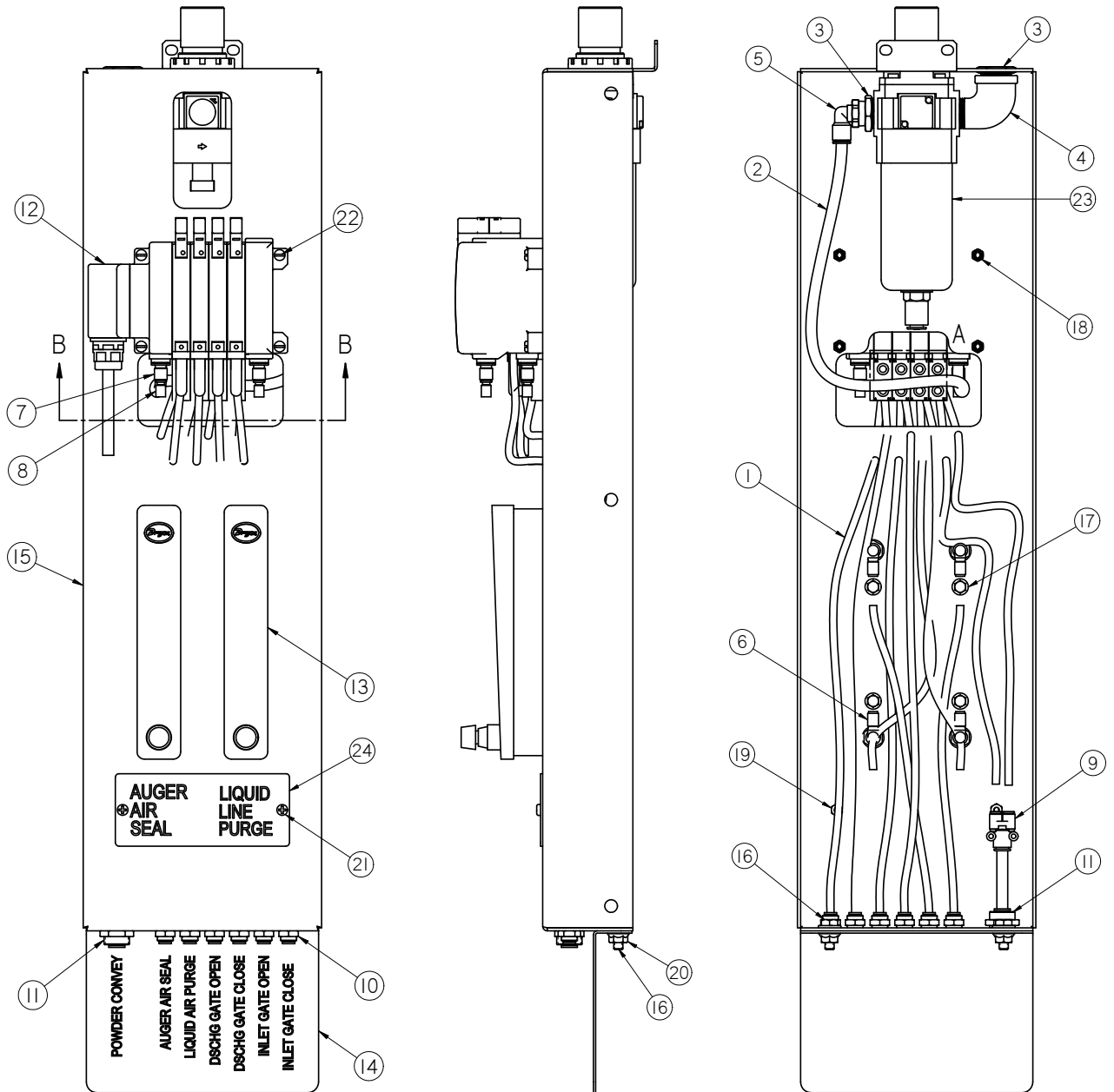

U-BATCH™ TREATER

PNEUMATIC CONTROL ASSEMBLY (13-05-0517)

Item #	Part #	Description	Qty
1	02-03-0051	TBG .250 OD NYL BLK - FEET	13.5
2	02-03-0052	TBG .375 OD NYL BLK - FEET	1.5
3	02-04-0013	FTTG BUSH .750NPT X .500NPT GALV	2
4	02-06-0068	FTTG 90 DEG STRT .75NPT PPE BLK	1
5	02-16-0008	FTTG PUSH 90 DEG .375OD X .500 NPT	1
6	02-16-0044	FTTG PUSH 90 DEG .250OD X .250 NPT	4
7	02-16-0053	FTTG PUSH RDCG .375 ML X .250 FM	2
8	02-16-0054	FTTG PUSH .25 BLANKING PLUG	2
9	02-16-0057	FTTG PUSH BRANCH .375 X .250 X .250	1
10	02-16-0059	FTTG PUSH BLKHD UNION .250 TUBE	6
11	02-16-0060	FTTG PUSH BLKHD UNION .375 TUBE	1
12	03-17-0120	VLV SOL MNFD AIR 24V BT68*	1
13	03-18-0031	FLMT VISUAL ADJ .8-8 SCFM	2
14	05-10-4437	LBL BT68 AIR CONNECTION	1
15	05-10-4466	PLT MNT AIR CONTROL VALVES	1
16	06-01-0124	BOLT FLG .375-16 X .750 ZP GR5	2
17	06-01-0299	BOLT FLG .250-20 X .500 ZP GR5	4
18	06-02-0043	NUT,LOCK, #10-24 ZP NYLON INSERT	4
19	06-02-0046	NUT, 10-24 UNC ZP	2
20	06-03-0014	NUT LOCK FLG .375-16 ZP GR5	2
21	06-06-0029	SCRW MACH 10-24 X .375 PHLP PHD ZP	2
22	06-06-0038	SRCW, PAN HD, 10-24 X 1.00 ZP	4
23	07-03-0022	REGL FLTR .750 W_GAUGE	1
24	104FB1	LBL BT FLOW CONTROLS	1

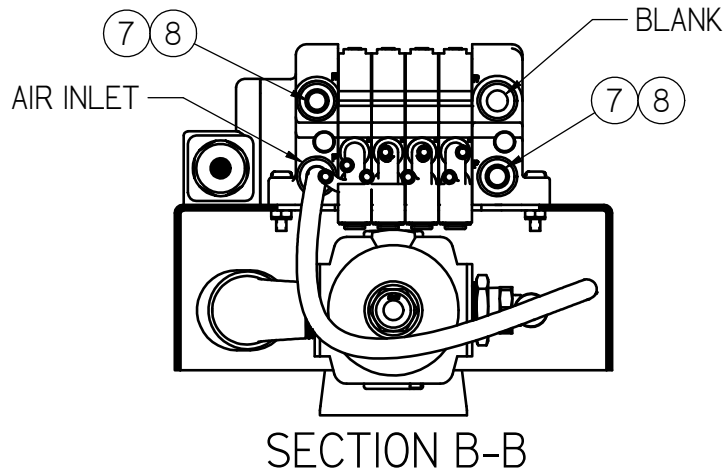

U-BATCH™ TREATER
CONTROL PACKAGE ASSEMBLY (13-12-0145)

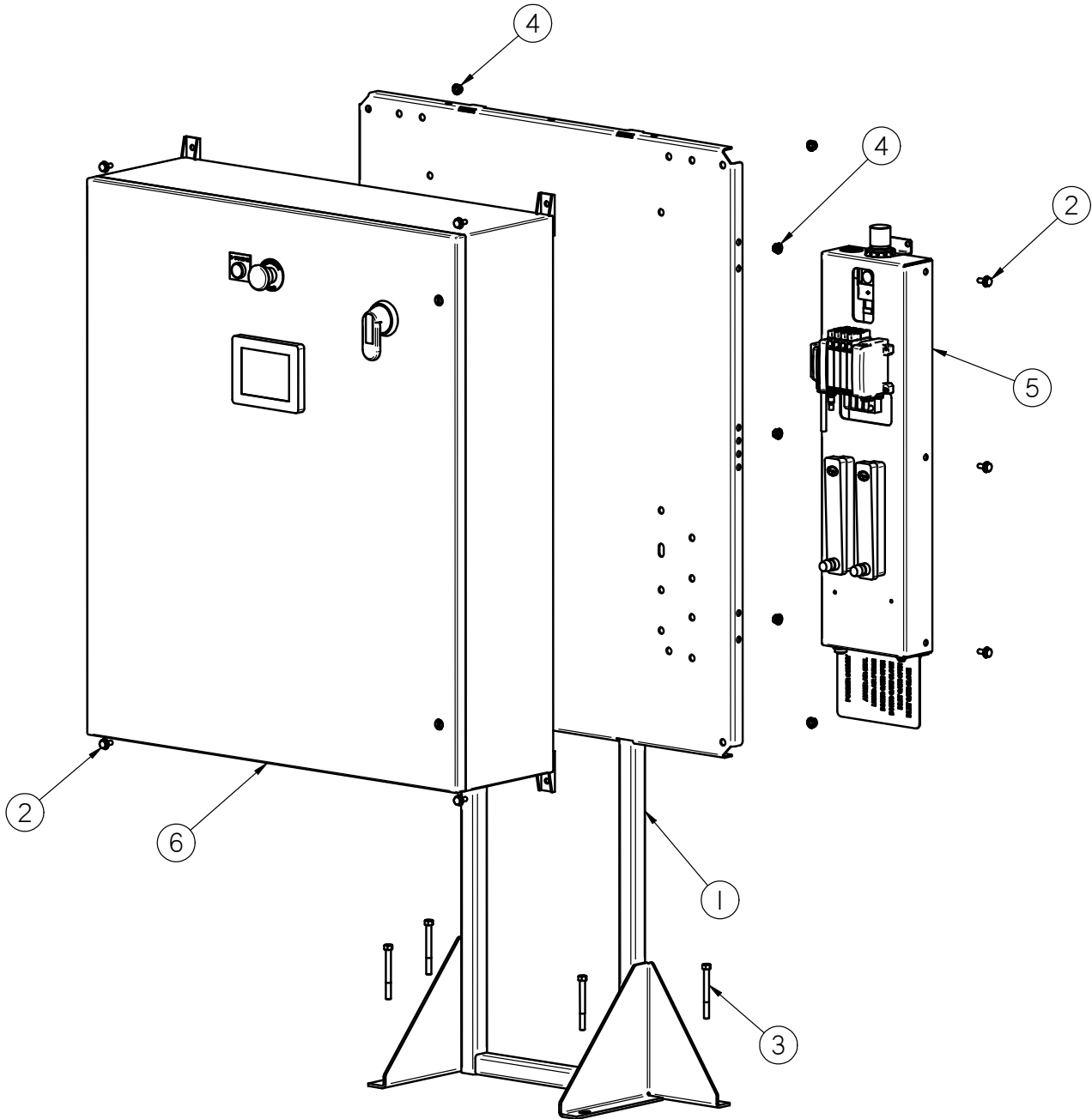

U-BATCH™ TREATER

CONTROL PACKAGE ASSEMBLY (13-12-0145)

Item #	Part #	Description	Qty
1	05-03-1342	WDMT MAIN CNTL PNL FR 36X42 ENCL	1
2	06-01-0124	BOLT FLG .375-16 X .750 ZP GR5	7
3	06-01-0220	BOLT 3/8-16 CONC ANCHOR ZP 3.75	4
4	06-03-0014	NUT LOCK FLG .375-16 ZP GR5	7
5	13-05-0517	ASSY AIR CNTL STTN BT	1
6	SEE TABLE 1	U-BATCH CONTROL PANEL	1

TABLE 1

Part #	Description
03-12-0516	PNL CNTL MNL BATCH TREATER 230V 1PH

U-BATCH™ TREATER
U-BATCH™ RIGID LEG TREATING SYSTEM

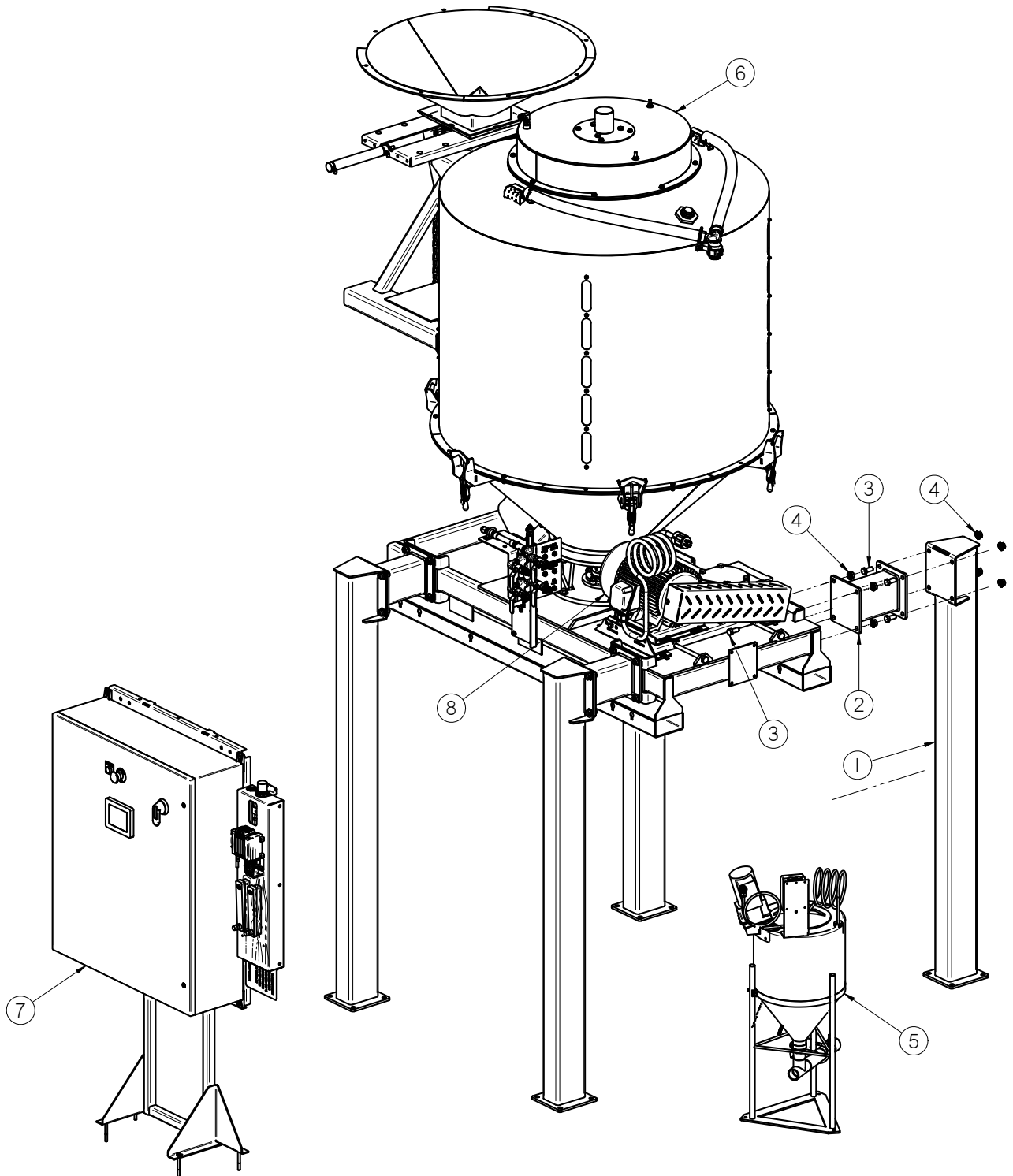

U-BATCH™ TREATER
U-BATCH™ RIGID LEG TREATING SYSTEM

Item #	Part #	Description	Qty
1	05-05-0122	WDMT LEG VERT VC PRO BOX	4
2	05-05-0123	WDMT LEG HORZ VC 10IN	4
3	06-01-0031	BOLT,.625-11 G5 ZP 1.50	32
4	06-03-0029	NUT WHIZ LOCK FLG .625-11 GR5	32
5	13-05-0500	POWDER DELIVERY HOPPER 10 GAL	1
6	13-11-0035	ASSY BASE BT68 BATCH COATER CS	1
7	SEE TABLE 1	CNTL PKG U-BATCH TREATER	1
8	SEE TABLE 2	10 HP AUGER DRIVE MOTOR KIT	1

TABLE 1	
Part #	Description
13-12-0145	U-BATCH CONTROL PACKAGE ASSEMBLY 230V 1PH

TABLE 2	
Part #	Description
03-20-0172	KIT MTR BT 10HP AUGER DRV

U-BATCH™ TREATER

U-BATCH™ WITH HYDRAULIC LIFT TREATING SYSTEM

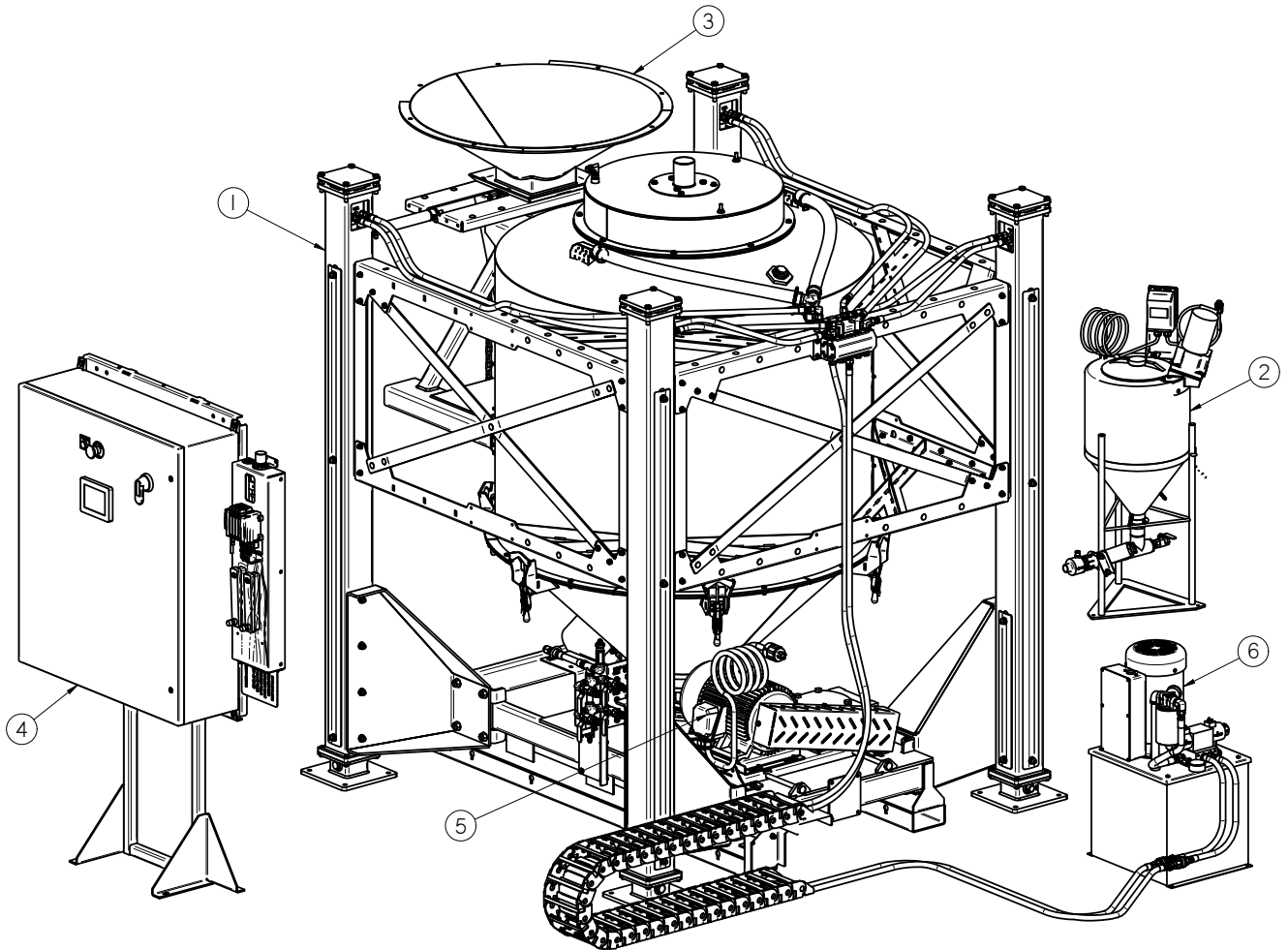

U-BATCH™ TREATER

U-BATCH™ WITH HYDRAULIC LIFT TREATING SYSTEM

Item #	Part #	Description	Qty
1	05-05-0145	ASSY LEGS BT HYD 66.0IN STROKE	1
2	13-05-0500	POWDER DELIVERY HOPPER 10 GAL	1
3	13-11-0035	ASSY BASE BT68 BATCH COATER CS	1
4	SEE TABLE 1	CNTL PKG U-BATCH TREATER	1
5	SEE TABLE 2	10 HP AUGER DRIVE MOTOR KIT	1
6	SEE TABLE 3	5HP HYDRAULIC PWR PKG 6.7GPM	1

TABLE 1

Part #	Description
13-12-0145	U-BATCH CONTROL PACKAGE ASSEMBLY 230V 1PH

TABLE 2

Part #	Description
03-20-0172	KIT MTR BT 10HP AUGER DRV

TABLE 3

Part #	Description
13-08-0681	5HP HYDRAULIC PWR PKG 230V 1PH 6.7 GPM

U-BATCH™ TREATER

NOTES:

USC LIMITED WARRANTY**SECTION
K**

USC, LLC, (Manufacturer) warrants its seed treating equipment as follows:

1. **Limited Warranty:** Manufacturer warrants that the Products sold hereunder will be free from defects in material and workmanship for a period of 18 months from date of shipment. If the Products do not conform to this Limited Warranty during the warranty period, Buyer shall notify Manufacturer in writing of the claimed defects and demonstrate to Manufacturer satisfaction that said defects are covered by this Limited Warranty. If the defects are properly reported to Manufacturer within the warranty period, and the defects are of such type and nature as to be covered by this warranty, Manufacturer shall, at its expense, furnish replacement Products or, at Manufacturer's option, replacement parts for the defective products. Shipping and installation of the replacement Products or replacement parts shall be at the Buyer's expense.
2. **Other Limits:** THE FOREGOING IS IN LIEU OF ALL OTHER WARRANTIES, EXPRESSED OR IMPLIED, INCLUDING BUT NOT LIMITED TO THE IMPLIED WARRANTIES OF MERCHANTABILITY AND FITNESS FOR A PARTICULAR PURPOSE. Manufacturer does not warrant against damages or defects arising from improper installation (where installation is by persons other than Manufacturer), against defects in products or components not manufactured by Manufacturer, or against damages resulting from such non-Manufacturer made products or components. Manufacturer passes on to the Buyer the warranty it received (if any) from the maker of such non-Manufacturer made products or components. This warranty also does not apply to Products upon which repairs and / or modifications have been effected or attempted by persons other than pursuant to written authorization by Manufacturer. This includes any welding on equipment which could damage electrical components. Manufacturer does not warrant against casualties or damages resulting from misuse and / or abuse of Products, improper storage or handling, acts of nature, effects of weather, including effects of weather due to outside storage, accidents, or damages incurred during transportation by common carrier.
3. **Exclusive Obligation:** THIS WARRANTY IS EXCLUSIVE. The sole and exclusive obligation of Manufacturer shall be to repair or replace the defective Products in the manner and for the period provided above. Manufacturer shall not have any other obligation with respect to the Products or any part thereof, whether based on contract, tort, strict liability or otherwise. Under no circumstances, whether based on this Limited Warranty or otherwise, shall Manufacturer be liable for lost profits, lost revenue, lost sales (whether direct or indirect damages), incidental, special, punitive, indirect or consequential damages.
4. **Other Statements:** Manufacturer's employees or representatives' oral or other written statements do not constitute warranties, shall not be relied upon by Buyer, and are not a part of the contract for sale or this limited warranty.
5. **Return Policy:** Approval is required prior to returning goods to Manufacturer. A restocking fee will apply.
6. **Entire Obligation:** This Limited Warranty states the entire obligation of Manufacturer with respect to the Products. If any part of this Limited Warranty is determined to be void or illegal, the remainder shall remain in full force and effect.

US / Canada Non-Exclusive 2016



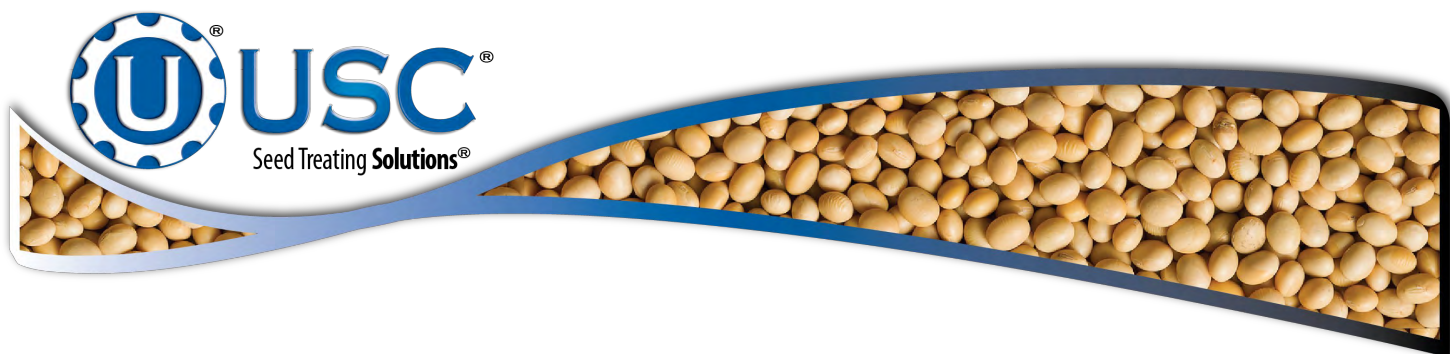

USC, LLC

2320 124th road

Sabetha, KS 66534

PHONE: (785) 431-7900

FAX: (785) 431-7950

EMAIL: sales-team@uscllc.com

WEB: www.uscllc.com

