

FIELD LOADER CONVEYOR



OPERATOR'S MANUAL

Document: TD-09-06-1070

Revision: C

Effective Date: 01-2021



2320 124th Road Sabetha, KS 66534

Phone:(785) 431-7900

www.uscllc.com

INTRODUCTION

Thank you for choosing USC, LLC for your equipment needs. We appreciate your business and will work diligently to ensure that you are satisfied with your choice.

OVERVIEW

The purpose of this manual is to provide you with the basic information needed to operate and maintain the Field Loader Conveyor. It does not hold USC, LLC liable for any accidents or injuries that may occur.

The technical information provided in this document is based on extensive testing under controlled conditions at the USC research and development facility. This information is given without guarantee as the conditions of operation and storage of the equipment are beyond our control.

RECEIVING YOUR EQUIPMENT

As soon as the equipment is received, it should be carefully inspected to make certain that it has sustained no damage during shipment and that all items listed on the packing list are accounted for. If there is any damage or shortages, the purchaser must immediately notify USC, LLC. Ownership passes to purchaser when the unit leaves the USC LLC premises. The purchaser is responsible for unloading and mounting all components of the equipment.

Document the serial number of the machine for future reference. The serialization label is located on the inlet end the conveyor near the transition.

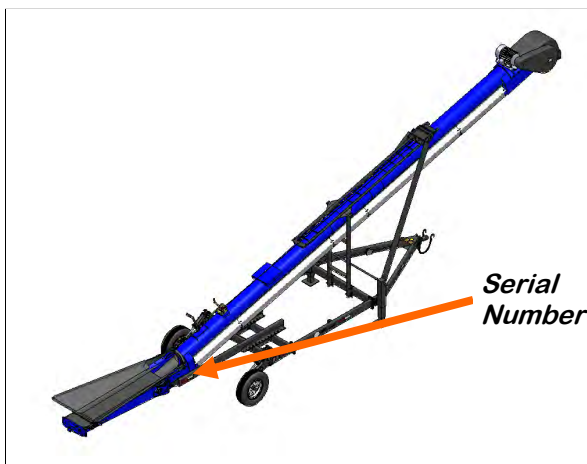

SERIAL NUMBER: _____

TABLE OF CONTENTS

<u>Section</u>	<u>Contents</u>	<u>Page #</u>
Section A	Safety Instructions	4
	Safety Labels.....	14
Section B	Installation	22
	Undercarriage Assembly	23
	Undercarriage & Conveyor Assembly	24
	Trailer & conveyor assembly	25
Section C	Mechanical Operation	28
	Pre-Operation Check List	29
	Operating Hints	29
	Emergency Stopping	30
	Restarting	30
	Machine Break-In	30
	Conveyor with Undercarriage Overview.....	32
	Conveyor with Undercarriage Operation	33
	Conveyor with Trailer Overview	34
	Conveyor with Trailer Operation	35
	Remote Control	36
	Learning the Remote	37
	Gas Powered Power Pack.....	38
Self-Mover	40	
Section D	Troubleshooting	43
Section E	Maintenance.....	44
	Conveyor Servicing Intervals	45
	Belt Tensioning & Alignment - Inlet End.....	46
	Belt Alignment - S-Drive	47
	Belt Alignment - Head End	48
	Belt Replacement	49
	Drive Belt Tensioning & Alignment	50
Section F	Storage.....	52
Section G	Limited Warranty	54

SECTION
A**SAFETY INSTRUCTIONS**

Every year accidents in the work place maim, kill and injure people. Although it may be impossible to prevent all accidents, with the right combination of training, operating practices, safety devices and operator vigilance, the number of accidents can be significantly reduced. The purpose of this section is to educate equipment users about hazards, unsafe practices and recommended hazard avoidance techniques.

SAFETY WORDS AND SYMBOLS

It is very important that operators and maintenance personnel understand the words and symbols that are used to communicate safety information. Safety words, their meaning and format, have been standardized for U.S. manufacturers and published by the American National Standards Institute (ANSI). The European Community (E.C.) has adopted a different format based on the International Standards Organization (I.S.O.) and applicable machinery directives. Both formats are presented below. Graphic symbols are not standardized but most manufacturers will use some variation of the ones seen in this manual.



Indicates an imminently hazardous situation which, if not avoided, **will** result in death or serious injury.



Indicates a potentially hazardous situation which, if not avoided, **could** result in death or serious injury.



Indicates a potentially hazardous situation which, if not avoided, **may** result in minor or moderate injury and/or property damage.



Provides additional information that the operator needs to be aware of to avoid a potentially hazardous situation.



Mandatory Lockout Power Symbol. Disconnect, lockout and tagout electrical and other energy sources before inspecting, cleaning or performing maintenance on this panel.



International Safety Alert Symbol. The exclamation point (!) surrounded by a yellow triangle indicates that an injury hazard exists. However, it does not indicate the seriousness of potential injury. The exclamation point (!) is also used with the DANGER, WARNING and CAUTION symbols so the potential injury is indicated.



Electrocution Hazard Symbol. This symbol indicates that an electrocution hazard exists. Serious injury or death could result from contacting high voltage.



International Electrocution Hazard. This symbol indicates that an electrocution hazard exists. Serious injury or death could result from contacting high voltage.



Mandatory Read Manual Action Symbol. (I.S.O. format) This symbol instructs personnel to read the Operators Manual before servicing or operating the equipment.



Mandatory Read Manual Action Symbol. This symbol instructs personnel to read the Operators Manual before servicing or operating the equipment.

NOTICE

Notice is used to notify people of important installation, operation or maintenance information which is not hazard related.

LOCKOUT / TAGOUT PROCEDURES

Lockout/Tagout is the placement of a lock/tag on an energy isolating device in accordance with an established procedure. When taking equipment out of service to perform maintenance or repair work, always follow the lockout/tagout procedures as outlined in OSHA Standard 1910.147. This standard “requires employers to establish a program and utilize procedures for affixing appropriate lockout devices or tagout devices to energy isolating devices and to otherwise disable machines or equipment to prevent unexpected energizing, start-up, or release of stored energy in order to prevent injury to employees.”

CONTROLLED STOP

This is the stopping of machine motion by reducing the electrical command signal to 0 (zero) once the stop signal has been recognized.

HAZARD REVIEW

Electrocution Hazard



Electrocution accidents are most likely to occur during maintenance of the electrical system or when working on or near exposed high voltage wiring. This hazard does not exist when the electrical power has been disconnected, properly locked, and tagged out.



Automatic Start Hazard

This equipment may be controlled by an automated system and may start without warning. Failure to properly disconnect, lockout, and tagout all energy sources of remotely controlled equipment creates a very hazardous situation and could cause injury or even death. PLEASE STAY CLEAR AND BE ALERT.



FIELD LOADER CONVEYOR

YOU are responsible for the **SAFE** operation and maintenance of your USC, LLC equipment . **YOU** must ensure that you and anyone else who is going to operate, maintain or work around the equipment be familiar with the operating and maintenance procedures and related **SAFETY** information contained in this manual. This manual will take you step-by-step through your working day and alert you to good safety practices that should be adhered to while operating the equipment

Remember, **YOU** are the key to safety. Good safety practices not only protect you, but also the people around you. Make these practices a working part of your safety program. Be certain that **EVERYONE** operating this equipment is familiar with the recommended operating and maintenance procedures and follows all the safety precautions. Most accidents can be prevented. Do not risk injury or death by ignoring good safety practices.

- Equipment owners must give operating instructions to operators or employees before allowing them to operate the machine, and at least annually thereafter per OSHA (Occupational Safety and Health Administration) regulation 1928.57.
- The most important safety device on this equipment is a **SAFE** operator. It is the operator's responsibility to read and understand **ALL** Safety and Operating instructions in the manual and to follow them. All accidents can be avoided.
- A person who has not read and understood all operating and safety instructions is not qualified to operate the machine. An untrained operator exposes himself and bystanders to possible serious injury or death.
- Do not modify the equipment in any way. Unauthorized modification may impair the function and/or safety and could affect the life of the equipment.
- Think SAFETY! Work SAFELY!

GENERAL SAFETY

1. Read and understand the operator's manual and all safety labels before operating, maintaining, adjusting or unplugging the equipment .
2. Only trained persons shall operate the equipment . An untrained operator is not qualified to operate the machine.
3. Have a first-aid kit available for use should the need arise, and know how to use it.



FIELD LOADER CONVEYOR

4. Provide a fire extinguisher for use in case of an accident. Store in a highly visible place.
5. Do not allow children, spectators or bystanders within hazard area of machine.

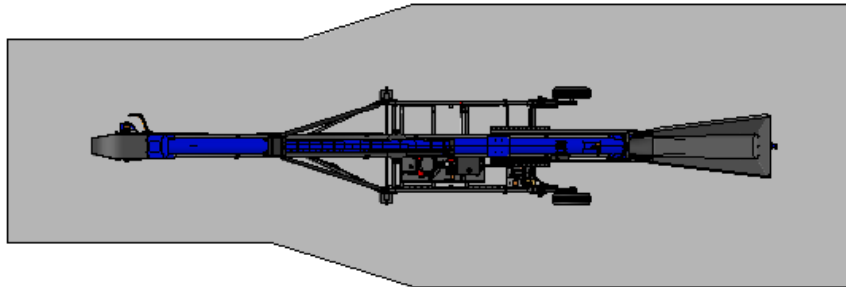

The grey area above represents the hazard area about the field loader . Keep unauthorized people out of this area. If someone enters this area — immediately shut the conveyor down.

6. Wear appropriate protective gear. This includes but is not limited to:

- A hard hat
- Protective shoes with slip resistant soles
- Protective goggles
- Heavy gloves
- Hearing protection
- Respirator or filter mask



7. Place all controls in neutral or off, stop motor, and wait for all moving parts to stop. Then disable power source before servicing, adjusting, repairing, or unplugging.
8. Review safety related items annually with all personnel who will be operating or maintaining the equipment.



FIELD LOADER CONVEYOR

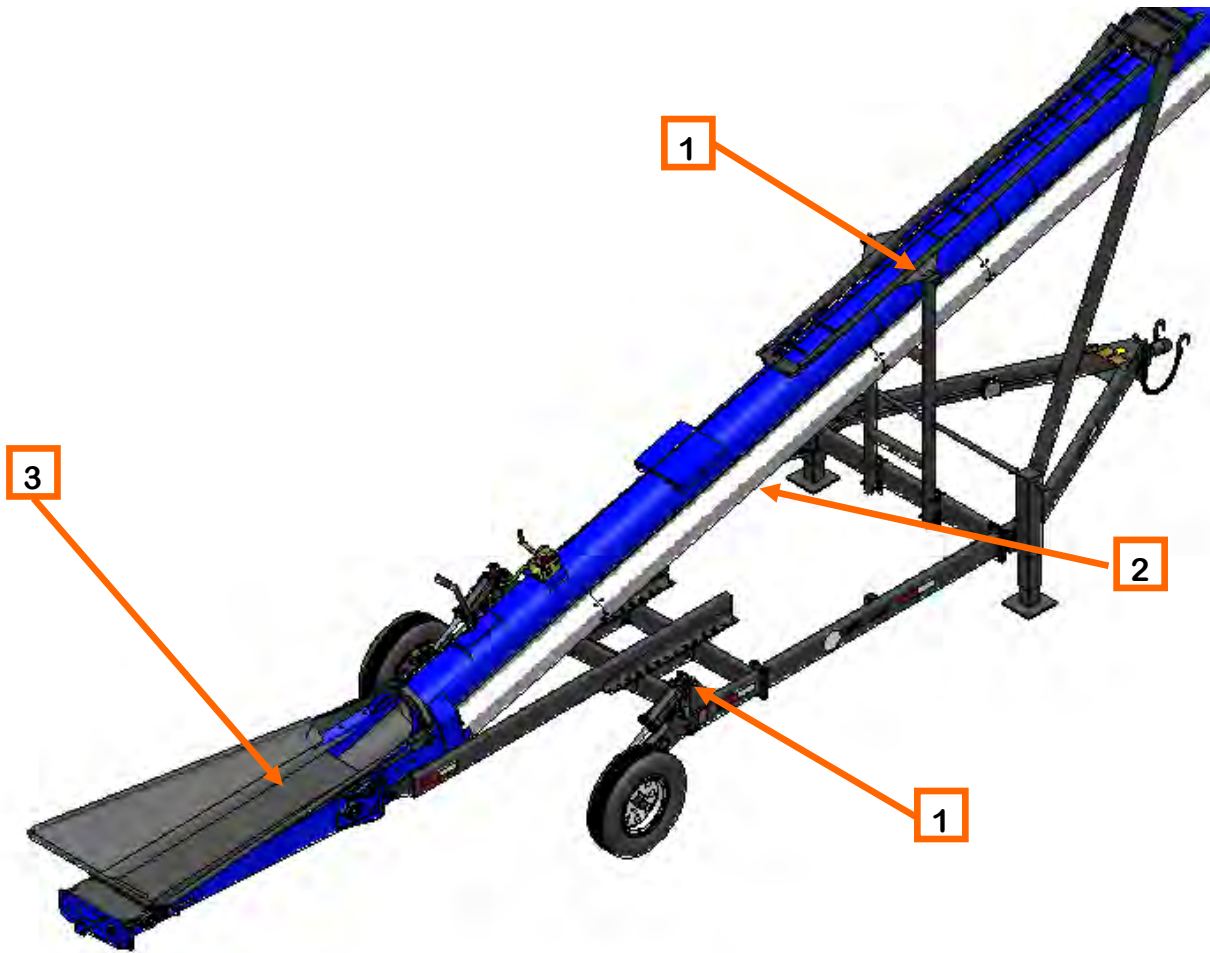

1. Pinch points. Keep body parts and clothing out of these areas while the equipment is moving.
2. Exposed belt. Do not reach under the conveyor while it is running. Stop the conveyor prior to coming within 2 feet of the bottom of the conveyor. Do not walk under the conveyor while running.
3. Entrapment Hazard. The moving belt can drag clothing, or body parts into the tube.

OPERATING SAFETY:

1. Read and understand the operator's manual and all safety labels before using.
2. Disconnect and disable electrical supply completely and wait for all moving parts to stop before servicing, adjusting, repairing or unplugging.
3. Clear the area of bystanders, especially children, before starting.
4. Be familiar with the machine hazard area. If anyone enters hazard area, shut down machine immediately. Clear the area before restarting.
5. Keep hands, feet, hair and clothing away from all moving and/or rotating parts.
6. Stay away from overhead obstructions and power lines during operation and transporting. Electrocutation can occur without direct contact.
7. Do not operate machine when any guards are removed.
8. Inspect welds and repair if needed.

TRANSPORT SAFETY

1. Read and understand ALL the information in the operator's manuals regarding procedures and SAFETY when moving or transporting the conveyor.
2. Check with local authorities regarding conveyor transport on public roads. Obey all applicable laws and regulations.
3. Always travel at a safe speed. Use caution when making corners or meeting traffic.
4. Make sure the SMV (Slow Moving Vehicle) emblem and all the lights and reflectors that are required by the local highway and transport authorities are in place, are clean and can be seen clearly by all overtaking and oncoming traffic.
5. Do not allow riders on the conveyor or the towing vehicle when transporting.
6. Attach undercarriage style conveyor to towing vehicle with a pin and retainer.
7. Attach trailer style conveyor to towing vehicle with a 2 5/16 inch ball.
8. Lower conveyor to its lowest position for transporting.
9. Keep to the right and yield the right-of-way to allow faster traffic to pass. Drive on the road shoulder, if permitted by law.
10. Do not exceed 25 m.p.h. (40 km/h). Reduce speed on rough roads and surfaces.
11. Stay away from overhead obstructions and power lines when transporting. Electrocutation can occur without direct contact.
12. Always use hazard warning flashers on tractor when transporting unless prohibited by law.

PLACEMENT SAFETY

1. Move only with the appropriate equipment
2. Stay away from overhead power lines when moving the conveyor. Electrocutation can occur without direct contact.
3. Be familiar with machine hazard area. If anyone enters hazard areas, shut down machine immediately. Clear the area before restarting.
4. Operate the conveyor on level ground free of debris. Anchor the conveyor to prevent tipping or upending.

TIRE SAFETY

1. Failure to follow proper procedures when mounting a tire on a wheel or rim can produce an explosion which may result in serious injury or death.
2. Do not attempt to mount a tire unless you have the proper equipment and experience to do the job.
3. Have a qualified tire dealer or repair service perform required tire maintenance.
4. When replacing worn tires, make sure they meet the original tire specifications. Never undersize.



Before placement of the conveyor, be sure that ground is reasonably level. The conveyor may topple or work improperly if the ground is too uneven, damaging the equipment and/or causing personal injury.



When releasing the conveyor from the towing vehicle, test the intake end for downward weight. Do not raise the intake end above drawbar height. When the intake end is elevated too high with machine in raise position, the balance of weight quickly transfers to the discharge end.

MAINTENANCE SAFETY

1. Review the operator's manual and all safety items before working with, maintaining or operating the equipment.
2. Place all controls in neutral or off, stop motors, disable power source, and wait for all moving parts to stop before servicing, adjusting, repairing or unplugging.
3. Follow good shop practices:
 - Keep service area clean and dry.
 - Be sure electrical outlets and tools are properly grounded.
 - Use adequate light for the job at hand.
4. Keep hands, feet, hair and clothing away from all moving and/or rotating parts.
5. Clear the area of bystanders, especially children, when carrying out any maintenance and repairs or making any adjustments.
6. Before resuming work, install and secure all guards when maintenance work is completed.
7. Keep safety signs clean. Replace any sign that is damaged or not clearly visible.



SAFETY LABELS

1. Keep safety labels clean and legible at all times.
2. Replace safety labels that are missing or have become illegible.
3. Replaced parts that displayed a safety label should also display the current label.
4. Replacement safety labels are available. Contact your authorized dealer.

How to Install Safety Labels:

- Be sure that the installation area is clean and dry.
- Be sure temperature is above 50°F (10°C).
- Decide on the exact position before you remove the backing paper.
- Remove the smallest portion of the split backing paper.
- Align the sign over the specified area and carefully press the small portion with the exposed sticky backing in place.
- Slowly peel back the remaining paper and carefully smooth the remaining portion of the sign in place.
- Small air pockets can be pierced with a pin and smoothed out using the piece of sign backing paper.



Located on the USC equipment you will find safety labels. Always be sure to read and follow all directions on the labels.



Guards provided with USC equipment are to remain in place during operation.

FIELD LOADER CONVEYOR

Think **SAFETY!** Work **SAFELY!**

REMEMBER—If safety labels have been damaged, removed, become illegible, or parts replaced without safety labels, new labels must be applied. New safety labels are available from your authorized dealer.



PART # 09-02-0001



PART # 09-02-0002

FIELD LOADER CONVEYOR



PART # 09-02-0009



PART # 09-02-0011

Located
Under
guard



PART # 09-02-0012

FIELD LOADER CONVEYOR



PART # 09-02-0031



PART # 09-02-0015

FIELD LOADER CONVEYOR

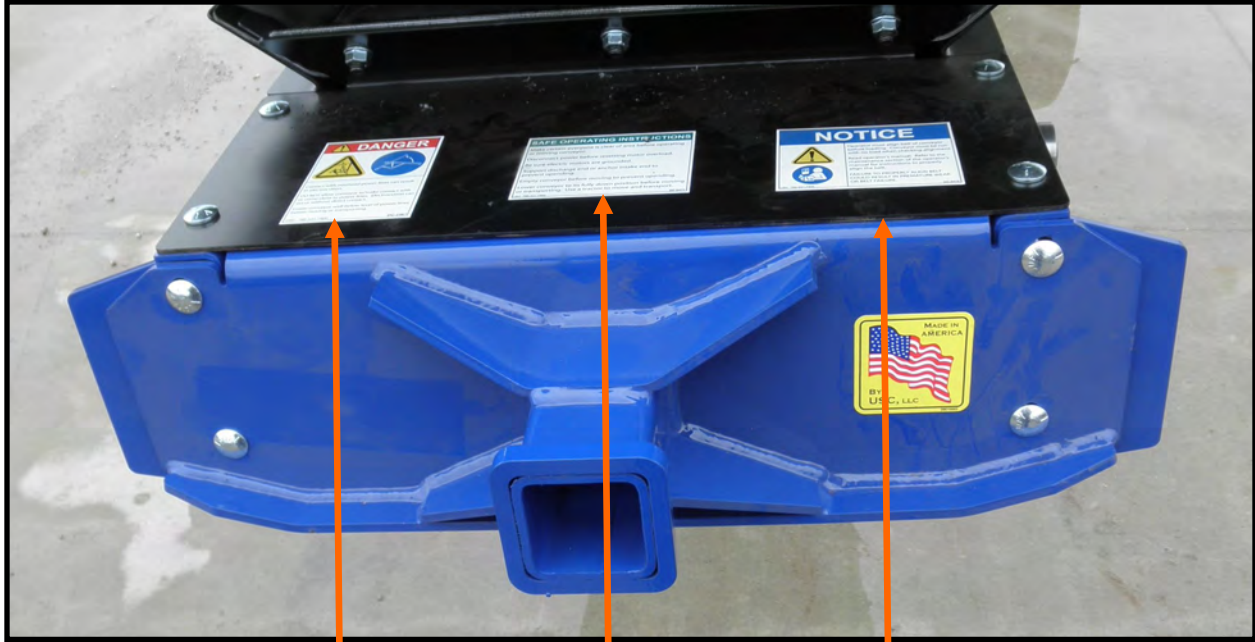

PART # 09-02-0008

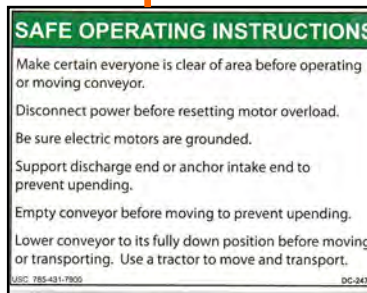

PART # 09-02-0032



PART # 09-02-0031



PART # 09-02-0027

FIELD LOADER CONVEYOR



SAFE OPERATING INSTRUCTIONS

Make certain everyone is clear of area before operating or moving conveyor.

Disconnect power before resetting motor overload.

Be sure electric motors are grounded.

Support discharge end or anchor intake end to prevent upending.

Empty conveyor before moving to prevent upending.

Lower conveyor to its fully down position before moving or transporting. Use a tractor to move and transport.

USC 785-431-7900 DC-2467

PART # 09-02-0032

DANGER

Contact with overhead power lines can result in electrocution.

DO NOT allow conveyor to make contact with or come close to power lines. Electrocution can occur without direct contact.

Lower conveyor well below level of power lines before moving or transporting.

USC 785-431-7900 DC-2467

PART # 09-02-0028

FIELD LOADER CONVEYOR



PART # 09-02-0027

FIELD LOADER CONVEYOR



PART # 09-02-0033



PART # 09-02-0034

SECTION
B**INSTALLATION**

Be sure to use safe working habits when assembling your equipment. Assembly of the Field Loader conveyor requires physical strength and strain, make sure you are in healthy physical condition and have adequate assistance. USC is not liable for any injuries that occur while assembling or using this equipment.



HIGH VOLTAGE ~ Always disconnect the power source before working on or near the control panel or lead wires.



HIGH VOLTAGE ~ Use insulated tools when making adjustments while the controls are under power.

CONTROLS

Electric Drive: if using an electric motor, have a licensed electrician provide power to the machine per the National Electrical Code ANSI/NFPA 70 and local codes. For customer safety and ease of use, a motor disconnect switch may be mounted on the conveyor depending on options ordered. 3-phase models will require end-user supplied motor thermal overload protection”

UNDERCARRIAGE ASSEMBLY

The following instructions should be used to assemble your USC conveyor undercarriage. Hand tighten all fastener until conveyor/undercarriage are mated. If the conveyor was purchased with factory assembly, skip this section.

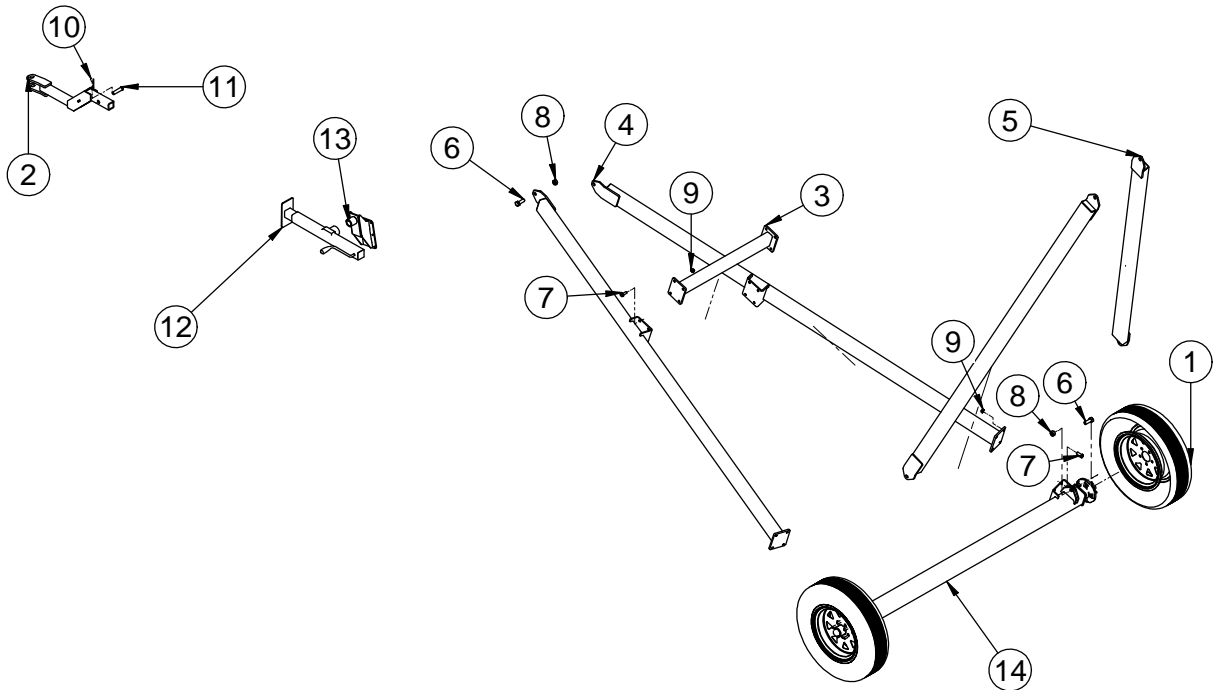

1. Place axle (14) on ground or raised supports and remove the lug nuts.
2. Install tires (1) on the axle with the lug nuts and torque to 90 to 120 ft/lbs.
3. Remove the supports from under axle if used.
4. Install 2 lower arm weldments (4) to the axle using 8 each flange bolt 1/2-13 x 1.5 (7) and flange lock nut 1/2-13 (9).
5. Install 1 cross brace (3) using 8 each flange bolts 1/2-13 x 1.5 (7) and flange lock nut 1/2-13 (9).
6. Install 2 upper arms with 2 each bolt 3/4-10 x 2 grade 5 (6) and nylock nut 3/4-10 (8)
7. The remaining parts will be used to attach the undercarriage to the conveyor.
8. Leave nuts and bolts loose. They will all be tightened after the undercarriage and conveyor are mated.

UNDERCARRIAGE & CONVEYOR ASSEMBLY

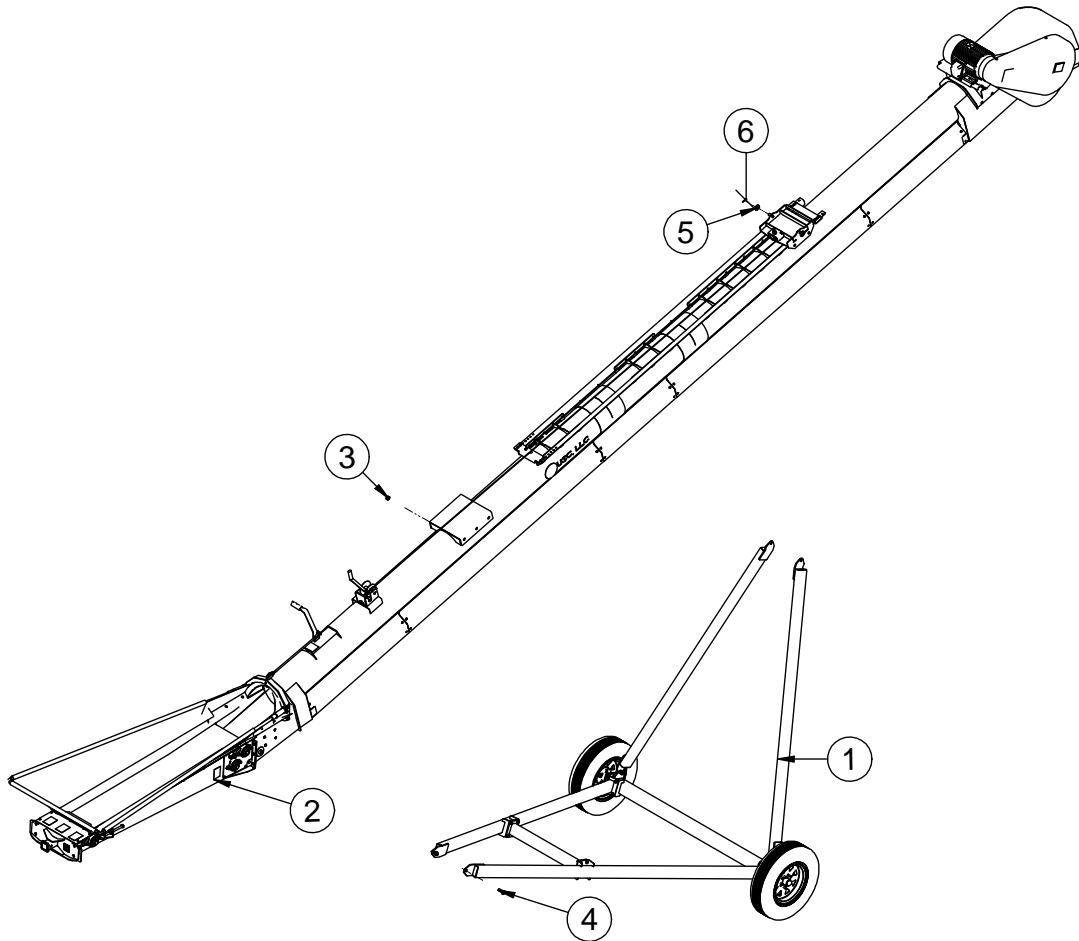

1. Remove washer (5) and cotter pin (6) from both sides of the head end slide.
2. Raise the conveyor head using a suitably safe lifting device (2) and maneuver the carriage under the conveyor.
3. Lower the conveyor and secure the head end arms over the pins that the washers (5) and cotter pin (6) were just removed.
4. Reinstall the washers (5) and cotter pins (6) on both sides of the conveyor.
5. Adjust position of conveyor (2) to align the rear arms with the mount and secure with bolt 3/4-10X 2 (4) and secure with 3/4-10 lock nut (3).
6. Release the head of the conveyor from the lifting device. It is now supported by the undercarriage.
7. Cycle the conveyor up to check for binding and smooth operation.



Do not allow any part of your body below the conveyor while it is raised.

FIELD LOADER CONVEYOR
TRAILER & CONVEYOR ASSEMBLY

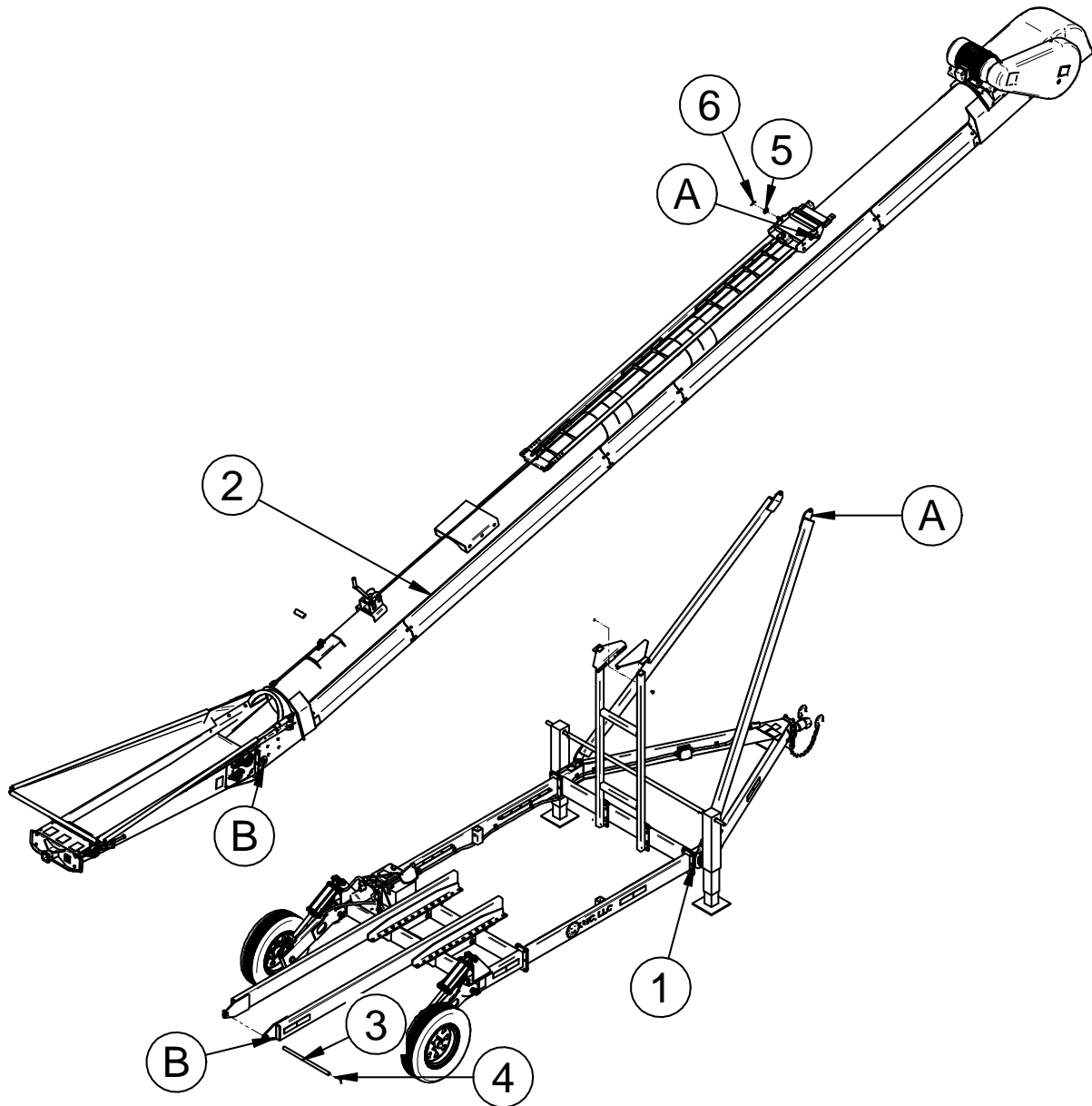

TRAILER & CONVEYOR ASSEMBLY

1. Remove the pins (6) and washers (5) from the point A on the conveyor
2. Remove the pin (4) and shaft (3) from either the trailer or the conveyor at point B
3. Carefully lift the head of the conveyor with a suitably safe lifting device.



Do not allow any part of your body below the conveyor while it is raised.

4. Maneuver the trailer under the elevated conveyor so that the points B on prior page line up. Being careful not to have any part of your body below the conveyor.
5. Reinsert the shaft (3) and secure with pin (4)
6. Adjust height of head of conveyor until the points A line up and the arms may be slipped over the studs at point A on trailer.
7. Secure with the washer (5) and pins (6) on both sides of the conveyor.
8. Release the head of the conveyor from the lifting device. It is now totally supported by the trailer.
9. Manually raise and lower the conveyor to check for binding and smooth operation.
10. Check the slide stop so that it hits the stop the same time as the conveyor support.
11. If not adjust the stop so that both support the conveyor simultaneously. See next page.

FIELD LOADER CONVEYOR
TRAILER & CONVEYOR ASSEMBLY

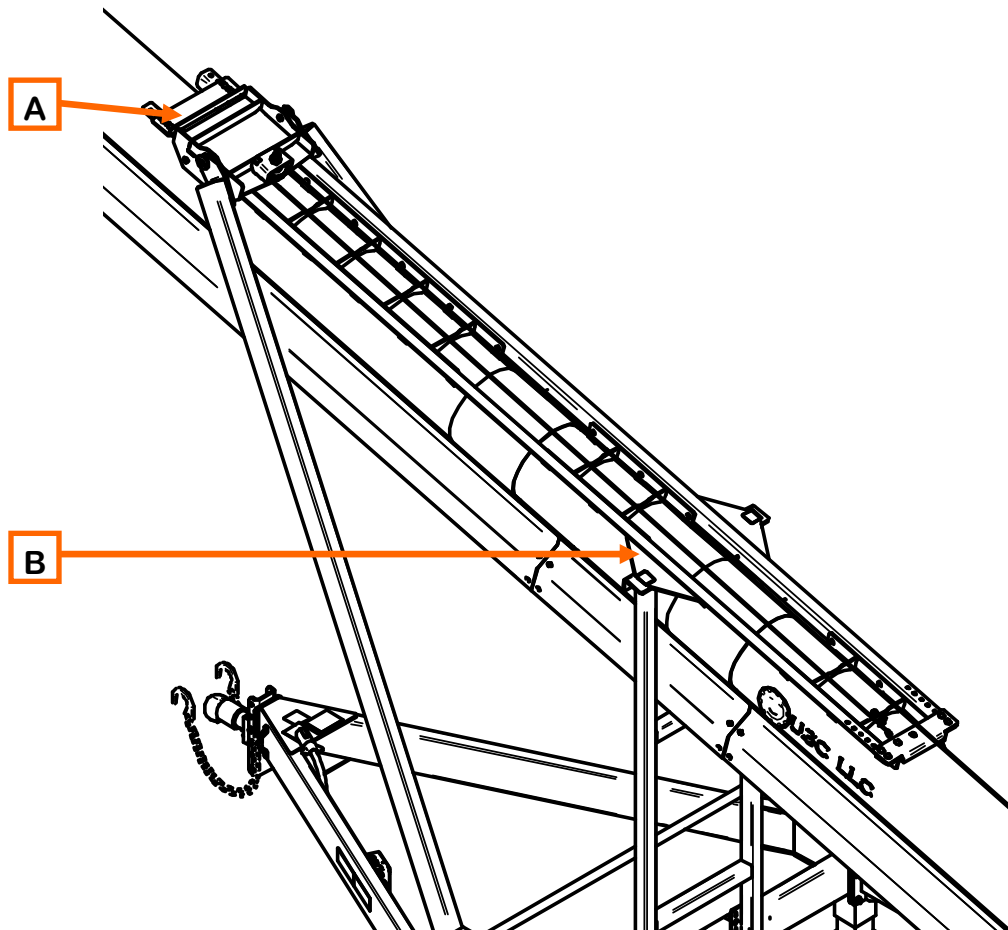

1. In the event that the slide stop (A) does not hit the stop at the same time as the conveyor support (B) or vice versa.
2. Raise the conveyor off both stops.
3. Adjust either the stop (A) or the support (B) as needed by removing the bolts and moving the part accordingly.
4. Re-bolt the part removed.
5. Re-test.
6. If it is still off, repeat steps 2 through 5.

SECTION
C**MECHANICAL OPERATION****OPERATING SAFETY**

1. Read and understand the Operator's Manual and all safety signs before using.
2. Electric motor drives: Disconnect and disable electrical supply completely and wait for all moving parts to stop before servicing, adjusting, repairing or unplugging.
3. Clear the area of bystanders, especially children, before starting.
4. Be familiar with machine hazard area. If anyone enters hazard areas, shut down machine immediately. Clear the area before restarting.
5. Keep hands, feet, hair and clothing away from all moving and/or rotating parts.
6. Do not allow riders on the Conveyor or transport vehicle when transporting.
7. Stay away from overhead obstructions and power lines during operation and transporting. Electro-cution can occur without direct contact.
8. Do not operate machine when any guards are removed.
9. Lower Conveyor to its lowest position before moving or transporting or when not in use.
10. Inspect lift cable before using Conveyor. Replace if frayed or damaged.
11. Make certain lift cable is properly seated in cable pulleys.
12. Be sure that conveyor is empty before raising or lowering.

Power may be provided by either an electric or hydraulic motor. Be familiar with the machine before starting.

It is the responsibility of the owner or operator to read this manual and to train all other operators before they start working with the machine. In addition to the design and configuration of equipment, hazard control and accident prevention are dependent upon the awareness, concern, and prudence of personnel involved in the operation, transport, maintenance and storage of equipment or in the use and maintenance of facilities.

NOTICE

Follow all safety instructions exactly. Safety is everyone's business. By following recommended procedures, a safe working environment is provided for the operator, bystanders and the area around the worksite. Untrained operators are not qualified to operate the machine.

Many features incorporated into this machine are the result of suggestions made by customers like you. Read this manual carefully to learn how to operate the machine safely and how to set it to provide maximum efficiency. By following the operating instructions in conjunction with a good maintenance program, your conveyor will provide many years of trouble free service.

PRE-OPERATION CHECKLIST

Efficient and safe operation of the Field Loader Conveyor requires that each operator reads and understands the operating procedures and all related safety precautions outlined in this section. A pre-operation checklist is provided for the operator. It is important for both the personal safety and maintaining the good mechanical condition of the Conveyor that this checklist is followed.

Before operating the Conveyor and each time thereafter, the following areas should be checked off:

1. Service the machine per the schedule outlined in Section D, Maintenance (see page 45).
2. Use only an electric motor of adequate power to operate the machine.
3. Check that all guards are installed, secured and functioning as intended. Do not operate with missing or damaged shields.
4. Check worksite. Clean up working area to prevent slipping or tripping.
5. Check that drive belt and conveying belt are not frayed or damaged and that they are properly adjusted and aligned.
6. Check that discharge chute is free of obstructions.

OPERATING HINTS

- Always listen for any unusual sounds or noises. If any are heard, stop the machine and determine the source. Correct the problem before resuming work.
- Never allow anyone into the workplace hazard area. If anyone enters, stop immediately.
- Do not run the machine for long periods of time with no material on the belt. It increases the wear. Try to run the conveyor only when moving material.
- Always check and make sure the belt is properly aligned. Neglecting your belt may lead to wear and possible breakage.
- Always disconnect power from the conveyor when its not being operated in case of power surges.
- If the conveyor is equipped with a hydraulic drive motor. Make sure the tractor hydraulic pressure is a minimum of 2400 PSI.

EMERGENCY STOPPING

Although it is recommended that the machine be emptied before stopping, in an emergency situation, stop or shutdown the power source immediately. Correct the emergency before resuming work.

RESTARTING

When the machine is shut down inadvertently or for an emergency, the belt may still be covered with material. It may be necessary to tighten the drive belt slightly to handle the heavier-than-normal starting loads.

MACHINE BREAK-IN

Although there are no operational restrictions on the conveyor when used for the first time, it is recommended that the following mechanical items be checked:

Before Starting

1. Read the Conveyor Operator's Manual.
2. During the conveyors first few minutes of operation, check conveyor belt alignment to ensure belt is tracking correctly when running empty and also during loaded conditions.
3. Check that all safety decals are installed and legible. Apply new decals if required.

After Operating for 1/2 Hour

1. Re-torque fasteners and hardware.
2. Check the drive belt tension and alignment. Tension or align as required.
3. Check the conveying belt tension and alignment. Tension or align as required.
4. Check that all guards are installed and working as intended.

After Operating for 5 Hours and 10 Hours

1. Re-torque all bolts, fasteners and hardware.
2. Check that all guards are installed, secured and functioning as intended. Do not operate with missing or damaged shields.
3. Check safety decals. Install new ones if required.

FIELD LOADER CONVEYOR

4. Check the drive belt, and conveying belt tension and alignment. Tension or align as required.
5. Then go to the normal servicing and maintenance schedule as defined in the Maintenance Section.

FIELD LOADER CONVEYOR
CONVEYOR WITH UNDERCARRIAGE OVERVIEW

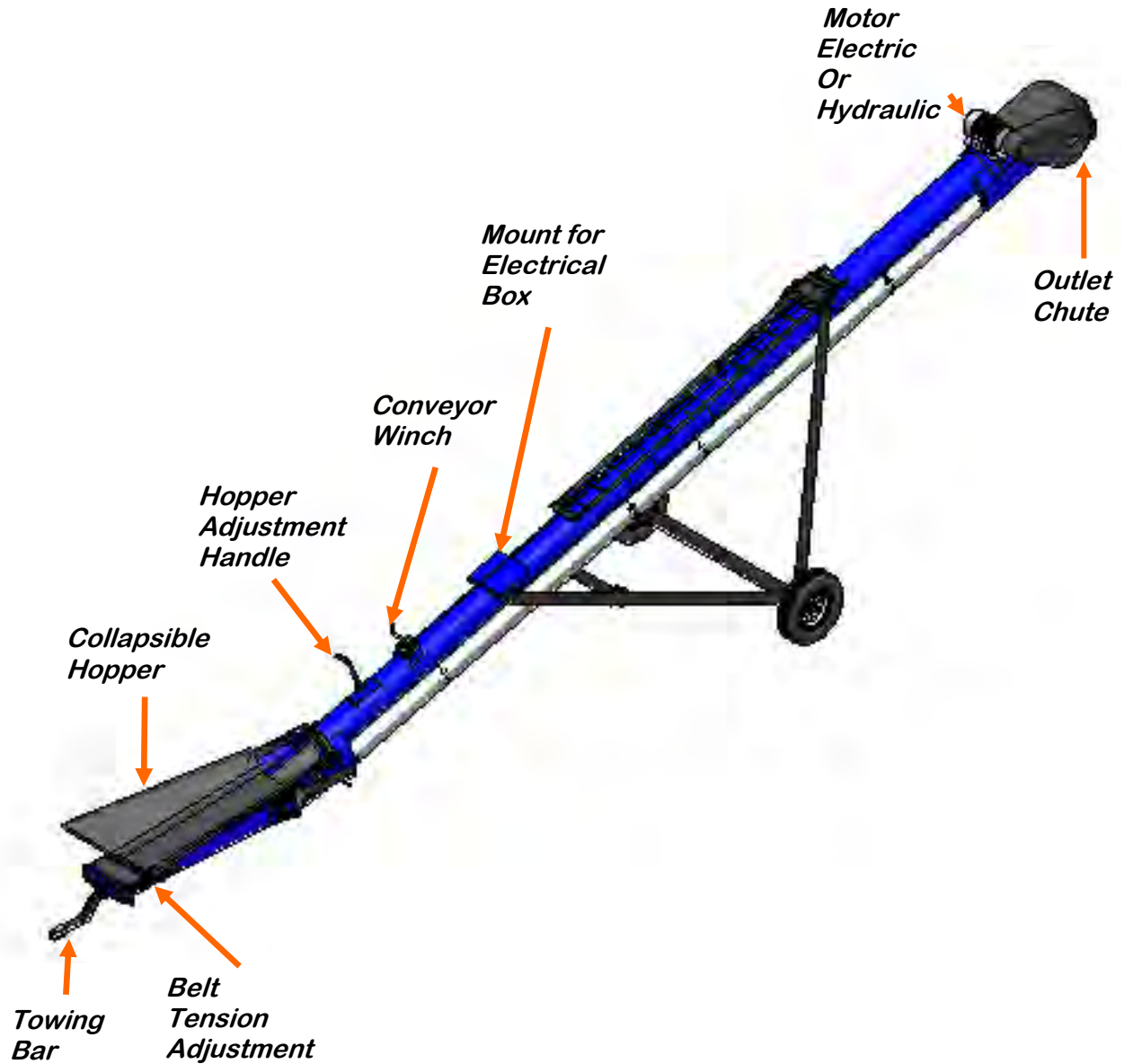

NOTE: The conveyor is not designed to operate above 25 degrees. Raising the conveyor above this angle will cause reduced thru put.

CONVEYOR WITH UNDERCARRIAGE OPERATION

1. With the hopper in the down position, maneuver the inlet hopper under the grain source (bin, field cart, truck, etc.).
2. Raise the hopper.
3. Adjust the height of the conveyor to clear the receiving vessel (bin, field cart, truck, etc.).
4. Connect the conveyor to power and turn on the power.
5. Open the grain source gate.
6. When finished, close the grain source gate.
7. Allow all the grain to exit the Field Loader conveyor and turn off the conveyor.
8. Lower the conveyor and inlet hopper after the receiving vessel has pulled away.
9. Move to next location and repeat.

FIELD LOADER CONVEYOR
CONVEYOR WITH TRAILER OVERVIEW

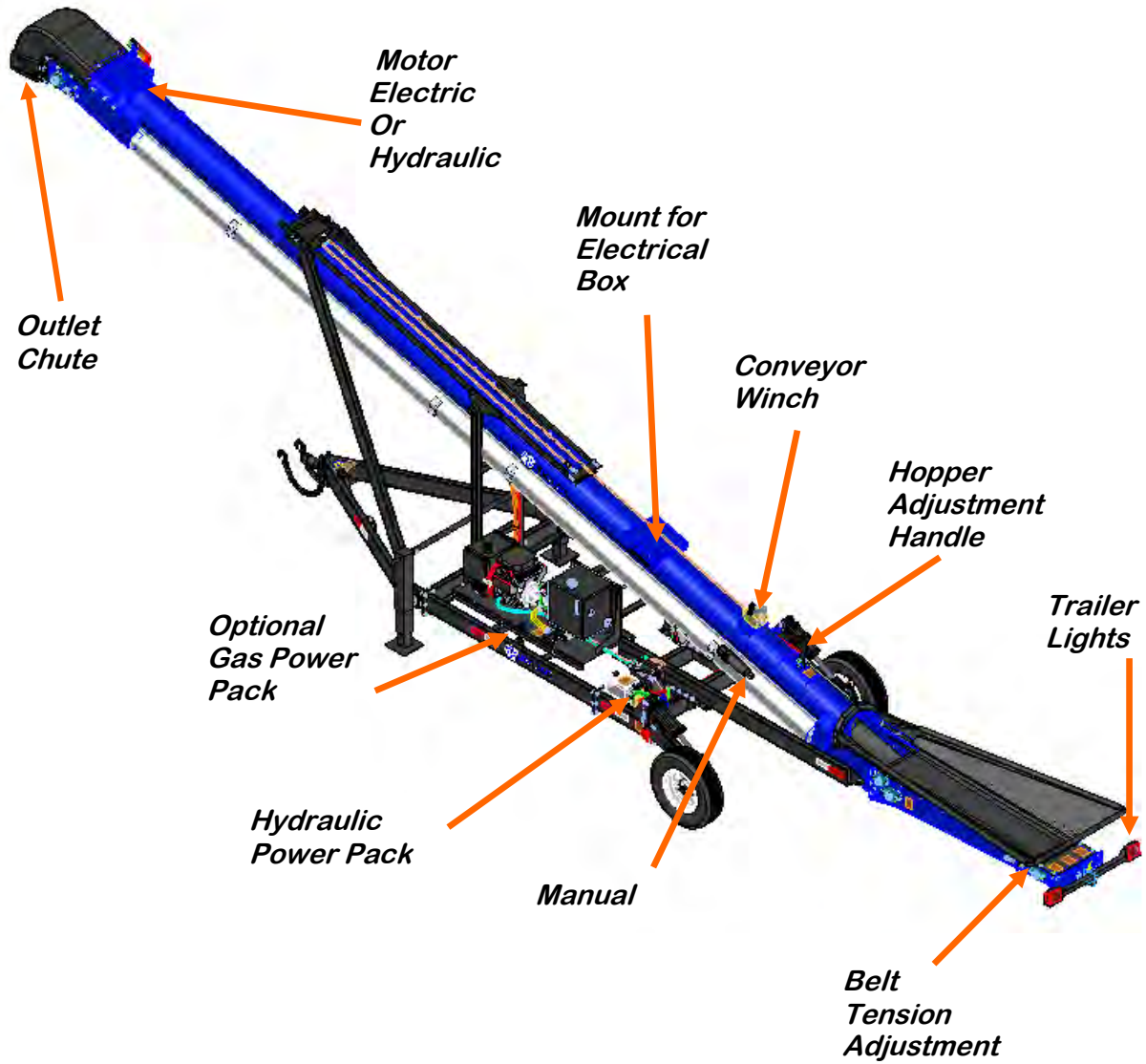

CONVEYOR WITH TRAILER OPERATION

1. Remove red pins (1 each side) from the axle pivots. Position A is the storage position for the pins. Position B is the locked position.
2. Remove the trailer lights from the inlet end of the conveyor.
3. Using either the hardwired or remote hydraulic control, lower the conveyor to the ground. (C) up, (D) down.
4. With the hopper in the down position, maneuver the inlet hopper under the grain source (bin, field cart, truck, etc.)
5. Disconnect from towing vehicle and move out of the way.
6. Raise the hopper.
7. Adjust the height of the conveyor to clear the receiving vessel (bin, field cart, truck, etc.).
8. Connect the conveyor to power and turn on the power.
9. Open the grain source gate.
10. When finished, close the grain source gate.
11. Allow all the grain to exit the Field Loader conveyor and turn off the conveyor.
12. Raise the trailer and lower inlet hopper after receiving vessel has pulled away.
13. Prior to transport, reinstall the two red pins and trailer lights.
14. Move to next location and repeat.

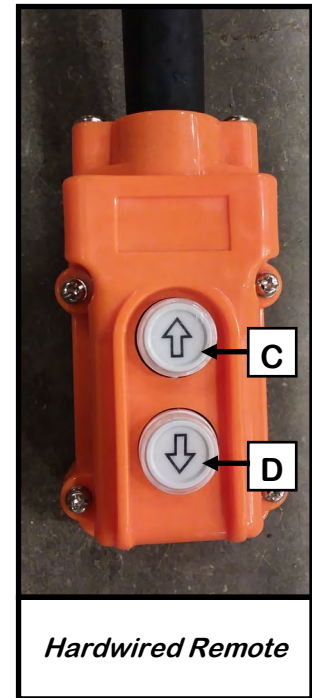
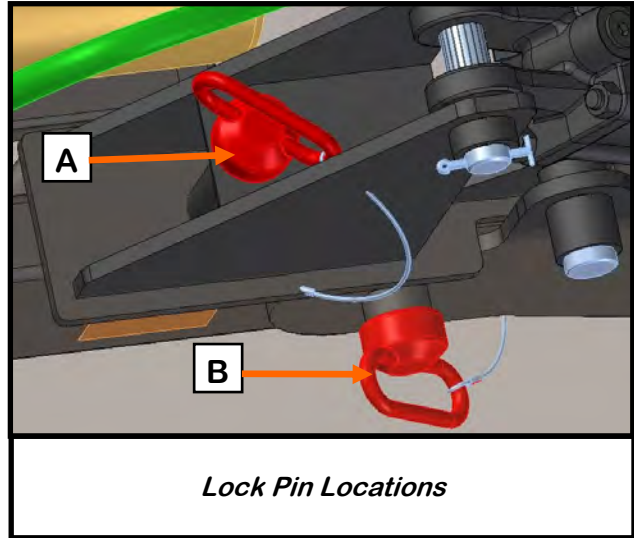

REMOTE HYDRAULIC KIT OPERATION

OPERATION

1. Depress the on/off button on the transmitter to activate (B). The blue light on the top should turn on. The transmitter has a safety time-out feature. When the unit was active and then not used for 1 minute it will automatically turn off. Just hit the on/off button to turn it back on!
2. On the transmitter depress and hold the UP Button (A) to raise the trailer.
3. Depress and hold the DOWN Button (C) to lower the trailer.
4. The switch mounted on the receiver module will function the same as the transmitter buttons.

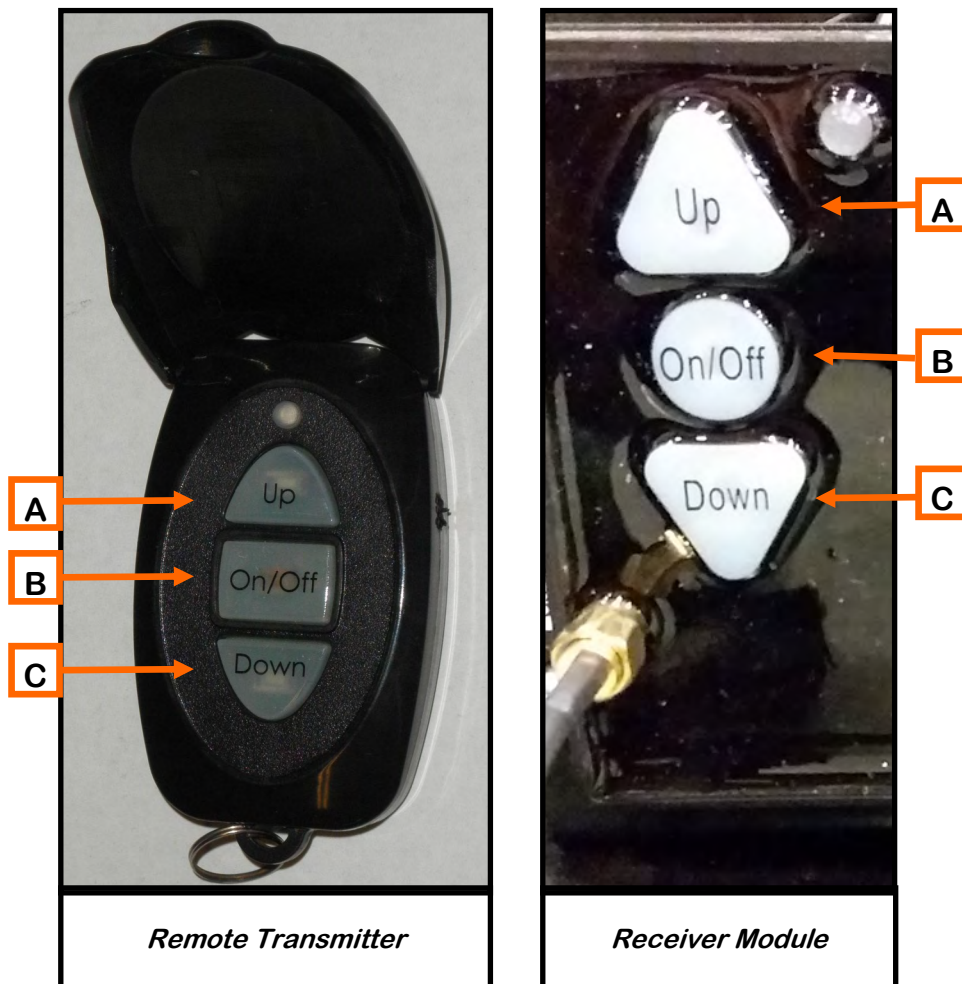

How to learn a transmitter

1. Enter the learn mode: Push and hold the on/off button on the Receiver Module (B) until the LED (A) starts to flash. Then release the button (B)
2. Push and hold the on/off button (C) on the transmitter until the LED (A) on the Receiver Module comes on constant.
3. Release the on/off button. The transmitter is now learned.
4. Option: learn another transmitter by repeating steps 1 through 3. Note: the Receiver Module exits the “learn mode” after each transmitter is learned. You can learn up to 8 transmitters.
5. To clear all transmitters out of the Receiver Module: Push and hold the on/off button (B) on the Receiver Module for 10 seconds.
6. Test the remote to insure that up moves trailer up, etc. If not reverse wires blue and gray.

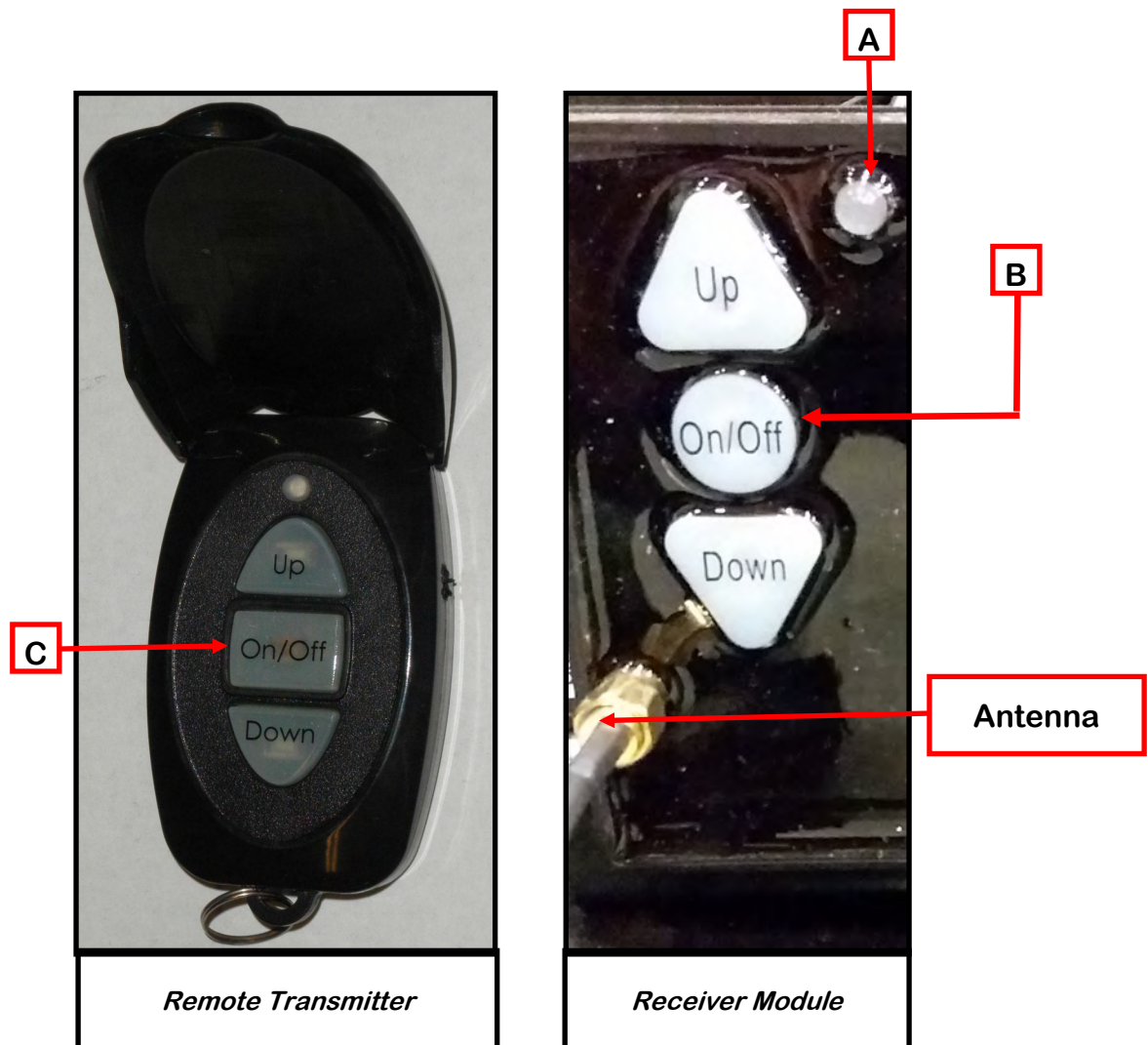

GAS POWERED HYDRAULIC POWER PACK

PRE-START-UP CHECKS

1. Check around and under the engine for signs of oil or gasoline leaks.
2. Remove any excessive dirt or debris, especially around the muffler.
3. Look for signs of damage.
4. Check that all shields and covers are in place and all nuts, bolts, and screws are tightened.
5. Check the fuel level. Starting with a full tank will help to eliminate or reduce interruptions for refueling.
6. Check engine oil level.
7. Check that the air filter is clean.

STARTING THE ENGINE

DO NOT START ENGINE IN CONFINED SPACE (BARN, ETC).



The exhaust contains poisonous carbon monoxide gas that can build up to dangerous levels in enclosed areas. Breathing carbon monoxide can cause unconsciousness or death.

1. Make sure that the conveyor is in the OFF position.
2. The fuel tank is equipped with a shut off valve. Be sure that it is in the open position.

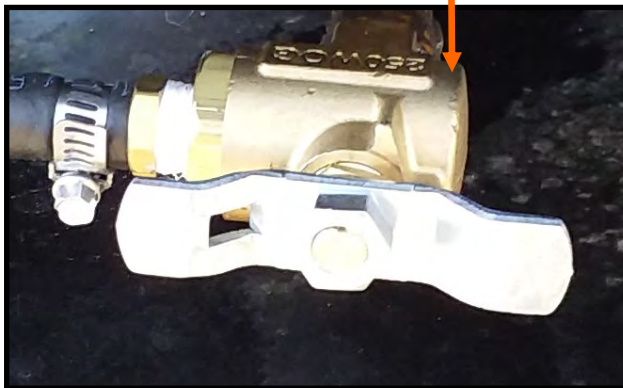

Fuel Shut Off Valve

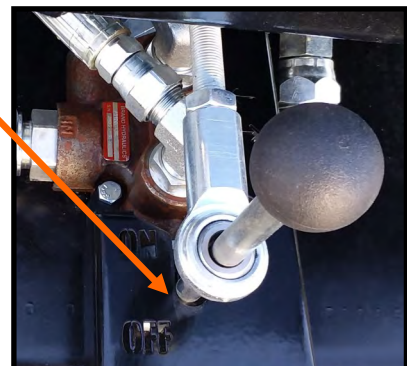

ON/Off Conveyor Control

GAS POWERED HYDRAULIC POWER PACK

3. To start a cold engine, pull the choke knob out to the closed position
4. To start or restart a warm engine, leave the choke knob in to the open position.
5. Move the throttle lever away from the min position, about 1/3 of the way towards the max position.
6. Turn the engine switch to the on position.
7. Operate the starter . Turn the engine switch to the start position and hold it there until the engine starts. If the engine fails to start within 5 seconds, release the engine switch, and wait at least 10 seconds before operating the starter again. (using the electric starter for more than 5 seconds at a time will overheat the starter motor and damage it.)

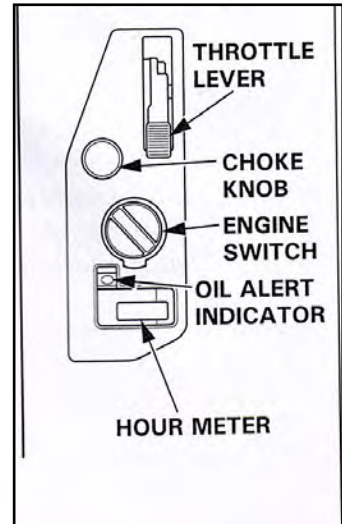

8. When the engine starts, release the engine switch, allowing it to return to the on position.
9. Position the throttle lever to the desired speed. It is recommended between half and three-quarters speed.
10. Move the conveyor control to the on position.

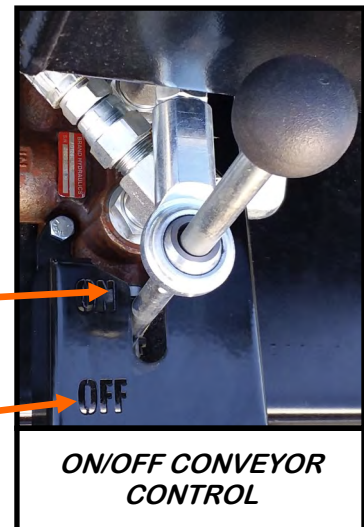

STOPPING THE ENGINE

1. Move the conveyor lever to the OFF position.
2. Move the throttle lever to the min position.
3. Turn the engine switch to the off position.
4. Close the shut off valve on the fuel tank.

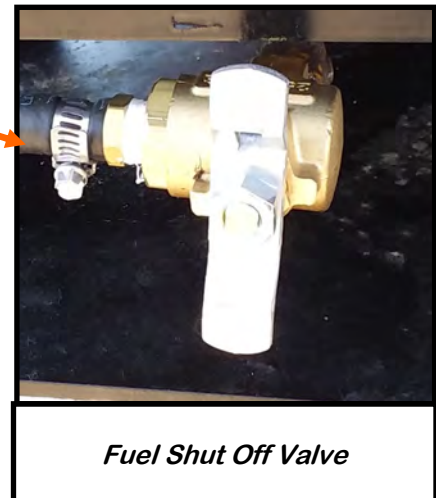

SELF-MOVER

This option is currently only available as factory installed. There are two options: 1) Undercarriage, and 2) Trailer.

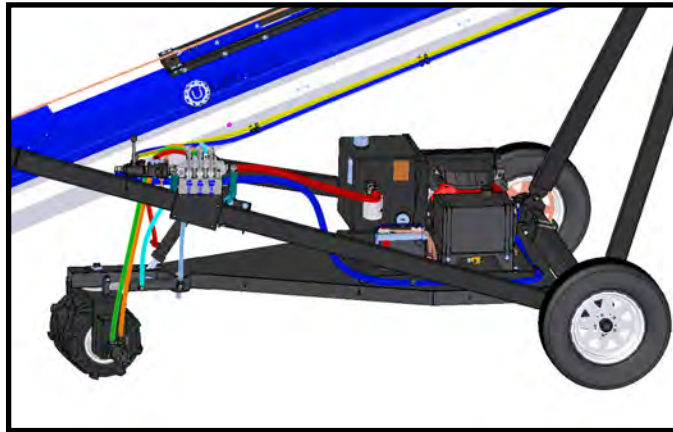

Self-Mover on Undercarriage

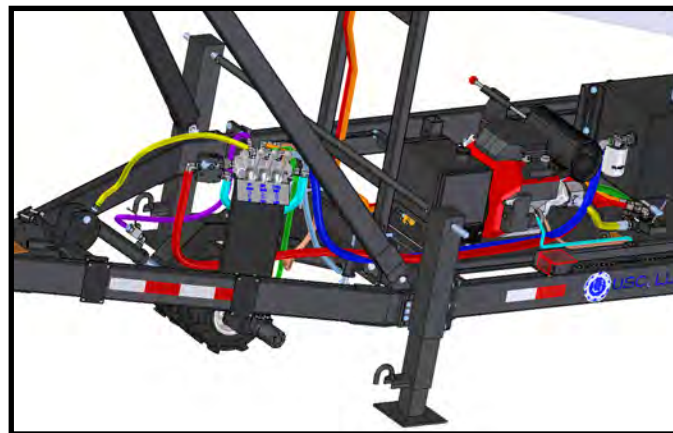

Self-Mover on Trailer



Always clear area of bystanders. In the event anyone enters the danger area, stop and do not proceed until they have left the danger area.

FIELD LOADER CONVEYOR

1. **DRIVE UNIT UP / DOWN:** To raise or lower the drive unit use lever 1.
2. **FORWARD / REVERSE CONTROL:** To move the conveyor forward or backward use lever 2.
3. **STEERING CONTROL:** To steer right or left use lever 3.
4. **SPEED CONTROL:** Adjust speed using the lever to the left of the panel. The higher the number the faster the conveyor will move. It is recommended that the conveyor be slowly moved to prevent tipping.

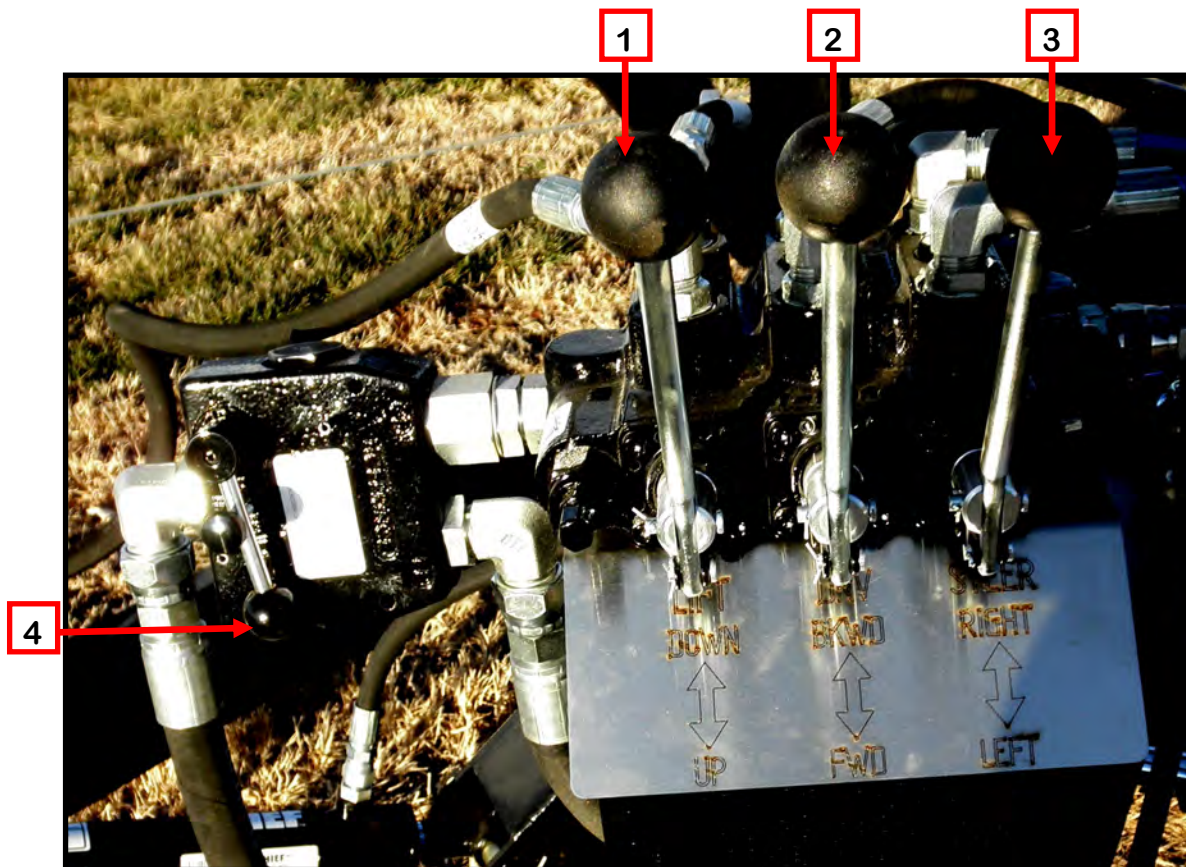

SELF-MOVER

1. Start the engine on the hydraulic power pack according to the instructions starting on page 38.
2. Open the valve on the lift cylinder.
3. Lower the drive unit so the jacks come up off the ground



DANGER

When moving the unit, the jacks need to be close to the ground to prevent tipping. The conveyor also needs to be resting on the support.

4. For trailer mounted system, lower and lock the rear wheels. See page 35.

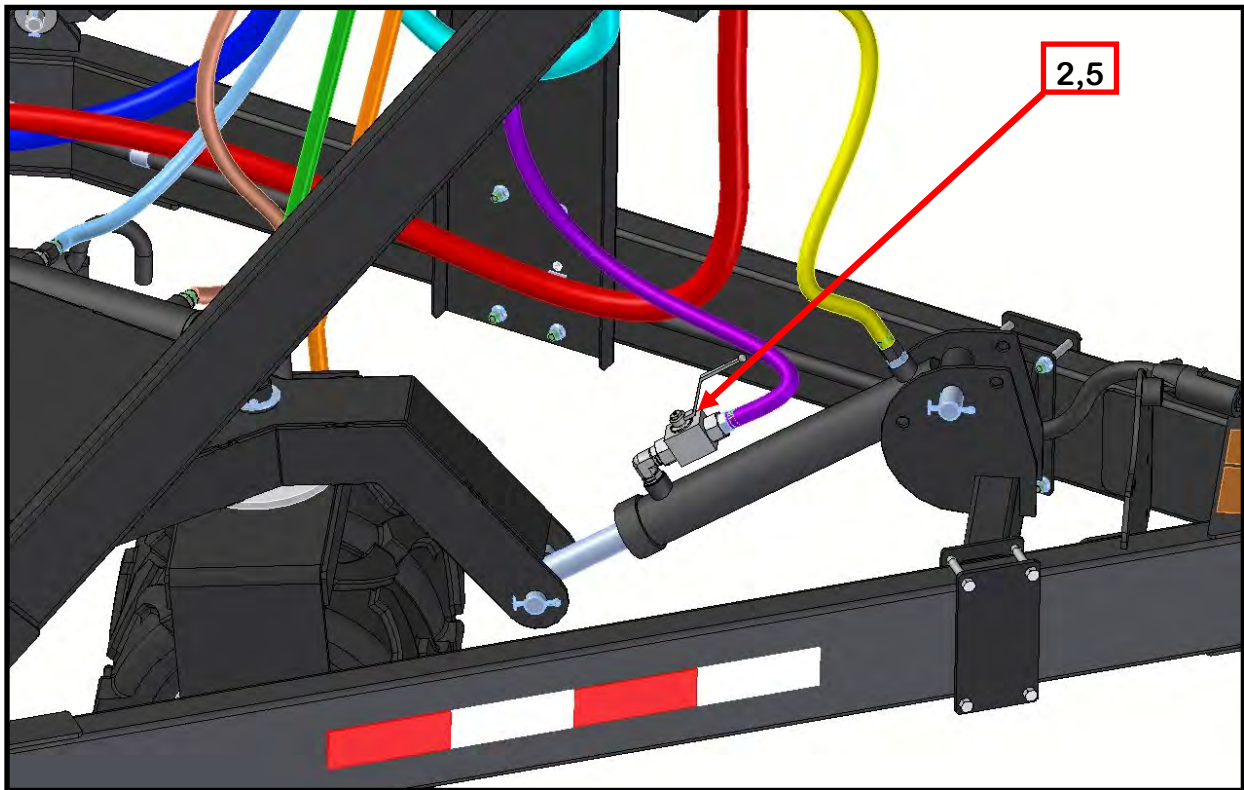

5. To transport the conveyor, raise the drive unit so conveyor is resting on the jacks. Close valve on lift cylinder and shut down the engine.
6. Do not exceed 25 mph on roads. Reduce speed on rough roads and surfaces.
7. Refer to page 11 for Transport Safety.

TROUBLESHOOTING SECTION D

Below is a table describing the most frequent problems and solutions with the Field Loader Conveyor. For further assistance, contact your authorized dealer.

Problem	Possible Cause	Solution
Conveyor will not run.	<ol style="list-style-type: none"> 1. Not turned on. 2. Conveying belt loose. 3. Drive belt loose. 	<ol style="list-style-type: none"> 1. Start power source or turn power on. 2. Tighten and align belt. 3. Tighten drive belt.
Conveyor will not run. (Hydraulic Motor)	<ol style="list-style-type: none"> 1. Tractor hydraulic pressure is to low. 2. Ball valve is in shut off position. 3. Hose disconnected. 	<ol style="list-style-type: none"> 1. Tractor hydraulic pressure needs to be 2400 PSI minimum. 2. Open valve. 3. Connect hose to tractor.
Belt edge fraying.	<ol style="list-style-type: none"> 1. Belt not aligned. 	<ol style="list-style-type: none"> 1. Align and tension belt.
Low conveying capacity.	<ol style="list-style-type: none"> 1. Angle too steep. 2. Conveyor belt slipping. 3. Drive belt slipping. 	<ol style="list-style-type: none"> 1. Reposition with angle at less than 25°. 2. Tighten belt. 3. Set drive belt tension.

SECTION
E**MAINTENANCE**

Proper maintenance of the Field Loader Conveyor is critical for peak performance, reliability and accuracy of this system. The following is a guideline for the type of maintenance and servicing that should be performed on this unit. Your environment and uses may require additional maintenance and service beyond this list to assure a reliable and safe unit. The operator of this unit has ultimate responsibility to identify areas of concern and rectify them before they become a hazard or safety issue. There is no substitute for a trained, alert operator.



Do not put this unit into operation with any questionably maintained parts. Poor performance or a hazard may occur.



Failure to maintain the proper belt tension will cause the belt to slip. This will damage the belt and head drive pulley. If the belt is not tracking correctly, it can ride along one edge causing the belt to fray and damage the belt splice. Either problem will cause the belt to burn or wear out prematurely.

FLUIDS AND LUBRICANTS**Grease**

Use an SAE multipurpose high temperature grease with extreme pressure (EP) performance. Also acceptable is an SAE multipurpose lithium-based grease.

Storing Lubricants

Your machine can operate at top efficiency only if clean lubricants are used. Use clean containers to handle all lubricants. Store them in an area protected from dust, moisture and other contaminants.

GREASING

Use a Maintenance Checklist to keep record of all scheduled maintenance.

1. Use a hand-held grease gun for all greasing.
2. Wipe grease fitting with a clean cloth before greasing to avoid injecting dirt and grit.
3. Replace and repair broken fittings immediately.

NOTICE

If fittings will not take grease, remove and clean thoroughly. Also clean lubricant passageway. Replace fitting if necessary.

CONVEYOR SERVICING INTERVALS

Every 40 hours or Weekly

1. Check the conveyor belt tension and alignment.
2. Grease conveyor bearings.
 - A. Two bolt flanged bearings, drive roller bearings right and left (2 locations) and s-drive.
 - B. Two bolt flanged bearings, s-drive bearings right and left at the transition (2 locations).
 - C. Two bolt flanged bearings, tail roller bearings right and left (2 locations).
3. Remove guard and check the drive belt tension and alignment. The belts will deflect approximately 1/4 to 1/2 inch when properly tensioned.

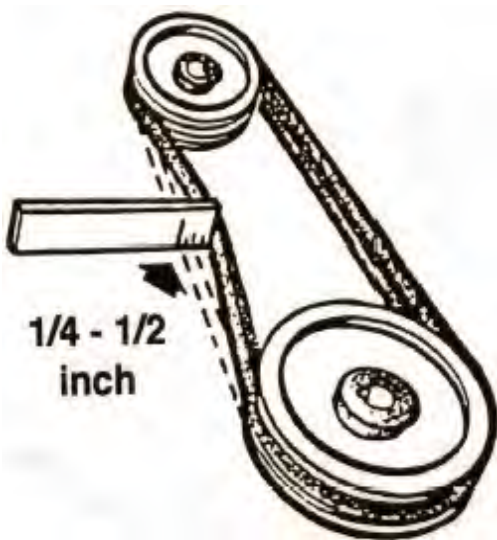

Every 200 hours or Annually

1. Wash machine.
2. Check pulley bushing for wear. To inspect pulley:
 - A. Loosen and remove the bolt.
 - B. Inspect the bushing on the pulley for wear.
 - C. Reverse steps A and B for re-assembly.

CONVEYING BELT TENSION AND ALIGNMENT - INLET END

A contoured chevron belt is used to convey material along the frame. The tension and alignment of the belt should be checked weekly, or more often if required, to be sure that it does not slip or run to one side. A properly tensioned belt will not slip when it is operating. Operating the belt with less slippage will increase the belt life and causes less stress on bearings, pulleys and shafts.

WARNING

Although it is acceptable to align the belt from either the Head or the Tail end. Tightening the belt may only be done from the Tail end of the conveyor

To maintain the belt, follow this procedure:

NOTICE

Place all controls in neutral or off, stop motor and disable power source before working on belt.

1. Use the take-up bolt located at the tail to set the tension of the belting.
2. If the belt needs to be tightened to prevent slippage, use the take-up adjustments on the tail end only.
3. The belt is tightened by turning both take-up adjustments an **equal** number of turns.
4. Use the drive roller to check the alignment. The belt should be centered.
5. Turn the belt 1/2 revolution when the belt is new and check the drive and tail roller. If out of alignment, the belt will move to the loose side. Loosen the jam nut and use the bearing position bolts to set the position. Tighten jam nut.
6. Run and check again. Check frequently during the first few minutes of operation and then several times during the first 10 hours. The belt normally seats itself during the first 10 hours of operation and can be checked weekly after that.
7. The belt is properly aligned when the belt runs in the center of the head and tail rollers.

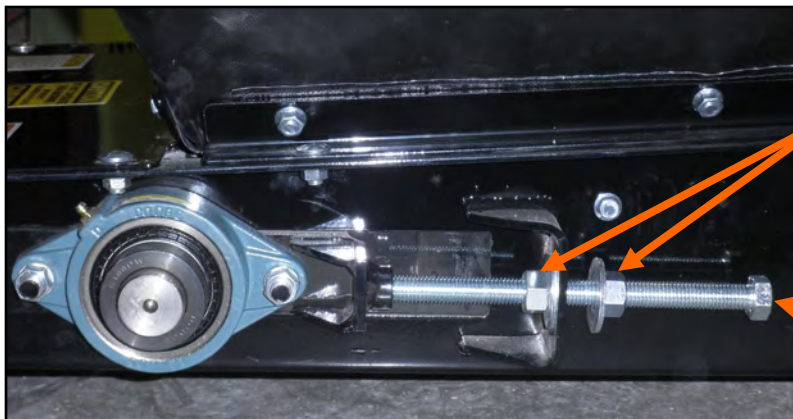

Loosen the jam nuts before adjusting the bearing position bolt

Use this bolt to tighten and align the belt

S-DRIVE ALIGNMENT

1. A misaligned belt will track toward the loose side.
2. Set the tracking by loosening the jam nut on the right side and using the bearing position bolt to move the end of the roller. Tighten the jam nut when the belt is centered on the roller.
3. Run the belt and check the tracking again. Loosen the tight side slightly again if required. Repeat the adjusting and checking procedure until the belt centers on the input end roller and remains centered when running.
4. Always repeat this aligning procedure when installing a new belt. Check frequently during the first 10 hours of operation. After 10 hours, the belt is normally seated and checking the alignment can be done less frequently.

NOTICE

Place all controls in neutral or off, stop motor and disable power source before working on belt.

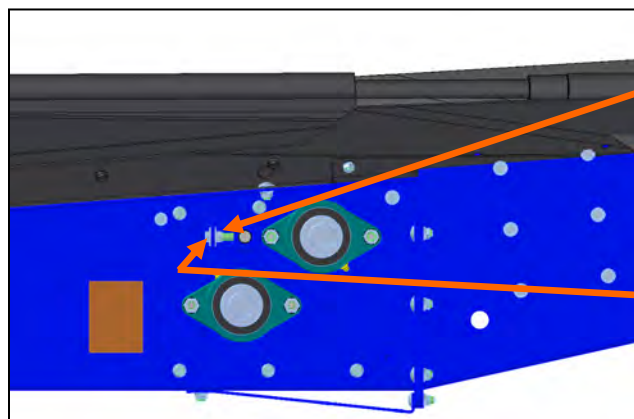

Loosen the jam nut before adjusting the bearing position bolt

Use this bolt to tighten and align the belt

CONVEYING BELT ALIGNMENT - HEAD END

1. A misaligned belt will track toward the loose side. Set the tracking by loosening the bearing mounts on the tight side and using the bearing position bolt to move the end of the head roller toward the tail. Tighten the bearing mount when the belt is centered on the head roller.
2. Run the belt and check the tracking again. Loosen the tight side slightly again if required. Repeat the adjusting and checking procedure until the belt centers on the inlet end roller and remains centered when running.
3. Always repeat this aligning procedure when installing a new belt. Check frequently during the first 10 hours of operation. After 10 hours, the belt is normally seated and checking the alignment can be done less frequently.

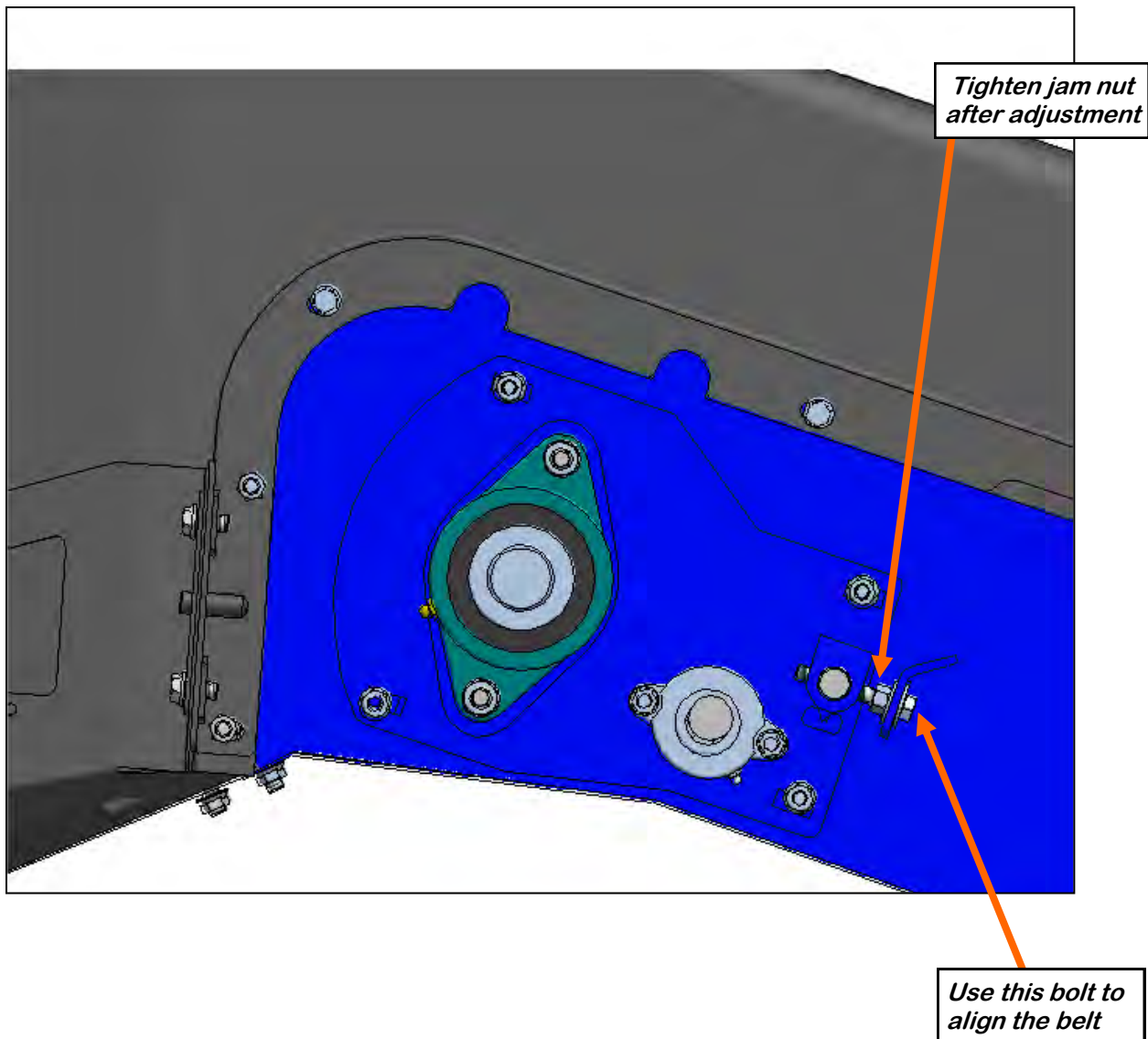

BELT REPLACEMENT

1. Remove the inlet hopper from the tail section. Rotate the belt until the seam is visible.
2. Move the tail roller to its loosest position.
3. Pull all the slack to the seam area.
4. Remove the wire connector and open the belt.
5. Attach one end of the replacement belt to the belt end being removed.
6. Pull the old belt out and the new belt will be threaded into place.
7. Disconnect the old belt.
8. Connect the ends of the new belt together and secure.
9. Set the belt tension.
10. Check and set the belt alignment.



Belt Seam

DRIVE BELT TENSION & ALIGNMENT

Power to the conveying belt is transmitted through a V-belt. The V-belt drive system must be maintained at the proper belt tension and pulley alignment to obtain the desired performance and life. When maintaining the belt drive system for the electric drive model, follow this procedure:

NOTICE

Turn motor off and unplug power cord or turn off power and lock out the master panel before starting maintenance on drive belt system.

Drive Belt Tension

1. Push on the center of the belt span with a force of approximately 5 to 10 lbs.
2. Follow the belt tensioning specification on page 52 to determine proper belt deflection.
3. Move the motor up, using the adjustment bolts, to set drive belt tension (right).
4. Close and secure guards.

Drive Belt Alignment

1. Lay a straightedge across the pulley faces to check the alignment (right).
2. Use the pulley hub or the motor mounting plate slots to move the pulley to the required position for alignment.
3. Tighten hub bolts to secure pulley on shaft.
4. Check belt tension
5. Close and secure guards.

Drive Belt Replacement

1. Lower motor to its lowest position.
2. Remove old belt and replace with a new one.
3. Raise motor to set the belt tension.
4. Check pulley alignment. Adjust if required.
5. Close and secure guards.



Motor Base Adjustment



Lay a Straightedge Across Pulley Faces

FIELD LOADER CONVEYOR

V-Belt tensioning adjustment can be made using a tension meter or other type spring scale using the following procedure. After seating the belts in the groove and adjusting center distance so as to take up the slack in the belts, further increase the tension until only a slight bow on the slack side is apparent while the drive is operating under load. Stop the drive and using the meter, measure the force necessary to depress one of the center belts 1/64 inch for every inch of belt span (see sketch below). For example, a deflection for a 50 inch belt span is 50/64 or 25/32 inch. The amount of force required to deflect the belt should compare with the deflection forces noted in the table below. Also notice for V- Belts that deflection forces vary from the initial RUN - IN values which are greater (reflecting higher run-in tensioning) to the NORMAL values for after the run-in period.

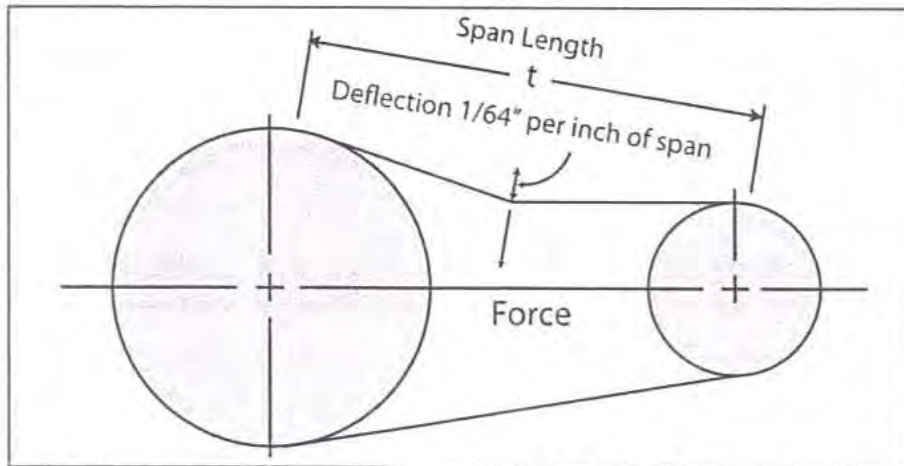

MEASURE THE SPAN LENGTH "T" AS SHOWN IN THE SKETCH ABOVE.

BELT CROSS SECTION	SMALLER PULLEY DIAMETER RANGE (inches)	DEFLECTION FORCE	
		RUN - IN (lbs.)	NORMAL (lbs.)
AX	3.0 - 3.6	4 - 1/8	2 - 3/4
	3.8 - 4.8	5	3 - 1/4
	5.0 - 7.0	6	4
BX	3.4 - 4.2	5 - 1/4	3 - 1/2
	4.4 - 5.2	7 - 1/8	4 - 3/4
	5.4 - 9.4	9	6

ENGINE MAINTENANCE

For engine maintenance information, please refer to the Honda Owner's Manual.

**SECTION
F****STORAGE**

When storing the Field Loader Conveyor for long periods of time, the following procedure must be followed to reduce the chance of rust, corrosion and fatigue of the conveyor. You can also use these steps when storing the machine for the winter.



A dust mask and protective rubber gloves shall be used when cleaning the machine.

1. Clear the area of bystanders, especially small children.
2. Thoroughly wash the entire machine to remove all dirt, mud, debris or residue.
3. Inspect all moving or rotating parts to see if anything has become entangled in them. Remove the entangled material.
4. Lubricate all grease fittings. Make sure that all grease cavities have been filled with grease to remove any water residue from the washing. This also protects the bearing seals.
5. Remove drive assembly cover. Clean entire area and ensure drive belt is clean and free of debris.
6. Touch up all paint nicks and scratches to prevent rusting.
7. Select an area that is dry, level and free of debris.
8. If possible, store the machine inside a protective building to keep it from being exposed to the weather. If storing outside, cover the entire machine with a large waterproof tarpaulin. If you do not have one large enough, at a minimum cover all electric motors.
9. Store machine in an area away from human activity.
10. Do not allow children to play on or around the stored machine.

FIELD LOADER CONVEYOR

NOTES:

SECTION
G**USC LIMITED WARRANTY**

Rev II 01AUG20

USC, LLC, (Manufacturer) warrants its seed treating equipment as follows:

1. Limited Warranty: Manufacturer warrants that the Products sold hereunder will be free from defects in material and workmanship for a period of 18 months from date of shipment. Manufacturer further provides a 12 month warranty on specific equipment supplied with a warranty card. The 12 month warranty begins upon USC receipt of warranty card from Wholesaler and must be submitted to USC within 18 months of stock equipment purchase by wholesaler to be valid. If the Products do not conform to this Limited Warranty during the warranty period, consumer shall notify Manufacturer in writing (on the approved USC warranty claim form) of the claimed defects and demonstrate to Manufacturer satisfaction that said defects are covered by this Limited Warranty (through pictures, video or other objective data). If the defects are properly reported to Manufacturer within the warranty period, and the defects are of such type and nature as to be covered by this warranty, Manufacturer shall, at its expense, furnish replacement Products or, at Manufacturer's option, replacement parts for the defective products. Shipping and installation of the replacement Products or replacement parts shall be at the Consumer's expense. All replacement parts orders through USC will carry their specific manufacturer's standard warranty including serialized parts manufactured by USC. USC will not warrant parts outside of the standard USC warranty period. USC will not extend any warranty due to replaced parts. The end user is responsible for all shipping and handling expenses for parts returned to USC under this section which may or may not be included in that specific warranty. USC will pay shipping expense between USC's vendor and USC.

2. Other Limits: THE FOREGOING IS IN LIEU OF ALL OTHER WARRANTIES, EXPRESSED OR IMPLIED, INCLUDING BUT NOT LIMITED TO THE IMPLIED WARRANTIES OF MERCHANTABILITY AND FITNESS FOR A PARTICULAR PURPOSE. Manufacturer does not warrant against damages or defects arising from improper installation (where installation is by persons other than Manufacturer), against defects in products or components not manufactured by Manufacturer, or against damages resulting from such non-Manufacturer made products or components. Manufacturer passes on to the consumer the warranty it received (if any) from the maker of such non-Manufacturer made products or components. This warranty also does not apply to Products upon which repairs and / or modifications have been affected or attempted by persons other than pursuant to written authorization by Manufacturer. This includes any welding on equipment which could damage electrical components. Manufacturer does not warrant against casualties or damages resulting from misuse and / or abuse of Products, improper storage or handling, acts of nature, effects of weather, including effects of weather due to outside storage, accidents, or damages incurred during transportation by common carrier or Dealer/customer arranged freight. Any replacement or repair covered under this warranty will **not** extend the warranty period. The remainder of the manufacturer's warranty will remain in force until stated expiration from point of sale.

3. Exclusive Obligation: THIS WARRANTY IS EXCLUSIVE. The sole and exclusive obligation of Manufacturer shall be to repair or replace the defective Products in the manner and for the period provided above. Manufacturer shall not have any other obligation with respect to the Products or any part thereof, whether based on contract, tort, strict liability or otherwise. Under **no** circumstances, whether based on this Limited Warranty or otherwise, shall Manufacturer be liable for lost profits, lost revenue, lost sales (whether direct or indirect damages), incidental, special, punitive, indirect or consequential damages. Consumer shall make no claims for remuneration for any loss as a result of USC equipment and USC shall reject any and all claims that may arise as stated herein.

4. Other Statements: Manufacturer's employees or representatives' oral or other written statements do not constitute warranties, shall not be relied upon by consumer, and are not a part of the contract for sale or this limited warranty. The USC Warranty Manager is the final decision point for all warranty claims.

5. Return Policy: Approval is required prior to returning goods to Manufacturer irrespective of warranty claim. A restocking fee will apply to all goods that are returned in new, sellable condition. Items returned for warranty that are found to be in new, sellable condition (not failing) will remain the property of the consumer and warranty claim for such items will be denied. The consumer will have the ability to have part returned at the consumer's expense or restocked at 15% restocking fee less any USC paid freight for its return.

6. Entire Obligation: This Limited Warranty states the entire obligation of Manufacturer with respect to the Products. If any part of this Limited Warranty is determined to be void or illegal, the remainder shall remain in full force and effect.

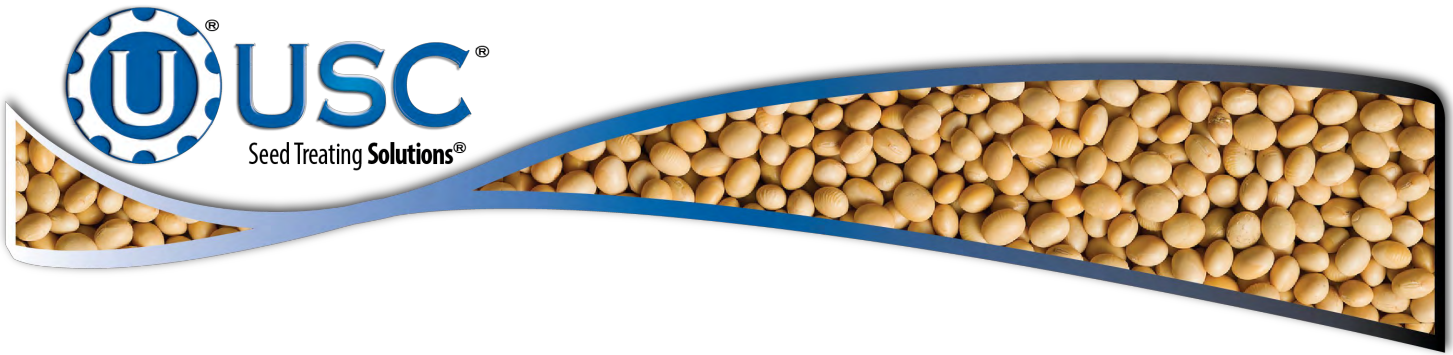

DOCUMENT REVIEW RECORD	
DATE	BY
07-2020	BT
01-2021	BT

USC, LLC

2320 124th Road

Sabetha, KS 66534

PHONE: (785) 431-7900

EMAIL: sales-team@uscllc.com

WEB: www.uscllc.com

