



SS16, TS25, TS35 CONVEYORS



Operators Manual

Document: TD-09-06-1060

Revision: C

Effective Date: 01-2021



INTRODUCTION

Thank you for choosing USC LLC for your equipment needs. We appreciate your business and will work diligently to ensure that you are satisfied with your choice.

OVERVIEW

The purpose of this manual is to provide you with the basic information needed to operate and maintain the USC conveyor. It does not hold USC LLC liable for any accidents or injuries that may occur.

The technical information provided in this document is based on extensive testing under controlled conditions at the USC research and development facility. This information is given without guarantee as the conditions of operation and storage of the equipment are beyond our control. Variables such as temperature, humidity, viscosity of chemical products and changes in seed size or variety may all effect the accuracy of application and seed coverage. Periodically check the equipment calibration while treating and make adjustments as required. This will insure the optimum seed coverage.

RECEIVING YOUR EQUIPMENT

As soon as the equipment is received, it should be carefully inspected to make certain that it has sustained no damage during shipment and that all items listed on the packing list are accounted for. If there is any damage or shortages, the purchaser must immediately notify USC LLC. Ownership passes to purchaser when the unit leaves the USC LLC premises. The purchaser is responsible for unloading and mounting all components of the equipment.

Document the serial number of the machine for future reference. The serial number is located on the right side of the conveyor near the inlet hopper.



SERIAL NUMBER: _____

TABLE OF CONTENTS

<u>Section</u>	<u>Contents</u>	<u>Page #</u>
Section A	Safety Instructions	4
	Safety Labels.....	12
Section B	Installation	17
	Undercarriage Assembly and Installation 20-35 Ft Conveyor .	18
	Electric Winch Installation 20 to 35 Ft.....	30
	Undercarriage Assembly and Installation 40-45 Ft Conveyor .	37
	Electric Winch Installation 40-45 ft.....	46
	Electrical Installation	52
	Conveyor Stand S-1	53
Conveyor Stand S-2 — S-5	54	
Section C	Mechanical Operation	56
	System Overview.....	57
	Controls.....	58
	Pre-Operation Checklist.....	59
	Conveyor Set Up	60
	Structural Envelope	61
	Machine Break-in.....	63
	Emergency Stopping.....	65
Restarting	65	
Section D	Transporting	67
Section E	Troubleshooting	69
	Unplugging.....	70
Section F	Maintenance	71
	Conveyor Servicing intervals	72
	Conveyor Belt Tension and Alignment—Tail End	73
	Conveyor Belt Alignment — Head End	75
	Belt Replacement	75
	Drive Belt Tensioning and Alignment.....	76
Belt Tensioning Specification.....	77	
Section G	Storage	78
Section H	Limited Warranty	80

SECTION A SAFETY INSTRUCTIONS

Every year accidents in the work place maim, kill and injure people. Although it may be impossible to prevent all accidents, with the right combination of training, operating practices, safety devices, and operator vigilance, the number of accidents can be significantly reduced. The purpose of this section is to educate equipment users about hazards, unsafe practices, and recommended hazard avoidance techniques.

If any of the required regularly scheduled maintenance is located above the reach of the operator, they should follow the companies normal safe practices of reaching that particular height, utilizing the companies specified equipment and following normal safety precautions.

When working with treatment chemicals, operators should always wear protective gloves, safety glasses, and follow the companies safety precautions in the case of any spillage or operator contamination.

SAFETY WORDS AND SYMBOLS

It is very important that operators and maintenance personnel understand the words and symbols that are used to communicate safety information. Safety words, their meaning and format, have been standardized for U.S. manufacturers and published by the American National Standards Institute (ANSI). The European Community (E.C.) has adopted a different format based on the International Standards Organization (I.S.O.) and applicable machinery directives. Both formats are presented below. Graphic symbols are not standardized, but most manufacturers will use some variation of the ones seen in this manual.



Indicates an imminently hazardous situation which, if not avoided, **will** result in death or serious injury.



Indicates a potentially hazardous situation which, if not avoided, **could** result in death or serious injury.



Indicates a potentially hazardous situation which, if not avoided, **may** result in minor or moderate injury and/or property damage.



Provides additional information that the operator needs to be aware of to avoid a potentially hazardous situation.



Notice is used to notify people of important installation, operation or maintenance information which is not hazard related.

USC CONVEYORS



Mandatory Lockout Power Symbol. Disconnect, lockout and tagout electrical and other energy sources before inspecting, cleaning or performing maintenance on this panel.



International Safety Alert Symbol. The exclamation point (!) surrounded by a yellow triangle indicates that an injury hazard exists. However, it does not indicate the seriousness of potential injury. The exclamation point (!) is also used with the DANGER, WARNING and CAUTION symbols so the potential injury is indicated.



Electrocution Hazard Symbol. This symbol indicates that an electrocution hazard exists. Serious injury or death could result from contacting high voltage.



International Electrocution Hazard. This symbol indicates that an electrocution hazard exists. Serious injury or death could result from contacting high voltage.



Mandatory Read Manual Action Symbol. (I.S.O. format) This symbol instructs personnel to read the Operators Manual before servicing or operating the equipment.



Mandatory Read Manual Action Symbol. This symbol instructs personnel to read the Operators Manual before servicing or operating the equipment.

LOCKOUT / TAGOUT PROCEDURES

Lockout/Tagout is the placement of a lock/tag on an energy isolating device in accordance with an established procedure. When taking equipment out of service to perform maintenance or repair work, always follow the lockout / tagout procedures as outlined in OSHA Standard 1910.147. This standard “requires employers to establish a program and utilize procedures for affixing appropriate lockout devices or tagout devices to energy isolating devices and to otherwise disable machines or equipment to prevent unexpected energizing, start-up, or release of stored energy in order to prevent injury to employees.”

HAZARD REVIEW

Electrocution Hazard



Electrocution accidents are most likely to occur during maintenance of the electrical system or when working on or near exposed high voltage wiring. This hazard does not exist when the electrical power has been disconnected, properly locked, and tagged out.

Automatic Start Hazard



This equipment may be controlled by an automated system and may start without warning. Failure to properly disconnect, lockout, and tagout all energy sources of remotely controlled equipment creates a very hazardous situation and could cause injury or even death. PLEASE STAY CLEAR AND BE ALERT.



USC CONVEYORS

YOU are responsible for the **SAFE** operation and maintenance of your USC LLC equipment . **YOU** must ensure that you and anyone else who is going to operate, maintain or work around the equipment be familiar with the operating and maintenance procedures and related **SAFETY** information contained in this manual. This manual will take you step-by-step through your working day and alert you to good safety practices that should be adhered to while operating the equipment

Remember, **YOU** are the key to safety. Good safety practices not only protect you, but also the people around you. Make these practices a working part of your safety program. Be certain that **EVERYONE** operating this equipment is familiar with the recommended operating and maintenance procedures and follows all the safety precautions. Most accidents can be prevented. Do not risk injury or death by ignoring good safety practices.

- Equipment owners must give operating instructions to operators or employees before allowing them to operate the machine, and at least annually thereafter per OSHA (Occupational Safety and Health Administration) regulation 1928.57.
- The most important safety device on this equipment is a **SAFE** operator. It is the operator's responsibility to read and understand **ALL** Safety and Operating instructions in the manual and to follow them. All accidents can be avoided.
- A person who has not read and understood all operating and safety instructions is not qualified to operate the machine. An untrained operator exposes himself and bystanders to possible serious injury or death.
- Do not modify the equipment in any way. Unauthorized modification may impair the function and/or safety and could affect the life of the equipment.
- Think SAFETY! Work SAFELY!

GENERAL SAFETY

1. Only trained persons shall operate the equipment . An untrained operator is not qualified to operate the machine.
2. Have a first-aid kit available for use should the need arise, and know how to use it.
3. Provide a fire extinguisher for use in case of an accident. Store in a highly visible place.
4. Do not allow children, spectators or bystanders within hazard area of machine.



USC CONVEYORS

5. Wear appropriate protective gear. This includes but is not limited to:

- A hard hat
- Protective shoes with slip resistant soles
- Protective goggles
- Heavy gloves
- Hearing protection
- Respirator or filter mask



6. Place all controls in neutral or off, stop motor, and wait for all moving parts to stop. Then disable power source before servicing, adjusting, repairing, or unplugging.

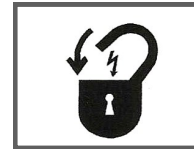

7. Review safety related items annually with all personnel.

OPERATING SAFETY:

1. Disconnect and disable electrical supply completely and wait for all moving parts to stop before servicing, adjusting, repairing or unplugging.
2. Clear the area of bystanders, especially children, before starting.
3. Be familiar with the machine hazard area. If anyone enters hazard area, shut down machine immediately. Clear the area before restarting.
4. Keep hands, feet, hair and clothing away from all moving and/or rotating parts.
5. Stay away from overhead obstructions and power lines during operation and transporting. Electrocutation can occur without direct contact.
6. Do not operate machine when any guards are removed.
7. Inspect welds and repair if needed.

TRANSPORT SAFETY

1. Read and understand ALL the information in the Operator's Manuals regarding procedures and SAFETY when moving or transporting the Conveyor.
2. Check with local authorities regarding Conveyor transport on public roads. Obey all applicable laws and regulations.
3. Always travel at a safe speed. Use caution when making corners or meeting traffic.
4. Make sure the SMV (Slow Moving Vehicle) emblem and all the lights and reflectors that are required by the local highway and transport authorities are in place, are clean and can be seen clearly by all overtaking and oncoming traffic.
5. Do not allow riders on the Conveyor or the towing vehicle when transporting.
6. Attach Conveyor to towing vehicle with a pin and retainer.
7. Lower Conveyor to its lowest position for transporting. Keep lift point at drawbar height.
8. Keep to the right and yield the right-of-way to allow faster traffic to pass. Drive on the road shoulder, if permitted by law.
9. Do not exceed 25 m.p.h. (40 km/h). Reduce speed on rough roads and surfaces.



10. Stay away from overhead obstructions and power lines when transporting. Electrocution can occur without direct contact.

11. Always use hazard warning flashers on tractor when transporting unless prohibited by law.

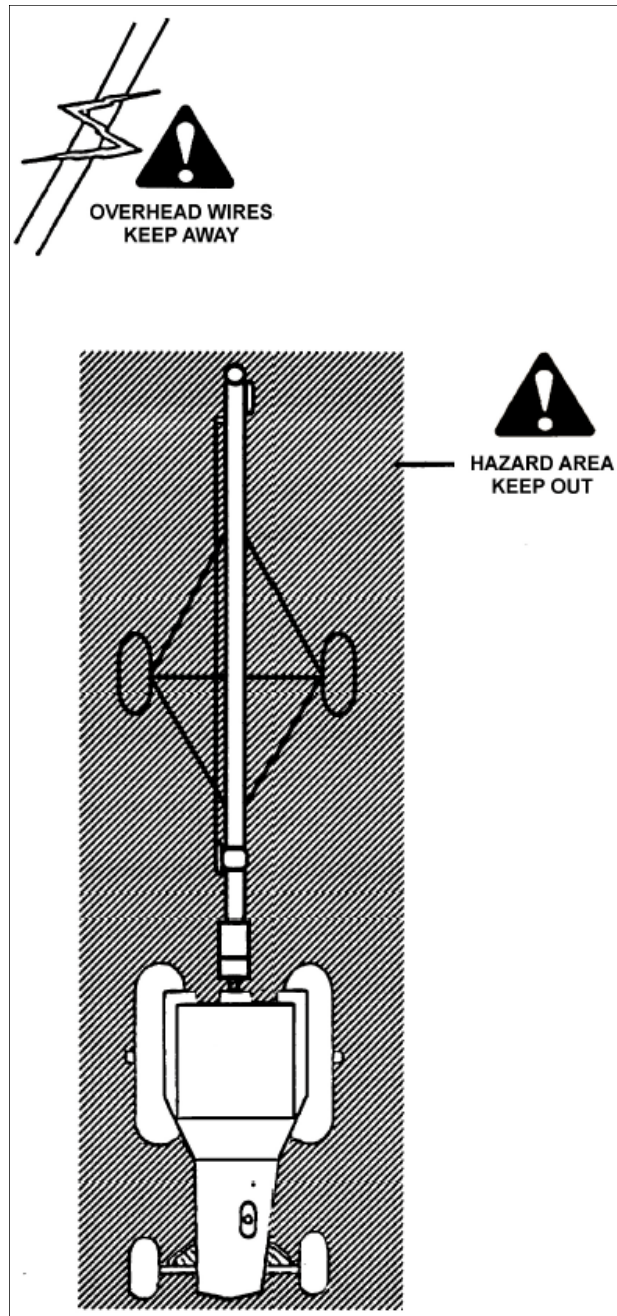

PLACEMENT SAFETY

1. Move only with the appropriate equipment



2. Stay away from overhead power lines when moving the Conveyor. Electro-cution can occur without direct contact.

3. Be familiar with machine hazard area. If anyone enters hazard areas, shut down machine immediately. Clear the area before restarting.

4. Operate the Conveyor on level ground free of debris. Anchor the Conveyor to prevent tipping or upending.



Before placement of the Conveyor, be sure that ground is reasonably level. The Conveyor may topple or work improperly if the ground is too uneven, damaging the equipment and/or causing personal injury.



When releasing the Conveyor from the towing vehicle, test the intake end for downward weight. Do not raise the intake end above drawbar height. When the intake end is elevated too high with machine in raise position, the balance of weight quickly transfers to the discharge end.

TIRE SAFETY

1. Failure to follow proper procedures when mounting a tire on a wheel or rim can produce an explosion which may result in serious injury or death.
2. Do not attempt to mount a tire unless you have the proper equipment and experience to do the job.
3. Have a qualified tire dealer or repair service perform required tire maintenance.
4. When replacing worn tires, make sure they meet the original tire specifications. Never undersize.

USC CONVEYORS

MAINTENANCE SAFETY

1. Review the Operator's Manual and all safety items before working with, maintaining or operating the Conveyor.
2. Place all controls in neutral or off, stop motors, disable power source, and wait for all moving parts to stop before servicing, adjusting, repairing or unplugging.
3. Follow good shop practices:
Keep service area clean and dry.
Be sure electrical outlets and tools are properly grounded.
Use adequate light for the job at hand.
4. Keep hands, feet, hair and clothing away from all moving and/or rotating parts.
5. Clear the area of bystanders, especially children, when carrying out any maintenance and repairs or making any adjustments.
6. Before resuming work, install and secure all guards when maintenance work is completed.
7. Keep safety signs clean. Replace any sign that is damaged or not clearly visible.



SAFETY LABELS

1. Keep safety labels clean and legible at all times.
2. Replace safety labels that are missing or have become illegible.
3. Replaced parts that displayed a safety label should also display the current label.
4. Replacement safety labels are available from your authorized dealer.

How to Install Safety Labels:

- Be sure that the installation area is clean and dry.
- Be sure temperature is above 50°F (10°C).
- Decide on the exact position before you remove the backing paper.
- Remove the smallest portion of the split backing paper.
- Align the sign over the specified area and carefully press the small portion with the exposed sticky backing in place.
- Slowly peel back the remaining paper and carefully smooth the remaining portion of the sign in place.
- Small air pockets can be pierced with a pin and smoothed out using the piece of sign backing paper.



Located on the USC equipment you will find safety labels. Always be sure to read and follow all directions on the labels.



Guards provided with USC equipment are to remain in place during operation.

Think **SAFETY!** Work **SAFELY!**

REMEMBER—If Safety Labels have been damaged, removed, become illegible, or parts replaced without safety labels, new labels must be applied. New safety labels are available your authorized dealer.

USC CONVEYORS



Part # 09-02-0008



Part # 09-02-0009

USC CONVEYORS

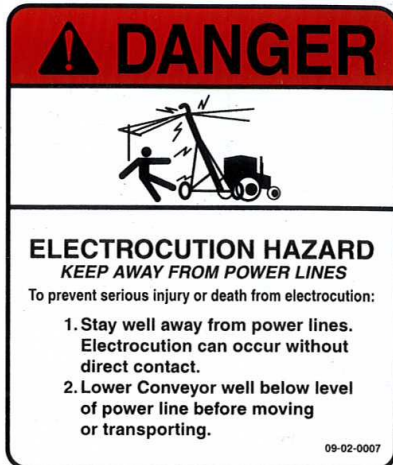
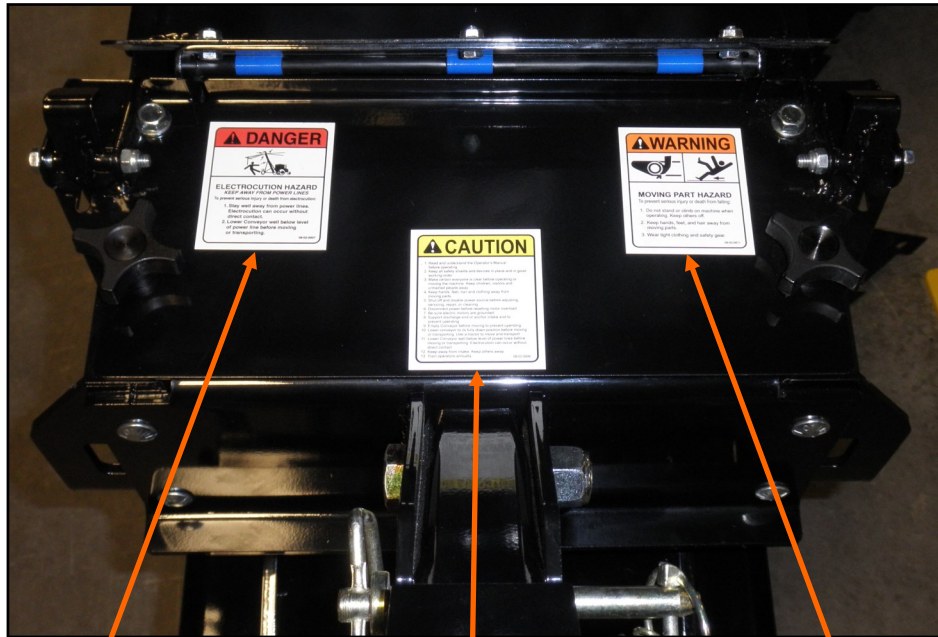

Part # 09-02-0007



Part # 09-02-0006



Part # 09-02-0011

USC CONVEYORS



! WARNING

MOVING PART HAZARD
To prevent serious injury or death from falling:

1. Do not stand or climb on machine when operating. Keep others off.
2. Keep hands, feet, and hair away from moving parts.
3. Wear tight clothing and safety gear.

09-02-0011

Part # 09-02-0011



! DANGER

ELECTROCUTION HAZARD
1. Turn machine OFF, shut down and lock out power source, unplug power cord and wait for all moving parts to stop before servicing or repairing electrical components.
2. Keep electrical components in good repair.

09-02-0010

Part # 09-02-0010



! DANGER

MISSING SHIELD HAZARD
Install and secure shield before operating.

09-02-0012

Part # 09-02-0012

USC CONVEYORS



Part # 09-02-0001



Part # 09-02-0002



HIGH VOLTAGE ~ Always disconnect the power source before working on or near the control panel or lead wires.



HIGH VOLTAGE ~ Use insulated tools when making adjustments while the controls are under power.

NOTICE

Permanent installation may require additional electrical cords, since each installation is unique.

UNDERCARRIAGE ASSEMBLY 20 - 35 FT CONVEYORS

The following instructions should be used to assemble your USC conveyor undercarriage. Hand tighten all fasteners until undercarriage is completely assembled.

NOTICE

The undercarriage for each length of conveyor (20 Foot to 35 Foot), has a unique assembly number and assembly part numbers.

1. Lay the Axle flat on the ground **(A)**.
2. Mount both tires **(B)**.
3. Assemble the upper arm weldments to the axle **(C)**.
4. Assemble the upper pulley cross member to both arms. Make sure the pulley is facing the axle and the horizontal edge of the bracket faces down. This will position the cable anchor on the correct side **(D)**.
5. Assemble the upper cross braces **(E)**.
6. Using the upper arm pin, assemble the Transport Slide. Secure the arm pin with two cotter pins on either end **(F)**.
7. Assemble the lower arm weldments to the axle **(G)**.
8. Assemble the lower cross braces **(H)**.
9. Tighten all of the fasteners.

UNDERCARRIAGE ASSEMBLY 20 - 35 FT CONVEYORS

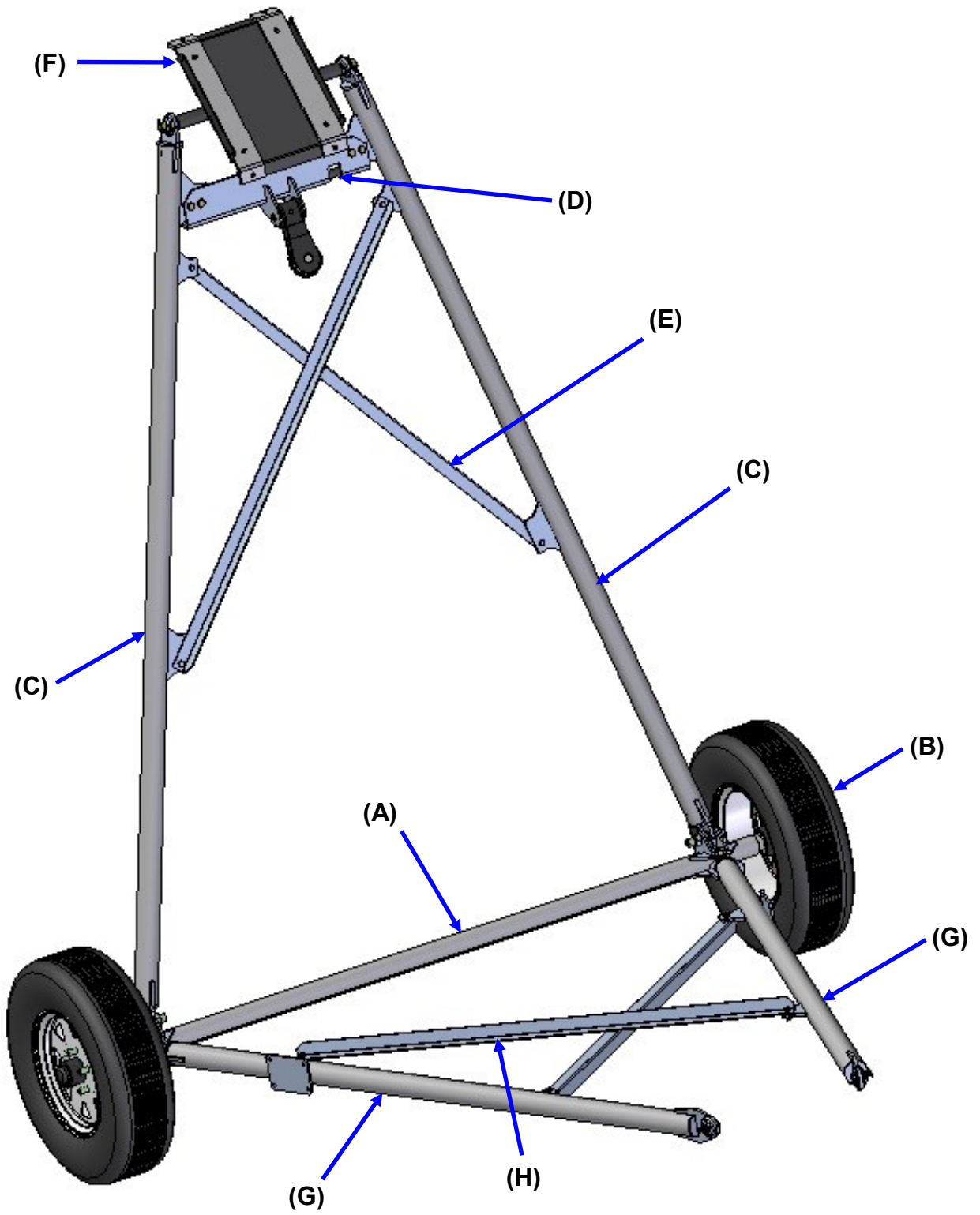

UNDERCARRIAGE AND BASE CONVEYOR ASSEMBLY 20 - 30 FT CONVEYORS

1. Using a forklift, pick up the base conveyor assembly in the center. Move conveyor the over the assembled undercarriage centering it. For more detailed part number information, refer to the installation document included in the parts bucket.
2. Mount the upper stop mounts using the holes designated in detail **A** (see pages 22—24).
3. Mount the lower stop mounts using the holes designated in detail **B** (see pages 22—24).
4. Lift the undercarriage slide until it is pressed firmly against the under side of the conveyor between the stop mounts.
5. Install the angle supports to capture the slide assembly.
6. Raise the lower arms until the swivel mounts line up with the holes on the splice mounting bracket. Insert the lower arm pin. Secure each end of the pin with a cotter pin.
7. Assemble the pivot pulley and the angled pivot pulley as shown in detail **C**.

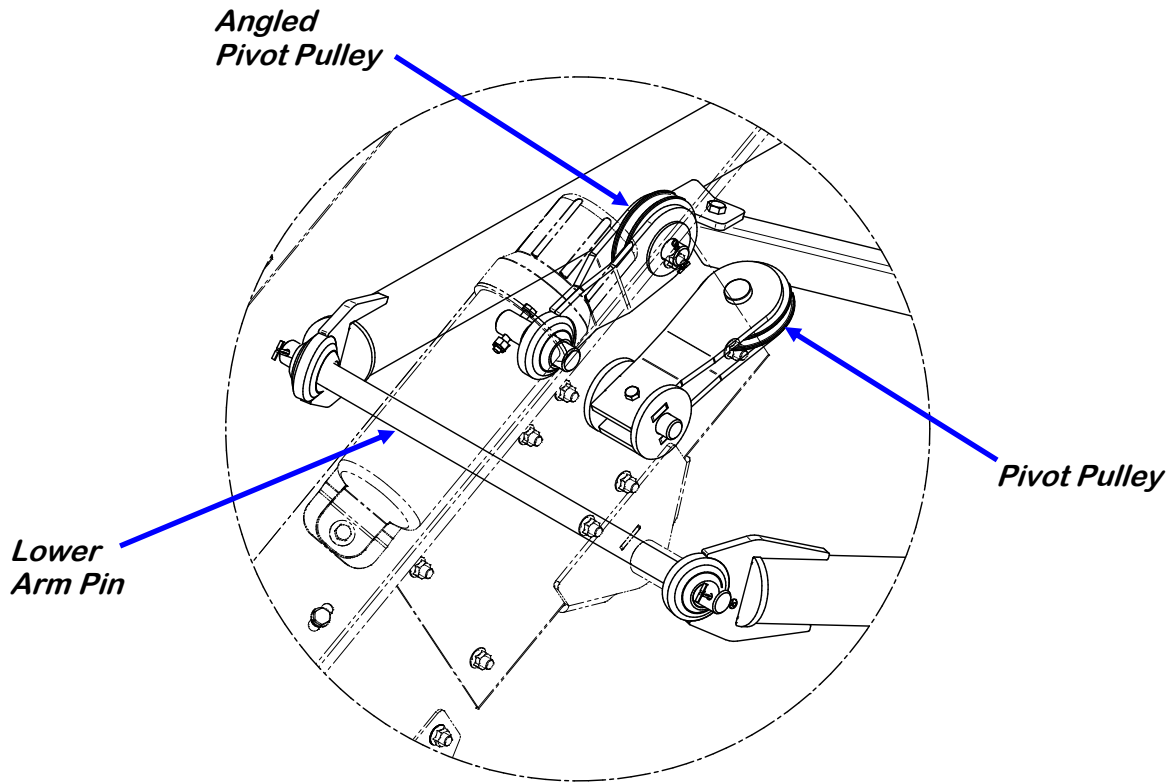

DETAIL C

UNDERCARRIAGE AND BASE CONVEYOR ASSEMBLY 20 - 30 FT CONVEYORS

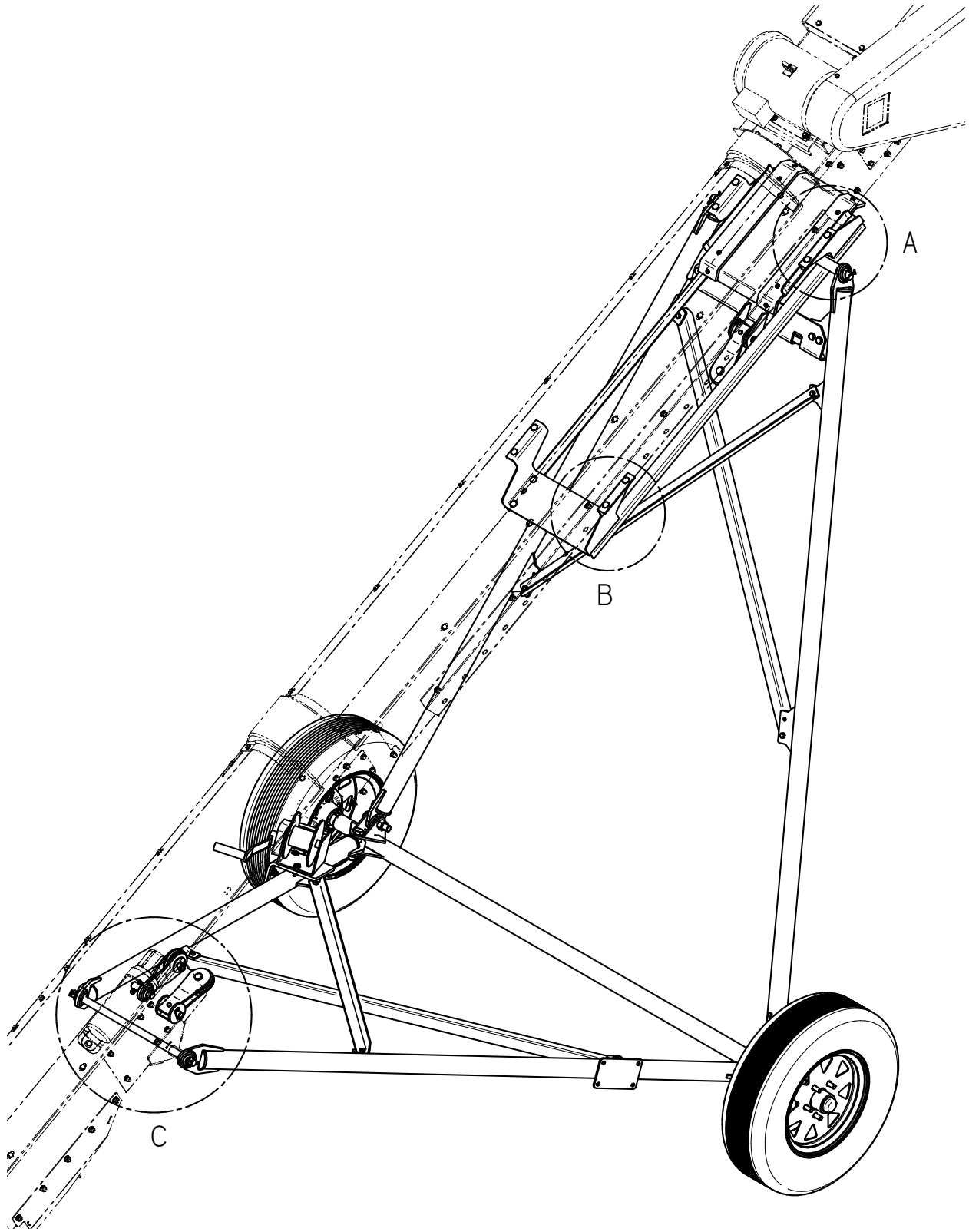

SLIDE MOUNT DETAILS 20 FT CONVEYOR

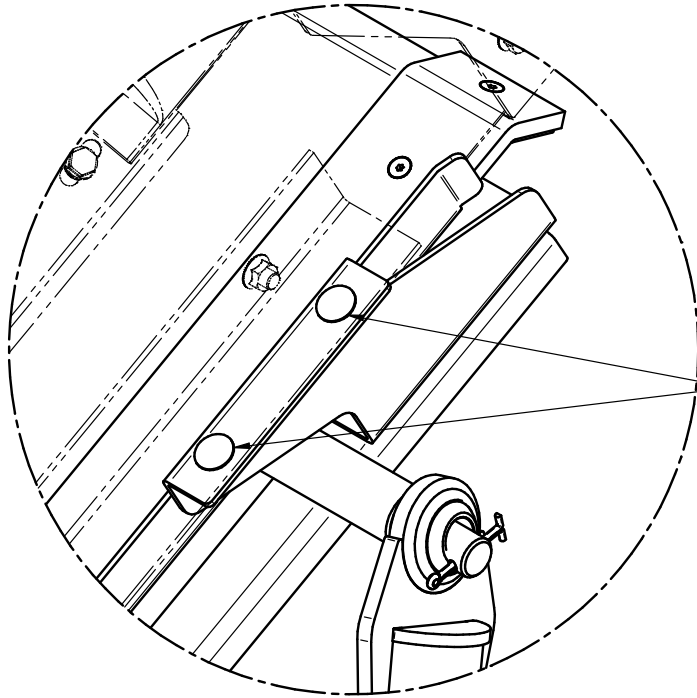

UPPER STOP MOUNTS IN
1ST & 2ND HOLES OF ANGLE

DETAIL A

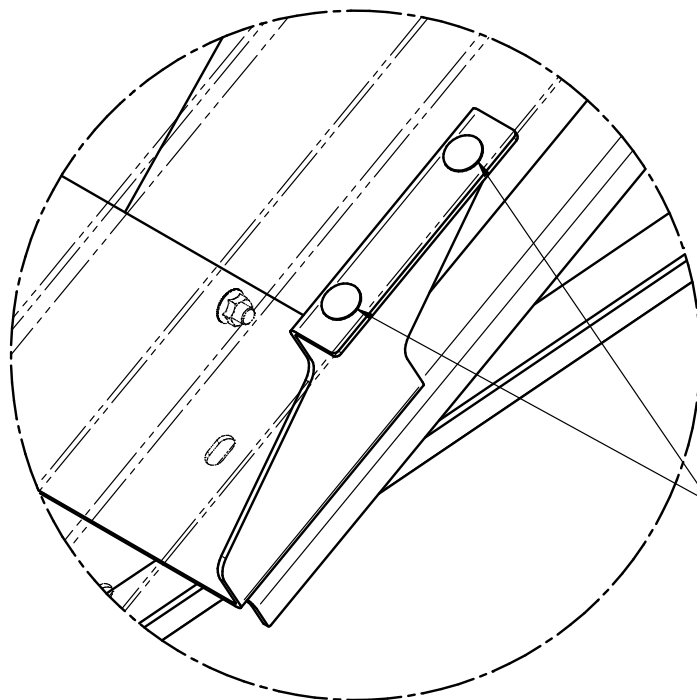

LOWER STOP MOUNTS IN
11TH & 12TH HOLES OF ANGLE,
FROM TOP.

DETAIL B

SLIDE MOUNT DETAILS 25 FT CONVEYOR

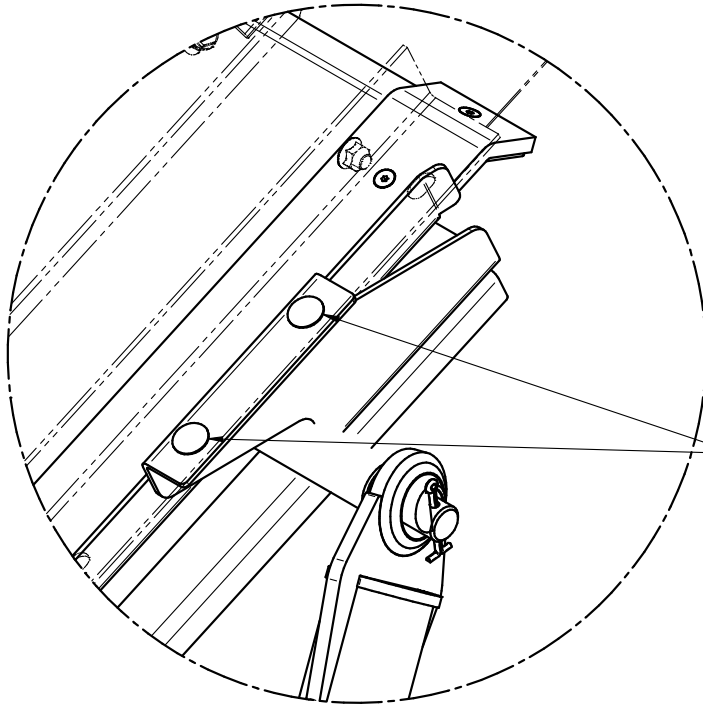

UPPER STOP MOUNTS IN
2ND & 3RD HOLES OF ANGLE.
FROM HEAD END

DETAIL A

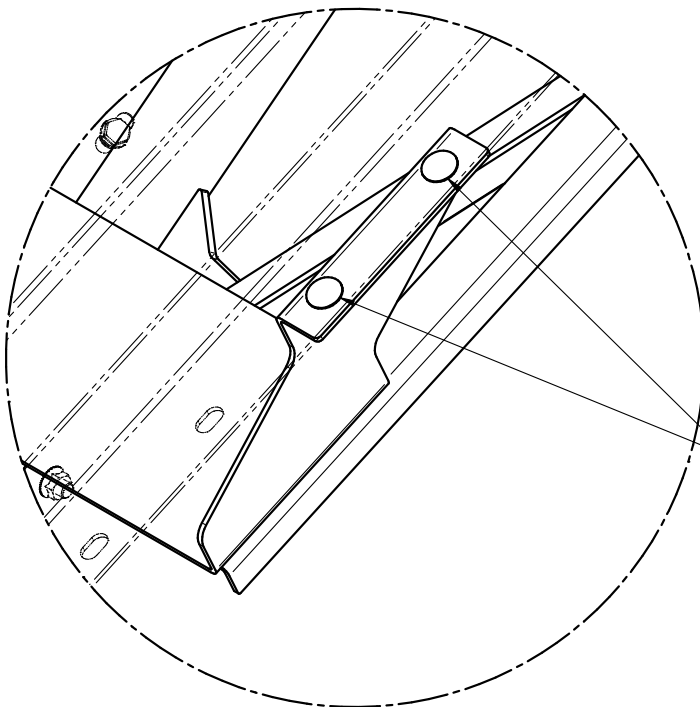

LOWER STOP MOUNTS IN
17TH AND 18TH HOLES OF
ANGLE, FROM HEAD END

DETAIL B

SLIDE MOUNT DETAILS 30 FT CONVEYOR

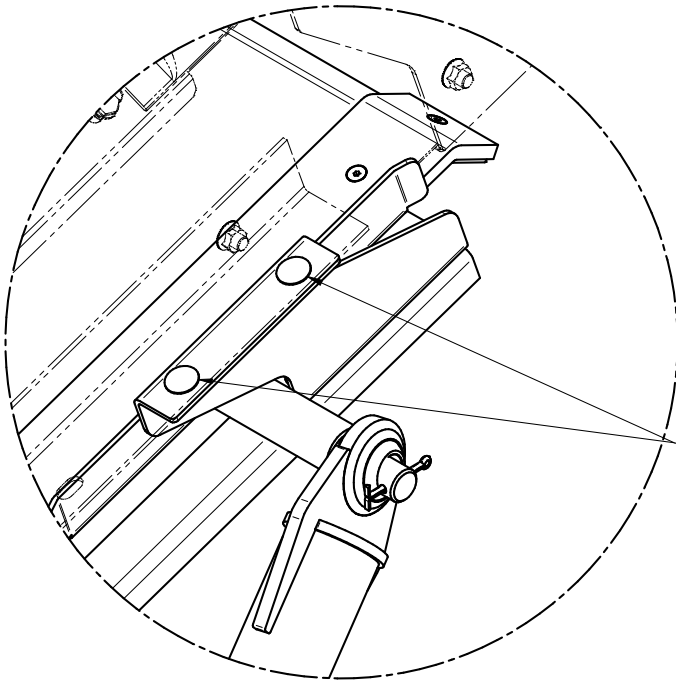

UPPER STOP MOUNTS IN
1ST & 2ND HOLES OF ANGLE
FROM HEAD END

DETAIL A

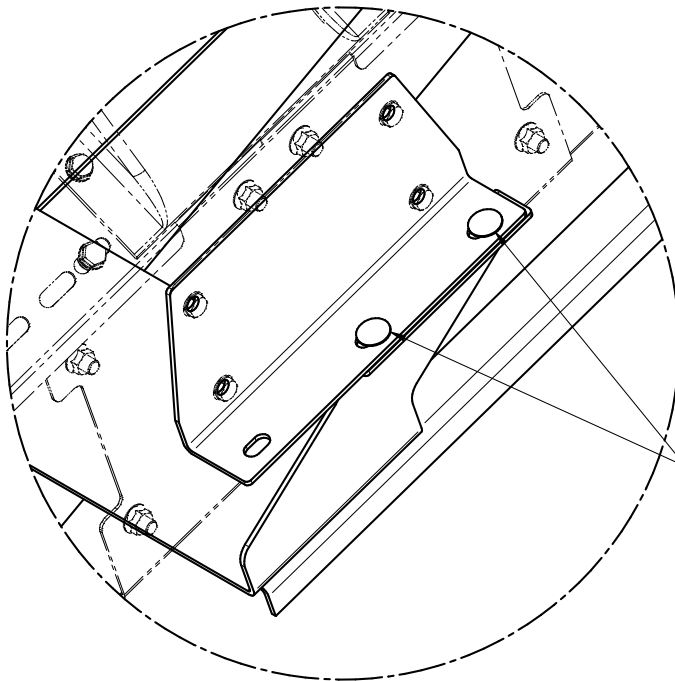

LOWER STOP MOUNTS ON 1ST AND 2ND
HOLES OF 05-10-4339 PLATE,
SPLICE COVER.

DETAIL B

UNDERCARRIAGE AND BASE CONVEYOR ASSEMBLY 35 FT CONVEYOR

1. Using a forklift, pick up the base conveyor assembly in the center. Move conveyor the over the assembled undercarriage centering it. For more detailed part number information, refer to the installation document included in the parts bucket.
2. Mount the upper stop mounts using the holes designated in detail **A** (see page 28).
3. Mount the lower stop mounts using the holes designated in detail **B** (see page 28).
4. Lift the undercarriage slide until it is pressed firmly against the under side of the conveyor between the stop mounts.
5. Install the angle supports to capture the slide assembly.
6. Raise the lower arms until the swivel mounts line up with the holes on the splice mounting bracket. Insert the lower arm pin. Secure each end of the pin with a cotter pin as shown in detail **C**.
7. Assemble the pivot pulley and the angled pivot pulley as shown in detail **C**.

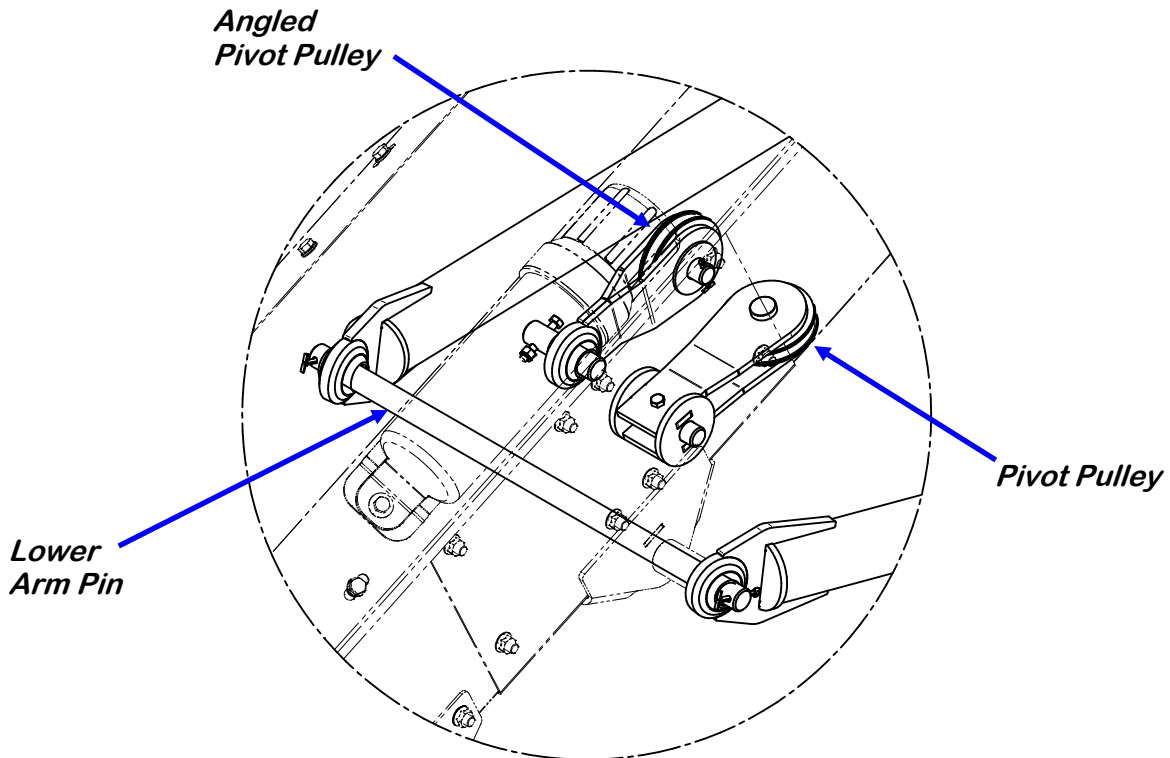

DETAIL C

UNDERCARRIAGE AND BASE CONVEYOR ASSEMBLY 35 FT CONVEYOR

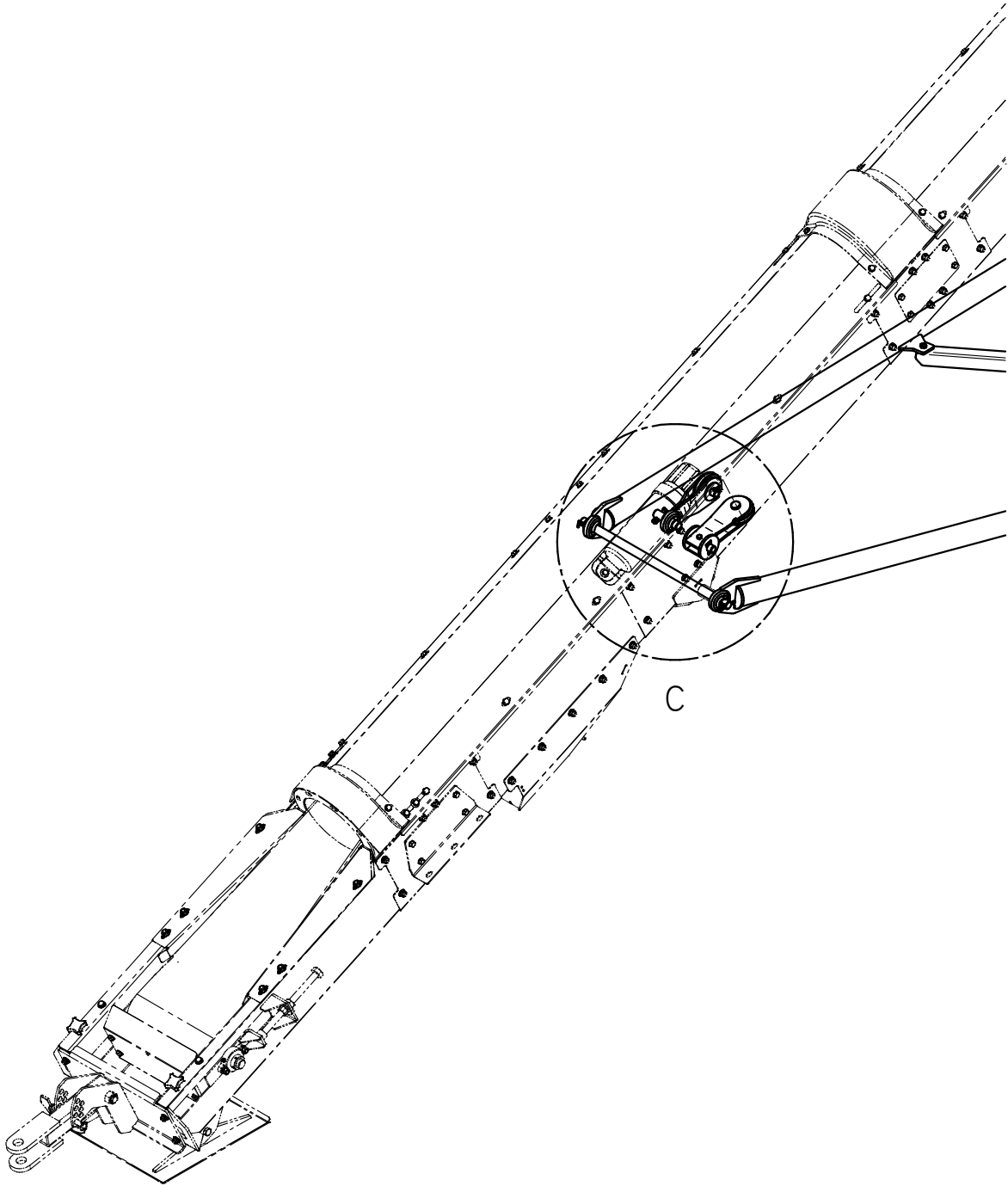

UNDERCARRIAGE AND BASE CONVEYOR ASSEMBLY 35 FT CONVEYOR

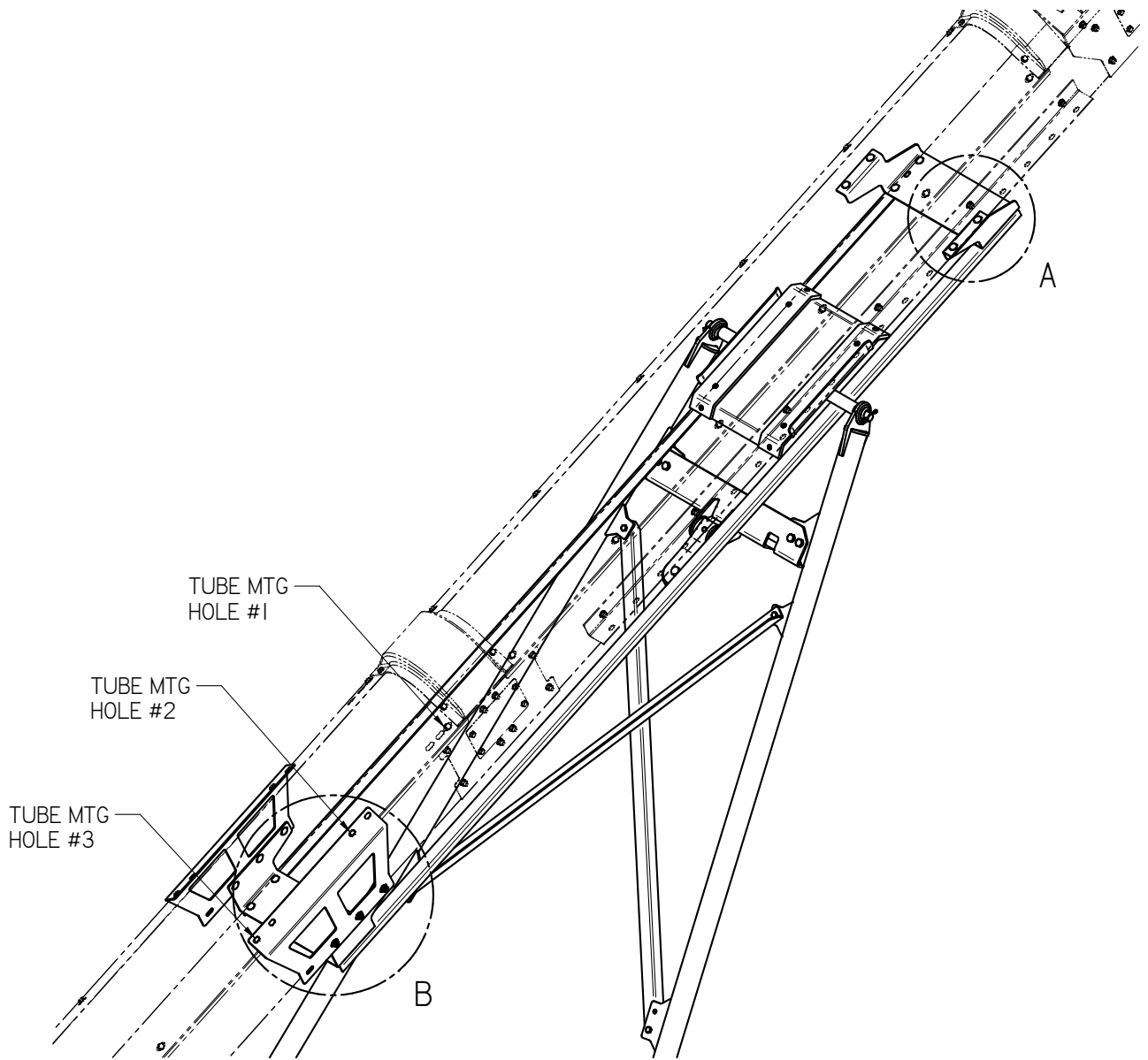

SLIDE MOUNT DETAILS 35 FT CONVEYOR

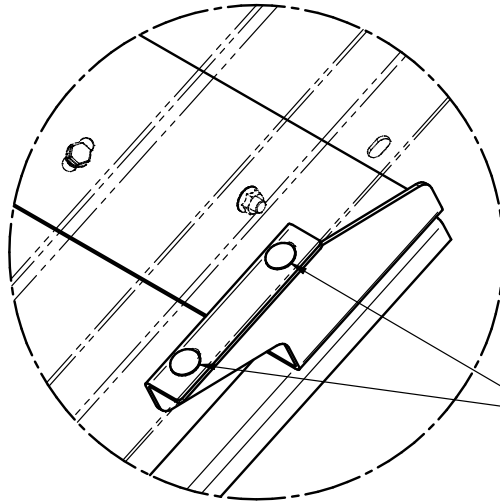

UPPER STOP MOUNTS IN
5TH & 6TH HOLES OF ANGLE
MOUNTS

DETAIL A

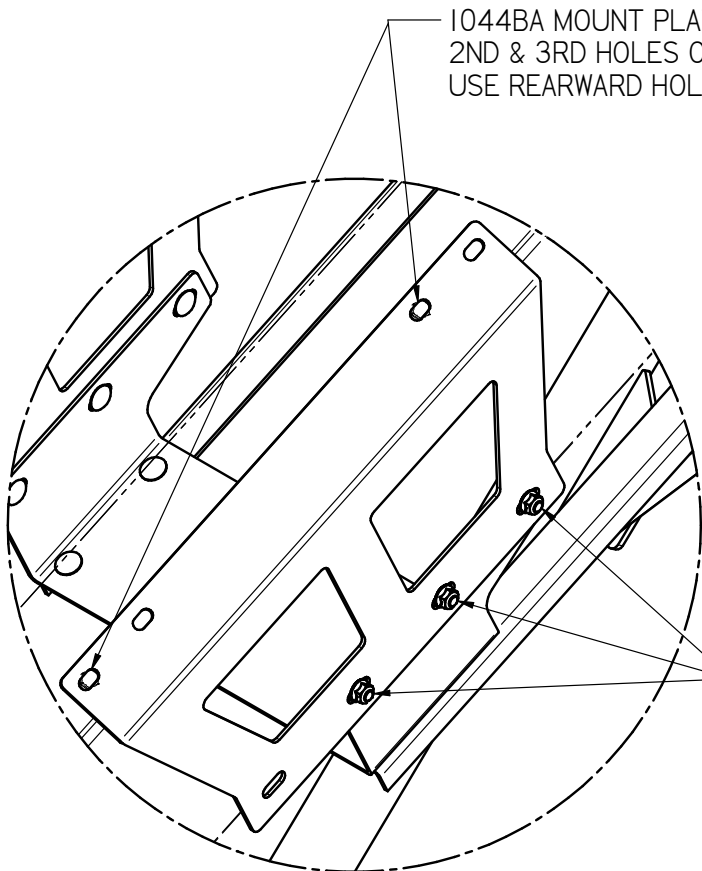

1044BA MOUNT PLATES MOUNT IN
2ND & 3RD HOLES OF TUBE WDMT.
USE REARWARD HOLES OF PLATE.

LOWER STOP MOUNTS IN
FORWARD 3 HOLES OF
1044BE MOUNT PLATE

DETAIL B

MANUAL WINCH AND CABLE INSTALLATION 20 - 35 FT CONVEYORS

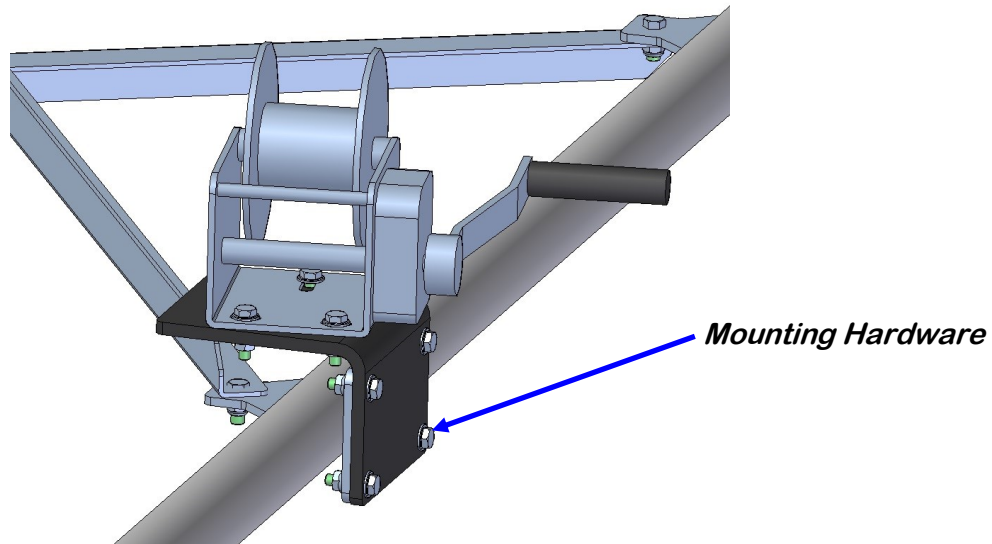

1. Mount the winch assembly to the lower arm using the hardware provided. Mount it so the winch is in on the inside of the arm as shown above. Adjust the winch so that the spindle directly faces the first pulley before tightening the three mounting bolts
2. Attach the cable to the crank.
3. Route the cable through the pulleys and attach to the undercarriage cable anchor following the path as shown in the illustration on page 30.
4. After cable has been run through the pulleys, terminate at the cable anchor on the upper cross member as shown below.

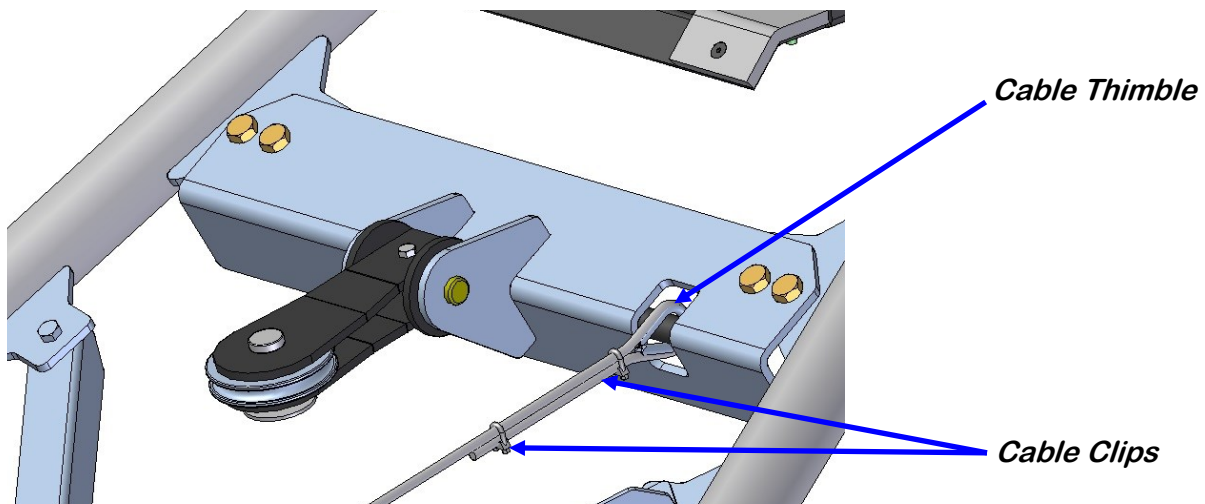

MANUAL WINCH CABLE ROUTING 20 - 35 FT CONVEYORS

5. Route the cable as shown on the view below in red. At each pulley, the cotter pin, clevis pin, washer and pulley must be removed. After placing the cable into the pully bracket, re-install pulley and hardware capturing the cable. Run the cable from the winch through the bottom pivoting pulley, through the top pulley, back down through the bottom non-pivoting pulley and terminate at the cable anchor.

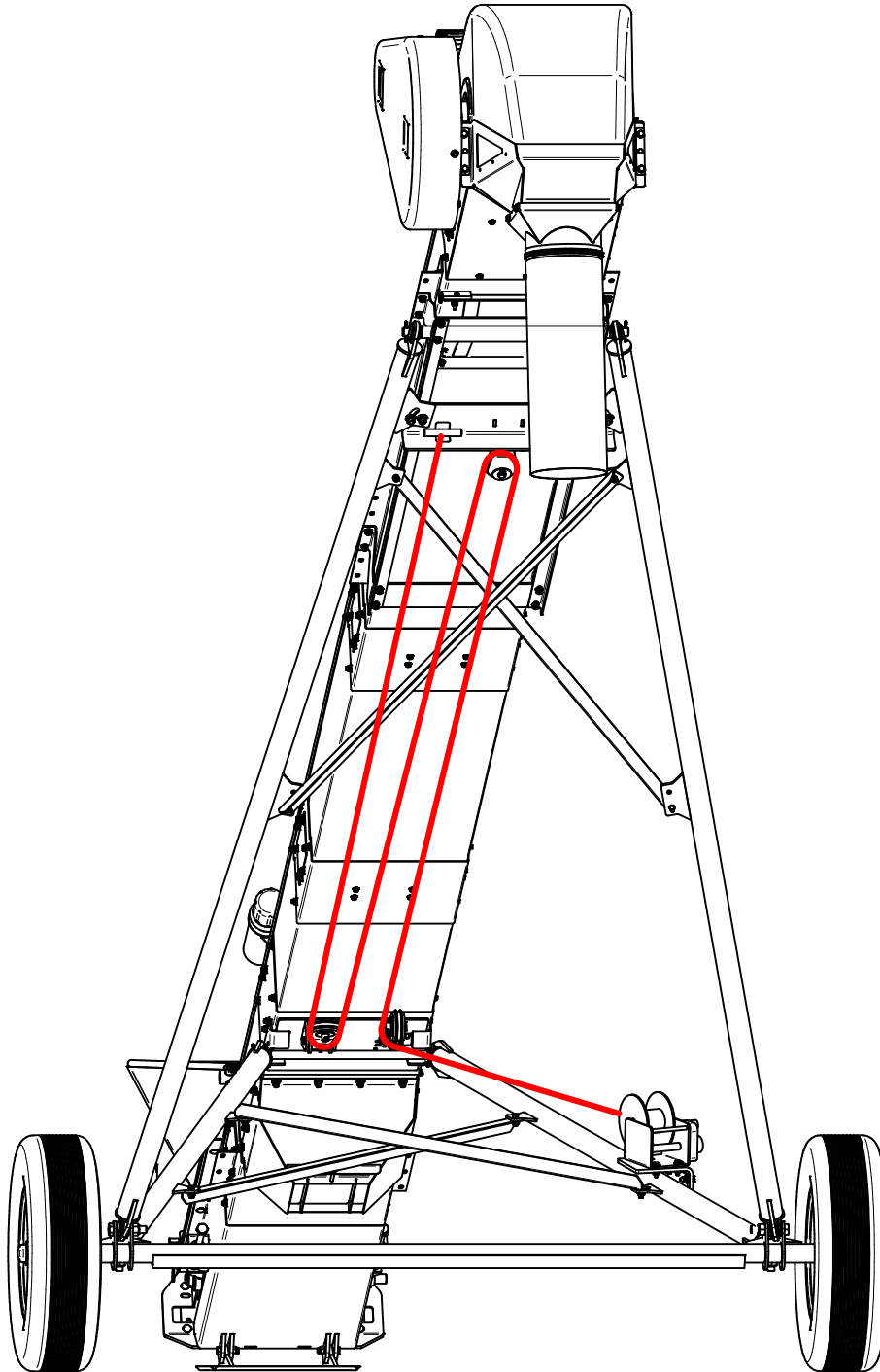

ELECTRIC WINCH AND CABLE KIT INSTALLATION (20 - 35 FT CONVEYORS)

NOTICE If electric winch kit was ordered at the same time as the conveyor, steps 1 through 4 will not be necessary.

1. Lower conveyor until slide is against upper stop. When fully lowered winch cable should be slack.

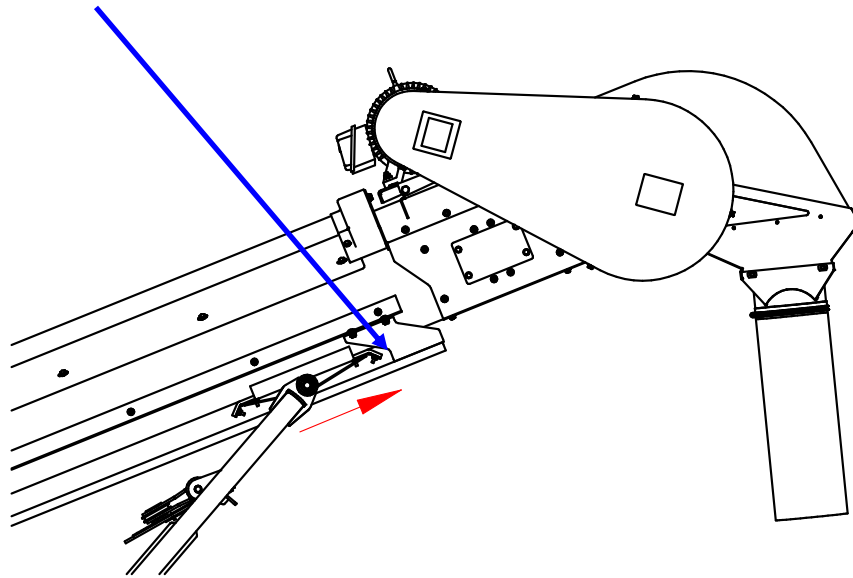

2. Once the cable is slack, remove cable clamps and cable from anchor.

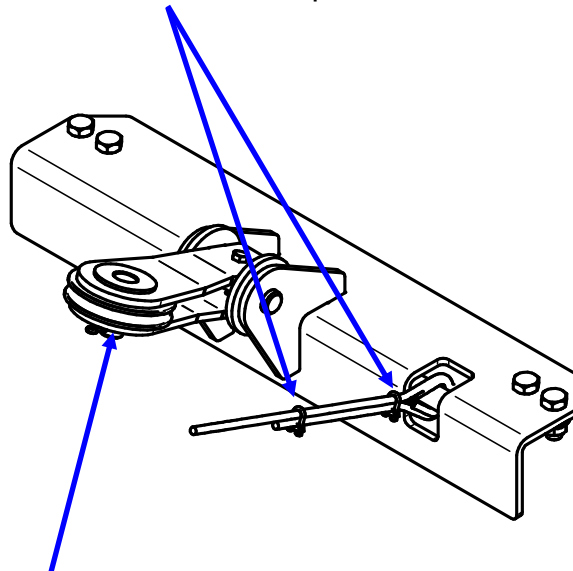

3. Remove cotter pin, pulley pin and the pulley from the upper cross member. Set aside for re-installation later.

ELECTRIC WINCH AND CABLE KIT INSTALLATION (20 - 35 FT CONVEYORS)

4. Remove and discard the four mounting bolts, winch and winch cable

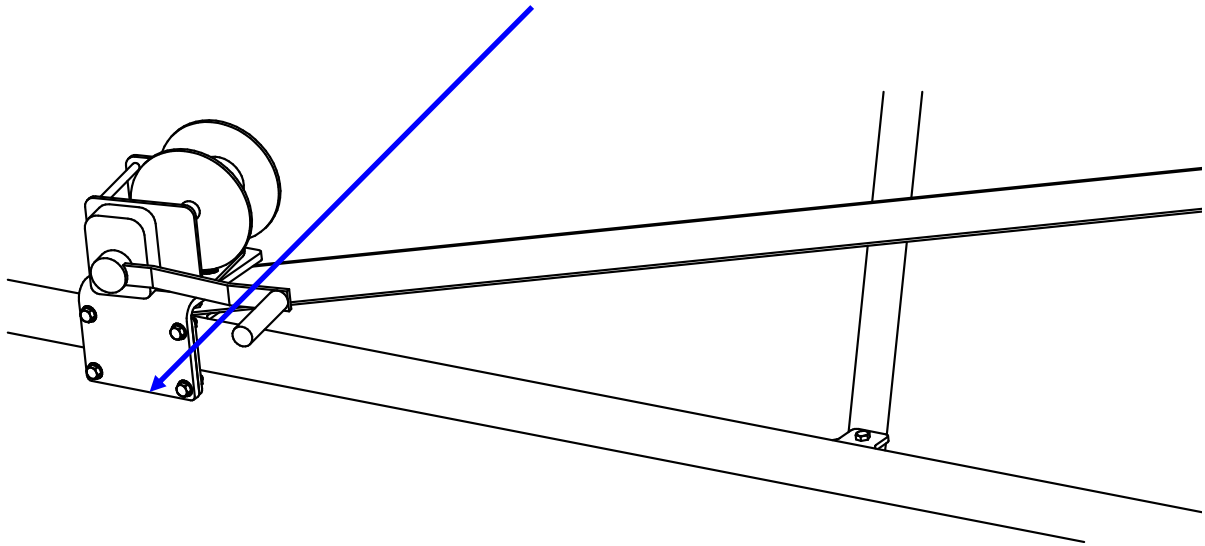

5. Remove the limit switch assembly and set aside. Loosen the six 3/8 bolts and slide the mounting plates out to the end of the adjustment slots.

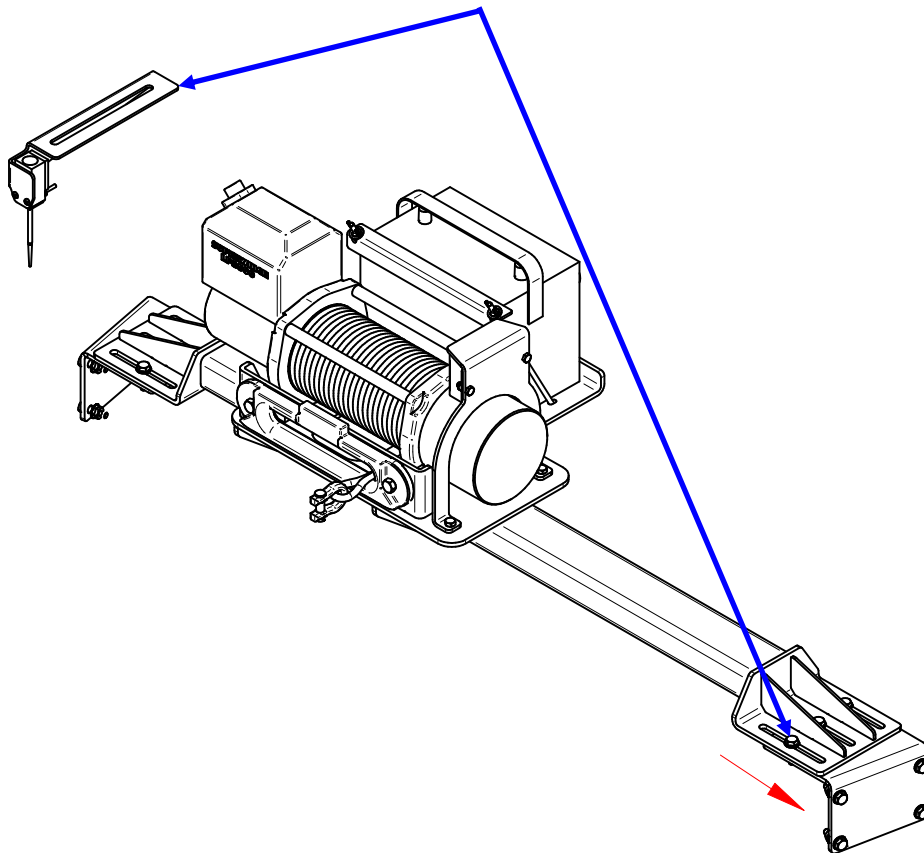

ELECTRIC WINCH AND CABLE KIT INSTALLATION (20 - 35 FT CONVEYORS)

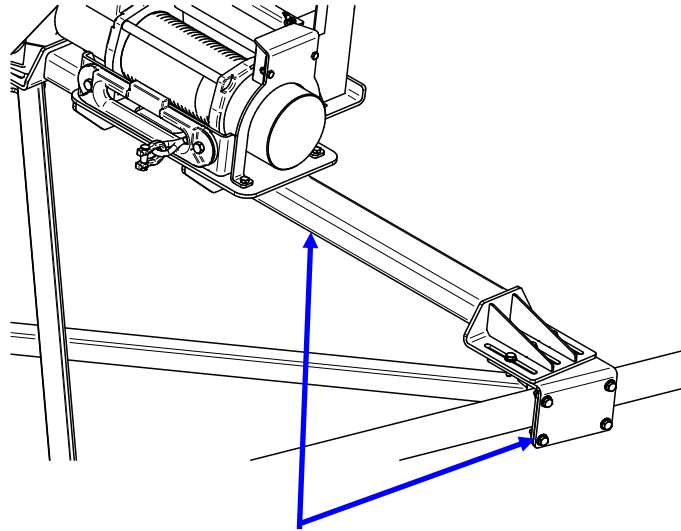

6. Place the winch assembly over the trailing arms. Slide the mounting plates into place and install mounting hardware. Do not fully tighten the hardware until both sides are positioned correctly.

7. After the winch assembly is positioned correctly, tighten all mounting hardware.

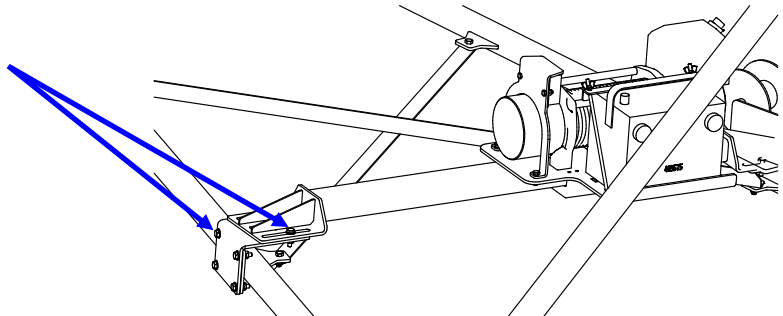

8. Remove the lever stop bracket from the winch assembly. This allows access to the clutch release lever on the winch. Rotate the lever to allow the spool to free wheel. Pull the cable out of the winch for routing through the pulleys.

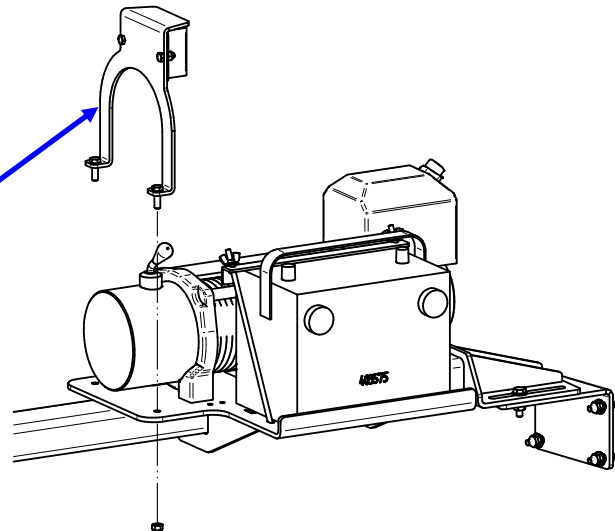

ELECTRIC WINCH AND CABLE KIT INSTALLATION (20 - 35 FT CONVEYORS)

9. Route the cable as shown on the view below in red. At each pulley, the cotter pin, clevis pin, washer and pulley must be removed. After placing the cable into the pully bracket, re-install pulley and hardware capturing the cable. Run the cable from the winch through the bottom pivoting pulley, through the top pulley, back down through the bottom non-pivoting pulley.

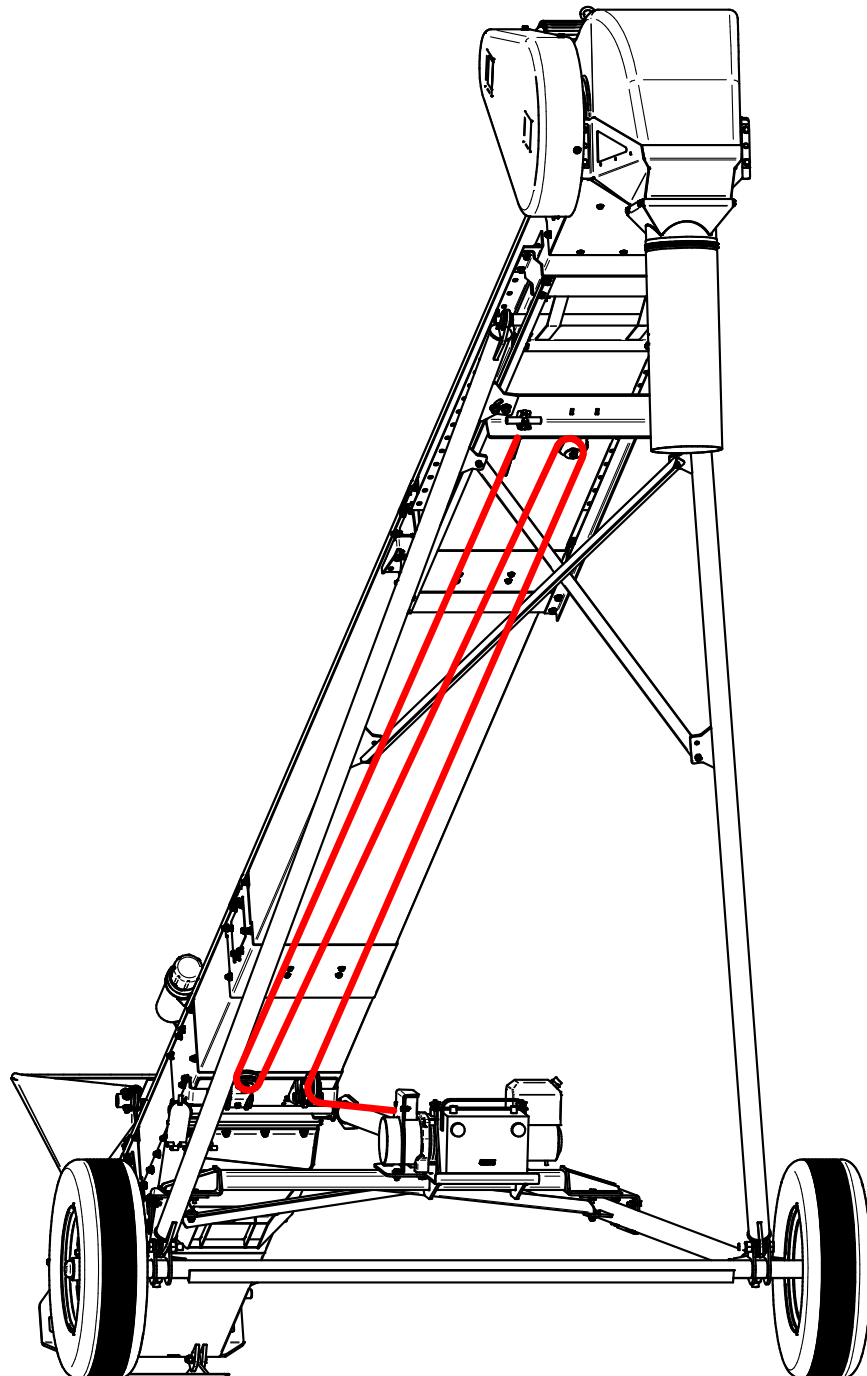

ELECTRIC WINCH AND CABLE KIT INSTALLATION (20 - 35 FT CONVEYORS)

10. Once the cable has been routed, use the shackle and cotter pin to attach the cable end to the anchor plate.

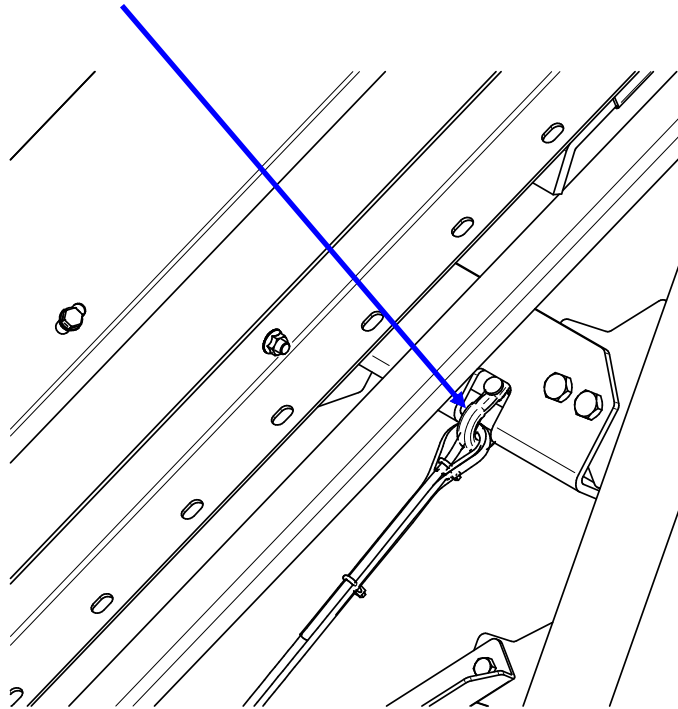

11. Rotate clutch release lever back into operating position. Re-install the lever stop bracket and tighten hardware.

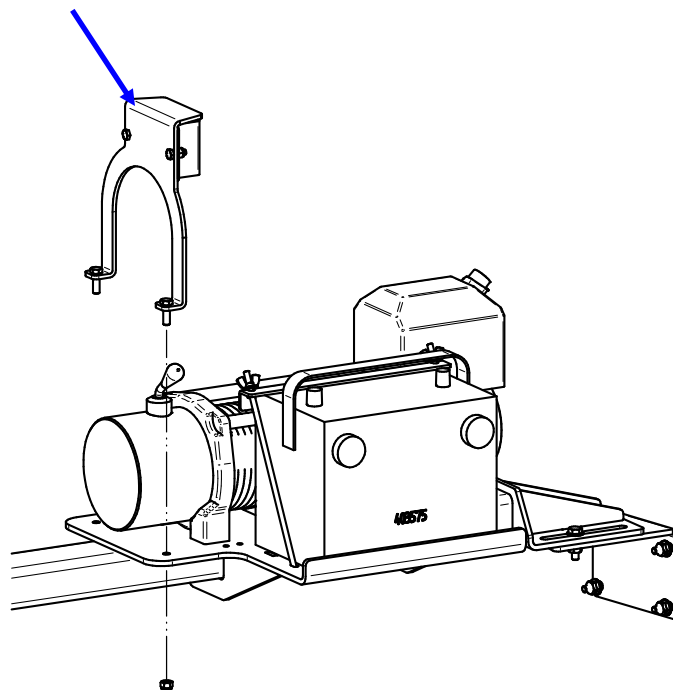

ELECTRIC WINCH AND CABLE KIT INSTALLATION (20 - 35 FT CONVEYORS)



THE CONVEYOR SHOULD NEVER BE OPERATED WITHOUT THE LEVER STOP BRACKET AND COVER IN PLACE.

12. Install the limit switch bracket and limit switch previously removed from the winch assembly. The bracket will mount using the existing hardware for the lower stop bracket.

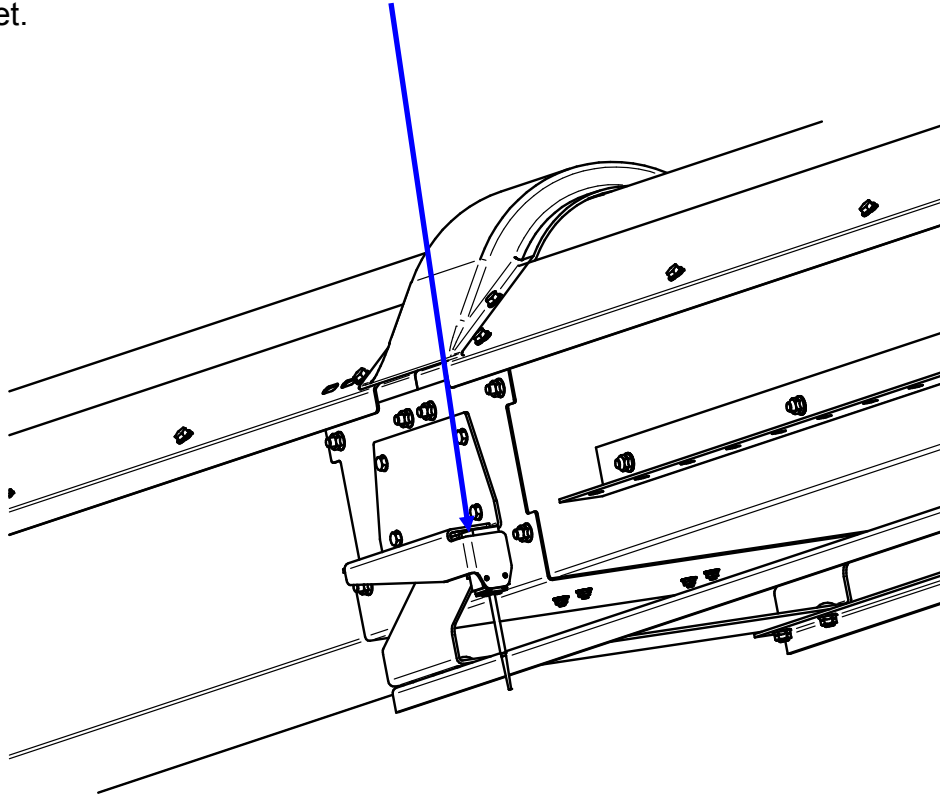

ELECTRIC WINCH AND CABLE KIT INSTALLATION (20 - 35 FT CONVEYORS)

13. Route wiring for limit switch as shown below. Use the wire clamps provided in the kit to attach the cable as needed. Install pendant control to winch and make sure the battery connections are secure. Operate the winch to verify it is operating correctly. When lowering the conveyor, cease operation of the winch once the slide assembly makes contact with the upper stop to prevent the cable from unspooling.

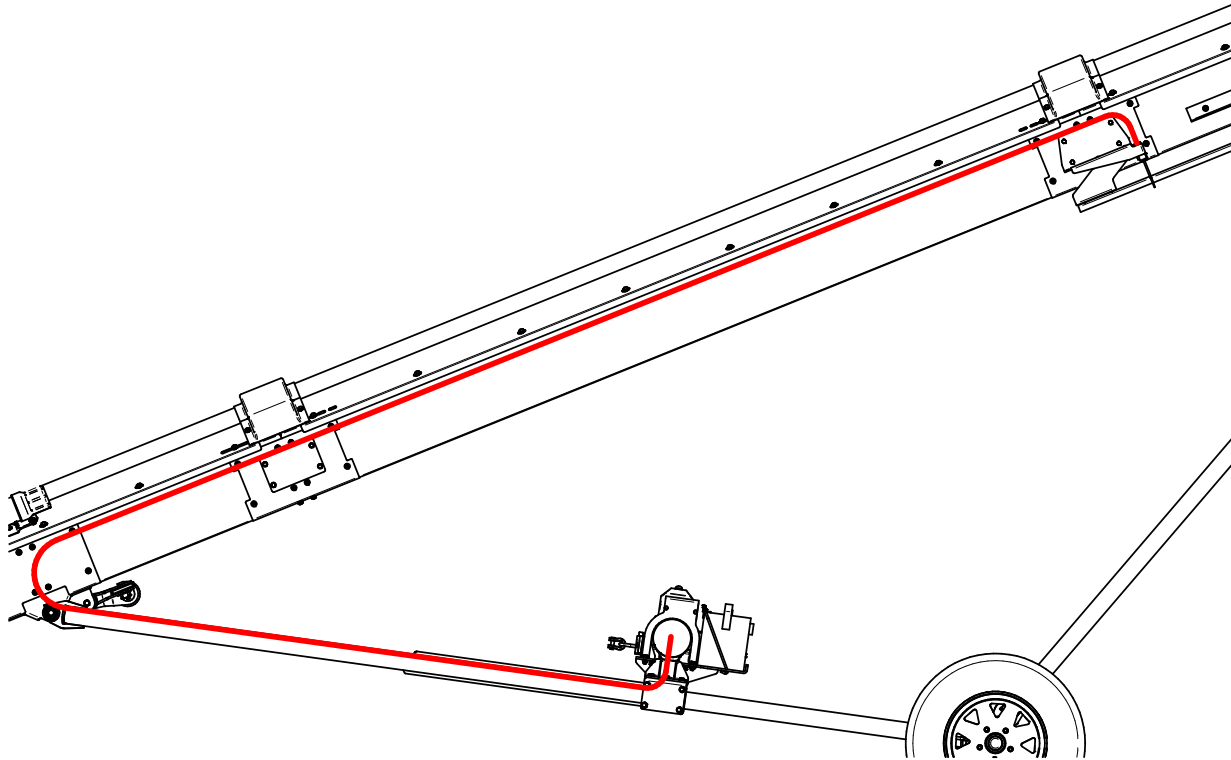

⚠ CAUTION

THE LIMIT SWITCH MUST BE ADJUSTED CORRECTLY TO PREVENT DAMAGE TO THE UNIT WHEN FULLY RAISED. ADJUST LIMIT SWITCH SO THAT WINCH WILL NO LONGER RAISE ONCE SLIDE CONTACTS STOP.

UNDERCARRIAGE ASSEMBLY 40 AND 45 FT CONVEYORS

The following instructions should be used to assemble your USC conveyor undercarriage. Hand tighten all fasteners until undercarriage is completely assembled.

NOTICE

The undercarriage for each length of conveyor (40 Foot and 45 Foot), has a unique assembly number and assembly part numbers.

1. Lay the Axle flat on the ground **(A)**.
2. Mount both tires **(B)**.
3. Assemble the upper arm weldments to the axle **(C)**.
4. Assemble the upper pully cross member to both arms. Make sure the cross member is positioned with the pulley facing the axle and the pulley on top **(D)**.
5. Assemble the upper cross braces **(E)**.
6. Using the upper arm pin, assemble the Transport Slide. Secure the arm pin with two cotter pins on either end **(F)**.
7. Assemble the lower arm weldment with the winch mounting bracket to the axle **(G)**.
8. Assemble the other lower arm weldment to the axle **(H)**.
9. Assemble the lower pully cross member to both arms. Make sure the cross member is positioned with the pulley on top **(J)**.
10. Assemble the lower cross braces **(K)**.
11. Assemble the cable anchor cross member **(L)**.
12. Tighten all of the fasteners.

UNDERCARRIAGE ASSEMBLY 40 AND 45 FT CONVEYORS

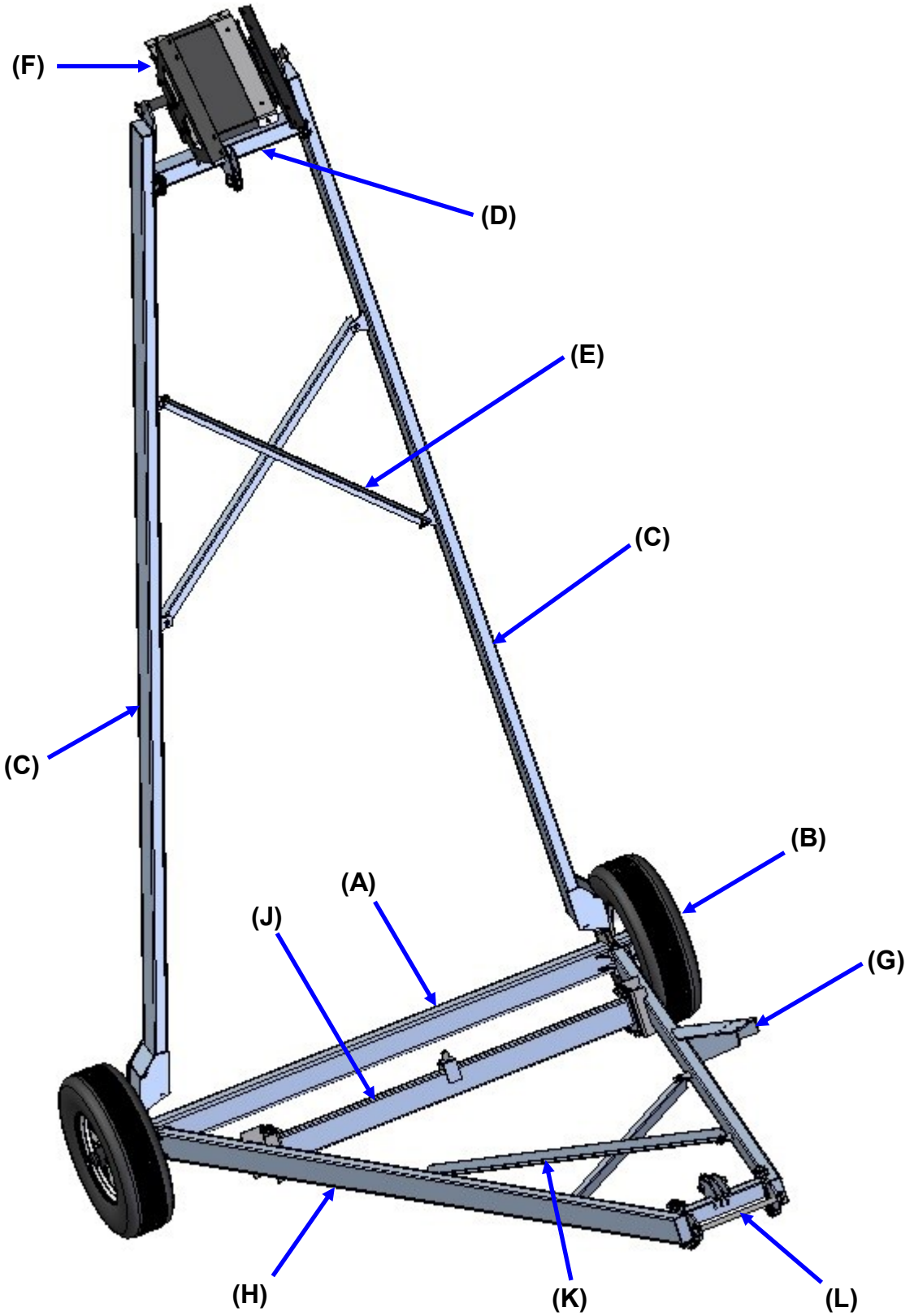

UNDERCARRIAGE AND BASE CONVEYOR ASSEMBLY 40 - 45 FT CONVEYOR

1. Using a forklift, pick up the base conveyor assembly in the center. Move conveyor the over the assembled undercarriage centering it.
2. Mount the upper stop mounts using the holes designated in detail **A** (see pages 42 and 44).
3. Mount the lower stop mounts using the holes designated in detail **B** (see pages 42 and 44).
4. Lift the undercarriage slide until it is pressed firmly against the under side of the conveyor between the lower stop mount.
5. Install the support cables from the lower stop bracket to the upper stop bracket. To prevent damage, do not overtighten the cables.
6. Raise the lower arms until the undercarriage bracket lines up with the holes on the splice mounting bracket. Insert the lower arm pin. Secure each end of the pin with a cotter pin.

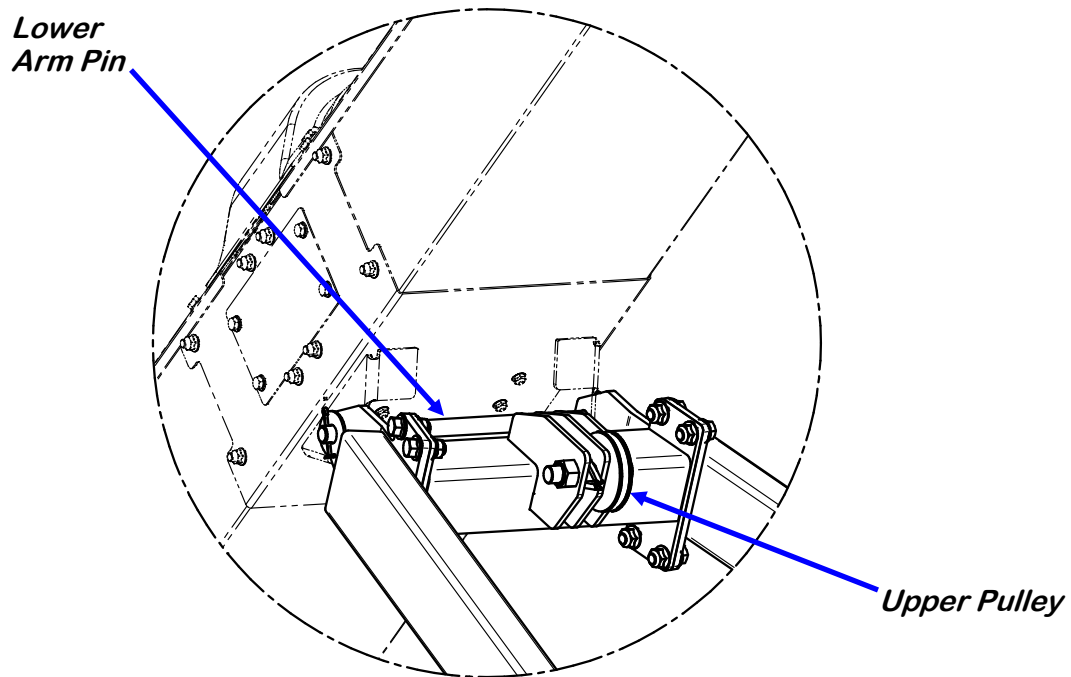

DETAIL C

UNDERCARRIAGE AND BASE CONVEYOR ASSEMBLY 40 FT CONVEYOR

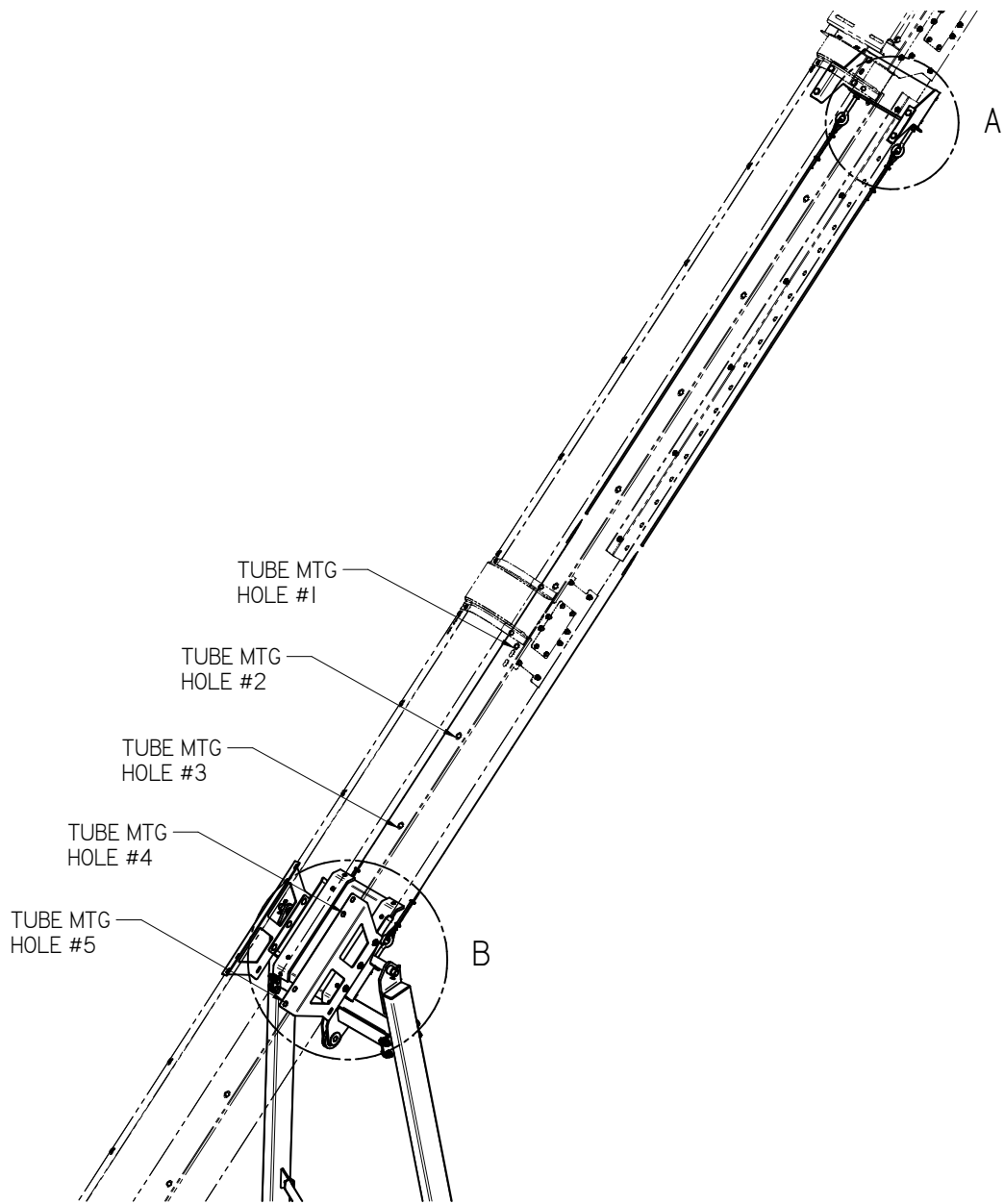

USC CONVEYORS

SLIDE MOUNT DETAILS 40 FT CONVEYOR

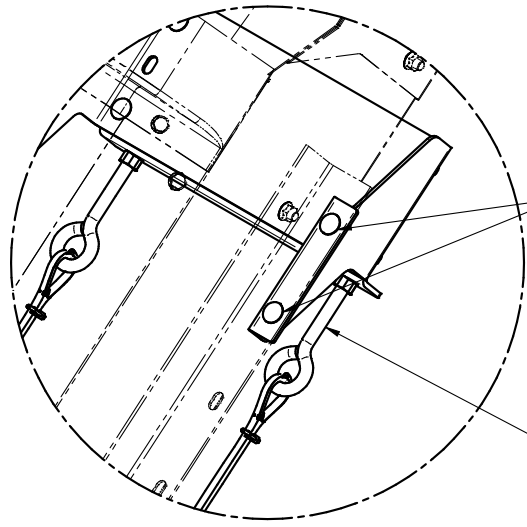

UPPER STOP MOUNTS IN
1ST & 2ND HOLES OF ANGLE
MOUNTS

TO PREVENT DAMAGE,
DO NOT OVERTIGHTEN
CABLES WHEN INSTALLING

DETAIL A

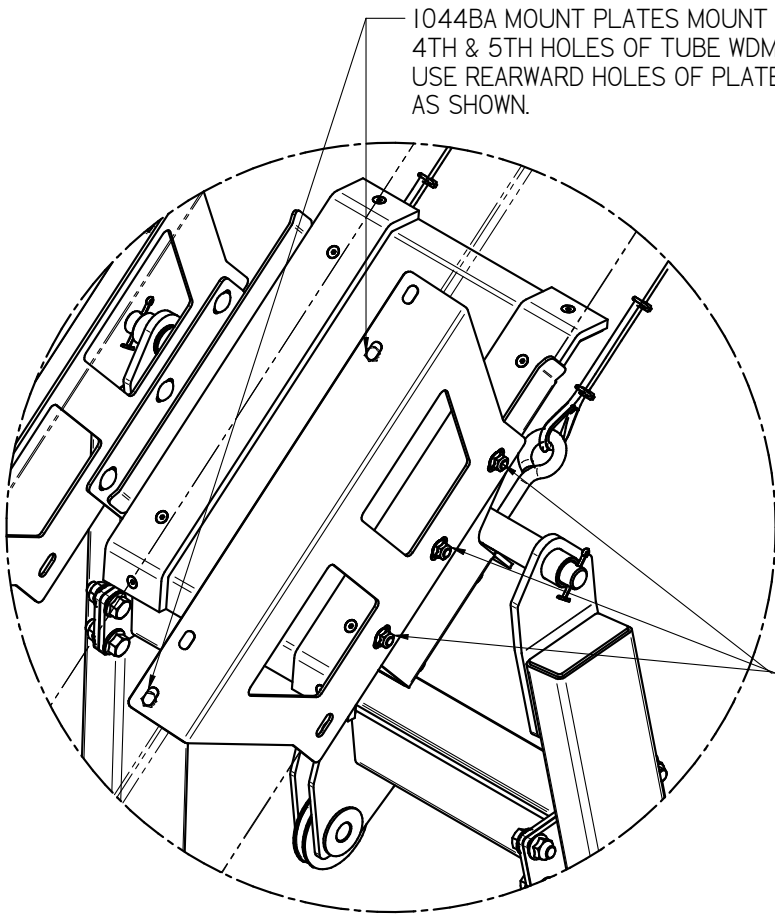

1044BA MOUNT PLATES MOUNT IN
4TH & 5TH HOLES OF TUBE WDMT.
USE REARWARD HOLES OF PLATE
AS SHOWN.

USE LOWER STOP MOUNTS
IN FORWARD 3 HOLES OF
1044BE MOUNT PLATE AS
SHOWN.

DETAIL B

UNDERCARRIAGE AND BASE CONVEYOR ASSEMBLY 45 FT CONVEYOR

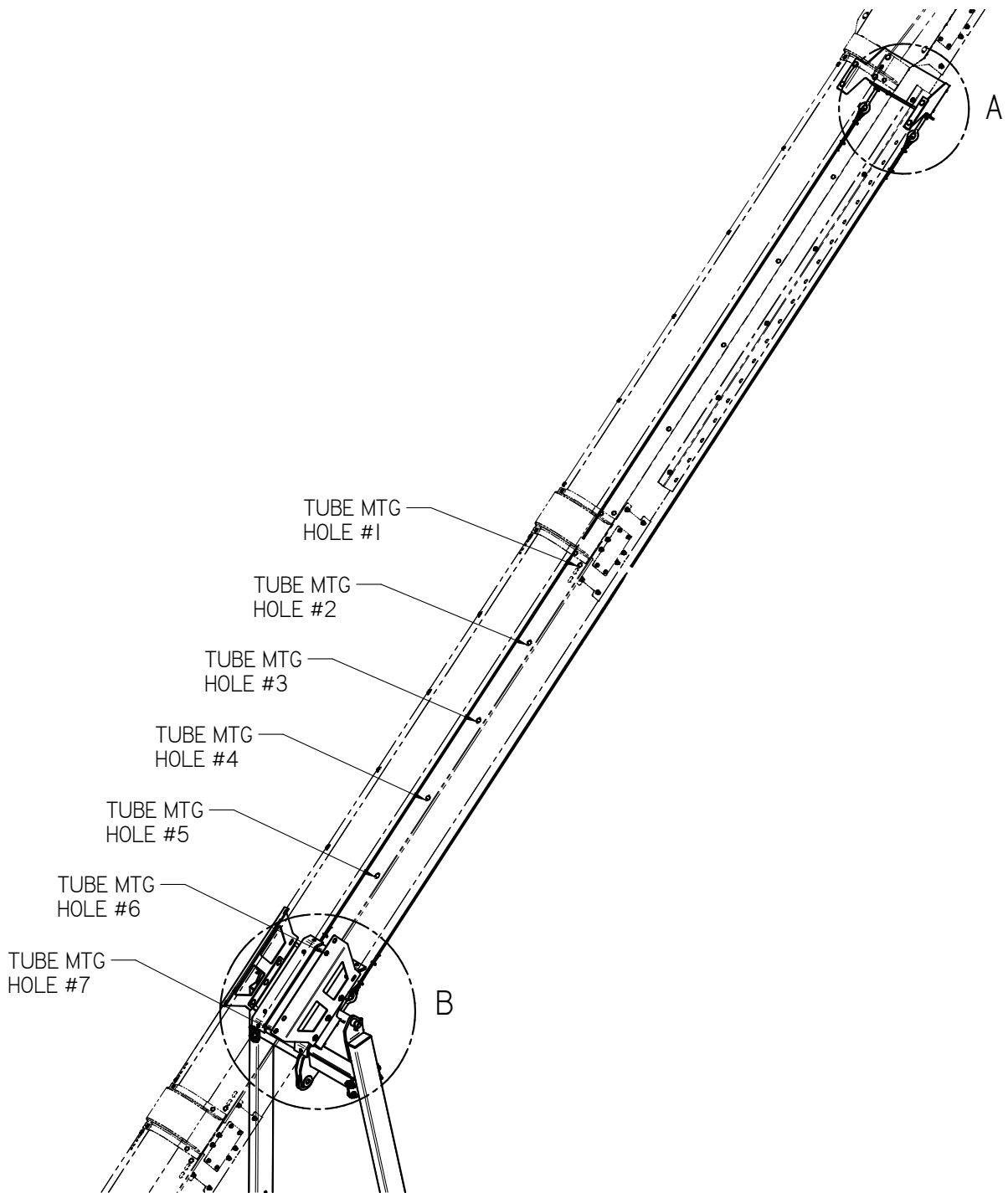

SLIDE MOUNT DETAILS 45 FT CONVEYOR

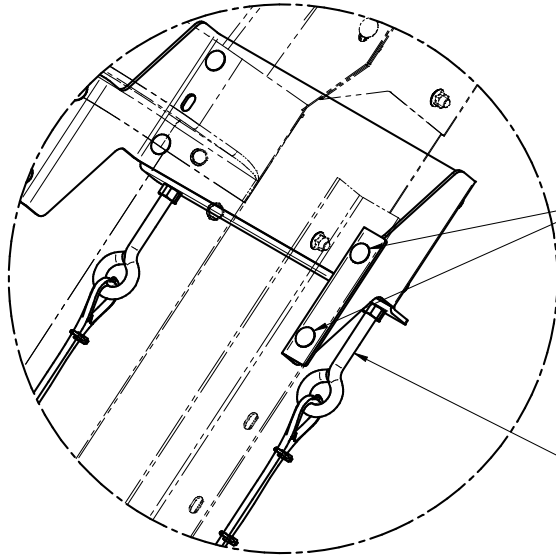

UPPER STOP MOUNTS IN
1ST & 2ND HOLES OF ANGLE
MOUNTS AS SHOWN.

TO PREVENT DAMAGE,
DO NOT OVERTIGHTEN
CABLES WHEN INSTALLING

DETAIL A

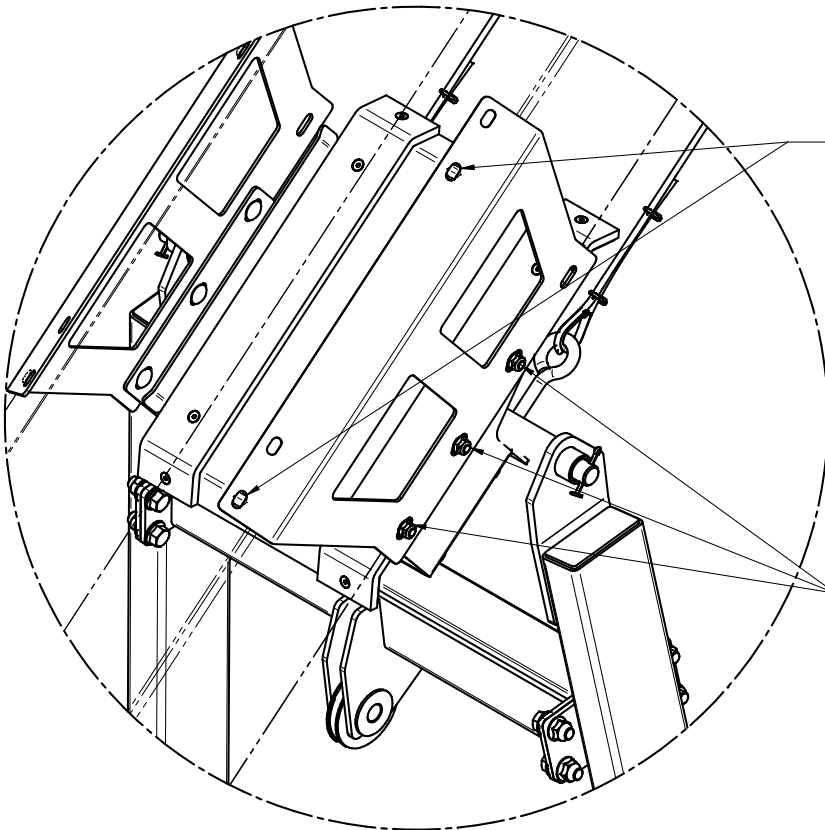

1044BA MOUNT PLATES MOUNT IN
6TH & 7TH HOLES OF TUBE WDMT.
USE REARWARD HOLES OF PLATE
AS SHOWN.

USE LOWER STOP MOUNTS
FORWARD 3 HOLES OF
1044BE MOUNT PLATE AS
SHOWN.

DETAIL B

MANUAL WINCH AND CABLE INSTALLATION 40 - 45 FT CONVEYORS

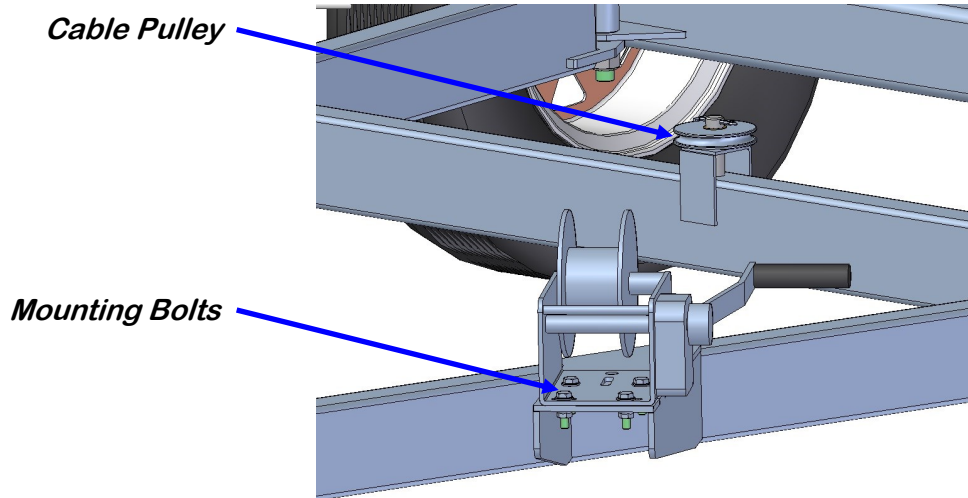

1. Slide the cable pulley (01-02-0074) onto the spindle in the middle of the cross member and secure it with a cotter pin (06-09-0023).
2. Assemble the winch to the bracket on the lower arm using the hardware provided. Adjust the winch so that the spindle directly faces the cross member pulley before tightening the four mounting bolts
3. Attach the cable to the crank.
4. Route the cable through the pulleys and attach to the under-carriage cable anchor following the path as shown in the illustration on page 46.
5. After cable has been run through the pulleys, terminate at the cable anchor on the upper cross member as shown below.

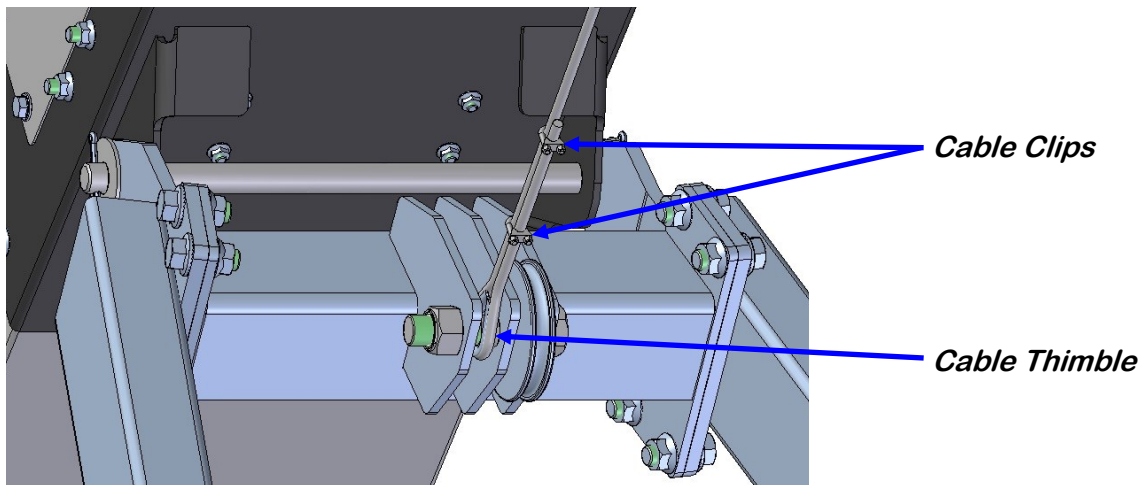

MANUAL WINCH CABLE ROUTING 40 - 45 FT CONVEYORS

6. Route the cable as shown on the view below in red. After the first pulley, each pulley, cotter pin, clevis pin, washer and pulley must be removed. After placing the cable into the pulley bracket, re-install pulley and hardware capturing the cable. Run the cable from the winch around the cross member pulley, through the pivoting pulley, through the top pulley, back down through the bottom non-pivoting pulley and terminate at the cable anchor.

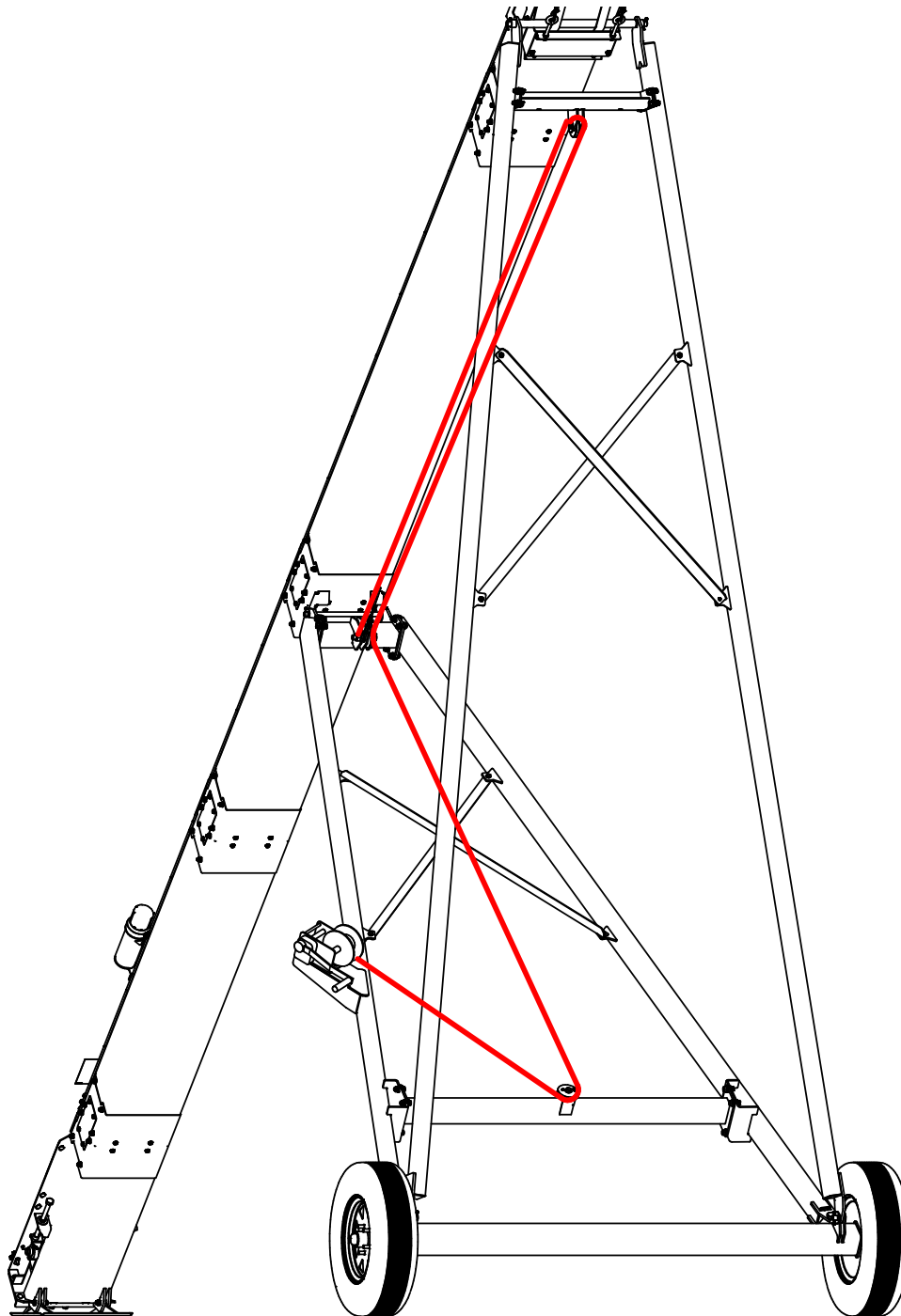

ELECTRIC WINCH AND CABLE KIT INSTALLATION (40 - 45 FT CONVEYORS)

NOTICE

If electric winch kit was ordered at the same time as the conveyor, steps 1 through 4 will not be necessary.

1. Lower conveyor until slide is against upper stop. When fully lowered winch cable should be slack.

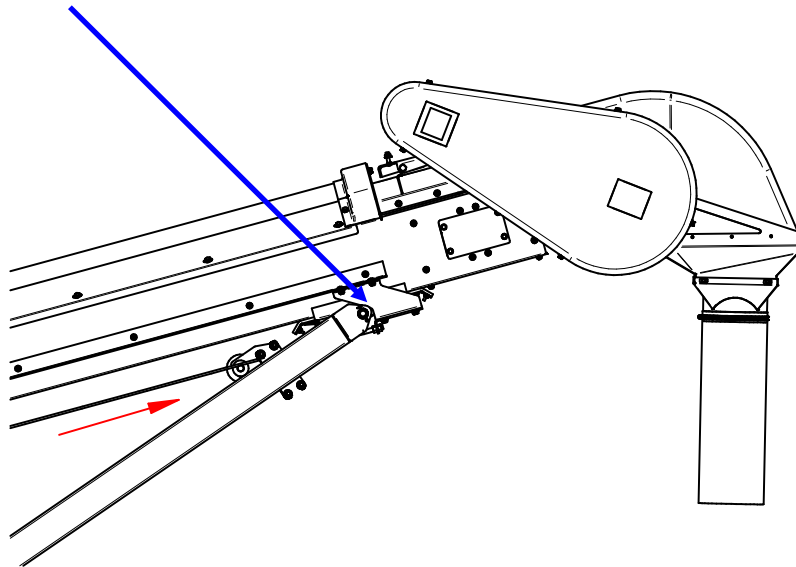

2. Once the cable is slack, remove cable clamps and cable from anchor.

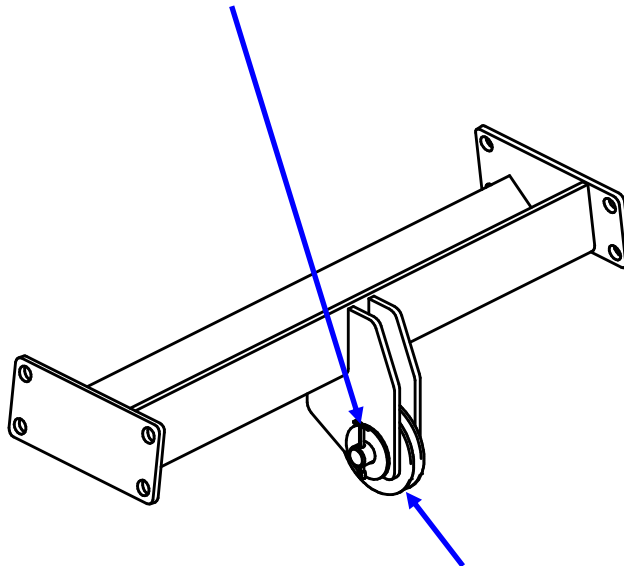

3. Remove cotter pin, pulley pin and the pulley from the upper cross member. Set pulley and pins aside for re-installation later.

4. Remove and discard the four mounting bolts, winch and winch cable. Remove and discard the cotter pin, washer and pulley.

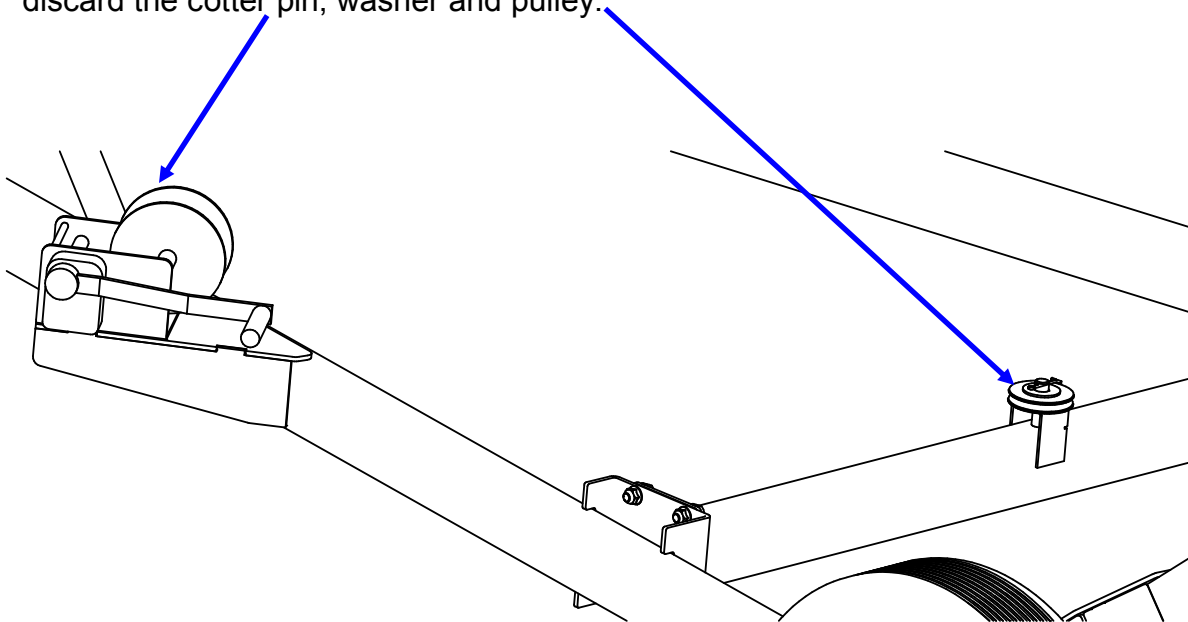

5. Remove the limit switch assembly and set aside. Remove the bottom two 1/2" nuts and bolts and set aside. Loosen the top two 1/2" fasteners far enough to allow the brackets to spread apart wide enough to slide over the undercarriage crossmember.

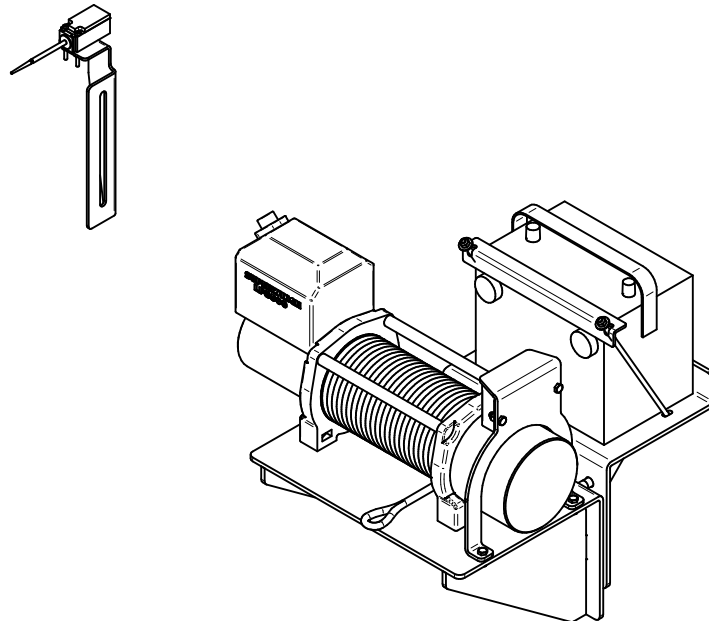

ELECTRIC WINCH AND CABLE KIT INSTALLATION (40 - 45 FT CONVEYORS)

6. Make sure the assembly is centered so the bracket cutouts clear the pulley mounting weldment. Insert the bottom fasteners. Do not fully tighten the hardware until both sides are positioned correctly, then tighten.

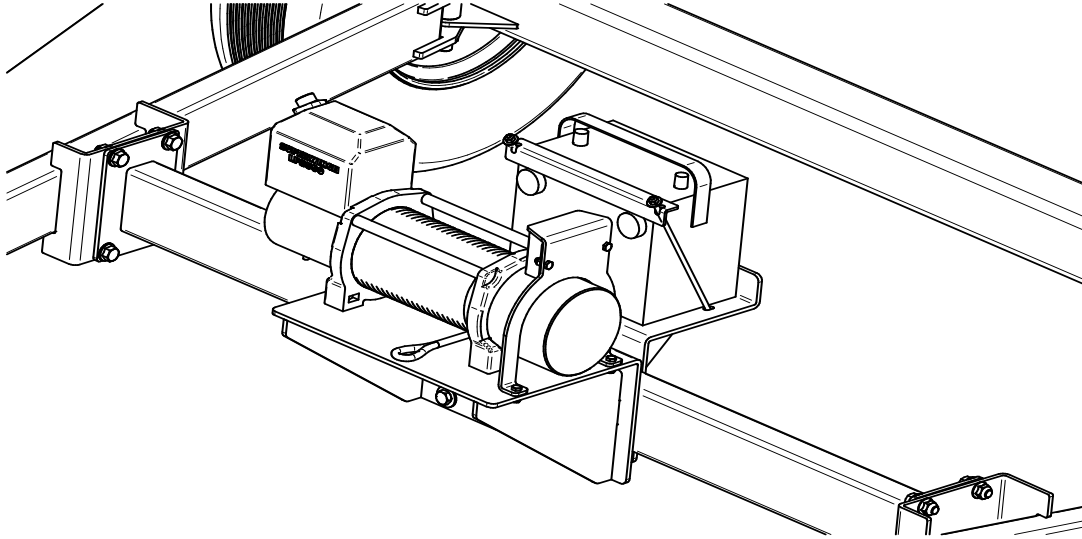

7. Remove the lever stop bracket from the winch assembly. This allows access to the clutch release lever on the winch. Rotate the lever to allow the spool to free wheel. Pull the cable out of the winch for routing through the pulleys.

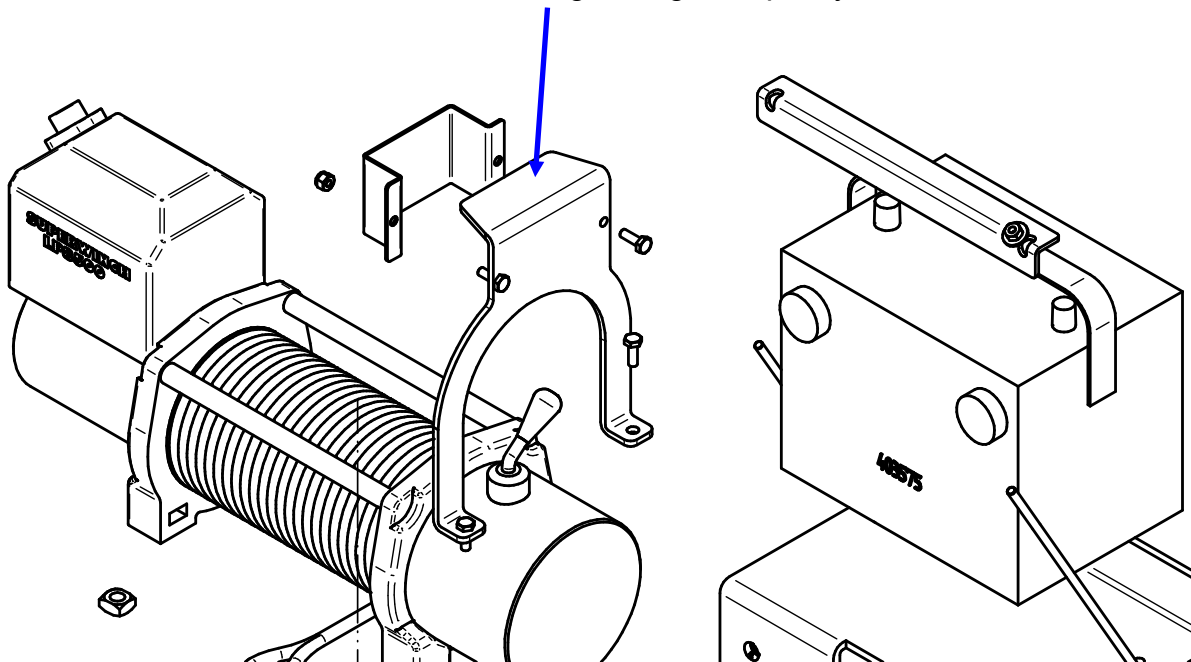

ELECTRIC WINCH AND CABLE KIT INSTALLATION (40 - 45 FT CONVEYORS)

8. Route the cable as shown on the view below in red. At each pulley, the cotter pin, clevis pin, and pulley must be removed. After placing the cable into the pulley bracket, re-install pulley and hardware capturing the cable. Run the cable from the winch through the bottom pulley, through the top pulley and back down to the anchor next to the bottom pulley.

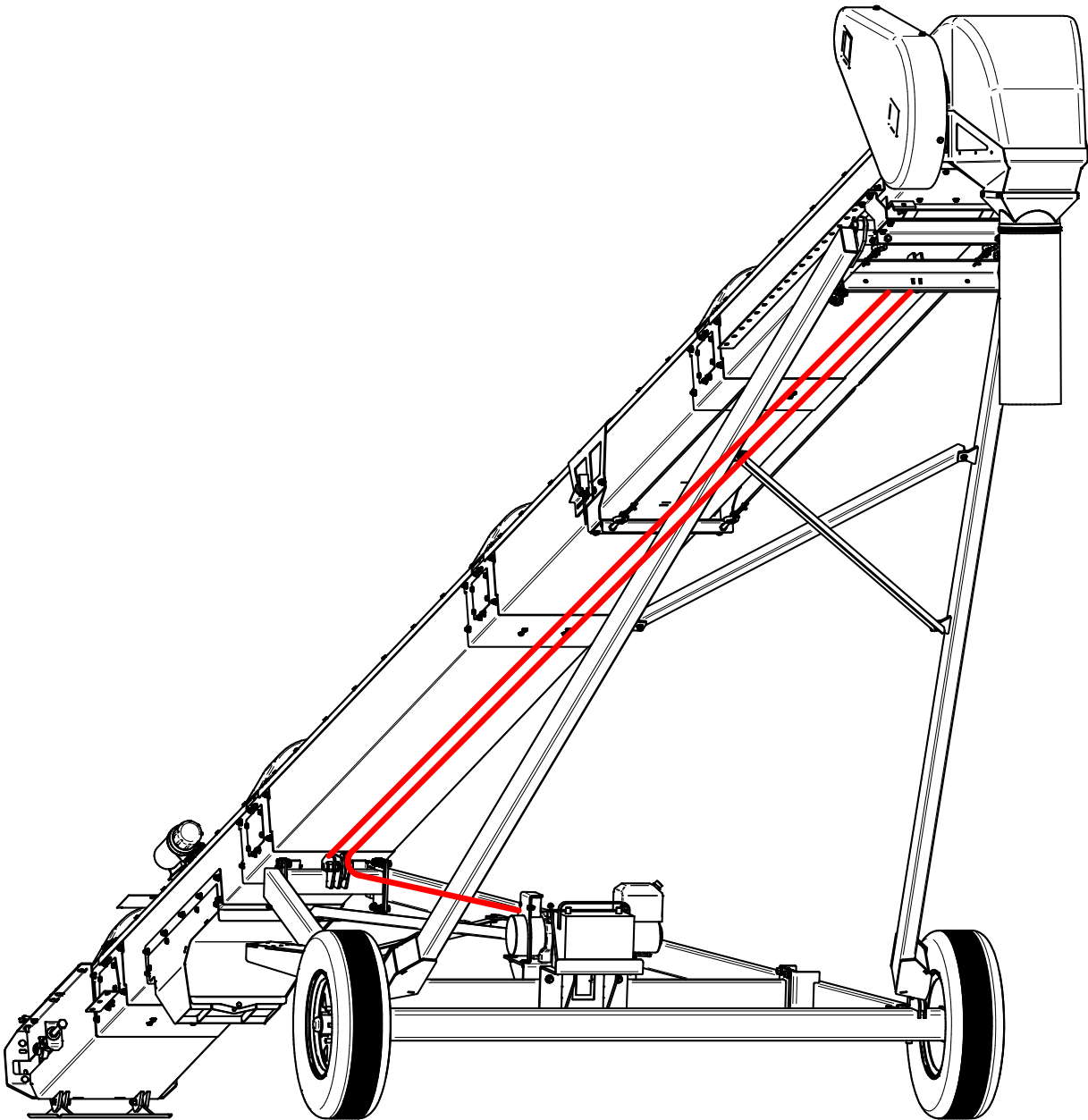

ELECTRIC WINCH AND CABLE KIT INSTALLATION (40 - 45 FT CONVEYORS)

9. Once the cable has been routed, use the shackle and cable clamps to attach the cable end to the anchor plate. Retain bottom pulley and cable anchor with nut and tighten as needed.

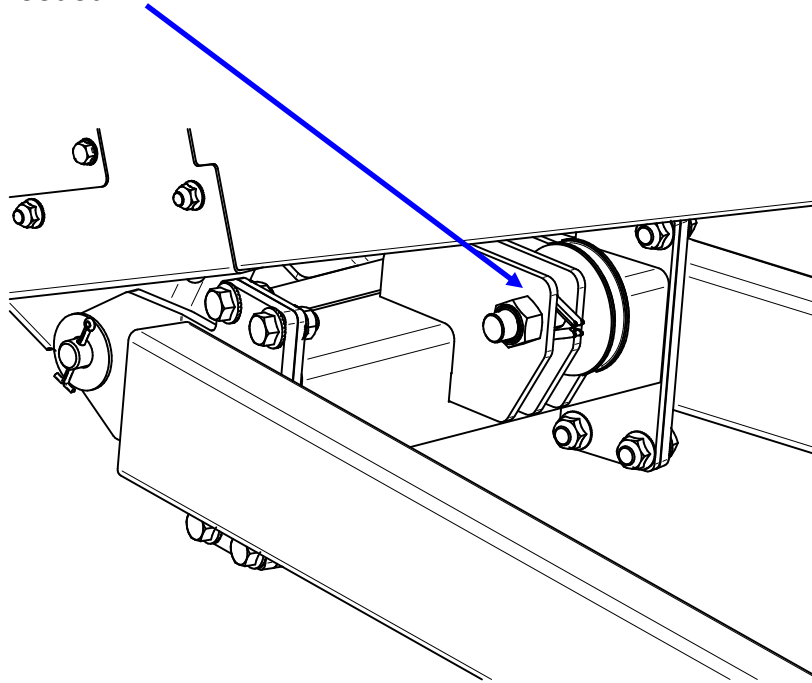

10. Rotate clutch release lever back into operating position. Re-install the lever stop bracket and tighten hardware.

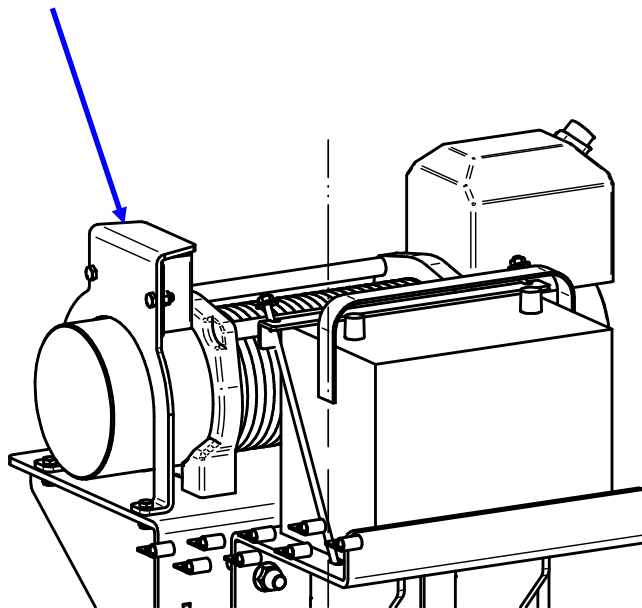

ELECTRIC WINCH AND CABLE KIT INSTALLATION (40 - 45 FT CONVEYORS)

CAUTION THE CONVEYOR SHOULD NEVER BE OPERATED WITHOUT THE LEVER STOP BRACKET AND COVER IN PLACE.

11. Install the limit switch bracket and limit switch previously removed from the winch assembly. The bracket will mount using the existing hardware for the lower stop bracket. The bracket is slotted to allow for switch adjustment.

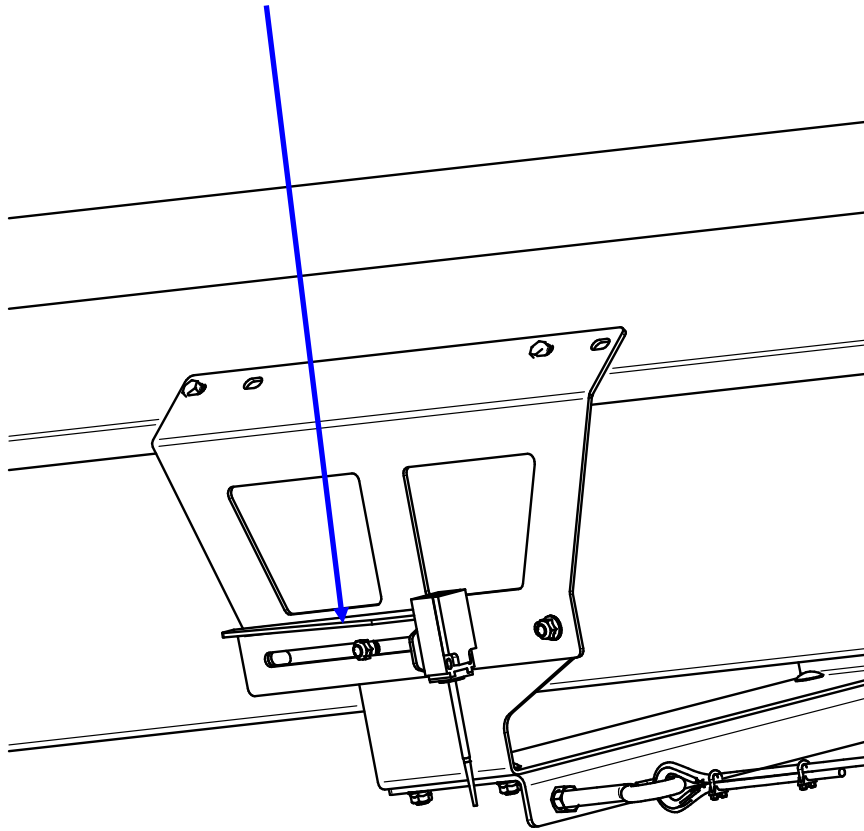

ELECTRIC WINCH AND CABLE KIT INSTALLATION (40 - 45 FT CONVEYORS)

12. Route wiring for limit switch as shown below. Use the wire clamps provided in the kit to attach the cable as needed. Install pendant control to winch and make sure the battery connections are secure. Operate the winch to verify it is operating correctly. When lowering the conveyor, cease operation of the winch once the slide assembly makes contact with the upper stop to prevent the cable from unspooling.

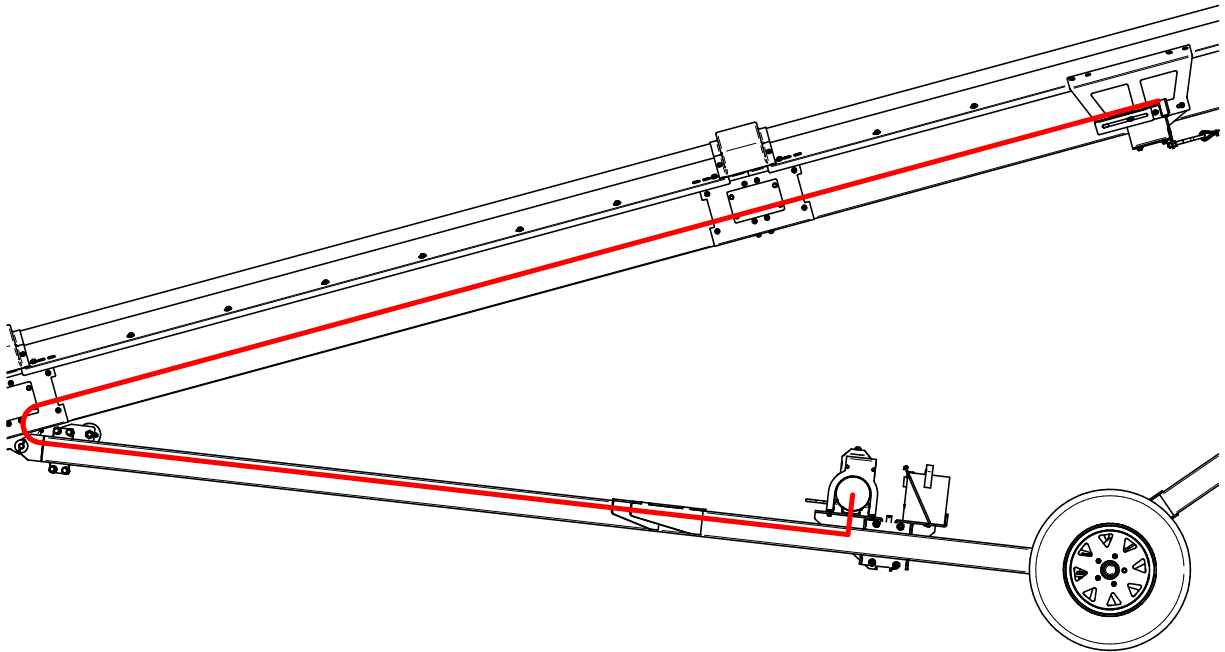

THE LIMIT SWITCH MUST BE ADJUSTED CORRECTLY TO PREVENT DAMAGE TO THE UNIT WHEN FULLY RAISED. ADJUST LIMIT SWITCH SO THAT WINCH WILL NO LONGER RAISE ONCE SLIDE CONTACTS STOP.

Have a licensed electrician provide power to the machine per the National Electrical Code ANSI/NFPA 70 and local codes. For customer safety and ease of use, a motor disconnect switch may be mounted on the conveyor depending on options ordered.

*Conveyors supplied with cord kits and/or used with USC control packages can be directly wired or plugged into the USC control panels for controlling on/off and supplying motor overload protection. **If conveyor is not controlled by a USC control panel, end-user will be responsible for ensuring that motor thermal overload protection is provided.***

S-1 CONVEYOR STAND (0—56 INCHES)

ASSEMBLY PROCEDURE

1. Verify that all parts came with the stand.
2. Adjust the width of the cradle (item 2) to fit the conveyor body.
3. Slip one each of the mounting plates (item 3) on the tubes at the base of the stand (item 1).
4. Raise up the head section of the conveyor and support at the desired height.
5. Place the cradle in the desired location near the head of the conveyor.
6. If the cradle is able to be attached to the rail on the sides of the conveyor, bolt it in place with the bolts provided in the head parts bag.
7. If step 6 is not possible, attach the two side plates and secure with ALL ten self-tapping screws provided in the head parts bag.
8. Anchor the stand to the floor using the concrete anchors (item 5).

Item #	Part #	Description
1	05-03-0850	WDMT 15FT S2000 CART SUPP
2	05-05-0178	CRADLE
3	05-10-3628	BRKT SUPP MNT CNVR TAIL TALL
4	06-01-0029	BOLT .500-13 X 3.25 ZP GR5
5	06-01-0220	BOLT 3/8-16 CONC ANCHOR ZP 3.75
6	06-03-0004	NUT NYL LOCK .500-13 ZP GR5

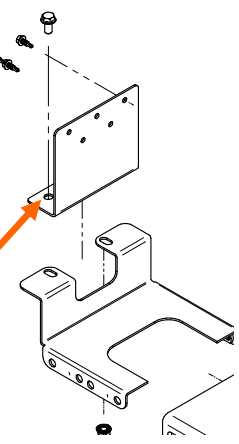
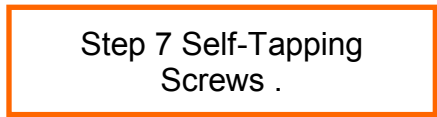
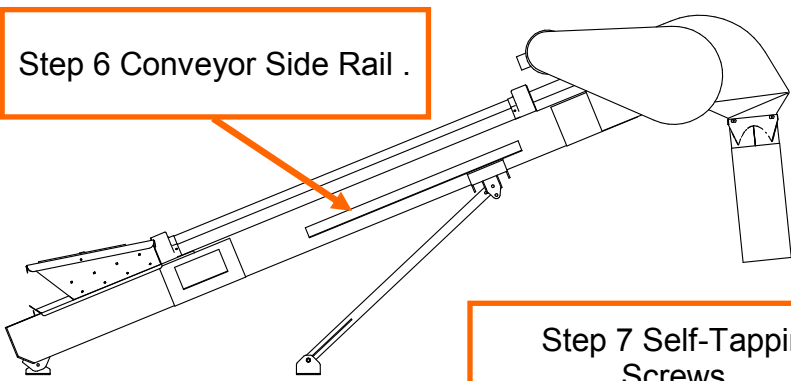
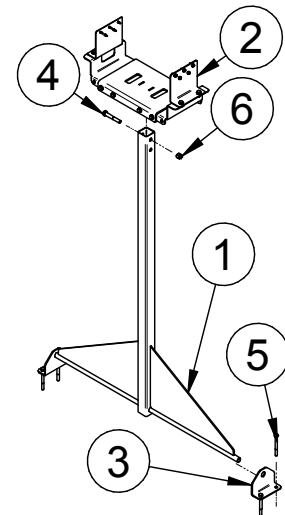

USC CONVEYORS

S-2 — S-5 CONVEYOR STANDS

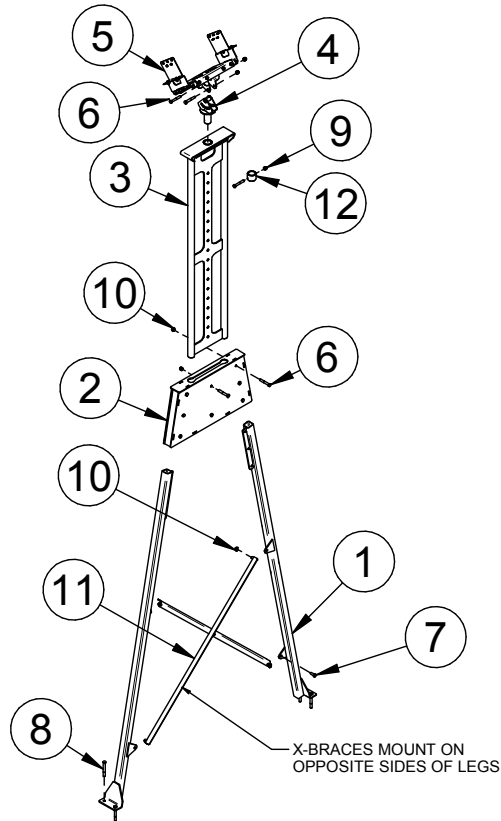

Item	Part #	Description
1	VARIES	LEG
2	05-03-1832	MOUNT WELDMENT
3	05-03-1834	WDMT SLIDE STAND MID
4	05-03-1841	WDMT STAND PIVOT
5	05-05-0178	CRADLE
6	06-01-0029	BOLT .500-13 X 3.25 ZP GR5
7	06-01-0080	BOLT .500-13 X 1.25 ZP GR5
8	06-01-0086	BOLT .500-13 CONC ANCHOR ZP 4.25
9	06-03-0004	NUT NYL LOCK .500-13 ZP GR5
10	06-03-0015	NUT LOCK FLG .500-13 ZP GR5
11	VARIES	ANGLE CROSS BRACE
12	106582	BUSHING RETAINER



WARNING If the conveyor is going to be over an electrical panel (e.g. Treater Control Panel), the stand must be a minimum of 4 feet from the panel. Per Code.

S-2 — S-5 CONVEYOR STANDS

ASSEMBLY PROCEDURE

1. Verify that all parts came with the stand.
2. Adjust width of the cradle (item 5) to fit the conveyor body.
3. Insert 2 of the legs (item 1) into the mount weldment (item 2) and secure with bolts.
4. If applicable, attach items cross supports (items 10 & 11) to the legs with items with bolts. Note: the slide must fit between the cross braces.
5. Insert the slide (item 3) into the assembled base.
6. Raise up the head section of the conveyor and support at the desired height.
7. Move the stand to it's desired location under the conveyor.
8. If the cradle can be secured to the rail near the head of the conveyor, secure it with the bolts provided in the parts bag.
9. If step 8 is not possible, attach the two side plates and secure with ALL ten self-tapping screws.
10. Set the height of the stand by having the cradle attached to the conveyor and the bottom of the stand legs resting on the floor. The stand must be perpendicular to the floor. Then insert two bolts through the stand base (items 2), securing the slide and tighten the nuts on the bolts.
11. Secure the base of the stand to the floor with the concrete anchors (item 8).

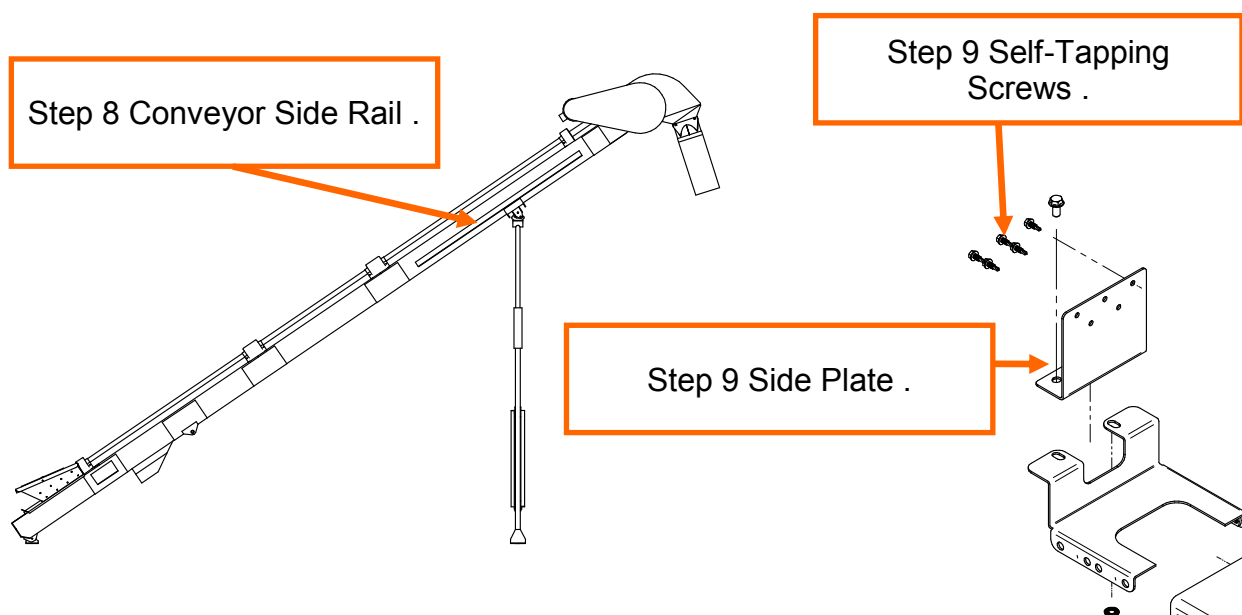

SECTION C **MECHANICAL OPERATION**

OPERATING SAFETY

<ol style="list-style-type: none"> 1. Read and understand the Operator's Manual and all safety signs before using. 2. Electric motor drives: Disconnect and disable electrical supply completely and wait for all moving parts to stop before servicing, adjusting, repairing or unplugging. 3. Clear the area of bystanders, especially children, before starting. 4. Be familiar with machine hazard area. If anyone enters hazard areas, shut down machine immediately. Clear the area before restarting. 5. Keep hands, feet, hair and clothing away from all moving and/or rotating parts. 6. Do not allow riders on the Conveyor or transport vehicle when transporting. 	<ol style="list-style-type: none"> 7. Stay away from overhead obstructions and power lines during operation and transporting. Electro-cution can occur without direct contact. 8. Do not operate machine when any guards are removed. 9. Lower Conveyor to its lowest position before moving or transporting or when not in use. 10. Inspect lift cable before using Conveyor. Replace if frayed or damaged. 11. Make certain lift cable is properly seated in cable pulleys. 12. Be sure that conveyor is empty before raising or lowering.
--	--

The USC conveyor is designed to efficiently move seed between a storage facility or seed totes and a truck, trailer or seed treater. Power is provided by an electric motor. Be familiar with the machine before starting.

It is the responsibility of the owner or operator to read this manual and to train all other operators before they start working with the machine. In addition to the design and configuration of equipment, hazard control and accident prevention are dependent upon the awareness, concern, and prudence of personnel involved in the operation, transport, maintenance and storage of equipment or in the use and maintenance of facilities.

NOTICE Follow all safety instructions exactly. Safety is everyone's business. By following recommended procedures, a safe working environment is provided for the operator, bystanders and the area around the worksite. Untrained operators are not qualified to operate the machine.

Many features incorporated into this machine are the result of suggestions made by customers like you. Read this manual carefully to learn how to operate the machine safely and how to set it to provide maximum efficiency. By following the operating instructions in conjunction with a good maintenance program, your conveyor will provide many years of trouble free service.

USC CONVEYORS
SYSTEM OVERVIEW

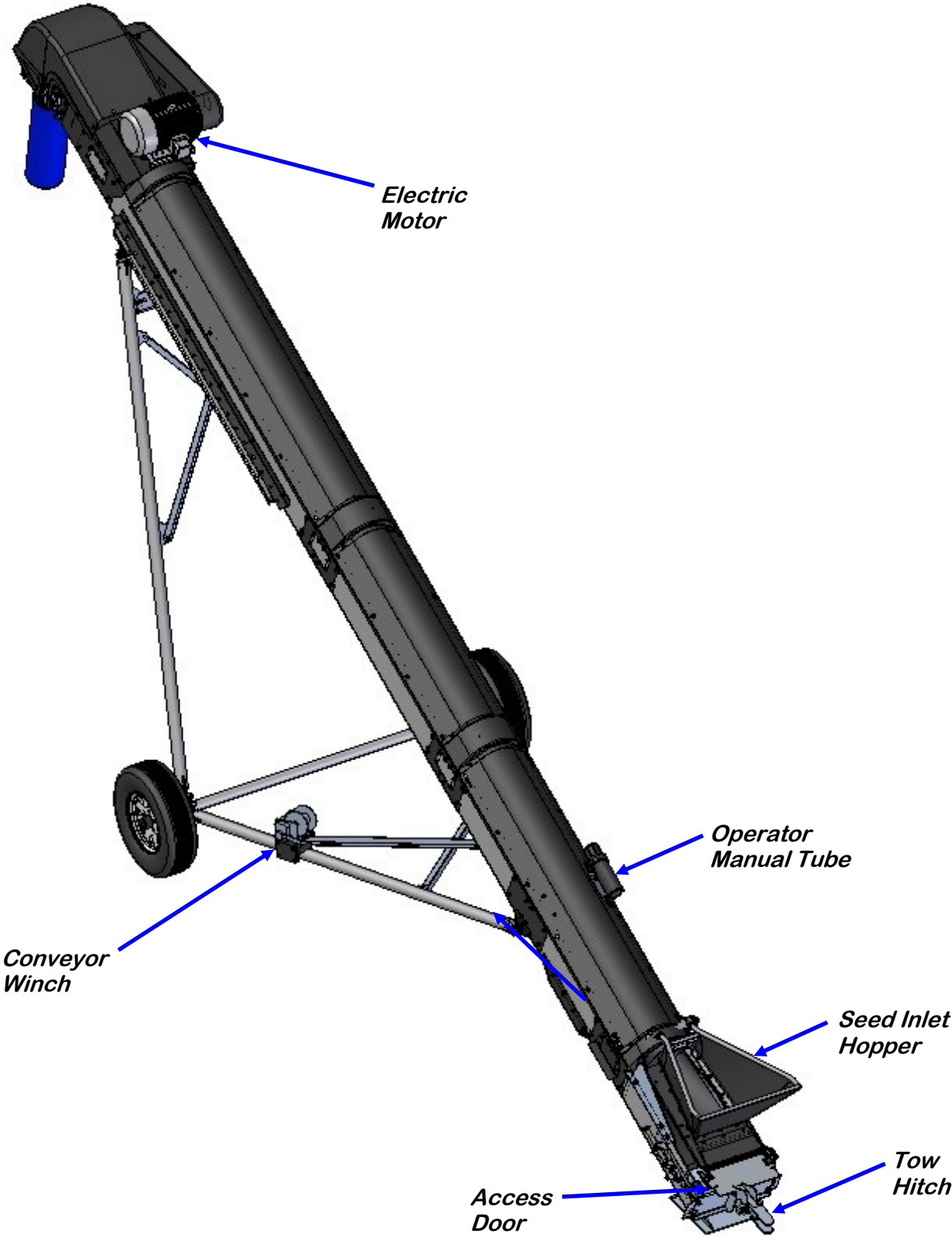

USC CONVEYORS

CONTROLS

Electric Drive: Have a licensed electrician provide power to the machine per the National Electrical Code ANSI/NFPA 70 and local codes. For customer safety and ease of use, a motor disconnect switch may be mounted on the conveyor depending on options ordered.

Conveyors supplied with cord kits and/or used with USC control packages can be directly wired or plugged into the USC control panels for controlling on/off and supplying motor overload protection. **If conveyor is not controlled by a USC control panel, end-user will be responsible for ensuring that motor thermal overload protection is provided.**

- **Manual Winch:** A winch is located on the transport frame and is used to raise and lower the conveyor. Turn the handle clockwise to raise and counterclockwise to lower.



Maintain at least 3 wraps of cable on the drum at the maximum reach. The drum cable clamp is not designed to hold load.

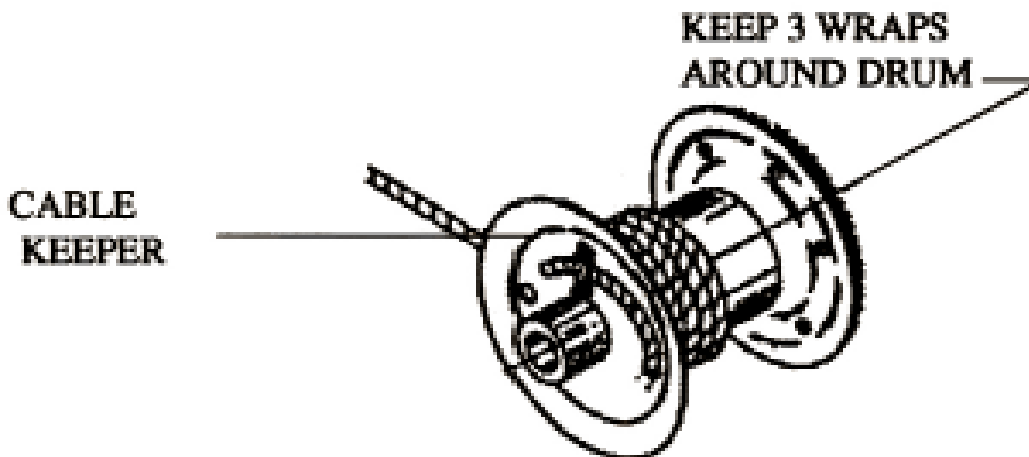

PRE-OPERATION CHECKLIST

Efficient and safe operation of the Tube Series Conveyor requires that each operator reads and understands the operating procedures and all related safety precautions outlined in this section. A pre-operation checklist is provided for the operator. It is important for both the personal safety and maintaining the good mechanical condition of the Conveyor that this checklist is followed.

Before operating the Conveyor and each time thereafter, the following areas should be checked off:

1. Check belt alignment and tension. Adjust as outlined on page 82
2. Service the machine per the schedule outlined in Section F, Maintenance (Page 79).
3. Use only an electric motor of adequate power to operate the machine.
4. Check that all guards are installed, secured and functioning as intended. Do not operate with missing or damaged shields.
5. Check worksite. Clean up working area to prevent slipping or tripping.
6. Check winch and cable for security and operation. There should be at least 3 complete wraps of cable around winch drum in full down position. Cable anchor on winch drum must be tight. Inspect cable for fraying or damage and replace if damaged or frayed.
7. Check that cable clamps are secure.
8. Check that drive belt and conveying belt are not frayed or damaged and that they are properly adjusted and aligned.
9. Be sure Conveyor wheels are chocked.
10. Check that discharge and intake areas are free of obstructions.



Anchoring and / or support of Conveyor during operation is necessary. When the lower half of Conveyor empties of material, the weight balance transfers to the upper end of the machine, which can cause upending.

CONVEYOR SET-UP

The following steps outline the initial set-up of your Tube Series Conveyor:

1. Clear the area of bystanders, especially small children, before starting.
2. Be sure there is enough clearance from overhead obstructions and power lines or other equipment to move the machine into its working position.
3. Attach the Conveyor to an appropriate towing vehicle.
4. Move conveyor as near as possible to desired position.
5. Set the park brake on the towing vehicle before dismounting.
6. Unhook the unit from the towing vehicle.
7. Use the winch to raise the machine so it clears the truck, trailer or wagon.
8. Place chocks in the front and rear of each wheel.
9. It will be necessary to stake or weight the intake end to prevent upending when the machine is emptying.
10. Review the Workplace Safety Diagram for your model prior to starting work. Follow all setup instructions and do not allow any unauthorized people into the working area.
11. Have a certified electrician provide power to the conveyor. Provide convenient shutdown switches and comply with local electrical codes. The conveyor may also be plugged directly into a USC seed treater control panel.

 **WARNING** Ensure that the seed treater panel and the conveyor are rated for the same power before plugging the conveyor into the seed treater panel.

12. Reverse the above procedure when removing the machine from its working position.

USC CONVEYORS
STRUCTURAL ENVELOPE

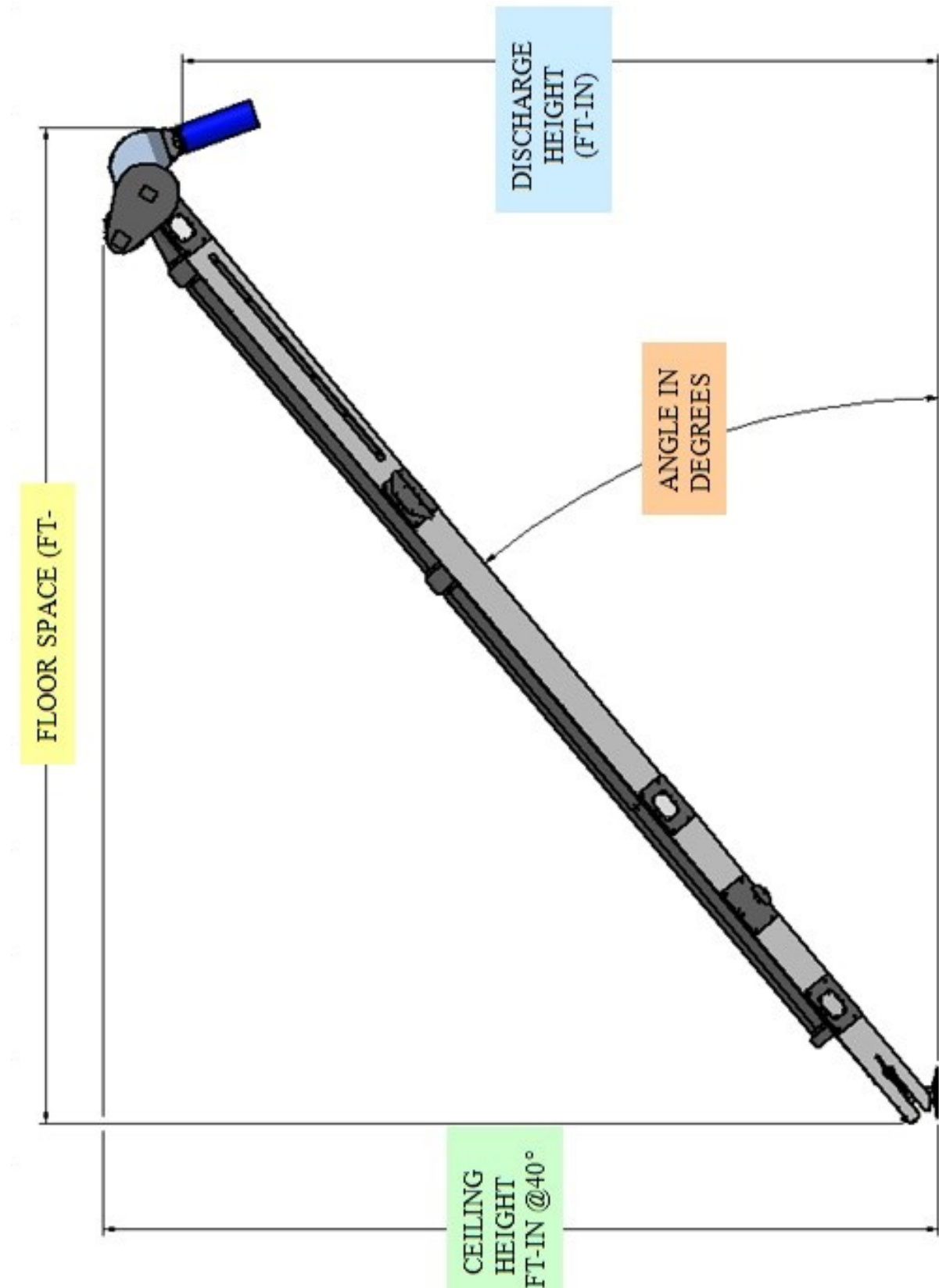

USC CONVEYORS

Conveyor Lengths	Angle in Degrees				
	26°	28°	30°	32°	34°
20	N/A	N/A	9-5	10	10-8
	N/A	N/A	19-1	18-8	18-4
	N/A	N/A	11-8	12-3	12-10
25	N/A	10-4	11-11	12-8	13-5
	N/A	24-6	23-4	22-11	22-6
	N/A	12	14-2	14-11	15-7
30	9-7	12-6	14-5	15-4	16-3
	29-10	28-8	27-8	27-2	26-7
	12-2	14-11	16-8	17-7	18-5
35	11-3	14-8	16-11	18	19
	34-6	33-2	32-7	31-5	30-9
	13-11	17-1	18-2	20-2	21-2
40	13	16-11	19-5	20-8	21-10
	39-3	37-8	36-4	35-8	34-11
	15-7	16-10	21-9	22-10	24
45	14-8	19-1	21-11	23-3	24-7
	43-11	42-2	40-8	39-11	39-1
	17-4	20-2	24-2	25-6	26-9

*** ALL DIMENSIONS ROUNDED DOWN TO NEAREST INCH**
**** N / A - INFORMATION NOT AVAILABLE**

USC CONVEYORS

MACHINE BREAK-IN

Although there are no operational restrictions on the Conveyor when used for the first time, it is required that the following mechanical items be checked. A small amount of rubber flashing from the conveyor belt may be present during initial belt break-in period. This is part of the normal break-in process.

BEFORE STARTING

1. Read the Conveyor Operator's Manual.
2. **During the conveyors first few minutes of operation, before any seed is run through, it is essential that the operator check conveyor belt tension and alignment and make any necessary adjustments (see pages 82 - 84).**

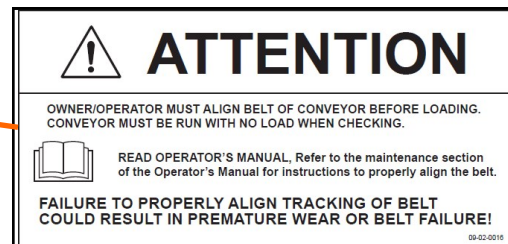
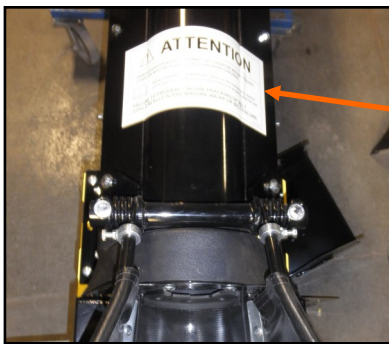

Part # 09-02-0016

AFTER OPERATING OR TRANSPORT FOR 1/2 HOUR

1. Re-torque all the wheel bolts.
2. Re-torque fasteners and hardware.
3. Check that all safety decals are installed and legible. Apply new decals if required.
4. Check the drive belt tension and alignment. Tension or align as required.
5. Check the conveying belt tension and alignment. Tension or align as required.
6. Check that all guards are installed and working as intended.

AFTER OPERATING FOR 5 HOURS AND 10 HOURS

1. Re-torque all wheel bolts, fasteners and hardware.
2. Check that all guards are installed, secured and functioning as intended. Do not operate with missing or damaged shields.
3. Check safety decals. Install new ones if required.
4. Check the drive belt, and conveying belt tension and alignment. Tension or align as required.
5. Then go to the normal servicing and maintenance schedule as defined in the Maintenance Section.

USC CONVEYORS

OPERATION

When using the conveyor, follow this procedure:

1. Clear the area of bystanders, especially small children, before starting.
2. Review the Pre-Operation Checklist (see page 67) before starting.
3. Review the Workplace Hazards schematic and use extra care when inside the hazard area. Keep all bystanders out of this area. Should anyone enter this area, stop the machine immediately.
4. Set the conveyor in position. To achieve rated capacity, the conveyor should be run **no steeper than 30° for SS16 and TS25 and 40° for TS35**. Molded flights on the belt minimize material rollback during operation.
5. Drive or back the truck or wagon into position for unloading.
6. Turn the electric motor ON and begin the flow of material and unload.
7. To stop the conveyor; stop the flow of material and run until the belt is empty. Turn off motor and lock out power source.

EMERGENCY STOPPING

Although it is recommended that the machine be emptied before stopping, in an emergency situation, stop or shutdown the power source immediately. Correct the emergency before resuming work.

RESTARTING

When the machine is shut down inadvertently or for an emergency, the belt may still be covered with material. It may be necessary to tighten the drive belt slightly to handle the heavier-than-normal starting loads.

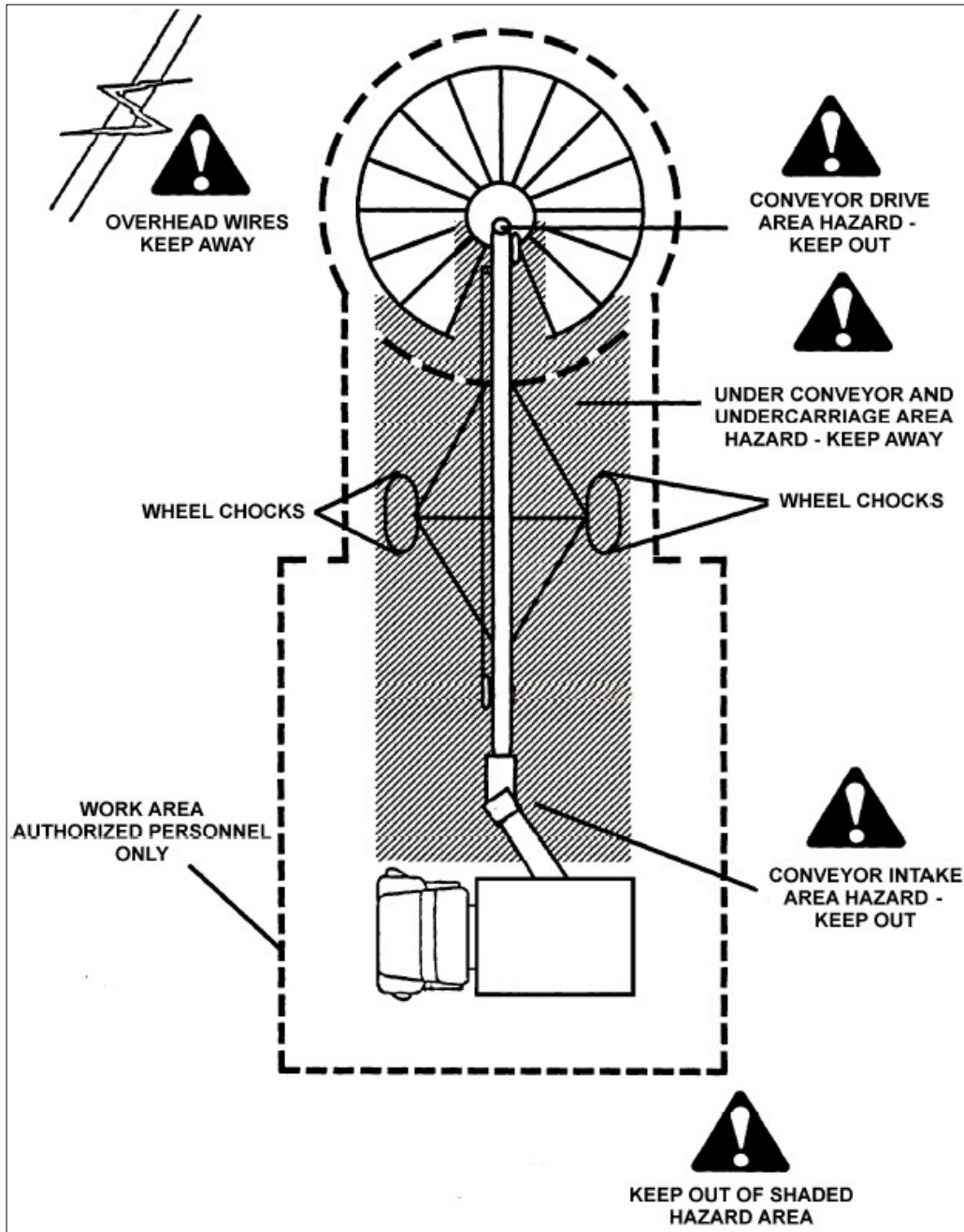

OPERATIONAL HINTS

- **USC strongly recommends not using the conveyor at or below freezing temperatures. If you do, use the following start-up procedure:**
 1. Turn the conveyor ON and OFF several times to bump the conveyor belt. If any ice has formed on or around the belt, this should break the belt free. If the belt does not move, wait for the outside temperature to increase.
 2. Once the belt is moving freely, let it run for 4 or 5 minutes to allow it to warm up.
 3. At the end of the warm-up period, verify that the belt has the correct tension and is aligned properly. If it is not, follow the tension and alignment instructions outlined in the Maintenance Section to make the necessary adjustments (see page 82).
 4. Direct the flow of material into the inlet hopper when moving material. Do not “flood feed” the inlet hopper.
- Always listen for any unusual sounds or noises. If any are heard, continue to run for a short time to allow any material to clear from the conveyor. If you still hear the sound, stop the machine and determine the source. Correct the problem before resuming work.
- Never allow anyone into the workplace hazard area. If anyone enters, stop immediately. Make them LEAVE before resuming work.
- Do not run the machine for long periods of time with no material on the belt. It increases the wear. Try to run the conveyor only when moving material.
- Do not support the discharge end directly on the bin, truck box, trailer or wagon. Stake the intake (hopper) or weight it down to prevent upending.
- Use a Truck Unload Conveyor or similar conveyor to move grain from under the bin discharge into the bin fill conveyor hopper when emptying low clearance facilities.

ATTACHING AND UNHOOKING

It is recommended that the Tube Series Conveyor be attached to an appropriate towing vehicle whenever it is moved. Follow this procedure when attaching to or unhooking from a towing vehicle:

1. Make sure that bystanders, especially small children, are clear of the working area.
2. Be sure the conveyor wheels are chocked.
3. Be sure that there is sufficient room and clearance to back up to the machine.
4. Align the drawbar of the towing vehicle with the hitch of the Conveyor while backing up.
5. Set the park brake before dismounting.
6. Lower conveyor to lowest position.
7. Place hitch pin on conveyor to the lowest hole.
8. Align the hitch to the drawbar and install a hitch pin with a retainer (not supplied).
9. Remove chocks from machine wheels.
10. Move to new location.
11. Reverse the above procedure when unhooking.
12. Removal of the most forward pin will allow the conveyor to pivot on to the hitch plate so the hitch plate can be used as a base.

USC CONVEYORS

TRANSPORTING

The USC Conveyors are designed to be easily and conveniently moved from place to place. When transporting, follow this procedure:

1. Review the Transport Safety Schematic before starting.
2. Be sure all bystanders are clear of the machine.
3. On electric motor drive units, unplug the power cord, wrap around frame, and secure to prevent dragging.
4. Attach to a towing vehicle using a hitch pin with a retainer.
5. Remove chocks from the wheels.
6. Lower the conveyor into its fully down position so that the cross tube rests on the stop plate.



7. Stay away from over head power lines. Electrocutation can occur without direct contact.

8. Never go across slopes of more than 20°. It is better to go straight up or straight down a slope.

9. Make sure the SMV (Slow Moving Vehicle) emblem and all the lights and reflectors that are required by the local highway and transport authorities are in place, are clean, and can be seen clearly by all overtaking and oncoming traffic.
10. Keep to the right and yield the right-of-way to allow faster traffic to pass. Drive on the road shoulder, if permitted by law.
11. It is not recommended that the machine be transported faster than 25 mph (40 km/h).
12. Do not allow riders on the machine or towing vehicle.
13. During periods of limited visibility, use pilot vehicles or add extra lights to the machine.
14. Always use hazard flashers on the vehicle when transporting unless prohibited by law.

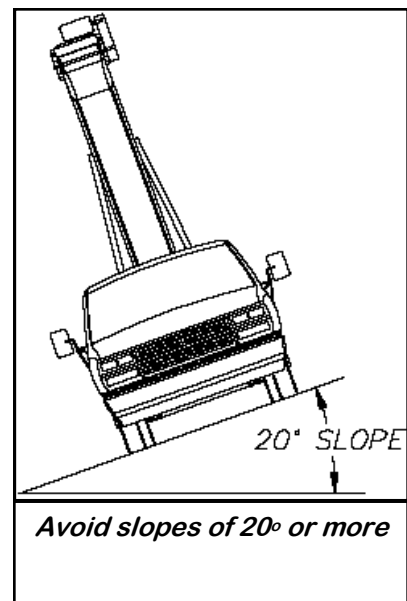
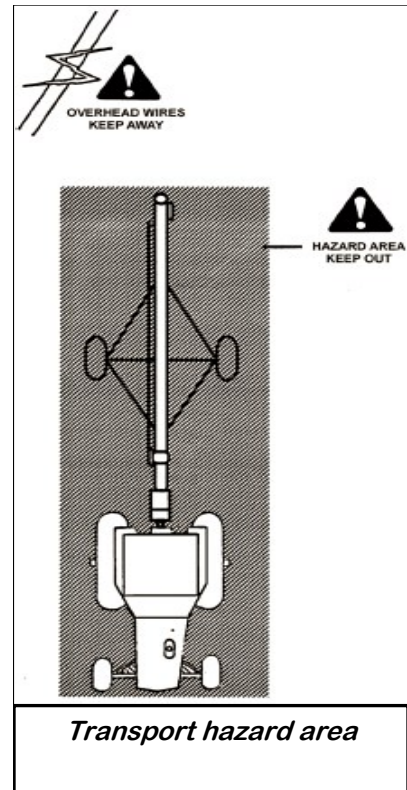

TROUBLESHOOTING **SECTION
E**

Below is a table describing the most frequent problems and solutions with the Tube Series Conveyor. For further assistance, contact your authorized dealer.

Problem	Possible Cause	Solution
Conveyor will not run.	<ol style="list-style-type: none"> 1. Not turned on. 2. Conveying belt loose. 3. Drive belt loose. 	<ol style="list-style-type: none"> 1. Start power source or turn on power. 2. Tighten and align belt. 3. Tighten drive belt.
Belt edge fraying.	<ol style="list-style-type: none"> 1. Belt not aligned. 	<ol style="list-style-type: none"> 1. Align and tension belt.
Low conveying capacity.	<ol style="list-style-type: none"> 1. Angle too steep. 2. Slow operating speed. 3. Conveyor belt slipping. 4. Drive belt slipping. 	<ol style="list-style-type: none"> 1. SS16, TS25 Reposition with angle at 30°. TS35 Reposition with angle less than 40°. 2. Increase operating speed. 3. Tighten belt. 4. Set drive belt tension.

USC CONVEYORS

UNPLUGGING

In unusual moisture or material conditions, the machine can plug. When unplugging, follow this procedure:

1. Place all controls in neutral or off, stop motor, disable and lock out power source before unplugging.

2. Remove the nut, bolt and sliding clean out door from the bottom of the inlet tube section of the conveyor. Remove any built up material. Reinstall door and hardware.



Sliding Clean Out Door

3. Open the tail cover (below).
4. Remove plugged material.
5. Install and secure conveyor and tail covers.

*Remove shipping bolts
after receiving
conveyor*

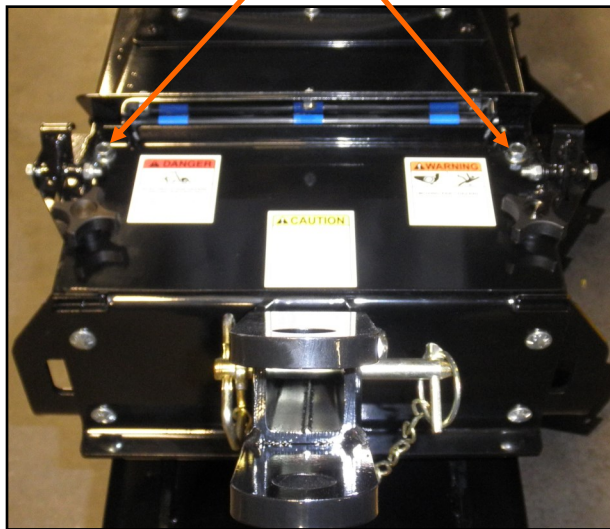

Bottom clean-out cover

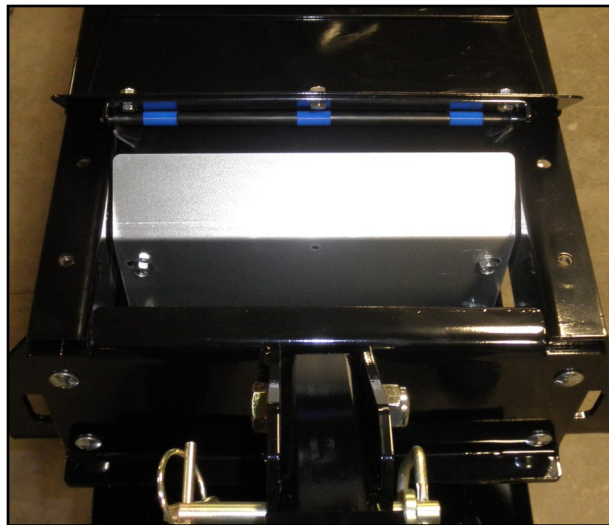

Bottom clean-out cover removed

MAINTENANCE

SECTION F

Proper maintenance of the Tube Series Conveyors is critical for peak performance, reliability and accuracy of this system. The following is a guideline for the type of maintenance and servicing that should be performed on this unit. Your environment and uses may require additional maintenance and service beyond this list to assure a reliable and safe unit. The operator of this unit has ultimate responsibility to identify areas of concern and rectify them before they become a hazard or safety issue. There is no substitute for a trained, alert operator.



DANGER Do not put this unit into operation with any questionably maintained parts. Poor performance or a hazard may occur.



DANGER Do not use compressed air or water under pressure to clean any of the components of the USC equipment.



WARNING Failure to maintain the proper belt tension will cause the belt to slip. This will damage the belt and head drive pulley. If the belt is not tracking correctly, it can ride along one edge causing the belt to fray and damage the belt splice. Either problem will cause the belt to burn or wear out prematurely.

GREASING

Use an SAE multipurpose high temperature grease with extreme pressure (EP) performance. Also acceptable is an SAE multipurpose lithium-based grease.

- Use a Maintenance Checklist to keep record of all scheduled maintenance.
- Use a hand-held grease gun for all greasing.
- Wipe grease fitting with a clean cloth before greasing to avoid injecting dirt and grit.
- Replace and repair broken fittings immediately.

Storing Lubricants

Your machine can operate at top efficiency only if clean lubricants are used. Use clean containers to handle all lubricants. Store them in an area protected from dust, moisture and other contaminants.



If fittings will not take grease, remove and clean thoroughly. Also clean lubricant passageway. Replace fitting if necessary.

CONVEYOR SERVICING INTERVALS

Every 40 hours or Weekly

1. Check the conveyor belt tension and alignment.
2. Grease conveyor bearings.
 - A. Two bolt flanged bearings, tail roller bearings right and left (2 locations).
 - B. Two bolt flanged bearings, drive roller bearings right and left (2 locations).
3. Remove guard and check the drive belt tension and alignment. The belts will deflect approximately 1/4 to 1/2 inch when properly tensioned.
4. Wipe down the motor casing with a damp cloth making sure to remove all dust that may have collected since the last maintenance date. Record the cleaning on the company required documents

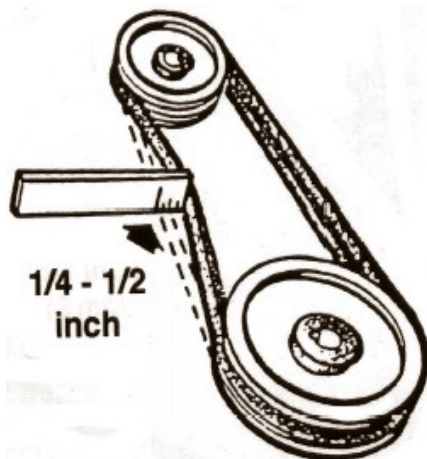

Every 200 hours or Annually

1. Repack wheel bearings.
2. Wash machine.
3. Check pulley bushing for wear. To inspect pulley:
 - A. Lower the conveyor to its lowest position.
 - B. When the conveyor has reached the lowest position, it will stop at the pins.
 - C. Unwind the winch two more turns, or until enough slack in the cable is achieved.
 - D. Loosen and remove the bolt.
 - E. Inspect the bushing on the pulley for wear.
 - F. Reverse steps A-D for re-assembly.

CONVEYING BELT TENSION AND ALIGNMENT - TAIL END

A contoured belt with molded flights is used to convey material along the frame. The tension and alignment of the belt should be checked weekly, or more often if required, to be sure that it does not slip or run to one side. A properly tensioned belt will not slip when it is operating. Operating the belt with less slippage will increase the belt life and causes less stress on bearings, pulleys and shafts.



WARNING

Although it is acceptable to align the belt from either the Head or the Tail (Intake) end. Tightening the belt may only be done from the Tail end of the conveyor.

CONVEYING BELT TENSION AND ALIGNMENT - TAIL END

To maintain the belt, follow this procedure:

NOTICE

Place all controls in neutral or off, stop motor and disable power source before working on belt.

1. Use the take-up bolt located at the tail to set the tension of the belting.
2. If the belt needs to be tightened to prevent slippage, use the take-up adjustments on the tail end only.
3. The belt is tightened by turning both take-up adjustments an **equal** number of turns.
4. Use the drive roller to check the alignment. The belt should be centered.
5. Turn the belt 1/2 revolution when the belt is new and check the drive and tail roller. If out of alignment, the belt will move to the loose side. Loosen the jam nut and use the bearing position bolts to set the position. Tighten jam nut.
6. Run and check again. Check frequently during the first few minutes of operation and then several times during the first 10 hours. The belt normally seats itself during the first 10 hours of operation and can be checked weekly after that.
7. The belt is properly aligned when the belt runs in the center of the head and tail rollers.

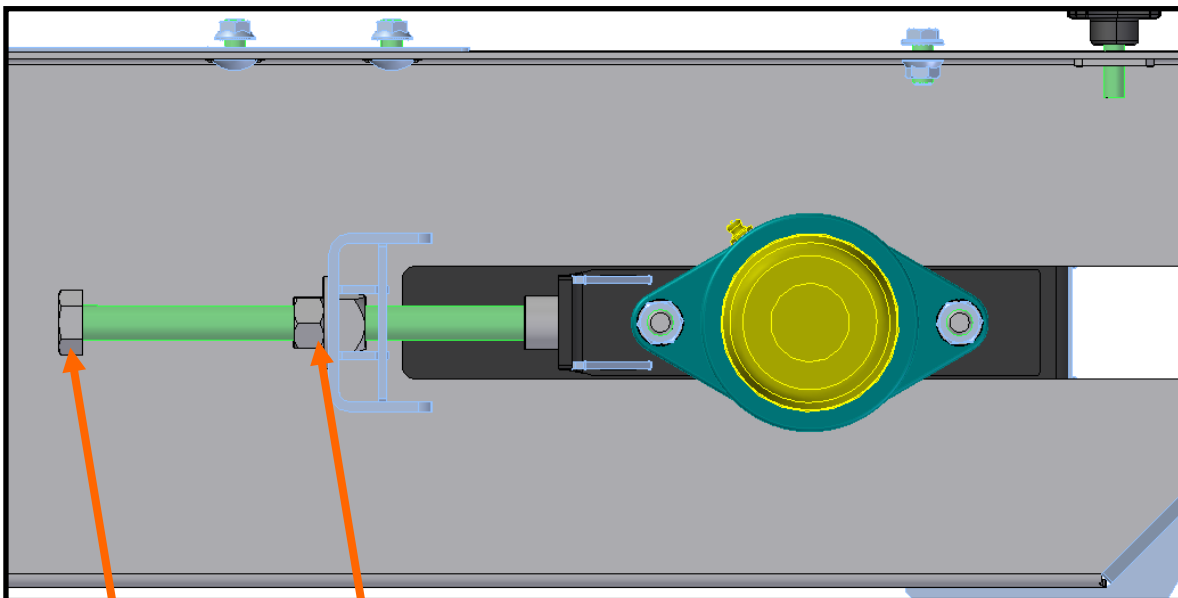

Use this bolt to tighten and align the belt

This nut will free and secure adjustment bolt.

CONVEYING BELT ALIGNMENT - HEAD END

1. A misaligned belt will track toward the loose side. Set the tracking by loosening the bearing mounts on the tight side and using the bearing position bolt to move the end of the head roller toward the tail. Tighten the bearing mount when the belt is centered on the head roller.
2. Run the belt and check the tracking again. Loosen the tight side slightly again if required. Repeat the adjusting and checking procedure until the belt centers on the inlet end roller and remains centered when running.
3. Always repeat this aligning procedure when installing a new belt. Check frequently during the first 10 hours of operation. After 10 hours, the belt is normally seated and checking the alignment can be done less frequently.

*Tighten jam nuts
after adjustment*

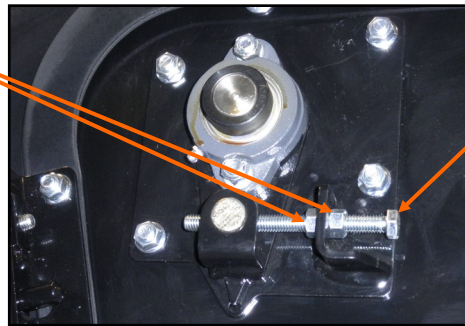

*Use this bolt to
align the belt*

BELT REPLACEMENT

1. Rotate the belt until the seam is visible.
2. Move the tail roller to its loosest position.
3. Pull all the slack to the seam area.
4. Remove the wire connector and open the belt.
5. Attach one end of the replacement belt to the belt end being removed.
6. Pull the old belt out and the new belt will be threaded into place.
7. Disconnect the old belt.
8. Connect the ends of the new belt together and secure.
9. Set the belt tension.
10. Check and set the belt alignment

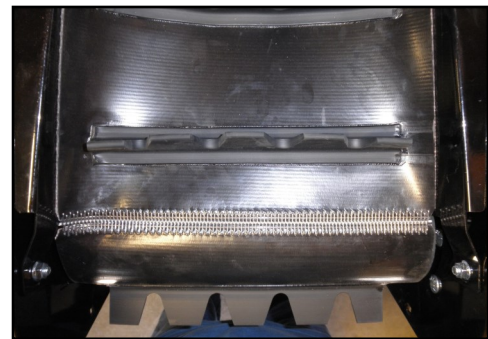

Belt Seam

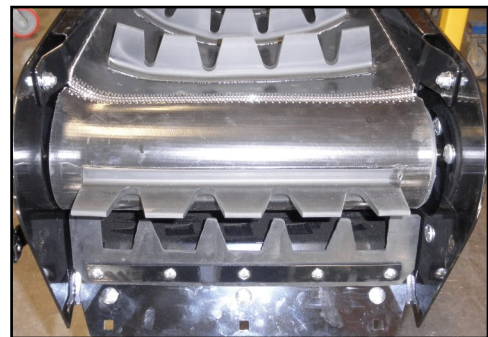

Check Alignment

DRIVE BELT TENSION & ALIGNMENT

Power to the conveying belt is transmitted through a V-belt. The V-belt drive system must be maintained at the proper belt tension and pulley alignment to obtain the desired performance and life. When maintaining the belt drive system for the electric drive model, follow this procedure:

NOTICE

Turn motor off and unplug power cord or turn off power and lock out the master panel before starting maintenance on drive belt system.

Drive Belt Tension

1. Push on the center of the belt span with a force of approximately 5 to 10 lbs.
2. Follow the belt tensioning specification on page 85 to determine proper belt deflection.
3. Move the motor up, using the adjustment bolt, to set drive belt tension (right).
4. Close and secure guards.

Drive Belt Alignment

1. Lay a straightedge across the pulley faces to check the alignment (right).
2. Use the pulley hub or the motor mounting plate slots to move the pulley to the required position for alignment.
3. Tighten hub bolts to secure pulley on shaft.
4. Check belt tension
5. Close and secure guards.

Drive Belt Replacement

1. Lower motor to its lowest position.
2. Remove old belt and replace with a new one.
3. Raise motor to set the belt tension.
4. Check pulley alignment. Adjust if required.
5. Close and secure guards.

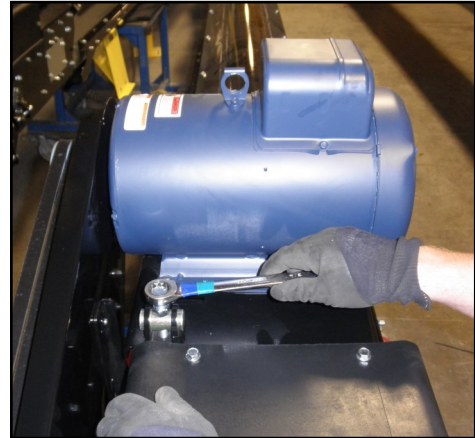

Motor base adjustment



Lay a straightedge across

USC CONVEYORS

V-Belt tensioning adjustment can be made using a tension meter or other type spring scale using the following procedure. After seating the belts in the groove and adjusting center distance so as to take up the slack in the belts, further increase the tension until only a slight bow on the slack side is apparent while the drive is operating under load. Stop the drive and using the meter, measure the force necessary to depress one of the center belts 1/64 inch for every inch of belt span (see sketch below). For example, a deflection for a 50 inch belt span is 50/64 or 25/32 inch. The amount of force required to deflect the belt should compare with the deflection forces noted in the table below. Also notice for V- Belts that deflection forces vary from the initial RUN - IN values which are greater (reflecting higher run-in tensioning) to the NORMAL values for after the run-in period.

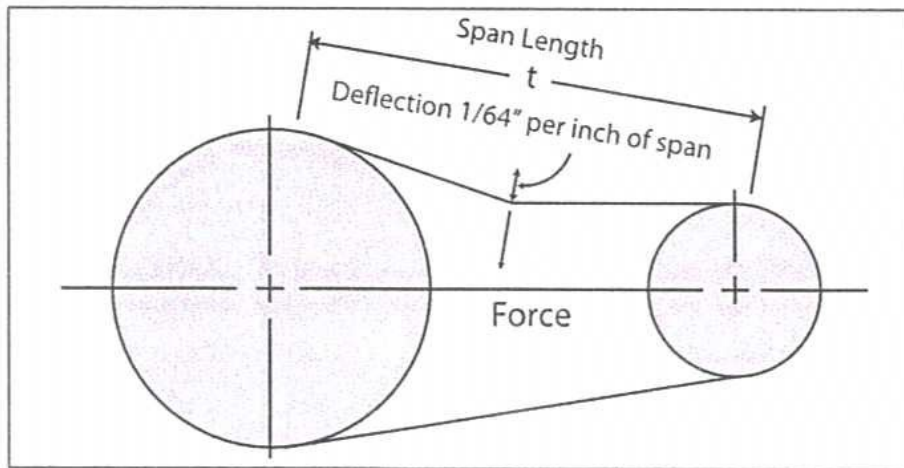

MEASURE THE SPAN LENGTH "T" AS SHOWN IN THE SKETCH ABOVE.

BELT CROSS SECTION	SMALLER PULLEY DIAMETER RANGE (inches)	DEFLECTION FORCE	
		RUN - IN (lbs.)	NORMAL (lbs.)
AX	3.0 - 3.6	4 - 1/8	2 - 3/4
	3.8 - 4.8	5	3 - 1/4
	5.0 - 7.0	6	4
BX	3.4 - 4.2	5 - 1/4	3 - 1/2
	4.4 - 5.2	7 - 1/8	4 - 3/4
	5.4 - 9.4	9	6

SECTION
G**STORAGE**

When storing the USC Conveyors for long periods of time, the following procedure must be followed to reduce the chance of rust, corrosion and fatigue of the conveyor. You can also use these steps when storing the machine for the winter.



A dust mask and protective rubber gloves shall be used when cleaning the machine.

1. Clear the area of bystanders, especially small children.
2. Thoroughly wash the entire machine to remove all dirt, mud, debris or residue.
3. Inspect all moving or rotating parts to see if anything has become entangled in them. Remove the entangled material.
4. Lubricate all grease fittings. Make sure that all grease cavities have been filled with grease to remove any water residue from the washing. This also protects the bearing seals.
5. Remove drive assembly cover. Clean entire area and ensure drive belt is clean and free of debris.
6. Touch up all paint nicks and scratches to prevent rusting.
7. Select an area that is dry, level and free of debris.
8. If possible, store the machine inside a protective building to keep it from being exposed to the weather. If storing outside, cover the entire machine with a large waterproof tarpaulin. If you do not have one large enough, at a minimum cover all electric motors.
9. Unhook from towing vehicle.
10. Place blocks under the intake or the jack if required.
11. Store machine in an area away from human activity.
12. Do not allow children to play on or around the stored machine.

USC CONVEYORS

NOTES:

SECTION H LIMITED WARRANTY

Rev II 01AUG20

USC, LLC, (Manufacturer) warrants its seed treating equipment as follows:

1. Limited Warranty: Manufacturer warrants that the Products sold hereunder will be free from defects in material and workmanship for a period of 18 months from date of shipment. Manufacturer further provides a 12 month warranty on specific equipment supplied with a warranty card. The 12 month warranty begins upon USC receipt of warranty card from Wholesaler and must be submitted to USC within 18 months of stock equipment purchase by wholesaler to be valid. If the Products do not conform to this Limited Warranty during the warranty period, consumer shall notify Manufacturer in writing (on the approved USC warranty claim form) of the claimed defects and demonstrate to Manufacturer satisfaction that said defects are covered by this Limited Warranty (through pictures, video or other objective data). If the defects are properly reported to Manufacturer within the warranty period, and the defects are of such type and nature as to be covered by this warranty, Manufacturer shall, at its expense, furnish replacement Products or, at Manufacturer's option, replacement parts for the defective products. Shipping and installation of the replacement Products or replacement parts shall be at the Consumer's expense. All replacement parts orders through USC will carry their specific manufacturer's standard warranty including serialized parts manufactured by USC. USC will not warrant parts outside of the standard USC warranty period. USC will not extend any warranty due to replaced parts. The end user is responsible for all shipping and handling expenses for parts returned to USC under this section which may or may not be included in that specific warranty. USC will pay shipping expense between USC's vendor and USC.

2. Other Limits: THE FOREGOING IS IN LIEU OF ALL OTHER WARRANTIES, EXPRESSED OR IMPLIED, INCLUDING BUT NOT LIMITED TO THE IMPLIED WARRANTIES OF MERCHANTABILITY AND FITNESS FOR A PARTICULAR PURPOSE. Manufacturer does not warrant against damages or defects arising from improper installation (where installation is by persons other than Manufacturer), against defects in products or components not manufactured by Manufacturer, or against damages resulting from such non-Manufacturer made products or components. Manufacturer passes on to the consumer the warranty it received (if any) from the maker of such non-Manufacturer made products or components. This warranty also does not apply to Products upon which repairs and / or modifications have been affected or attempted by persons other than pursuant to written authorization by Manufacturer. This includes any welding on equipment which could damage electrical components. Manufacturer does not warrant against casualties or damages resulting from misuse and / or abuse of Products, improper storage or handling, acts of nature, effects of weather, including effects of weather due to outside storage, accidents, or damages incurred during transportation by common carrier or Dealer/customer arranged freight. Any replacement or repair covered under this warranty will **not** extend the warranty period. The remainder of the manufacturer's warranty will remain in force until stated expiration from point of sale.

3. Exclusive Obligation: THIS WARRANTY IS EXCLUSIVE. The sole and exclusive obligation of Manufacturer shall be to repair or replace the defective Products in the manner and for the period provided above. Manufacturer shall not have any other obligation with respect to the Products or any part thereof, whether based on contract, tort, strict liability or otherwise. Under **no** circumstances, whether based on this Limited Warranty or otherwise, shall Manufacturer be liable for lost profits, lost revenue, lost sales (whether direct or indirect damages), incidental, special, punitive, indirect or consequential damages. Consumer shall make no claims for remuneration for any loss as a result of USC equipment and USC shall reject any and all claims that may arise as stated herein.

4. Other Statements: Manufacturer's employees or representatives' oral or other written statements do not constitute warranties, shall not be relied upon by consumer, and are not a part of the contract for sale or this limited warranty. The USC Warranty Manager is the final decision point for all warranty claims.

5. Return Policy: Approval is required prior to returning goods to Manufacturer irrespective of warranty claim. A restocking fee will apply to all goods that are returned in new, sellable condition. Items returned for warranty that are found to be in new, sellable condition (not failing) will remain the property of the consumer and warranty claim for such items will be denied. The consumer will have the ability to have part returned at the consumer's expense or restocked at 15% restocking fee less any USC paid freight for its return.

6. Entire Obligation: This Limited Warranty states the entire obligation of Manufacturer with respect to the Products. If any part of this Limited Warranty is determined to be void or illegal, the remainder shall remain in full force and effect.



DOCUMENT REVIEW RECORD	
DATE	BY
04-2020	BT
07-2020	BT
01-2021	BT

USC LLC

2320 124th Road

Sabetha, KS 66534

PHONE: (785) 431-7900

EMAIL: sales-team@uscllc.com

WEB: www.uscllc.com

