

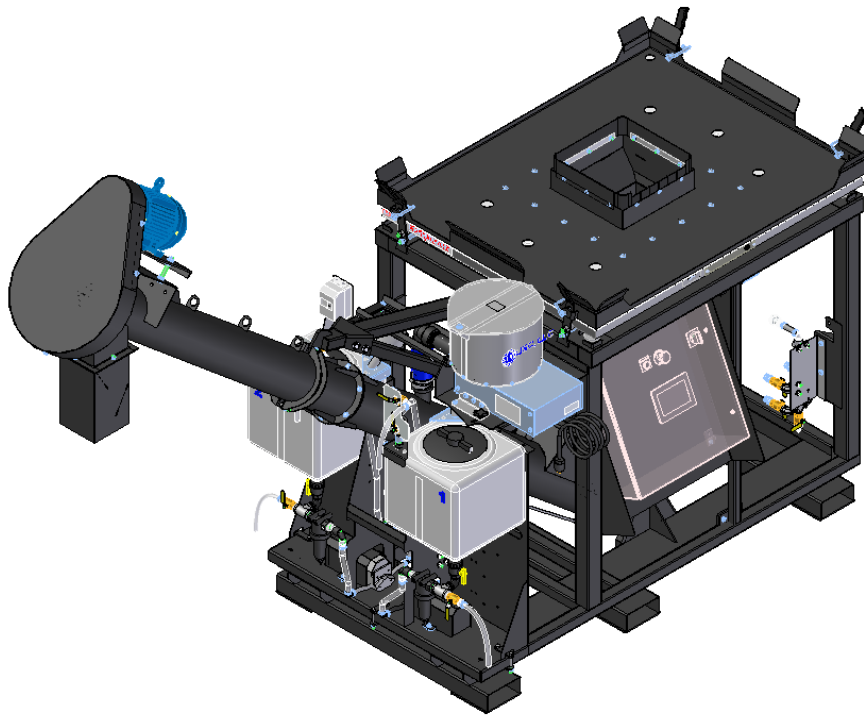

AT500H AUTOMATED TREATER W/LOSS IN WEIGHT SEED METERING



Operators Manual

Software Release: AT500 v2.1

Document: TD-09-06-1078

Revision: B

Effective Date: JAN 2023

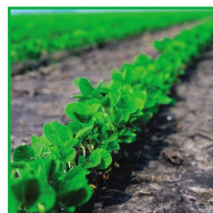

INTRODUCTION

Thank you for choosing USC, LLC for your equipment needs. We appreciate your business and will work diligently to ensure that you are satisfied with your choice.

OVERVIEW

The purpose of this manual is to provide you with the basic information needed to operate and maintain the AT500H Automated Treater. It does not hold USC, LLC liable for any accidents or injuries that may occur.

The technical information provided in this document is based on extensive testing under controlled conditions at the USC research and development facility. This information is given without guarantee as the conditions of operation and storage of the equipment are beyond our control. Variables such as temperature, humidity, viscosity of chemical products and changes in seed size or variety may all effect the accuracy of application and seed coverage. Periodically check the equipment calibration while treating and make adjustments as required. This will insure the optimum seed coverage.

RECEIVING YOUR EQUIPMENT

As soon as the equipment is received, it should be carefully inspected to make certain that it has sustained no damage during shipment and that all items listed on the packing list are accounted for. If there is any damage or shortages, the purchaser must immediately notify USC, LLC. Ownership passes to purchaser when the unit leaves the USC, LLC. premises. The purchaser is responsible for unloading and mounting all components of the equipment.

Document the serial number of the machine for future reference. The serial number is located on the frame above the treater control panel.

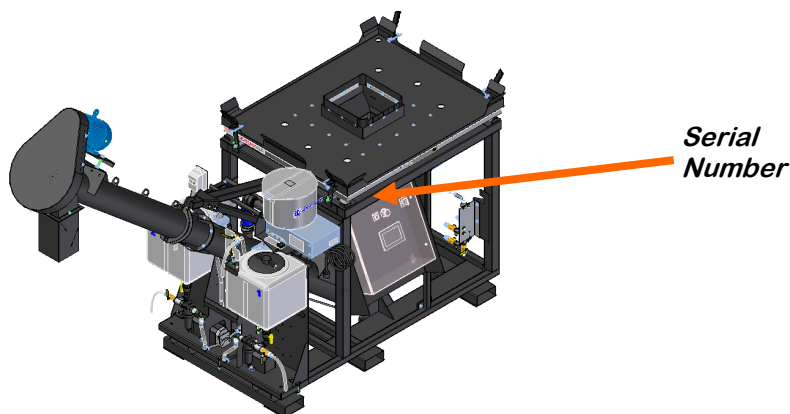

SERIAL NUMBER: _____

TABLE OF CONTENTS

<u>Section</u>	<u>Contents</u>	<u>Page #</u>
Section A	Safety Instructions	4
	Safety Labels	11
Section B	Installation	14
	Main Control Panel Connections	16
Section C	Mechanical Operation	18
	AT500H Automated Treater Overview	18
	Loss In Weight Slide Gate and Atomizer Overview	19
	Peristaltic Pump Head and Motor	20
	Seed Treatment Valves	21
	Flow Meters	22
Section D	Electrical Operation	23
	Main Screen	24
	H-O-A Screen	28
	Profile Editing Screens	32
	Reports Screen	33
	Customers	34
	Ingredients	35
	Seed Profiles	36
	Recipes	37
	Events Screen	38
Section E	Calibration & Operation	39
	Load Cell Calibration	39
	Seed Flow Calibration	41
	Flow Meter Calibration	43
	Treating seed	45
Section F	Troubleshooting	48
	Proximity Sensor Adjustment Guide	51
Section G	Maintenance	52
	Atomizer	53
	Belt Tensioning and Alignment	54
	Belt Tensioning Specification	55
	Pumps—Plumbing-Flow Meter	56
Section H	Storage	58
Section I	Limited Warranty	61

SECTION A SAFETY INSTRUCTIONS

Every year accidents in the work place maim, kill and injure people. Although it may be impossible to prevent all accidents, with the right combination of training, operating practices, safety devices and operator vigilance, the number of accidents can be significantly reduced. The purpose of this section is to educate equipment users about hazards, unsafe practices and recommended hazard avoidance techniques.

SAFETY WORDS AND SYMBOLS

It is very important that operators and maintenance personnel understand the words and symbols that are used to communicate safety information. Safety words, their meaning and format, have been standardized for U.S. manufacturers and published by the American National Standards Institute (ANSI). The European Community (E.C.) has adopted a different format based on the International Standards Organization (I.S.O.) and applicable machinery directives. Both formats are presented below. Graphic symbols are not standardized but most manufacturers will use some variation of the ones seen in this manual.



Indicates an imminently hazardous situation which, if not avoided, **will** result in death or serious injury.



Indicates a potentially hazardous situation which, if not avoided, **could** result in death or serious injury.



Indicates a potentially hazardous situation which, if not avoided, **may** result in minor or moderate injury and/or property damage.



Provides additional information that the operator needs to be aware of to avoid a potentially hazardous situation.



Mandatory Lockout Power Symbol. Disconnect, lockout and tagout electrical and other energy sources before inspecting, cleaning or performing maintenance on this panel.



International Safety Alert Symbol. The exclamation point (!) surrounded by a yellow triangle indicates that an injury hazard exists. However, it does not indicate the seriousness of potential injury. The exclamation point (!) is also used with the DANGER, WARNING and CAUTION symbols so the potential injury is indicated.



Electrocution Hazard Symbol. This symbol indicates that an electrocution hazard exists. Serious injury or death could result from contacting high voltage.



International Electrocution Hazard. This symbol indicates that an electrocution hazard exists. Serious injury or death could result from contacting high voltage.



Mandatory Read Manual Action Symbol. (I.S.O. format) This symbol instructs personnel to read the Operators Manual before servicing or operating the equipment.



Mandatory Read Manual Action Symbol. This symbol instructs personnel to read the Operators Manual before servicing or operating the equipment.

Notice is used to notify people of important installation, operation or maintenance information which is not hazard related.

NOTICE

LOCKOUT / TAGOUT PROCEDURES

Lockout/Tagout is the placement of a lock/tag on an energy isolating device in accordance with an established procedure. When taking equipment out of service to perform maintenance or repair work, always follow the lockout/tagout procedures as outlined in OSHA Standard 1910.147. This standard “requires employers to establish a program and utilize procedures for affixing appropriate lockout devices or tagout devices to energy isolating devices and to otherwise disable machines or equipment to prevent unexpected energizing, start-up, or release of stored energy in order to prevent injury to employees.”

HAZARD REVIEW



Electrocution Hazard

Electrocution accidents are most likely to occur during maintenance of the electrical system or when working on or near exposed high voltage wiring. This hazard does not exist when the electrical power has been disconnected, properly locked, and tagged out.



Automatic Start Hazard

This equipment may be controlled by an automated system and may start without warning. Failure to properly disconnect, lockout, and tagout all energy sources of remotely controlled equipment creates a very hazardous situation and could cause injury or even death. PLEASE STAY CLEAR AND BE ALERT.



DANGER! RISK OF ELECTRIC SHOCK AND ARC FLASH

Avoid any alteration to the equipment. Alterations may produce dangerous situations, where serious injury or death may occur. This equipment shall be installed in accordance with local installation codes and applicable regulations which should be carefully followed in all cases. Authorities having jurisdiction should be consulted before installations are made. Owners/operators are responsible for knowing what requirements, hazards, and precautions exist with this equipment. Owners/operators are responsible for informing all personnel associated with the equipment and all who are in the general area of the equipment, the requirements, hazards, and precautions that exist with this equipment. Electrical equipment should be installed, operated, serviced, and maintained only by qualified personnel. A qualified person is one who has skills and knowledge related to the construction and operation of electrical equipment and its installation and has received safety training to recognize and avoid the hazards involved. Only appropriately trained persons who are familiar with and understand the contents of this manual and all other pertinent product documentation are authorized to work on and/or with this product. Owners/operators must ensure that all authorized persons have sufficient technical training, knowledge, and experience and be able to foresee and detect potential hazards that may be caused by using the product, by changing the settings and by the mechanical, electrical, and electronic equipment of the entire system in which the product is used. All persons working on and with the product must be fully familiar with all applicable standards, directives, and accident prevention regulations when performing such work. Servicing and maintaining the equipment should only occur if the equipment is deenergized and properly locked out and tagged out. If it is unfeasible to service or maintain the equipment while deenergized, the following standards shall be referenced to ensure safe practices are being followed and proper PPE is being used: 29 CFR § 1910.333 and 29 CFR § 1910.137. No responsibility is assumed by USC, LLC for any consequences arising out of the use of this material.

YOU are responsible for the **SAFE** operation and maintenance of your USC, LLC equipment . **YOU** must ensure that you and anyone else who is going to operate, maintain or work around the equipment be familiar with the operating and maintenance procedures and related **SAFETY** information contained in this manual. This manual will take you step-by-step through your working day and alert you to good safety practices that should be adhered to while operating the equipment

Remember, **YOU** are the key to safety. Good safety practices not only protect you, but also the people around you. Make these practices a working part of your safety program. Be certain that **EVERYONE** operating this equipment is familiar with the recommended operating and maintenance procedures and follows all the safety precautions. Most accidents can be prevented. Do not risk injury or death by ignoring good safety practices.

- Equipment owners must give operating instructions to operators or employees before allowing them to operate the machine, and at least annually thereafter per OSHA (Occupational Safety and Health Administration) regulation 1928.57.
- The most important safety device on this equipment is a **SAFE** operator. It is the operator's responsibility to read and understand **ALL** Safety and Operating instructions in the manual and to follow them. All accidents can be avoided.
- A person who has not read and understood all operating and safety instructions is not qualified to operate the machine. An untrained operator exposes himself and bystanders to possible serious injury or death.
- Do not modify the equipment in any way. Unauthorized modification may impair the function and/or safety and could affect the life of the equipment.
- Think **SAFETY!** Work **SAFELY!**

GENERAL SAFETY

1. Read and understand the operator's manual and all safety labels before operating, maintaining, adjusting or unplugging the equipment .
2. Only trained persons shall operate the equipment . An untrained operator is not qualified to operate the machine.
3. Have a first-aid kit available for use should the need arise, and know how to use it.

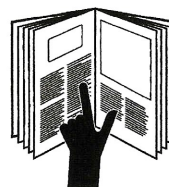

AT500H TREATER

4. Provide a fire extinguisher for use in case of an accident. Store in a highly visible place.
5. Do not allow children, spectators or bystanders within hazard area of machine.
6. Wear appropriate protective gear. This includes but is not limited to:
 - A hard hat
 - Protective shoes with slip resistant soles
 - Protective goggles
 - Heavy gloves
 - Hearing protection
 - Respirator or filter mask
7. Place all controls in neutral or off, stop motor, and wait for all moving parts to stop. Then disable power source before servicing, adjusting, repairing, or unplugging.
8. Review safety related items annually with all personnel who will be operating or maintaining the equipment.

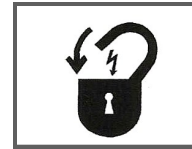

OPERATING SAFETY:

1. Read and understand the operator's manual and all safety labels before using.
2. Disconnect and disable electrical supply completely and wait for all moving parts to stop before servicing, adjusting, repairing or unplugging.
3. Clear the area of bystanders, especially children, before starting.
4. Be familiar with the machine hazard area. If anyone enters hazard area, shut down machine immediately. Clear the area before restarting.
5. Keep hands, feet, hair and clothing away from all moving and/or rotating parts.
6. Stay away from overhead obstructions and power lines during operation and transporting. Electrocution can occur without direct contact.
7. Do not operate machine when any guards are removed.
8. Inspect welds and repair if needed.

PLACEMENT SAFETY

1. Move only with the appropriate equipment
2. Stay away from overhead power lines when moving equipment. Electrocutation can occur without direct contact.
3. Be familiar with machine hazard area. If anyone enters hazard areas, shut down machine immediately. Clear the area before restarting.
4. Operate the equipment on level ground free of debris. Anchor the equipment to prevent tipping or upending.



Before placement of the equipment , be sure that ground is reasonably level. The equipment may topple or work improperly if the ground is too uneven, damaging the equipment and/or causing personal injury.

MAINTENANCE SAFETY

1. Review the operator's manual and all safety items before working with, maintaining or operating the equipment .
2. Place all controls in neutral or off, stop motors, disable power source, and wait for all moving parts to stop before servicing, adjusting, repairing or unplugging.
3. Follow good shop practices:
Keep service area clean and dry.
Be sure electrical outlets and tools are properly grounded.
Use adequate light for the job at hand.
4. Keep hands, feet, hair and clothing away from all moving and/or rotating parts.
5. Clear the area of bystanders, especially children, when carrying out any maintenance and repairs or making any adjustments.
6. Before resuming work, install and secure all guards when maintenance work is completed.
7. Keep safety labels clean. Replace any sign that is damaged or not clearly visible.



SAFETY LABELS

1. Keep safety labels clean and legible at all times.
2. Replace safety labels that are missing or have become illegible.
3. Replaced parts that displayed a safety label should also display the current label.
4. Replacement safety labels are available. Contact your authorized dealer

How to Install Safety Labels:

- Be sure that the installation area is clean and dry.
- Be sure temperature is above 50°F (10°C).
- Decide on the exact position before you remove the backing paper.
- Remove the smallest portion of the split backing paper.
- Align the sign over the specified area and carefully press the small portion with the exposed sticky backing in place.
- Slowly peel back the remaining paper and carefully smooth the remaining portion of the sign in place.
- Small air pockets can be pierced with a pin and smoothed out using the piece of sign backing paper.



Located on the USC equipment you will find safety labels. Always be sure to read and follow all directions on the labels.



Guards provided with USC equipment are to remain in place during operation.

Think **SAFETY!** Work **SAFELY!**

REMEMBER—If safety labels have been damaged, removed, become illegible, or parts replaced without safety labels, new labels must be applied. New safety labels are available from your authorized dealer.



Part # 09-02-0002



Part # 09-02-0003

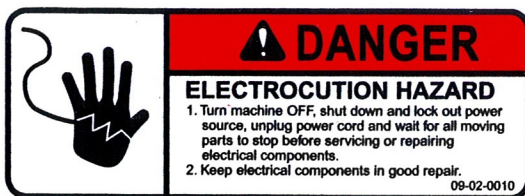

Part # 09-02-0010

AT500H TREATER



Part # 09-02-0001

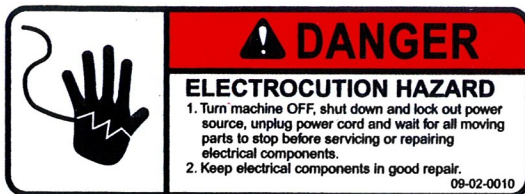
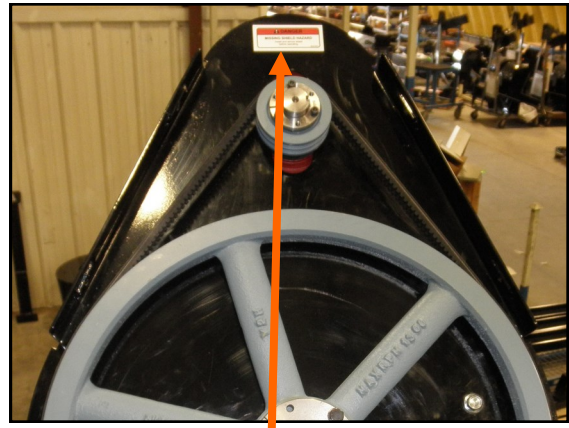

Part # 09-02-0010



Part # 09-02-0012

INSTALLATION

SECTION B



HIGH VOLTAGE ~ Always disconnect the power source before working on or near the control panel or lead wires.



HIGH VOLTAGE ~ Use insulated tools when making adjustments while the controls are under power.

NOTICE

Permanent installation may require additional electrical cords, chemical tubing, and air lines, since each installation is unique.

SET-UP

The following steps outline the initial set-up of your USC AT500H Treater :

1. Clear the area of bystanders, especially small children, before moving.
2. Be sure there is enough clearance from overhead obstructions and power lines or other equipment to move the machine into its working position.
3. Using a forklift, place the AT500H Treater in the desired position on a level surface.

NOTICE

USC highly recommends that the AT500H Treater be set up inside a building or any covered structure to protect the machine from weathering.

4. Inspect AT500 Treater thoroughly for screws, bolts, fittings, etc. which may have come loose during shipping.
5. Check and tighten hose connections.

AT500H TREATER

Sample Label →

⚠ WARNING ⚠
240V / 1-PHASE / 50/60 Hz SUPPLY ONLY
⚠ AVERTISSEMENT ⚠
240V / 1-PHASE / 50/60 Hz ALIMENTATION SEULEMENT



Mfg. By: USC, LLC
Max Voltage: 240V, 1PH, 50/60Hz
Total FLA: 30
Largest Motor FLA: 19
Schematic Number: 03-12-0636 B
Enclosure Rating: UL Type 1
SCCR: 5kA RMS Sym, 600V Max

- Have a certified electrician provide power to the seed treating system. Provide convenient shut-down switches, comply with local electrical codes and ensure that the system is properly grounded and bonded. All USC control panels must be connected adhering to the same electrical requirements as specified in the main control panel on the power requirement tag (right), or the electrical schematic shipped with the piece of equipment.

Incoming power connected to these terminals Located in the top right hand corner in the Treater Control Panel

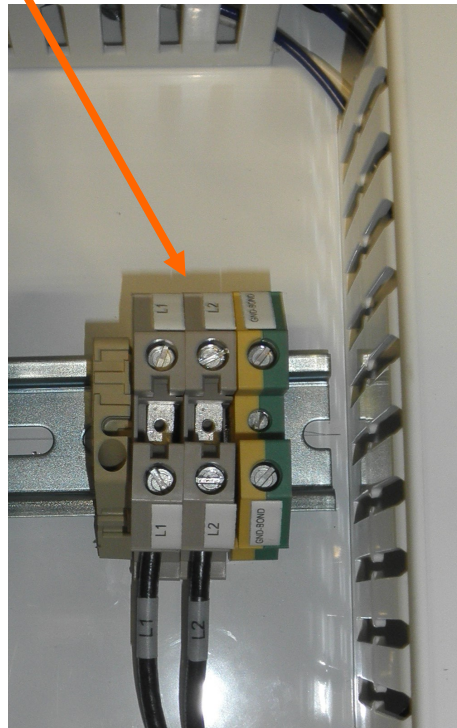

WARNING
To maintain over current, short-circuit and ground fault protection, the manufacturer's instruction for selection of overload and short circuit protection must be followed to reduce the risk of fire or electrical shock.

WARNING
If an overload or a fault current interruption occurs, circuits must be checked to determine the cause of the interruption. If a fault condition exists, the current-carrying components should be examined and replaced if damaged, and the integral current sensors must be replaced to reduce the risk of fire or electrical shock.

AVERTISSEMENT
Suivre les directives du fabricant pour protéger le système contre les surtensions, les courts-circuits et les défauts à la terre lors du choix des dispositifs de protection correspondants afin de réduire le risque d'incendie et de décharge électrique.

AVERTISSEMENT
En cas d'une interruption liée à une surtension ou à un courant de défaut, il convient d'inspecter les circuits afin d'identifier la cause de la panne. En cas de défaillance, les composantes qui transportent le courant doivent être examinées, puis remplacées si elles ont été endommagées, de même que remplacer les capteurs de courant intégral, afin de réduire le risque d'incendie et de décharge électrique.

Fuse Replacement Chart			
Tag	Code	Rating	Type
FU2011	2011	4A	1/8" TL 150VDC CERAM
FU2012	2012	4A	1/8" TL 150VDC CERAM
FU2013	2013	4A	1/8" TL 150VDC CERAM
FU2920	2920	0.5A	PA FS GGM .5

Quality Assurance
Approved by: _____
Mfg Date: _____

AT500H TREATER

MAIN CONTROL PANEL CONNECTIONS

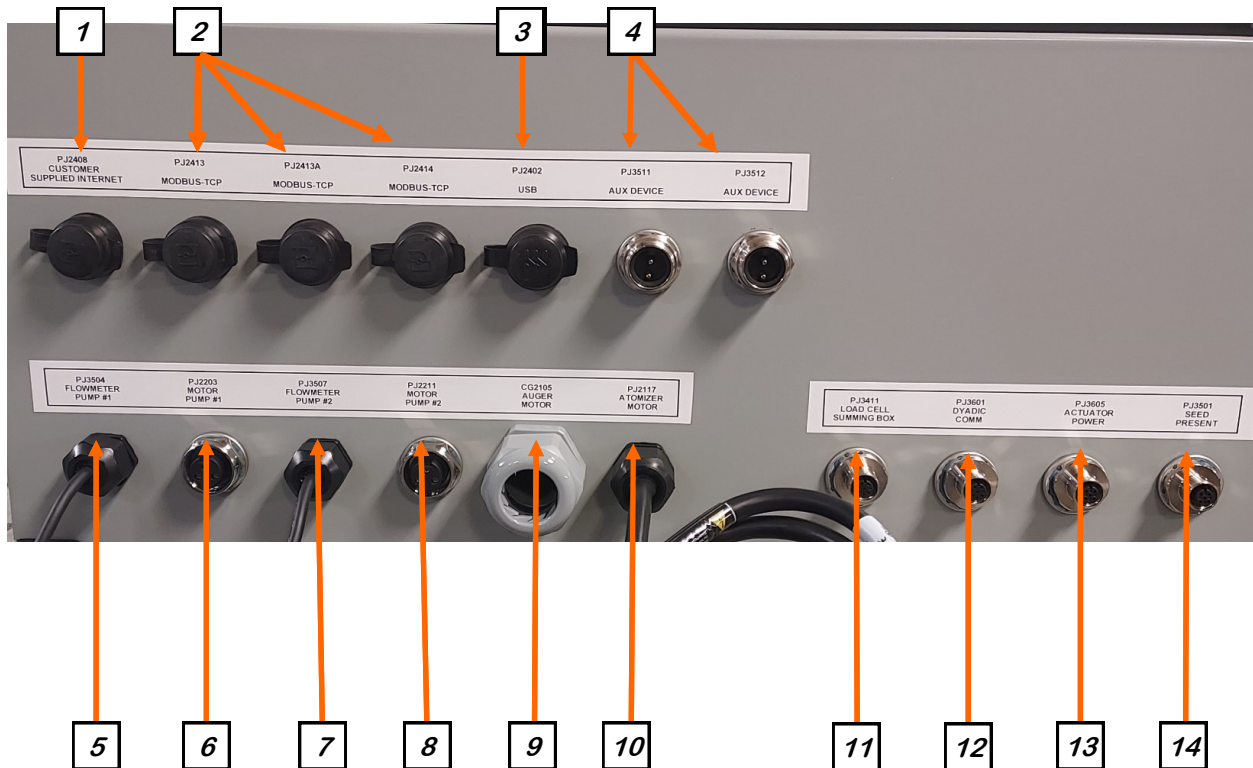

1. To use the U-Connect Mini remote support capabilities; connect an internet connected ethernet cable to the Customer Supplied Internet port.
2. There are three MODBUS TCP Ethernet connectors on the Control Panel. These are used to connect to pump # 3&4, wireless access point for tablet control, printer, and other peripheral devices to connect to the AT500.
3. Use the USB port to plug in a compact flash device. This will be used to export reports from the system, and other import/export features
4. Connect the cable from any additional individually controlled pump stands to either of the two wire connectors PJ2111 Aux Device or PJ2112 Aux Device.
5. Connect the cable from Flowmeter Pump #1 to the Pump #1 Flowmeters connector. The number one pump is the one closest to the control panel. This is factory connected.
6. Connect the cable from the Pump #1 Motor to the Motor Pump #1 connector. The number one pump is the one closest to the control panel. This is factory connected.
7. Connect the cable from Flowmeter Pump #2 to the Pump #2 Flowmeter connector. The number two pump is the one farthest from the control panel. This is factory connected.

MAIN CONTROL PANEL CONNECTIONS

8. Connect the cable from the Pump #2 Motor to the Motor Pump #2 connector. The number two pump is the one farthest from the control panel. This is factory connected.
9. Auger motor power cord. This is factory connected.
10. Connect the Atomizer Motor cable from treater panel to the atomizer motor. This is factory connected.
11. Connect the cable from the load cell junction box to the Load Cell Summing Box connector. This is factory connected.
12. Connect the 8 pin communication cable from the dyadic actuator to the Actuator Comm connector. This is factory connected.
13. Connect the 4 pin power cable from the dyadic actuator to the Dyadic Power connector. This is factory connected.
14. Connect the cable from proximity sensor mounted above the Loss In Weight actuator gate to the Seed Present connector. This is factory connected.

MECHANICAL OPERATION SECTION C

AT500H AUTOMATED TREATER OVERVIEW

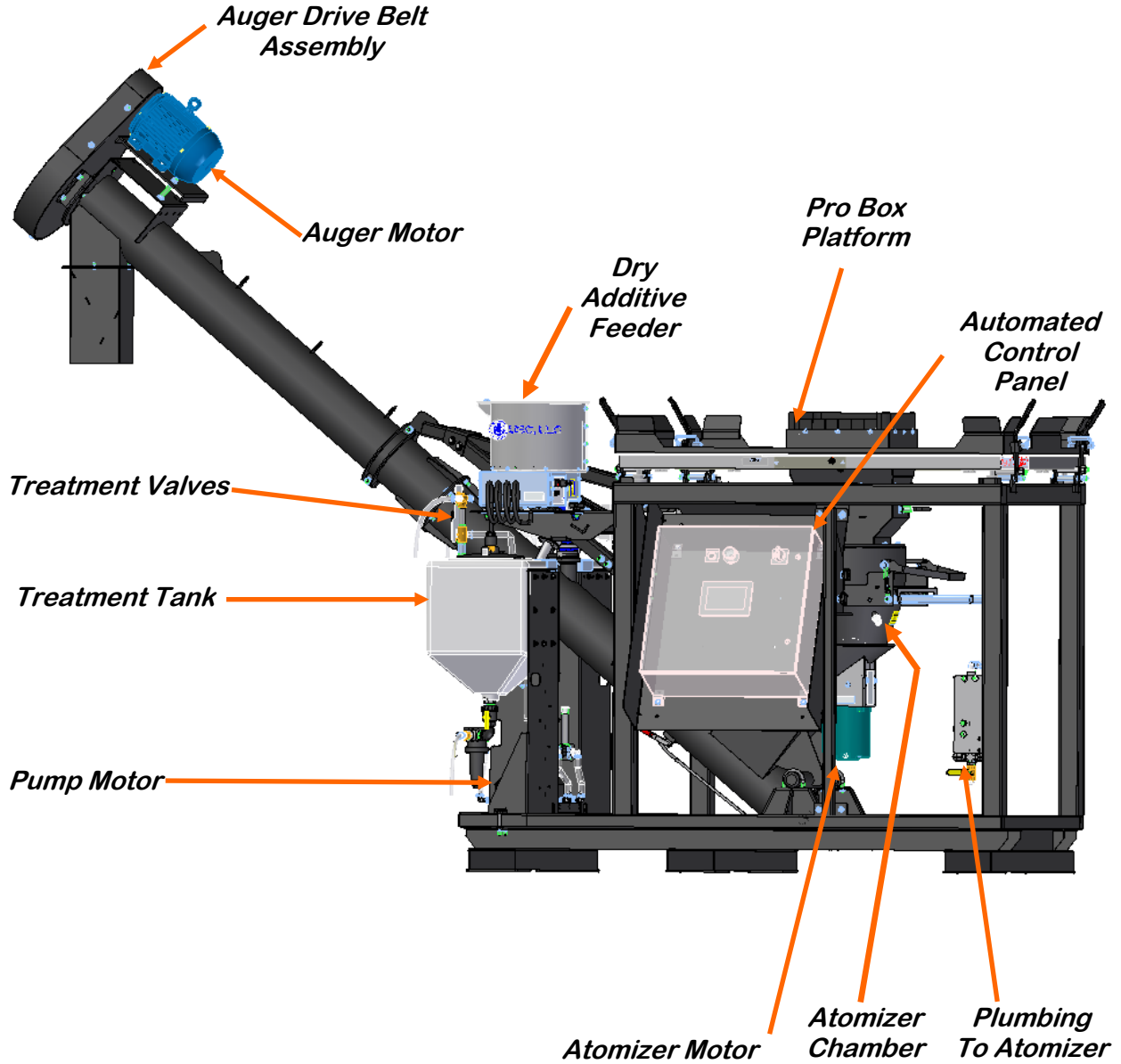

LOSS IN WEIGHT SLIDE GATE AND ATOMIZER CHAMBER

The atomizer chamber consists of a patented design which disperses treatment evenly to each seed. A motor drives the atomizer head at approximately 1725 RPM's. As treatment is being pumped into the atomizer chamber, it drops into the atomizer head. The centrifugal force of the spinning head forces the treatment to be sprayed out through a screen covering in all 360 degrees. Meanwhile, seed flows down out of the box, through the seed gate and down on top of the distribution cone which disperses the seed down around the atomizer head. The atomizer can be easily accessed for cleaning and maintenance by pulling down on the quick release handle and sliding the atomizer away from the treater body (see page 53).

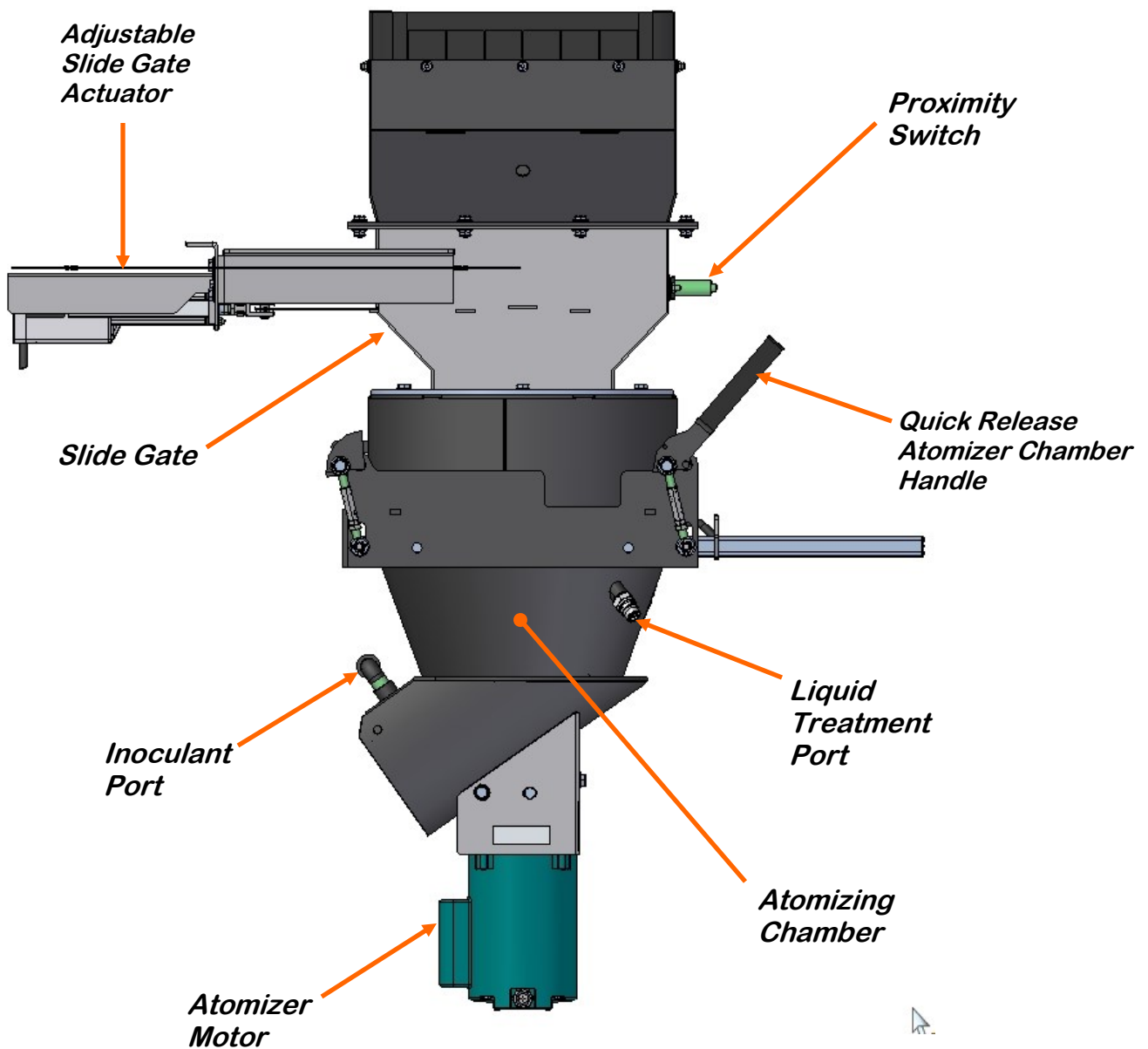

PERISTALTIC PUMP HEAD AND MOTOR

The pump stand utilizes a variable speed pump motor and special noprrene pump tubing for liquid metering. Each pump comes equipped with 1 peristaltic pump head. Liquid will only come into contact with the inside diameter of the pump tubing and not the pump. This allows for easy cleanup and less maintenance of the pump.

To open the pump head, rotate the lever to the left. Place the pump tubing inside the pump head so it fits inside the notches and above the rollers (bottom, left). Rotate the lever back to the right and close the pump head, clamping the hose inside the head (bottom, right). Wear or fatiguing of the tubing within the pump head due to compression is normal. When tubing becomes worn or chemical rates begin to slow down, open the pump head and move the tubing to a different position. If the entire piece of tubing becomes worn, simply replace with a new section. When not using the pump stand for several days or when storing, open the pump head and remove the tubing to prevent any extra compression.



Pump Head Open

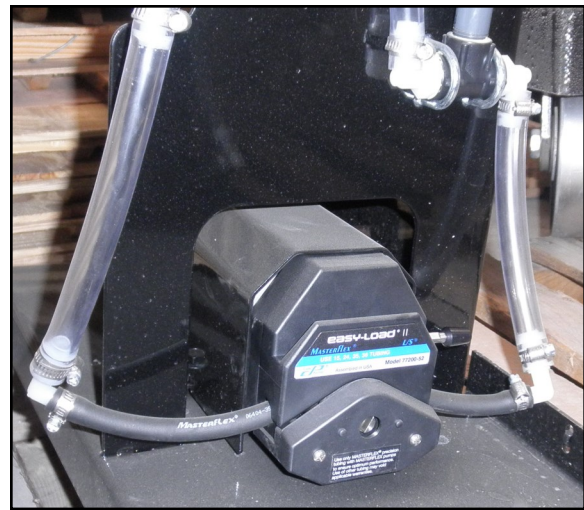

Pump Head Closed

SEED TREATMENT VALVES

SEED TREATMENT VALVES (Left Pump Stand): When the handle of the bottom valve is in the horizontal position the liquid recirculates back into the top of the tank. In the vertical position it sends the liquid up to the top valve.

When the handle of the top valve is in the horizontal position the liquid is directed to the short, unconnected tube so the liquid may flow into a measuring container for pump calibration purposes. In the vertical position it sends the liquid to the treater.

SEED TREATMENT VALVES (Right Pump Stand): When the handle of the bottom valve is in the vertical position the liquid recirculates back into the top of the tank. In the horizontal position it sends the liquid up to the top valve.

When the handle of the top valve is in the horizontal position the liquid is directed to the short, unconnected tube so the liquid may flow into a measuring container for pump calibration purposes. In the vertical position it sends the liquid to the treater.



Left Tank Source Valve



Right Tank Source Valve

FLOW METERS

The pump stands are equipped with volumetric flow meters. A flow meter is used to perform real - time chemical flow adjustments and monitoring without the operator having to handle the chemical. The flow meter reading will be displayed on the HMI touch screen and can be set to read in oz / min or ml / min.



Volumetric Flow Meter

Proper calibration of the liquid system is critical to achieve a proper granular / chemical mixture. For information on pump calibration and flow meter calibration to determine liquid flow rate, see the Calibration and Operation section.

Emptying the remaining liquid may be done by using the reverse function on the control panel. This will pump liquid back into the mix tank. Then drain the remaining liquid into a suitable container. Clean water should be pumped through the calibration tube and mix tank when finished.



WARNING Always dispose of chemical or diluted chemical according to your local, state, and federal regulations.



Only you, the operator, can determine the length of time required to completely rinse all chemical residue from the tank and plumbing system.

SECTION
D

ELECTRICAL OPERATION



HIGH VOLTAGE ~ Always disconnect the power source before working on or near the control panel or lead wires.



HIGH VOLTAGE ~ Use insulated tools when making adjustments while the controls are under power.



AUTHORIZED PERSONNEL only shall work on the control panel. Never allow anyone who has not read and familiarized themselves with the owner's manual to open or work on the control panels.



USC recommends the use of a surge protection device with a minimum rating of 400 Joules for all automated main control panels.

AT500H TREATER

MAIN SCREEN

This screen informs the operator of the status of all system motors and electrical devices and allows for control / adjustment of system operations.

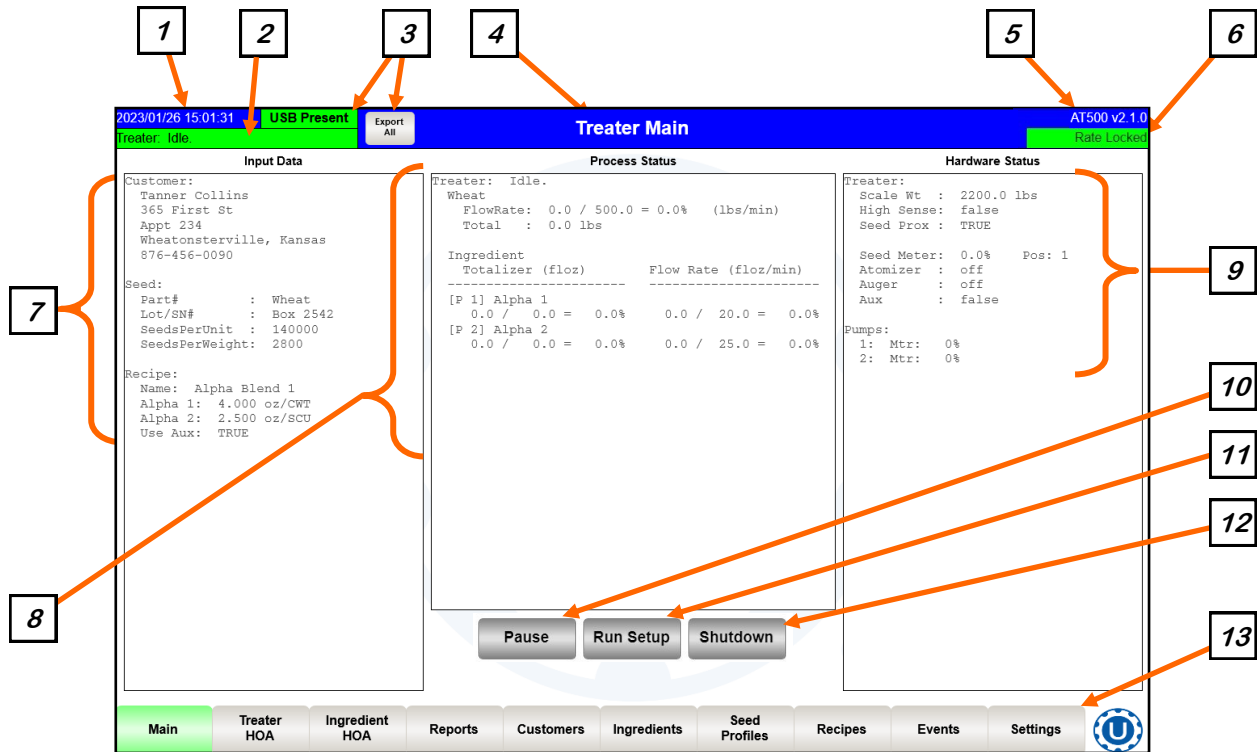

1. DATE & TIME: The date and time are displayed in the upper left corner of the screen. If pressed, a popup will appear and allow modifications to the Date and Time of the system. Select the top dropdown to set the year, month, and day. Pressing each numeric will allow these values to be manually set. Select the bottom three numeric to set the time. The system is based on a 24 hour clock. When keying in the hour, 2:00 P.M. is 14 hours as in the example below. Press the OK button in the center of the screen to save your entries.

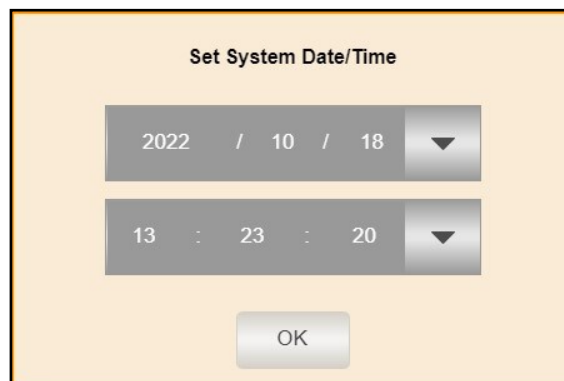

MAIN SCREEN DESCRIPTIONS

2. TREATER STATUS DISPLAY: Displays the current treater status. Here the operator will be able to identify if the treater is in an Emergency Stop state, in an Alarm state, Recipe Not Satisfied, or Idle.

3. USB Status: “USB Present” and an Export All button appear when a USB storage device is present. “Export All” will perform the export function for all user-editable data tables including Events and Reports data (ex. Customers, Seed, Recipe, etc.).

4. SCREEN TITLE DISPLAY: Displays the current screen title.

5. PROGRAM VERSION DISPLAY: Displays the current program release version.

6. RATE LOCK DISPLAY: Displays if the LIW Actuator’s rate is currently locked in during a run if the Rate Lock feature is enabled. If this display is active it is now safe to add product to the scale without affecting the process.

7. INPUT DATA DISPLAY: Displays the configured run information configured within the Run Setup popup. This will display the Customer Information, Seed Information, and Recipe Information.

8. PROCESS DATA DISPLAY: Displays the process data of the current process. During an automated run, this information will update with live statistics.

```
Treater: Running...
Wheat
FlowRate: 353.0 / 420.0 = 84.0% (lbs/min)
Total : 483.3 lbs
```

The first section of the Process Data displays the Treater Status on the first line. The second line lists the current Seed Profile Name. The Flow Rate is displays as Current / Target = % Accuracy. In this example the Current Flow Rate is 353 lbs/min while the Target Flow Rate is 420 lbs/min. The last line in the first section displays the Seed Totalizer.

```
Ingredient
Totalizer (floz)      Flow Rate (floz/min)
-----
[P 1] Alpha 1
23.8 / 19.3 = 123.3%  17.3 / 16.8 = 103.3%
[P 2] Alpha 2
14.4 / 12.0 = 119.3%  10.5 / 10.5 = 99.9%
```

The second section of the Process Data displays run data on the Ingredient application process. The list of ingredients depends on the Recipe that has been selected. If the ingredient listed is assigned to a pump, the pump number will be displayed within the brackets. Following the brackets the Ingredient Name is displayed. Below the Ingredient Name on the left, the Ingredient Totalizer data is displayed as Current / Target = % Accuracy. On the right side the Flow Rate is also displayed as Current / Target = % Accuracy.

MAIN SCREEN DESCRIPTIONS

9. HARDWARE STATUS DISPLAY: Displays current status of all configured hardware. Listed are devices such as the Scale Weight, Inlet Conveyor (if used), High Level Proximity Sensor, Seed Present Proximity Sensor, Seed Metering, Atomizer, Auger, Auxiliary Controls, Pump Controls.

10. PAUSE BUTTON: During an automated run, this button will appear. Pressing this button will pause the automated run and stop all devices in the Auto state. While Paused, this button's label will update to say 'Resume'. Pressing Resume will start the automated process back up.

11. RUN SETUP: When pressed, this button will present the Run Settings popup. Here an automated run can be configured and setup to meet the operators needs.

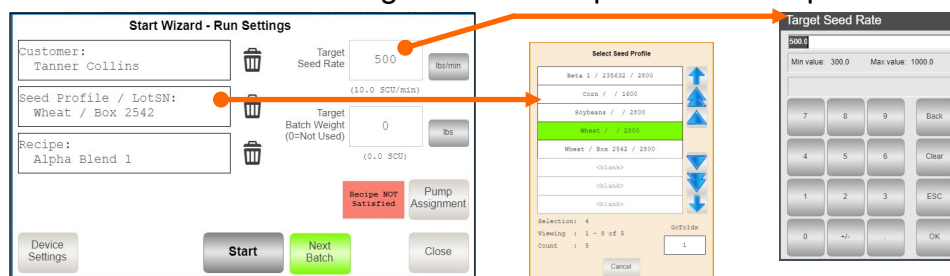

Pressing the Customer, Seed Profile, or Recipe fields will bring up a selection popup allowing the operator to select a previously configured profile. Pressing the Trash icon will clear the currently selected profile from selection.

Pressing either the Target Seed Rate or the Target Batch Weight will cause a Numeric keypad to appear allowing the values to be modified. To the right of the Target Seed Rate or the Target Batch Weight is a button that when pressed will allow the measured units to swap between weight and SCUs. Setting the Target Batch Weight to 0 will disable batch targeting for this run. Target Batch Weight will only be presented if this feature is enabled on this system.

Pressing the Pump Assignment button will allow the Pump Ingredient Assignments popup to appear. If the needs of the currently selected Recipes are not met, a message will appear in the Treater Status bar and to the left of the Pump Assignment button. This can be corrected by selecting a different Recipe or assigning the needed Ingredients to the pumps. Pressing the box under the Ingredient Part # will present a popup allowing the selection of ingredients that can be assigned to respective pump in order to satisfy the selected recipe. Pressing the Trash icon to the left will clear the current selection. The Calibration Ratio for the ingredient can be manually adjusted from the Pump Ingredient Assignment popup as well. Pressing the Close button will close the current popup.

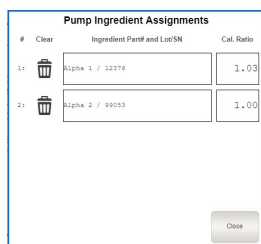

MAIN SCREEN DESCRIPTIONS

11. RUN SETUP (Continued): Pressing the Device Settings will allow the Device Settings to be viewed and edited. Here, Start Delays and Stop Delays can be adjusted to meet the needs of the automated run.

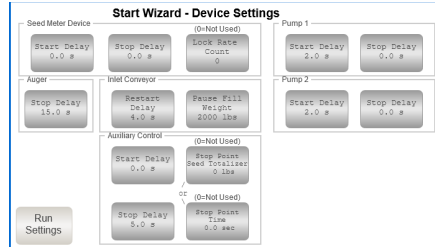

Under the Seed Meter Device section the Lock Rate Count can be adjusted to lock in the Seed Metering Flow Rate after the specified number of moves. If this value is 0, the Flow Rate will not lock and will allow continuous adjustments to achieve the Target Flow Rate requested. The Inlet Conveyor section will only be present if the option is enabled on this system. The Restart Delay will delay the restart of the Inlet Conveyor after an inlet pause event has occurred. The Pause Fill Weight will pause the Inlet Conveyor when the scale weight reaches this weight. The Auxiliary Control “Stop Point” options can be used to turn off the auxiliary output after a specified amount of seed totalizing has occurred or after a specified amount of run time. A value of zero disables these features. If both are enabled, the first one to be achieved will cause the auxiliary output to turn off. Pressing the Run Settings will return the operator to the Run Settings page.

Pressing the Start button on the Run Settings popup will begin an automated run. If the button is faded, it is disabled and will not start the run. Alarms and the Recipe must be satisfied to start a run.

If Target Batch Mode is enabled and the target weight has been met, the system will turn off the pumps and the seed metering. To continue the run, the operator must press the Next Batch button to allow the system to target the Target Batch Weight again.

Pressing the Close button will close the Run Settings popup without starting an automated run.

12. SHUTDOWN BUTTON: Pressing this button will begin the shutdown process which will shutdown each device, processing each device’s shutdown time, and will then create a Report of the automated run. This button will be present during an automated run. If the automated run is paused, this buttons label will read ‘Terminate’. Pressing it at this point will Terminate the run without processing device shutdown times. A Report will still be generated in this event.

13. NAVIGATION BAR: Pressing any of the buttons on this bar will navigate you to another screen. A green button will indicate the currently active screen.

Treater H-O-A (HAND-OFF-AUTO) SCREEN



These H-O-A buttons force the selected component to be energized (HAND), de-energized (OFF), or automatically energized by the normal logic sequence (AUTO). The HAND function will cause the component to operate independent of whatever else the system is trying to do automatically. These functions should not normally be used if the automated sequencing is active. **Be sure to understand the impact of energizing or de-energizing a component with the settings before using them. These commands are not a substitute for Lockout/Tagout procedures when working on or near this machine. Use proper lockout/tagout procedures to disable the equipment before servicing it.**

Hand-Off-Auto controls are provided for most of the automated devices in the system, and are accessed on this screen. All treater, conveyor and pump stand motors are controlled here.

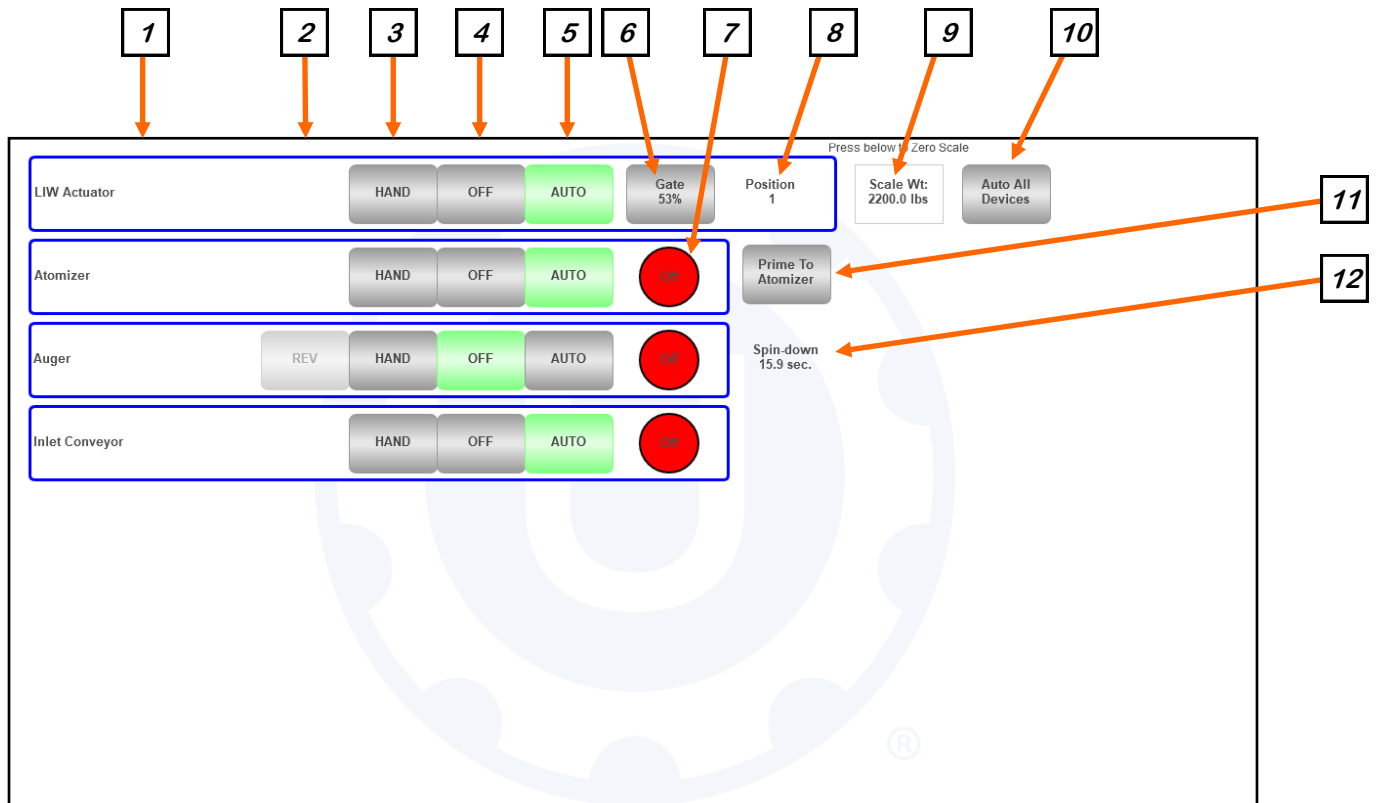

AT500H TREATER

Ingredient H-O-A (HAND-OFF-AUTO) SCREEN

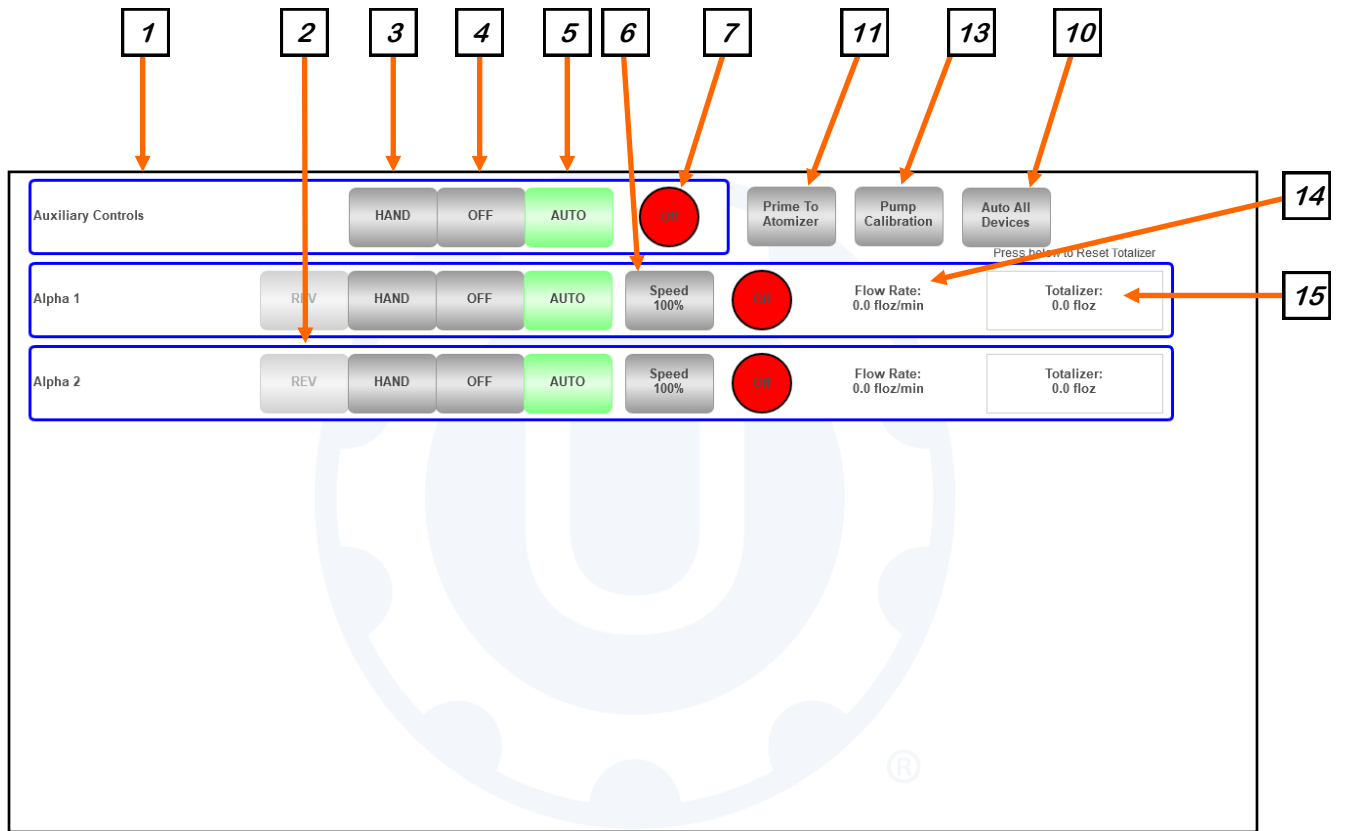

H-O-A (HAND-OFF-AUTO) SCREEN

- 1. DEVICE NAME DISPLAY:** Displays the device name.
- 2. REVERSE BUTTON:** Pressing this button will put the corresponding device in the Reverse state. In the Reverse state the motor will energize and run opposite of the standard direction. The Reverse button is disabled unless the device is in the Off state.
- 3. HAND BUTTON:** Pressing this button will put the corresponding device in the Hand state. In the Hand state, the motor will energize and run in the standard direction. The Hand button is disabled while in the Reverse state.
- 4. OFF BUTTON:** Pressing this button will put the corresponding device in the Off state. In the Off state, the motor will not be energized.
- 5. AUTO BUTTON:** Pressing this button will put the corresponding device in the Auto state. In the Auto state the motor will be controlled by the automated process, energizing during a run or during calibration.
- 6. HAND SPEED CONTROL:** Pressing this button will allow modification to the speed while in the Hand state for the corresponding device.
- 7. DEVICE RUN INDICATOR:** Displays a run indicator for the corresponding device. While the device is requested to be off, the indicator will be red. While the device is requested to be on, the indicator will be green.
- 8. LIW ACTUATOR POSITION DISPLAY:** Displays the current raw position reported from the LIW Actuator.
- 9. SCALE WEIGHT DISPLAY:** Displays the live scale weight. Pressing this display while not in a run will reset the scale to 0.
- 10. AUTO ALL DEVICES BUTTON:** Pressing this button will cause all devices except the Auxiliary controls and the Pump controls to be placed in the Auto state. The Auxiliary controls and the Pump controls will move when leaving the HOA Screen to Auto or Off depending on the needs of the currently selected Recipe.
- 11. PRIME TO ATOMIZER BUTTON:** Holding this button will activate the Atomizer, Auxiliary, and Pump devices that are in Auto. This can be used to prime fluid to the Atomizer chamber before a run.
- 12. AUGER SPIN-DOWN:** This count-down timer will appear when the auger is told to turn off. Once it has completed, it will disappear and the HOA control will allow you to reverse the direction of the auger. If you wish to turn it back on in the direction it was already going, you can do so immediately without waiting on the timer.

H-O-A (HAND-OFF-AUTO) SCREEN

13. PUMP CALIBRATION BUTTON: Pressing this button will present the Pump Calibration popup. Here a pump can be calibrated to the Ingredient that is assigned to it.

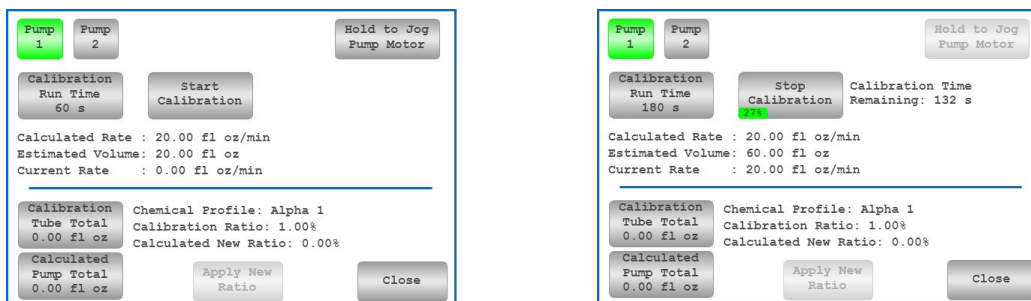

Pressing the Pump 1 button or Pump 2 button will select that pump for calibration. Pressing the Calibration Run Time will present a numeric keypad that will allow the operator to set the run time for the calibration process. It is recommended to run longer calibrations to provide the best results. Pressing the Start Calibration button will begin the calibration process for that pump. While the calibration process is processing, the label will update to 'Stop Calibration' and display a load bar to indicate how much time remains in the process. There will also be a display appear during calibration that displays the remaining time in seconds. Pressing Stop Calibration will stop the currently selected pump's calibration. The Start Calibration button is disabled if no valid Ingredient has been assigned to the selected pump. The Calculated Rate displays the pump rate that has been calculated based on the Target Treating Rate and the currently selected Recipe's Application Rate for that Ingredient. The Estimated Volume displays the estimated volume based on the Calculated Rate and the Calibration Run Time. The Current Rate displays the pumps flow rate while in a calibration run. Holding the Hold to Jog Pump Motor button will cause the selected pump to engage if it is in the Auto state. After a calibration run, the Calibration Tube Total can be adjusted to meet what actually was pumped during the calibration. The Calculated Pump Total will be populated with what the calibration process believed it pumped. This can be modified if needed. The Ingredient Profile displays the Ingredient that is assigned to the currently selected pump. The Calibration Ratio displays the current calibration ratio for the Ingredient. The Calculated New Ratio displays newly calculated calibration ratio based on the ratio of the Calibration Tube Total against the Calculated Pump Total. Pressing the Apply New Ratio button will update the Calibration Ratio from the Calculated New Ratio. Pressing Close will close the Pump Calibration popup.

14. PUMP FLOW RATE DISPLAY: Displays the current pump flow rate.

15. PUMP TOTALIZER DISPLAY: Displays the current pump totalizer. Pressing this display while not in a run will reset the totalizer back to 0.

PROFILE EDIT SCREENS

There are commonalities between each of the profile editing screens. Editing screens include Reports, Customers, Ingredients, Seed Profiles, and Recipes.

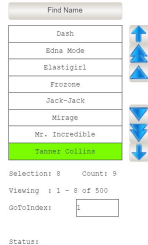

Each profile screen has a Navigation pane shown on the left. Pressing Find Name will bring up a keyboard allow the operator to search for a record. Below the Find Name, selecting any of the previously set up records will bring up the profile on the right for editing. You can use the blue arrows for scrolling to view other profiles in the Navigation pane. Below the Navigation pane are statistics for the profile lists, showing Selection number, total Count of records, and bounds of what the Navigation pane is currently displaying. Pressing Go To Index will allow the operator to immediately navigate to the Record ID that is typed in.



Pressing New will present a blank record for editing purposes. Pressing Save will save any changes that have been made to the currently displayed record. If the Save button is red, changes have been detected and have yet to be saved. If the operator does not want to save the changes, a different record can be selected and the changes will not be saved. Pressing Clear will clear the data from the currently selected record. Save will need to be pressed to confirm the request. Pressing the Import button will delete and import the entire record list from a connected USB device. Pressing the Export button will export the entire record list to a connected USB device. The Import and the Export buttons are disabled if a USB device is not connected. USB Connected Status can be found to the right of the Date and Time display at the top of the screen. Pressing the Delete Database button will open a prompt to confirm to the user whether they want to delete the entire record list.

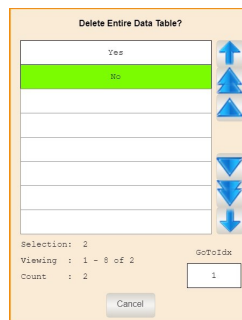

AT500H TREATER

REPORTS

After the run is complete and all of the seed has been run through the auger, press the shutdown button. Once a run is finished the data is saved automatically in the reports file. The operator may access these records from the Reports screen. Press the Reports button and you will be viewing the last recorded run.

Find Name	Start Time: 2022/08/31 17:50:09	Seed: Wheat
2022/08/31 17:50:09	End Time: 2022/08/31 17:51:32	Lot/SN: Box 2542
2022/08/31 17:55:25	System Alarmed: No	Seeds/Unit: 140000
2022/08/31 18:00:42	System Paused: No	Seeds/Weight: 2800
2022/08/31 18:01:31	Customer: Mr. Incredible	Calibration: 1.02
2022/08/31 18:29:55	Seed Total: 242 lbs / 4.8 SCU	Notes:
2022/08/31 18:35:29	Flow Rate /min: 500 lbs / 10.0 SCU	
2022/09/14 10:05:11	Flow Time: 35.1 seconds	
<blank>	Recipe: Lotsa Water	Aux Used: Yes
Selection: 32 Count: 38	Ingredient Name Lot/SN Qty (fl oz) Accuracy (%)	
Viewing : 32 - 39 of 10000	Water 4.9 101.0%	
GoToIndex: <input type="text" value="32"/>	Water2 10.7 100.3%	
Status:	<input type="button" value="Print"/> <input type="button" value="Save"/>	<input type="button" value="Export"/> <input type="button" value="Delete Database"/>

The top left section of the Reports screen details general run statistics as well as Customer information. Below that, Seed amounts are displayed listing the Seed Totals, the Flow Rate per minute, and the Seed Flow Time. At the top right, specific Seed Details are listed from the run. Below that, a Notes field is available to record run specific details. At the bottom half of the Reports page Ingredient Usage is detailed and whether the Auxiliary controls were used during the run.

If a USC 8.5"x11" printer is connected to the system, the Print button can be pressed to print the currently selected report.

PROFILE EDITING SCREENS

CUSTOMERS: Pressing Customers from the Navigation Bar will present the Customer screen. Select a Customer on the Profile Navigation Pane at the left to edit an existing customer. To create a new customer press the New button and edit the needed fields. Press the Save button to save changes.

The screenshot shows a web application interface for editing customer profiles. On the left, there is a 'Find Name' search bar above a list of customer names: Dash, Edna Mode, Elastigirl, Frozone, Jack-Jack, Mirage, Mr. Incredible, and Tanner Collins. The 'Tanner Collins' entry is highlighted in green. To the right of the list are vertical navigation arrows. The main area displays the profile for 'Tanner Collins' with the following details:

Name:	Tanner Collins
Address:	365 First St
Address:	Appt 234
City:	Wheatonsterville
State:	Kansas
Zip:	55668
Phone:	876-456-0090

Below the profile, there are statistics: 'Selection: 8' and 'Count: 9'. A 'Viewing' indicator shows '1 - 8 of 500'. A 'GoToIndex:' field contains the number '1'. At the bottom, there is a 'status:' label and a toolbar with buttons: 'New', 'Save' (highlighted in green), 'Clear', 'Import', 'Export', and 'Delete Database'.

PROFILE EDITING SCREENS

INGREDIENTS: Pressing Ingredients from the Navigation Bar will present the Ingredients screen. Select an ingredient on the Profile Navigation Pane at the left to edit an existing ingredient. To create a new ingredient press the New button and edit the needed fields. Press the Save button to save changes.

Find Name	
Alpha 1 / 12376	↑
Alpha 1 / 76533	↑↑
Alpha 2 / 99053	↑↑↑
Chemical 1	↓
Chemical 2	↓↓
Chemical 3	↓↓↓
Chemical 4	↓↓↓↓
Pizza2	↓↓↓↓↓

Name/Part#:

Lot/SN:

Location:

Selection: 1 Count: 13

Viewing : 1 - 8 of 10000

GoToIndex:

Status:

PROFILE EDITING SCREENS

SEED PROFILES: Pressing Seed Profiles from the Navigation Bar will present the Seed Profiles screen. Select a seed profile on the Profile Navigation Pane at the left to edit an existing seed profile. To create a new seed profile press the New button and edit the needed fields. Press the Save button to save changes.

Find Name	
Beta 1 / 235632	↑
Corn	↑
Soybeans	↑
Wheat	↓
Wheat / Box 2542	↓
<blank>	↓
<blank>	↓
<blank>	↓

Name/Part#:	Beta 1
Lot/SN:	235632
SeedsPerUnit:	140000
SeedsPerWeight:	2800
Calib. Ratio:	1.00
Calib. Speed:	500
MinGatePos:	1100

Selection: 1 Count: 5
Viewing : 1 - 8 of 500
GoToIndex:

Status:

PROFILE EDITING SCREENS

RECIPES: Pressing Recipes from the Navigation Bar will present the Recipes screen. Select a recipe on the Profile Navigation Pane at the left to edit an existing ingredient. To create a new recipe press the New button and edit the needed fields. Press the Save button to save changes.

Pressing under the Ingredient header will present a selection to select a previously created ingredient.

The screenshot shows the 'Profile Editing' interface for a recipe named 'Alpha Blend 1'. On the left, a list of ingredients is shown with 'Alpha Blend 1' selected. The main area contains fields for 'Name' (Alpha Blend 1) and 'Aux Used' (Yes). Below this is a table of ingredients with columns for 'Ingredient', 'App. Rate', and 'App. UoM'. The table lists six ingredients, with the first two being 'Alpha 1' and 'Alpha 2'. At the bottom, there are buttons for 'New', 'Save', 'Clear', 'Import', 'Export', and 'Delete Database'.

Ingredient	App. Rate	App. UoM
1: Alpha 1	4.000	oz/CWT
2: Alpha 2	2.500	oz/CWT
3:	0.000	oz/CWT
4:	0.000	oz/CWT
5:	0.000	oz/CWT
6:	0.000	oz/CWT

The screenshot shows a 'Select Ingredient Part Number' dialog box. It features a list of ingredients with 'Alpha 1' selected. The list includes 'Alpha 1', 'Alpha 2', 'Chemical 1', 'Chemical 2', 'Chemical 3', 'Chemical 4', 'Pizzaz', and 'Powder'. Below the list, there are fields for 'Selection: 1', 'Viewing: 1 - 8 of 12', and 'Count: 12'. A 'GoToIdx' field contains the value '1'. A 'Cancel' button is at the bottom.

AT500H TREATER
EVENTS SCREEN

The Events screen shows a listing of system alarms and messages both current and reset. It also allows you to silence an active alarm and clear non active entries.

The screenshot shows the Events screen interface. At the top, there are four buttons: 'Alarms' (highlighted in green), 'Messages', 'View Non-Archived', and 'View All' (highlighted in green). To the right are 'Export' and 'Delete Database' buttons. Below these is a table with 8 rows of data. To the right of the table are vertical navigation arrows (up, down, and a double arrow). Below the table, there is a 'Selection: 1' and 'Count: 702' label. Further down, it shows 'Viewing : 1 - 8 of 702', 'GoToIndex: 1' (with an input field), 'Active Alarms : 0', 'Active Messages: 0', and 'Total Records : 727 of 10000'. At the bottom right, there are three buttons: 'Silence', 'Reset', and 'Archive'. The 'Status:' label is at the bottom left.

2022/10/14 17:39:34	Archived	SLIW.2	Seed Actuator is reporting a device issue. Check E-Stop and actuator cable connections. (0,0)
2022/10/14 17:39:29	Archived	IO.1	Failed to establish communications with the Scale Indicator. Check functionality and connections of the scale indicator.
2022/10/14 17:34:23	Archived	SLIW.2	Seed Actuator is reporting a device issue. Check E-Stop and actuator cable connections. (0,0)
2022/10/14 17:34:18	Archived	IO.1	Failed to establish communications with the Scale Indicator. Check functionality and connections of the scale indicator.
2022/10/14 17:25:48	Archived	SLIW.2	Seed Actuator is reporting a device issue. Check E-Stop and actuator cable connections. (0,0)
2022/10/14 17:25:44	Archived	IO.1	Failed to establish communications with the Scale Indicator. Check functionality and connections of the scale indicator.
2022/10/14 10:02:50	Archived	SLIW.2	Seed Actuator is reporting a device issue. Check E-Stop and actuator cable connections. (0,0)
2022/10/14 10:02:45	Archived	IO.1	Failed to establish communications with the Scale Indicator. Check functionality and connections of the scale indicator.

Selection: 1 Count: 702

Viewing : 1 - 8 of 702 Active Alarms : 0

GoToIndex: Active Messages: 0

Total Records : 727 of 10000

Status:

To view the Alarms, the operator can press the Alarms in the top left of the screen. To view the Messages, the operator can press the Messages in the top left of the screen. To view only current Alarms or Messages, press the View Non-Archived button. To view all records the View All button can be pressed. At the bottom of the page the current count of Active Alarms and Active Messages can be viewed. Silence can be pressed to silence any active events, keeping them active but not triggering again. Pressing Reset will attempt to clear all active events. If the event conditions are still active, the event will trigger again shortly. Pressing Archive will clear any Acknowledged events from the list. To view these archived events again, View All can be pressed.

CALIBRATION & OPERATION SECTION E

LOAD CELL CALIBRATION



ELECTROCUTION HAZARD

Extra caution must be exercised when working inside the control panel when it is powered.

DANGEROUS VOLTAGES ARE PRESENT

The load cell calibration needs to be checked periodically, especially after moving the AT500H. Use the steps below for proper load cell calibration.

1. Ensure the machine is placed on level ground, scale transport levers (x4) are in the “down” position, and that the 4 feet from the scale are resting on the AT500H frame in a non-binding fashion.

NOTICE

Ensure transport levers are placed in the “up” position prior to moving the AT500H.

2. Place a known weight (minimum 100 lbs. recommended) distributed evenly on the platform scale.
3. Go to the main screen on the control panel. The “Scale Wt.” on the main screen will show 100 lbs.
4. If the screen shows the correct weight, remove the weights and store. If the screen does not show the correct weight, go to step 5 and re-calibrate the load cell.

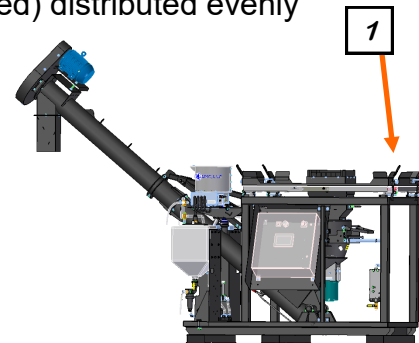

5. Remove weights from the scale. With the control panel powered on, unlock and open the door.
6. Remove the calibration screw on the scale indicator to gain access to the calibration switch.



Face of unit

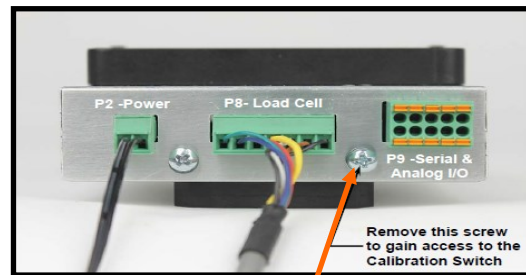

Step 6

Remove this screw to gain access to the Calibration Switch

LOAD CELL CALIBRATION (CONTINUED)

7. Press and hold the calibration switch through the opening from the removal of the screw in the prior step for approximately 2 seconds until the display changes to SEtUP. This is best done with a small tool.(e.g. a 3/32 or 2mm Hex Key Wrench or small screwdriver.)
8. Release the calibration switch to begin setup.
9. Press the F2/▲ key to step until the display shows CAL.
10. With CAL = displayed, press the F3/← key. The display will change to CAL=. Proceed to the CAL= (Perfom Calibration) parameter.
11. With CAL= displayed, press the F3/← key. The display will change to no.
12. Press the F2/▲ key to toggle to YES and then press the F3/← key. The display will change to CAL 1=. Proceed to the CAL 1= parameter.
13. The display will show CAL 1 =. This is the first of two calibration weights. This weight is ZERO (NO LOAD).
14. Press the F3/← key to view the current setting.
15. Press the F3/← key again to set absolute zero.
16. Starting at the left and proceeding right, a series of dashes will appear and then disappear. Then the display will show CAL 2=.
17. This is the second of two calibration weights. This weight is with the recommended 100 lb. test weights or other known weight.
18. Press the F3/← key to view the current setting.
19. Use the F1/◀ and F2/▲ to input the value of the test weights. The display must read 0100.00, (it must match the known weight used for calibration).
20. Place two 50lb. weights on the scale platform, wait for the weight to stabilize on the scale indicator, then press the F3/← key.
21. Starting at the left and proceeding right, a series of dashes will appear and then disappear. Then the display will show F SPAn.
22. The calibration process is now complete. Press F1/◀ until you are returned to the starting screen.
23. Replace the screw removed in step 6.
24. Close and lock the control panel.
25. Remove and store the weights .

SEED FLOW CALIBRATION

1. Press the Run Setup button from the Main screen. Enter in the Target Treating Rate in pounds per minute.

Start Wizard - Run Settings

Customer:
Tanner Collins

Seed Profile / LotSN:
Wheat / Box 2542

Recipe:
Alpha Blend 1

Target Seed Rate: 500 lbs/min
(10.0 SCU/min)

Target Batch Weight (0=Not Used): 0 lbs
(0.0 SCU)

Device Settings Start Pump Assignment Close

2. Press the Seed Profile Screens button. Select the seed profile you wish to calibrate. The seed profile may be edited and the seed actuator gate may be calibrated for that seed. The operator must press Save button before leaving the profile or the changes will be lost and go back to what that profile was previously set to.
3. Setting Minimum Gate Position is adjustable for every profile or may be set the same for every profile. If you have varying seed sizes is it suggested to set them for each profile. This setting indicates the lowest setting that seed will flow at. To set it for a certain seed you will need to have seed available in the zone above the actuator gate. With the gate completely closed, go to the H-O-A screen and set the LIW Actuator Gate % Position setting to 5 % and place the actuator in Hand mode. Then open the gate in small increments until a small but steady stream of seed is flowing out of the actuator. Note the Position reading and place the actuator back in Auto mode of operation.

SEED FLOW CALIBRATION

- (Continued): Return to the Seed Profile screen. Press the Min Gate Position button and use the keypad to enter the position discovered. Press Save to save the updates.

Find Name	
Beta 1 / 235632	↑
Corn	↑↑
Soybeans	↑↑↑
Wheat	↓
Wheat / Box 2542	↓↓
<blank>	↓↓↓
<blank>	↓↓↓↓
<blank>	↓↓↓↓↓

Name/Part#:	Beta 1
Lot/SN:	235632
SeedsPerUnit:	140000
SeedsPerWeight:	2800
Calib. Ratio:	1.00
Calib. Speed:	500
MinGatePos:	1100

Selection: 1 Count: 5

Viewing : 1 - 8 of 500

GoToIndex:

status:

FLOW METER CALIBRATION

Due to the composition of some types of chemicals, additional flow meter calibration may be required. It is recommended that, like other calibration devices, the flow meter is checked regularly and calibrated when needed. When calibrating the flow meter, each chemical must be checked and adjusted for.

1. To begin the calibration process, fill the appropriate tank with the slurry that is going to be used for this calibration.
2. Place the bottom valve in the RECIRCULATE position. Turn the corresponding pump to the Hand position and adjust the flow rate until it reads about 20 percent on the pump control module. Let the system run in recirculation mode for approximately 5 minutes. This will remove any air from the system. Now place the pump in Auto mode.

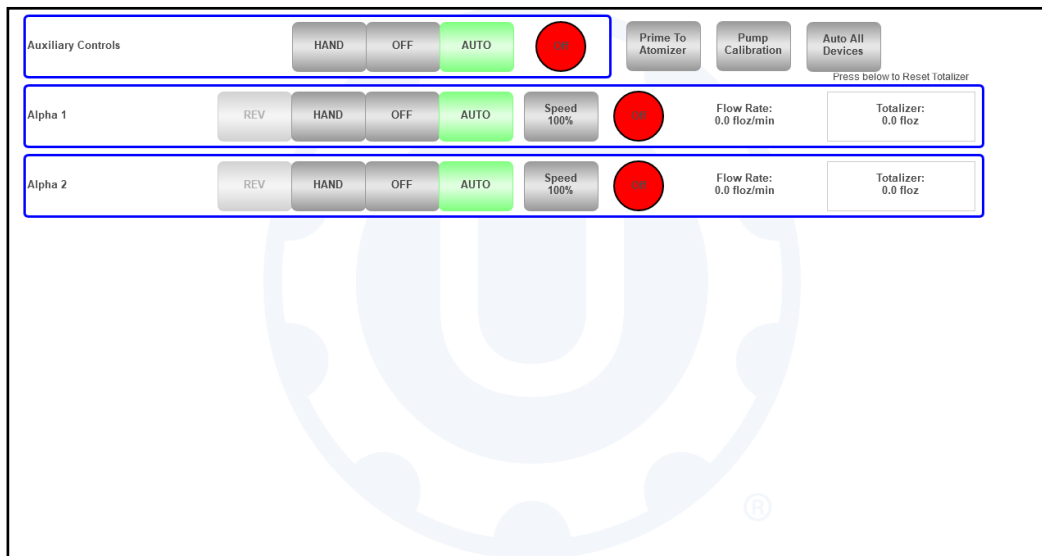

3. Place the bottom valve in the PROCESS / CALIBRATE position and the top valve in the CALIBRATION position.



FLOW METER CALIBRATION

4. From the Treater HOA screen, press the Pump Calibration button. Press the number of the pump you wish to calibrate and a calibration run time for the calibration. The longer the run time the more accurate the calibration. USC recommends a minimum of 60 seconds. Place a measuring receptacle under the calibration fitting discharge tube on the top valve. Hold the Jog Pump Motor and then a second later release it. This will turn the pump on and off quickly. This is done to fill the plumbing between the two valves. When liquid stops coming from the tube, dump what is in the receptacle back into the tank and place it back under the tube.

Press the Start Calibration button to begin the calibration. When the run time has elapsed, the pump will shutoff automatically. If for any reason you need to stop the process, press the Stop Calibration button. If the calibration is stopped before the target time has elapsed, the operator must start the process over again. Enter the calibration receptacle ounces into the Calibration Tube Total box. Enter the flow meter reading into the Calculated Totalizer box. Press the Apply New Ratio button and it will automatically update.

Repeat this process for each pump. The ratio could be slightly different due to hose wear.

The screenshot shows the following interface elements:

- Pump Selection:** Two buttons labeled "Pump 1" and "Pump 2".
- Motor Control:** A button labeled "Hold to Jog Pump Motor".
- Calibration Controls:**
 - "Calibration Run Time" showing 180 s.
 - "Stop Calibration" button with a green progress indicator at 27%.
 - "Calibration Time Remaining: 132 s".
- Flow Data:**
 - Calculated Rate : 20.00 fl oz/min
 - Estimated Volume: 60.00 fl oz
 - Current Rate : 20.00 fl oz/min
- Calibration Summary (below a horizontal line):**
 - Calibration Tube Total: 0.00 fl oz
 - Calculated Pump Total: 0.00 fl oz
 - Chemical Profile: Alpha 1
 - Calibration Ratio: 1.00%
 - Calculated New Ratio: 0.00%
- Action Buttons:** "Apply New Ratio" and "Close".

4. Repeat the process as necessary and for each different chemical slurry used.

AT500H TREATER

TREATING SEED

1. From the HOA screen, press the Auto All Devices button to place the Actuator, Atomizer, and the Auger in Auto. The pumps and auxiliary devices will set themselves to Auto based on the currently selected recipe when leaving the HOA screen.
2. Next, prime the chemical line to the atomizer. Ensure that the valve on each of the chemical attachment ports on the treater are in the correct position. Press and hold the Prime To Atomizer button. The atomizer will turn on and liquid will begin pumping up to the atomizer. When liquid reaches the atomizer release the Prime to Atomizer button. Leave the valve in the process position.

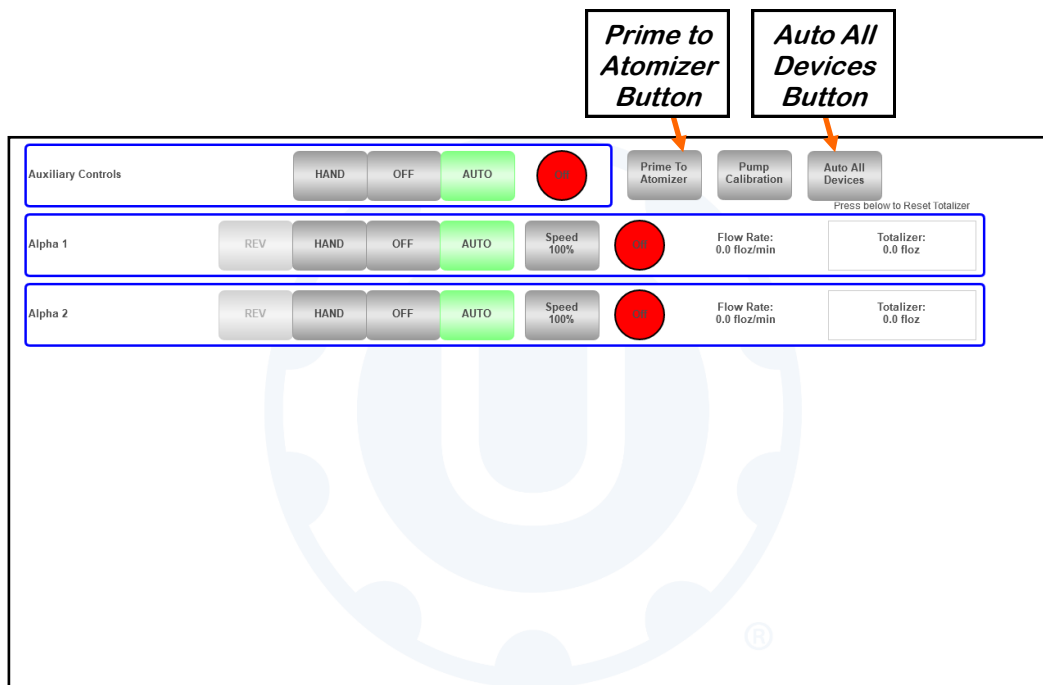

3. Return to the Main screen and press the Run Setup button. Press the profile buttons to change the Customer, Seed Profile, or Recipe fields. Ensure that the Ingredients are assigned to satisfy the selected recipe. Press Pump Assignment to review pump assignments. Press Start to begin the run. The atomizer and auger will turn on. Open the manual gate on the box. When the proximity switch detects seed, a timer will count down the number of seconds the start delay was set for. When that time elapses, the slide gate will open.

TREATING SEED

3. (Continued):

The pump will turn on the same way. Waiting for the pump start delay time defined in the Device Settings. The pump may be set to turn on a second or two before seed is flowing to ensure thorough coating of the first seed out of the box. The operator may open the seed gate first so after pressing the start button, the treating processing will begin immediately after the system is up and running. The message bar in the upper left corner will always show what part of the process the system is currently in.

Start Wizard - Run Settings

Customer: Tanner Collins

Seed Profile / LotSN: Wheat / Box 2542

Recipe: Alpha Blend 1

Target Seed Rate: 500 lbs/min (10.0 SCU/min)

Target Batch Weight (0=Not Used): 0 lbs (0.0 SCU)

Device Settings Start Pump Assignment Close

4. As the seed is being treated, the Main screen will display the box weight and the liquid flow rate. If the system needs to be stopped for a moment, the Pause button may be pressed to temporarily stop the process. When ready to begin again, press the Resume.
5. When all seed has passed through the slide gate it will close and the pumps will turn off. When more seed is fed into the treater, the treating process will continue.
6. After all seed has been treated the pumps will shut off. However, the atomizer, auger will still be running. When there is no more seed discharging from the auger, press the Shutdown button at the bottom of the screen. The auger will continue to run for the number of seconds defined on the Device Settings popup and then stop. Remove the treated box and replace it with an empty one. Place a box of untreated seed on the scale and open the manual gate. Go to the Start Setup screen to continue treating.

AT500H TREATER
TREATING SEED

Input Data	Process Status	Hardware Status
Customer: Tanner Collins 365 First St Appt 234 Wheatonsterville, Kansas 876-456-0090 Seed: Part# : Wheat Lot/SN# : Box 2542 SeedsPerUnit : 140000 SeedsPerWeight: 2800 Recipe: Name: Alpha Blend 1 Alpha 1: 4.000 oz/CWT Alpha 2: 2.500 oz/CWT Use Aux: TRUE	Treater: Running... Batch Achieved. Wheat FlowRate: 0.0 / 500.0 = 0.0% (lbs/min) Total : 500.0 lbs Ingredient Totalizer (floz) Flow Rate (floz/min) ----- [P 1] Alpha 1 23.8 / 20.0 = 119.3% 0.0 / 20.0 = 0.0% [P 2] Alpha 2 14.4 / 12.5 = 115.4% 0.0 / 12.5 = 0.0%	Treater: Inlet Conv: Idle. Scale Wt : 1700.0 lbs High Sense: false Seed Prox : TRUE Seed Meter: 0.0% Pos: 1 Atomizer : Running. Auger : Running. Aux : false Pumps: 1: Mtr: 0% 2: Mtr: 0%

Pause Button

Shutdown Button

SECTION F TROUBLESHOOTING

TROUBLESHOOTING

Below is a table describing the most frequent problems and solutions with the USC AT500H Treater . For further assistance, contact your authorized dealer.

Problem	Possible Cause	Solution
Seed Gate Actuator will not move.	<ol style="list-style-type: none"> 1. Loss in weight seed gate mechanism jammed with debris. 2. One or both of the two connectors linking the actuator to the control panel are not connected. 	<ol style="list-style-type: none"> 1. Clear all debris and make sure mechanism moves freely. 2. Make sure both connectors are properly engaged.
Seed Gate Actuator will not return to the closed position after all seed has emptied from the box.	<ol style="list-style-type: none"> 1. Proximity switch is dirty. 2. Proximity switch is set too sensitive. 3. The system is running in HAND mode. 	<ol style="list-style-type: none"> 1. Clean proximity switch. 2. Adjust the pump proximity switch sensitivity (see page 51). 3. Change to AUTO mode.
Seed Gate Actuator will not move in AUTO.	<ol style="list-style-type: none"> 1. Proximity switch is not staying covered. 2. Proximity switch is not set sensitive enough. 3. HMI screen not set to AUTO. 	<ol style="list-style-type: none"> 1. Make sure proximity switch is staying covered with seed. 2. Adjust pump proximity switch sensitivity by turning the adjustment screw clockwise. 3. Set HMI screen to AUTO.
Seed Gate Actuator will not close completely.	<ol style="list-style-type: none"> 1. Debris may be keeping it from closing completely. 	<ol style="list-style-type: none"> 1. Open the seed gate, remove debris and power cycle the entire system. When the system is turned back on, the gate will automatically close and find it's Home position.
Auger overload keeps tripping	<ol style="list-style-type: none"> 1. Seed flow is too high. 	<ol style="list-style-type: none"> 1. Slow down seed flow.

AT500H TREATER

Problem	Possible Cause	Solution
Flow Meter is fluctuating	<ol style="list-style-type: none"> 1. Pump is sucking air. 2. Restriction in the line. 3. Flow meter is not full of liquid 	<ol style="list-style-type: none"> 1. Check and tighten all hose connections. 1. Check filter to see if gasket is missing or cracked. 2. Clean out filter and lines to check for any debris. 3. The meter will fluctuate if there is nothing pumping and there is some liquid left in the meter. Drain out liquid.
Flow meter won't turn on	<ol style="list-style-type: none"> 1. Improper power going to flow meter. 2. Loose connection. 	<ol style="list-style-type: none"> 1. Check incoming power to flow meter. 2. Check connections inside the control panel and at the flow meter.
Flow Meter is reading too low or too high.	<ol style="list-style-type: none"> 1. Restriction in Flow Meter or in line. 2. Air in treatment. This can cause the flow meter to read lower than calibrating it using a measuring cup. 3. Seed flow has changed. 	<ol style="list-style-type: none"> 1. Flush the flow meter with water or use compressed air and blow air backwards through the meter. 2. Check and tighten all hose connections. 2. Check filter to see if gasket is missing or cracked. 3. Recheck seed flow rate.
Seed flow not consistent.	<ol style="list-style-type: none"> 1. Residue buildup in atomizer. 2. Scale indicator not calibrated. 	<ol style="list-style-type: none"> 1. Clean atomizer chamber. 2. Follow calibration procedure for scale calibration.

AT500H TREATER

Problem	Possible Cause	Solution
Pump will not turn off in AUTO when seed runs out.	<ol style="list-style-type: none"> 1. Proximity switch is dirty. 2. Proximity switch is set too sensitive. 	<ol style="list-style-type: none"> 1. Clean proximity switch 2. Adjust the pump proximity switch sensitivity by turning adjustment screw counter-clockwise.
Pump will not turn on in AUTO	<ol style="list-style-type: none"> 1. Proximity switch is not staying covered. 2. Proximity switch is not sensitive enough. 	<ol style="list-style-type: none"> 1. Make sure proximity switch is staying covered with seed. 2. Adjust pump proximity switch sensitivity by turning the adjustment screw clockwise.
Pump is fluctuating.	<ol style="list-style-type: none"> 1. Restriction in tubing 2. Filter is plugged or missing gasket. 3. Hoses are worn out. 	<ol style="list-style-type: none"> 1. Flush tubing and check filter for any restrictions. 2. Clean filter and check for gasket. 3. Replace hoses.

PROXIMITY SWITCH ADJUSTMENT GUIDE

If a proximity switch is not working properly, this can be caused by wear, dust, or even moisture. The first step is to clean the lens of the proximity switch. If this does not solve the problem, the next step would be to adjust the sensitivity of the proximity switch.

The LED lights indicates the power status. If they are active the device is powered.

The center LED is when the switch closes.

Using the small screwdriver, you can adjust the proximity switch by turning the sensitivity dial of the proximity switch.

- Turn Clockwise to make the proximity switch more sensitive.
- Turn Counterclockwise to make the proximity switch less sensitive.



MAINTENANCE

SECTION G

Proper maintenance of the AT500H Treater is critical for peak performance, reliability and accuracy of this system. The following is a guideline for the type of maintenance and servicing that should be performed on this unit. Your environment and uses may require additional maintenance and service beyond this list to assure a reliable and safe unit. The operator of this unit has ultimate responsibility to identify areas of concern and rectify them before they become a hazard or safety issue. There is no substitute for a trained, alert operator.



Do not put this unit into operation with any questionably maintained parts. Poor performance or a hazard may occur.

GREASING

Use an SAE multipurpose high temperature grease with extreme pressure (EP) performance. Also acceptable is an SAE multipurpose lithium-based grease.

1. Use a Maintenance Checklist to keep record of all scheduled maintenance.
2. Use a hand-held grease gun for all greasing.
3. Wipe grease fitting with a clean cloth before greasing to avoid injecting dirt and grit.
4. Replace and repair broken fittings immediately.



If fittings will not take grease, remove and clean thoroughly. Also clean lubricant passageway. Replace fitting if necessary.

ELECTRICAL PANEL

1. Check and tighten wire connections.
2. Check quick connects on bottom of control panel.
3. Check to see if relays, timers and/or breakers are tripped.
4. Check and set the proximity switches (see page 51).
5. Check quick connects on end of Auxiliary cord.
6. Check and tighten wire connections.
7. Check relay and fuse holder.
8. Check power cords for cuts or frays and ensure ground is present.

AT500H TREATER

ATOMIZER

To access the inside of the atomizer housing, disconnect the motor power cable from the atomizer motor, push up on the quick release handle and slide out the atomizer. After completing maintenance, slide the atomizer back into the operating position, pull down quick release handle to lock it in place and reconnect the motor power cord.

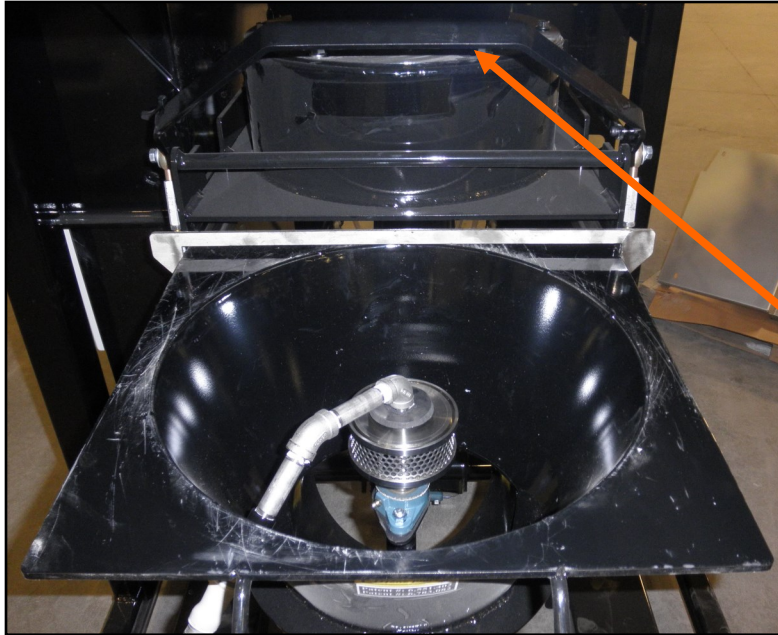

Quick-Release Handle

1. Slide out atomizer housing and grease bearing inside. Bearing needs just one pump of grease every 40 hours of operation (right).
2. Clean any build up inside the housing and the atomizer head. To remove the atomizer head, loosen the set screw located on the bottom of the head.
3. Check for any play in the atomizer shaft.
4. Make sure the atomizer spins smoothly.
5. Ensure the adjustable chute is fitting completely into the auger opening. Adjust if necessary.



Atomizer Head

Bearing

Set Screw

DRIVE BELT TENSION & ALIGNMENT

Power to the auger belt is transmitted through a V-belt. The V-belt drive system must be maintained at the proper belt tension and pulley alignment to obtain the desired performance and life. When maintaining the belt drive system for the electric drive model, follow this procedure:

NOTICE

Turn motor off and unplug power cord or turn off power and lock out the master panel before starting maintenance on drive belt system.

Drive Belt Tension

1. Push on the center of the belt span with a force of approximately 5 to 10 lbs.
2. Follow the belt tensioning specification on page 55 to determine proper belt deflection.
3. Move the motor up, using the adjustment bolts, to set drive belt tension (right).
4. Close and secure guards.

Drive Belt Alignment

1. Lay a straightedge across the pulley faces to check the alignment (right).
2. Use the pulley hub or the motor mounting plate slots to move the pulley to the required position for alignment.
3. Tighten hub bolts to secure pulley on shaft.
4. Check belt tension
5. Close and secure guards.

Drive Belt Replacement

1. Lower motor to its loosest position.
2. Remove old belt and replace with a new one.
3. Raise motor to set the belt tension.
4. Check pulley alignment. Adjust if required.
5. Close and secure guards.



Motor base adjustment



Lay a straightedge across pulley faces

AT500H TREATER

V-Belt tensioning adjustment can be made using a tension meter or other type spring scale using the following procedure. After seating the belts in the groove and adjusting center distance so as to take up the slack in the belts, further increase the tension until only a slight bow on the slack side is apparent while the drive is operating under load. Stop the drive and using the meter, measure the force necessary to depress one of the center belts 1/64 inch for every inch of belt span (see sketch below). For example, a deflection for a 50 inch belt span is 50/64 or 25/32 inch. The amount of force required to deflect the belt should compare with the deflection forces noted in the table below. Also notice for V- Belts that deflection forces vary from the initial RUN - IN values which are greater (reflecting higher run-in tensioning) to the NORMAL values for after the run-in period.

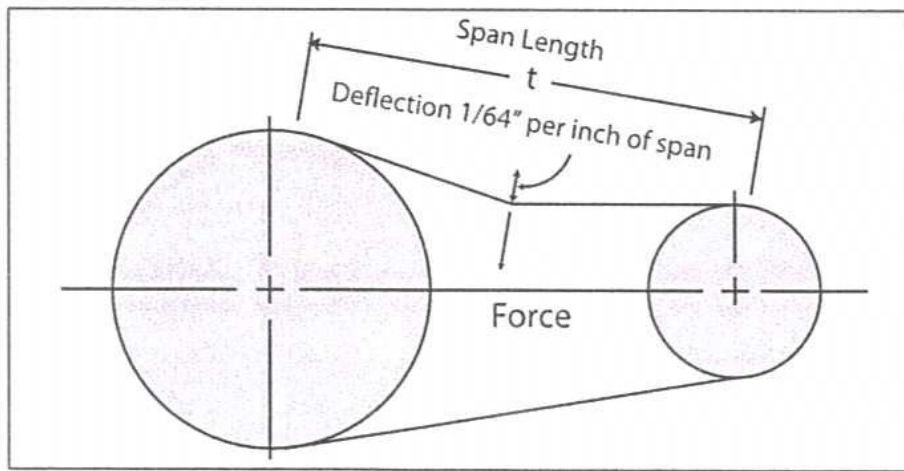

MEASURE THE SPAN LENGTH "T" AS SHOWN IN THE SKETCH ABOVE.

BELT CROSS SECTION	SMALLER PULLEY DIAMETER RANGE (inches)	DEFLECTION FORCE	
		RUN - IN (lbs.)	NORMAL (lbs.)
AX	3.0 - 3.6	4 - 1/8	2 - 3/4
	3.8 - 4.8	5	3 - 1/4
	5.0 - 7.0	6	4
BX	3.4 - 4.2	5 - 1/4	3 - 1/2
	4.4 - 5.2	7 - 1/8	4 - 3/4
	5.4 - 9.4	9	6

PUMPS - PLUMBING - FLOW METER

1. Check pump in forward and reverse.
2. Make sure pump heads open and close smoothly.
3. Inspect tubing for uneven wear. Replace pump tubing often to ensure high flow rates can be achieved.
4. Make certain the inside of the tank is completely drained of chemical. Use clean water to rinse out all chemical residue, then fill the tank with clean water.
5. Disconnect the discharge process lines from the treater static mixer assembly and direct them to a receptacle large enough to hold all of the water from the mix tank.
6. Pump clean water through all areas of the plumbing and flow meter. Opening and closing the valves during this process helps to remove residue from the ball valves.
7. Remove and clean the filter.
8. Open all drain points, valves, and filter to let as much of the water drain as possible.
9. Disconnect power to the flow meter.

NOTICE

Only use the vinegar and water solution mixed in these proportions to clean the flow meter. Use of any other cleaners, especially cleaners containing harsh chemicals may permanently damage the sensors and seals inside the flow meter.

PUMPS - PLUMBING

10. Remove the flow meter from the machine for additional cleaning.

- A. Pre - Mix a solution of 90% water and 10% distilled white vinegar.
- B. Use a size - matched circular brush with soft plastic bristles. Dip the brush in the solution and gently move it up and down in the measuring pipe to avoid damaging the measuring pipe and sensor electrodes.
- C. Re-peat brushing with fresh fluid until measuring pipe is visually clean.
- D. Flush the flow meter inside and out with clean water to remove any of the cleaning solution residue.



STORAGE

SECTION H

When storing the AT500H Seed Treater for long periods of time, the following procedure must be followed to reduce the chance of rust, corrosion and fatigue of the treater. You can also use these steps when storing the machine for the winter.



A dust mask and protective rubber gloves shall be used when cleaning the machine.

ATOMIZER CHAMBER

1. Remove and clean the atomizer housing.
2. Remove the atomizer head and stainless steel plumbing. The atomizer head can be disassembled (right), for easier cleaning. It is threaded together and can simply be unscrewed.
3. Reinstall the atomizer head and plumbing. Grease the bearing and spin the atomizer head a few times to ensure all grease has been worked into the bearings.

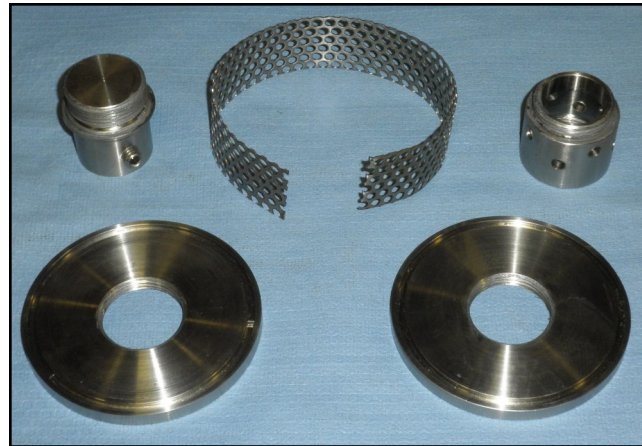

AUGER

1. Grease upper and lower bearings on auger.
2. Remove shield and check tension on belt.
3. Open the bottom clean out door to remove any debris (compressed air can be used).

FINAL

1. Store the machine inside a protective building to keep it from being exposed to the weather. Ensure transport levers are placed in the "up" position prior to moving the AT500H.
2. Disconnect power to the machine.
3. Ensure all guards and safety labels are in place.

AT500H TREATER

Proper Storage of the treater for long periods of time is critical to reduce the chance of rust, corrosion and fatigue of the equipment. This is especially true when storing the treater in below freezing temperatures.

The following is a guideline for the type of cleaning and maintenance that should be performed on this unit prior to storage. Your environment and uses may require additional cleaning and preparation to assure that when the equipment is returned to production, it performs in a safe, accurate and reliable manor.



A dust mask and protective rubber gloves shall be used when cleaning the machine.

PUMPS - PLUMBING - FLOW METERS

1. Perform steps 1 through 9 on page 56 in the pumps and plumbing section of the maintenance section to clean the chemical residue from each pump.

NOTICE

If the treater will be exposed to possible freezing temperatures, the final flush of the system should be made with a non freezable liquid like recreational vehicle antifreeze.

2. Release pump heads and remove tubing to prevent any unnecessary wear (see page 20).
3. Disconnect power to the volumetric flow meter and perform steps 10A through 10D on page 57 in the maintenance section.
4. Stand the flow meter upright allowing enough time for measuring pipe to air dry. After it is dry, cover both openings.
6. Store flow meters in a location with the following conditions:
 - Ambient temperature of 50 to 80 degrees Fahrenheit.
 - Protection from direct sunlight to avoid unacceptable high surface temperatures.
 - Where moisture does not collect in or on the flow meter. This will help prevent fungus or bacteria infestation which can damage the liner.
 - Store in a manner so that the inlet and outlet are as much in an up and down position as possible.

AT500H TREATER

NOTES:

SECTION I USC LIMITED WARRANTY

USC, LLC, MANUFACTURER WARRANTY ON SEED TREATING EQUIPMENT

01AUG22

USC, LLC, (Manufacturer) warrants its equipment as follows:

1.Limited Warranty: Manufacturer warrants that the Products sold hereunder will be free from defects in material and workmanship for a period of 18 months from date of shipment by Manufacturer for all seed treating equipment and a period of 12 months from date of shipment by Manufacturer for all grain and fertilizer handling equipment.

If the Products do not conform to this Limited Warranty during the warranty period, Buyer shall notify Manufacturer in writing (on the approved USC warranty claim form) of the claimed defects and demonstrate to Manufacturer satisfaction that said defects are covered by this Limited Warranty (through pictures, video or other objective data). If the defects are properly reported to Manufacturer within the warranty period, and the defects are of such type and nature as to be covered by this warranty, Manufacturer shall, at its expense, furnish replacement Products or, at Manufacturer's option, replacement parts for the defective products. Shipping and installation of the replacement Products or replacement parts shall be at the Buyer's expense.

All replacement parts orders through Manufacturer will carry their specific manufacturer's standard warranty. There is no warranty on replacement parts manufactured by Manufacturer. Manufacturer will not extend any warranty due to replaced parts. The end user is responsible for all shipping and handling expenses for parts returned to Manufacturer under this section which may or may not be included in that specific warranty. Manufacturer will pay shipping expense between USC and its vendor.

2.Other Limits: THE FOREGOING IS IN LIEU OF ALL OTHER WARRANTIES, EXPRESSED OR IMPLIED, INCLUDING BUT NOT LIMITED TO THE IMPLIED WARRANTIES OF MERCHANTABILITY AND FITNESS FOR A

PARTICULAR PURPOSE. Manufacturer does not warrant against damages or defects arising from improper installation (where installation is by persons other than Manufacturer), against defects in products or components not manufactured by Manufacturer, or against damages resulting from such non-Manufacturer made products or components. Manufacturer passes on to the Buyer the warranty it received (if any) from the maker of such non-Manufacturer made products or components. This warranty also does not apply to Products upon which repairs and / or modifications have been affected or attempted by persons other than pursuant to written authorization by Manufacturer. This includes any welding on equipment which could damage electrical components. Manufacturer does not warrant against injuries or damages resulting from misuse and / or abuse of Products, improper storage or handling, acts of nature, effects of weather, including effects of weather due to outside storage, accidents, or damages incurred during transportation by common carrier or Dealer/customer arranged freight. Any replacement or repair covered under this warranty will not extend the warranty period. The remainder of the manufacturer's warranty will remain in force until stated expiration.

3.Exclusive Obligation: THIS WARRANTY IS EXCLUSIVE. The sole and exclusive obligation of Manufacturer shall be to repair or replace the defective Products in the manner and for the period provided above. Manufacturer shall not have any other obligation with respect to the Products or any part thereof, whether based on contract, tort, strict liability or otherwise. Under no circumstances, whether based on this Limited Warranty or otherwise, shall Manufacturer be liable for lost profits, lost revenue, lost sales (whether direct or indirect damages), incidental, special, punitive, indirect or consequential damages. Buyer shall make no claims for remuneration for any loss as a result of USC equipment and USC shall reject any and all claims that may arise as stated herein.

4.Other Statements: Manufacturer's employees or representatives' oral or other written statements do not constitute warranties, shall not be relied upon by Buyer, and are not a part of the contract for sale or this limited warranty. The USC Warranty Manager is the final decision point for all warranty claims.

5.Return Policy: Approval is required prior to returning goods to Manufacturer irrespective of warranty claim. Manufacturer may give a credit, less a 15% restocking fee, for goods that are returned in new, sellable condition. Items returned for warranty that are found to be not covered by the warranty will remain the property of the Buyer. The Buyer will have the ability to have part returned at their expense or, if in new, sellable condition, receive a credit less a 15% restocking fee and less any USC paid freight for its return.

6.Entire Obligation: This Limited Warranty states the entire obligation of Manufacturer with respect to the Products. If any part of this Limited Warranty is determined to be void or illegal, the remainder shall remain in full force and effect. Other terms included in Manufacturer's Terms of Sale will also apply.

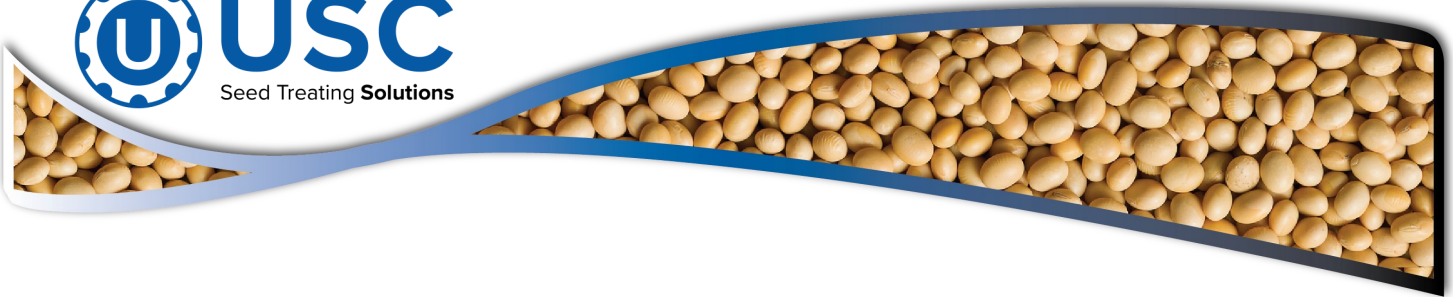

DOCUMENT REVIEW RECORD	
DATE	
10-2022	JHT
1-2023	JHT

USC, LLC

2320 124th Road

Sabetha, KS 66534

Phone (785) 431-7900

EMAIL: sales-team@uscllc.com

WEB: www.uscllc.com

