

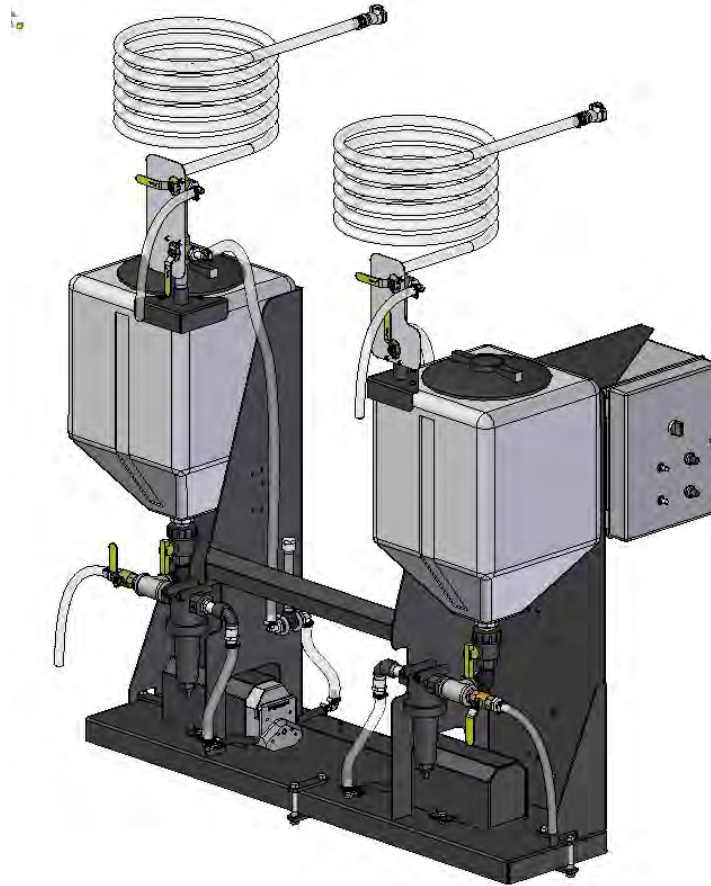

AT500H DUAL PUMPSTAND UPGRADE KIT

Operators Manual



Document: TD-09-06-3039

Revision: A



INTRODUCTION

Thank you for choosing USC, LLC for your equipment needs. We appreciate your business and will work diligently to ensure that you are satisfied with your choice.

OVERVIEW

The purpose of this manual is to provide you with the basic information needed to install operate and maintain the AT500H Dual Pump Stand . It does not hold USC, LLC liable for any accidents or injuries that may occur.

The technical information provided in this document is based on extensive testing under controlled conditions at the USC research and development facility. This information is given without guarantee as the conditions of operation and storage of the equipment are beyond our control. Variables such as temperature, humidity, viscosity of chemical products and changes in seed size or variety may all effect the accuracy of application and seed coverage. Periodically check the equipment calibration while treating and make adjustments as required. This will insure the optimum seed coverage.

OPERATOR RESPONSIBILITIES

As the purchaser/owner/operator of this equipment and control system, you have an obligation to install, operate, and maintain the equipment in a manner that minimizes the exposure of people in your care to any potential hazards inherent in using this equipment. It is critical that the owner of this equipment:

- Has a clear and documented understanding of the process this machine is being used in and of any resulting hazards or special requirements arising from this specific application.
- Allow only properly trained and instructed personnel to install, operate or service this equipment.
- Maintain a comprehensive safety program involving all who work with this machine and other associated process equipment.
- Establish clear areas of staff responsibility (e.g. operation, setup, sanitation, maintenance, and repairs).
- Provide all personnel with necessary safety equipment.
- Periodically inspect the equipment to insure that the doors, covers, guards, and safety devices are in place and functioning, that all safety instructions and warning labels are intact and legible, and that the equipment is in good working order.
- In addition to the operating instructions, observe and enforce the applicable legal and other binding regulations, national and local codes.

AT500H DUAL PUMP STAND KIT

As the person with the most to gain or lose from working safely, it is important that you work responsibly and stay alert. By following a few simple rules, you can prevent an accident that could injure or kill you or a co-worker.

- Disconnect, lockout, and tagout electrical and all other energy sources before inspecting, cleaning, servicing, repairing, or any other activity that would expose you to the hazards of electrical shock.
- Do not operate, clean, or service this equipment until you have read and understood the contents of this manual. If you do not understand the information in this manual, bring it to the attention of your supervisor, or call USC at (785) 431-7900 for assistance.
- Any operator who is known or suspected to be under the influence of alcohol or drugs should not be allowed to operate the equipment.
- Understand and follow the safety practices required by your employer and this manual.
- **PAY ATTENTION** to what you and other personnel are doing and how these activities may affect your safety.
- **Failure to follow these instructions may result in serious personal injury or death.**

RECEIVING YOUR EQUIPMENT

As soon as the equipment is received, it should be carefully inspected to make certain that it has sustained no damage during shipment and that all items listed on the packing list are accounted for. If there is any damage or shortages, the purchaser must immediately notify USC, LLC. Ownership passes to purchaser when the unit leaves the USC, LLC. premises. The purchaser is responsible for unloading and mounting all components of the equipment.

Document the serial number of the machine for future reference. The serialization label is located on the back of the control panel bracket.



SERIAL NUMBER: _____

TABLE OF CONTENTS

<u>Section</u>	<u>Contents</u>	<u>Page #</u>
Section A	Safety Instructions	5
Section B	Installation	13
Section C	Mechanical Operation	15
Section D	Electrical Operation	17
	Pump Calibration.....	19
	Pump Stand Operation.....	22
Section E	Troubleshooting	23
Section F	Maintenance	24
Section G	Storage.....	27
Section H	Mechanical Drawing.....	28
Section I	Limited Warranty.....	41

SAFETY INSTRUCTIONS

SECTION A

Every year accidents in the work place maim, kill and injure people. Although it may be impossible to prevent all accidents, with the right combination of training, operating practices, safety devices, and operator vigilance, the number of accidents can be significantly reduced. The purpose of this section is to educate equipment users about hazards, unsafe practices, and recommended hazard avoidance techniques.

SAFETY WORDS AND SYMBOLS

It is very important that operators and maintenance personnel understand the words and symbols that are used to communicate safety information. Safety words, their meaning and format, have been standardized for U.S. manufacturers and published by the American National Standards Institute (ANSI). The European Community (E.C.) has adopted a different format based on the International Standards Organization (I.S.O.) and applicable machinery directives. Both formats are presented below. Graphic symbols are not standardized, but most manufacturers will use some variation of the ones seen in this manual.



Indicates an imminently hazardous situation which, if not avoided, **will** result in death or serious injury.



Indicates a potentially hazardous situation which, if not avoided, **could** result in death or serious injury.



Indicates a potentially hazardous situation which, if not avoided, **may** result in minor or moderate injury and/or property damage.



Provides additional information that the operator needs to be aware of to avoid a potentially hazardous situation.



Mandatory Lockout Power Symbol. Disconnect, lockout and tagout electrical and other energy sources before inspecting, cleaning or performing maintenance on this panel.



International Safety Alert Symbol. The exclamation point (!) surrounded by a yellow triangle indicates that an injury hazard exists. However, it does not indicate the seriousness of potential injury. The exclamation point (!) is also used with the DANGER, WARNING and CAUTION symbols so the potential injury is indicated.



Electrocution Hazard Symbol. This symbol indicates that an electrocution hazard exists. Serious injury or death could result from contacting high voltage.



International Electrocution Hazard. This symbol indicates that an electrocution hazard exists. Serious injury or death could result from contacting high voltage.



Mandatory Read Manual Action Symbol. (I.S.O. format) This symbol instructs personnel to read the Operators Manual before servicing or operating the equipment.



Mandatory Read Manual Action Symbol. This symbol instructs personnel to read the Operators Manual before servicing or operating the equipment.



Notice is used to notify people of important installation, operation or maintenance information which is not hazard related.

LOCKOUT / TAGOUT PROCEDURES

Lockout/Tagout is the placement of a lock/tag on an energy isolating device in accordance with an established procedure. When taking equipment out of service to perform maintenance or repair work, always follow the lockout/tagout procedures as outlined in ANSI Z344.1 and/or OSHA Standard 1910.147. This standard “requires employers to establish a program and utilize procedures for affixing appropriate lockout devices or tagout devices to energy isolating devices and to otherwise disable machines or equipment to prevent unexpected energizing, start-up, or release of stored energy in order to prevent injury to employees.”

HAZARD REVIEW

Electrocution Hazard



Electrocution accidents are most likely to occur during maintenance of the electrical system or when working on or near exposed high voltage wiring. This hazard does not exist when the electrical power has been disconnected, properly locked, and tagged out.

Automatic Start Hazard



The equipment may be controlled by an automated system and may start without warning. Failure to properly disconnect, lockout, and tagout all energy sources of remotely controlled equipment creates a very hazardous situation and could cause injury or even death. PLEASE STAY CLEAR AND BE ALERT.

YOU are responsible for the **SAFE** operation and maintenance of your USC, LLC equipment . **YOU** must ensure that you and anyone else who is going to operate, maintain, or work around the treater be familiar with the operating and maintenance procedures and related **SAFETY** information contained in this manual. This manual will take you step-by-step through your working day and alert you to good safety practices that should be adhered to while operating the treater.

Remember, **YOU** are the key to safety. Good safety practices not only protect you, but also the people around you. Make these practices a working part of your safety program. Be certain that **EVERYONE** operating this equipment is familiar with the recommended operating and maintenance procedures and follows all the safety precautions. Most accidents can be prevented. Do not risk injury or death by ignoring good safety practices.

- Equipment owners must give operating instructions to operators or employees before allowing them to operate the machine, and at least annually thereafter per OSHA (Occupational Safety and Health Administration) regulation 1928.57.
- The most important safety device on this equipment is a **SAFE** operator. It is the operator's responsibility to read and understand **ALL** Safety and Operating instructions in the manual and to follow them. All accidents can be avoided.
- A person who has not read and understood all operating and safety instructions is not qualified to operate the machine. An untrained operator exposes himself and bystanders to possible serious injury or death.
- Do not modify the equipment in any way. Unauthorized modification may impair the function and/or safety and could affect the life of the equipment.
- Think SAFETY! Work SAFELY!

GENERAL SAFETY

1. Read and understand the Operator's Manual and all safety labels before operating, maintaining, adjusting or unplugging the seed treater .
2. Only trained persons shall operate the seed treater. An untrained operator is not qualified to operate the machine.
3. Have a first-aid kit available for use should the need arise, and know how to use it.



4. Provide a fire extinguisher for use in case of an accident. Store in a highly visible place.
5. Do not allow children, spectators or bystanders within hazard area of machine.
6. Wear appropriate protective gear. This includes but is not limited to:
 - A hard hat
 - Protective shoes with slip resistant soles
 - Protective goggles
 - Heavy gloves
 - Hearing protection
 - Respirator or filter mask
7. Place all controls in neutral or off, stop motor, and wait for all moving parts to stop. Then disable power source before servicing, adjusting, repairing, or unplugging.
8. Review safety related items annually with all personnel who will be operating or maintaining the Equipment.



OPERATING SAFETY:

1. Read and understand the Operator's Manual and all safety labels before using.
2. Disconnect and disable electrical supply completely and wait for all moving parts to stop before servicing, adjusting, repairing or unplugging.
3. Clear the area of bystanders, especially children, before starting.
4. Be familiar with the machine hazard area. If anyone enters hazard area, shut down machine immediately. Clear the area before restarting.
5. Keep hands, feet, hair and clothing away from all moving and/or rotating parts.
6. Stay away from overhead obstructions and power lines during operation and transporting. Electrocutation can occur without direct contact.
7. Do not operate machine when any guards are removed.
8. Inspect welds and repair if needed.

PLACEMENT SAFETY

1. Move only with the appropriate equipment
2. Stay away from overhead power lines when moving the treater. Electrocution can occur without direct contact.
3. Be familiar with machine hazard area. If anyone enters hazard areas, shut down machine immediately. Clear the area before restarting.
4. Operate the treater on level ground free of debris. Anchor the treater to prevent tipping or upending.



Before placement of the pump stand, be sure that ground is reasonably level. The pump stand may topple or work improperly if the ground is too uneven, damaging the equipment and/or causing personal injury.

MAINTENANCE SAFETY

1. Review the Operator's Manual and all safety items before working with, maintaining or operating the Equipment .
2. Place all controls in neutral or off, stop motors, disable power source, and wait for all moving parts to stop before servicing, adjusting, repairing or unplugging.
3. Follow good shop practices:
Keep service area clean and dry.
Be sure electrical outlets and tools are properly grounded.
Use adequate light for the job at hand.
4. Keep hands, feet, hair and clothing away from all moving and/or rotating parts.
5. Clear the area of bystanders, especially children, when carrying out any maintenance and repairs or making any adjustments.
6. Before resuming work, install and secure all guards when maintenance work is completed.
7. Keep safety labels clean. Replace any sign that is damaged or not clearly visible.



SAFETY LABELS

1. Keep safety labels clean and legible at all times.
2. Replace safety labels that are missing or have become illegible.
3. Replaced parts that displayed a safety sign should also display the current sign.
4. Replacement safety labels are available. Contact USC at (785) 431-7900 .

How to Install Safety Labels:

- Be sure that the installation area is clean and dry.
- Be sure temperature is above 50°F (10°C).
- Decide on the exact position before you remove the backing paper.
- Remove the smallest portion of the split backing paper.
- Align the sign over the specified area and carefully press the small portion with the exposed sticky backing in place.
- Slowly peel back the remaining paper and carefully smooth the remaining portion of the sign in place.
- Small air pockets can be pierced with a pin and smoothed out using the piece of sign backing paper.



Located on the USC equipment you will find safety labels. Always be sure to read and follow all directions on the labels.



Guards provided with USC equipment are to remain in place during operation.

AT500H DUAL PUMP STAND KIT

Think **SAFETY!** Work **SAFELY!**

REMEMBER—If Safety Labels have been damaged, removed, become illegible, or parts replaced without safety labels, new labels must be applied. New safety labels are available from USC at (785) 431-7900.

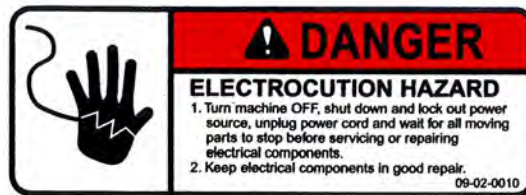

Part # 09-02-0010

INSTALLATION

SECTION B



HIGH VOLTAGE ~ Always disconnect the power source before working on or near the control panel or lead wires.



HIGH VOLTAGE ~ Use insulated tools when making adjustments while the controls are under power.

NOTICE

Permanent installation may require additional electrical cords, chemical tubing, and air lines, since each installation is unique.

1. Place the pump stand assembly on the front of the treater frame. Make sure the pump stand base slides back until the front lip makes contact with the front of the treater frame.
2. Use the three mounting plates (1054C4), six 3/8" X 3.50" bolts (06-01-0022) and six 3/8" nuts (06-03-0014) to secure the assembly to the treater as shown below.

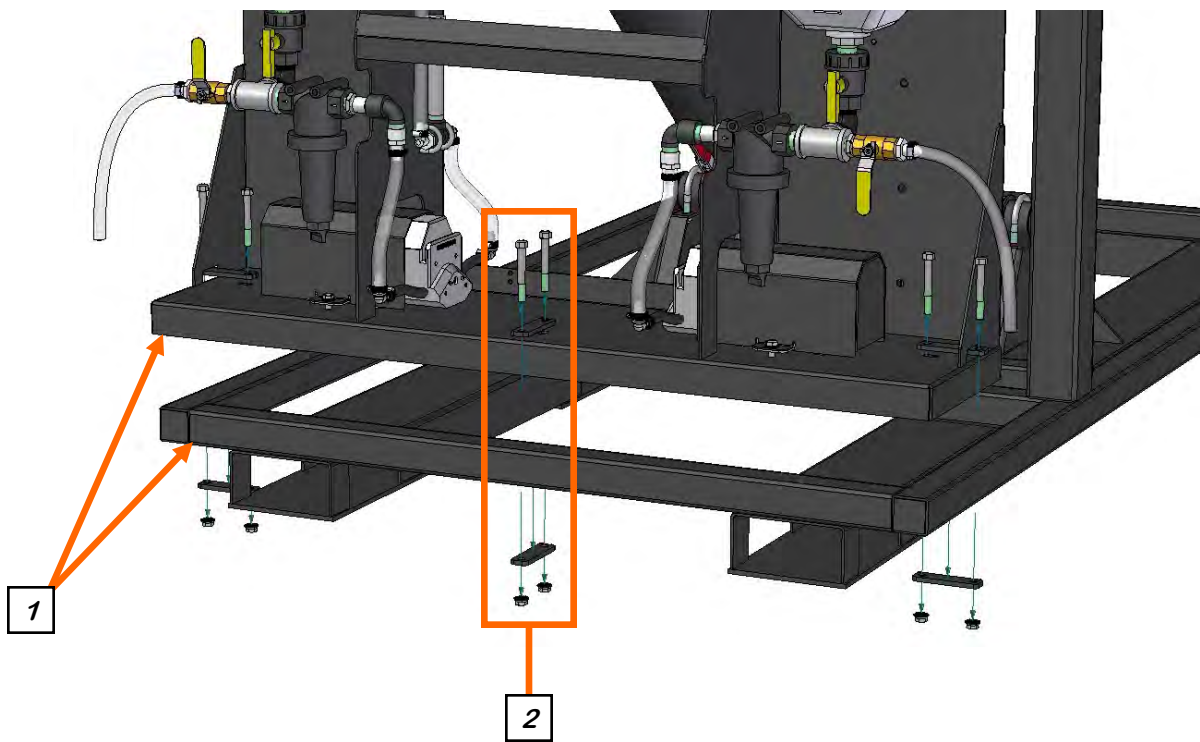

INSTALLATION

3. Connect the Treater Auxiliary Signal cable (PJ3005) on the bottom of the pump stand control panel to one of the Auxiliary Ports (PJ1203 - PJ1206) on the bottom of the treater control panel.

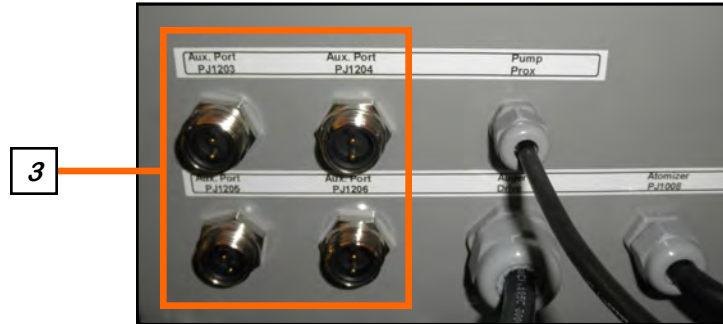

4. Plug the power cord (PJ3001) into a properly grounded 110V outlet.
5. Connect the quick disconnect on the hoses connected to the top valve on both pump stands to one of the valves on the static mixer assembly located under the treater control panel.
6. After all of the connections are complete, use wire tie wraps to secure both treatment hoses and the auxiliary cable to the treater. Run them down the vertical frame post next to the pump stand control panel, along the bottom of the frame and back up the post the static mixer and treater control panel are mounted.

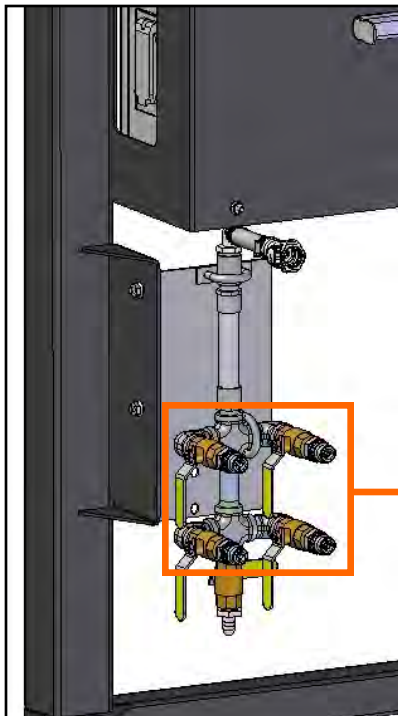

NOTICE

Do not overtighten the tie wraps. Make sure not to restrict the flow of treatment as it is pumped to the treater.

MECHANICAL OPERATION

SECTION C

PERISTALTIC PUMP HEAD AND MOTOR

The pump stand utilizes a variable speed pump motor and special norprene pump tubing for liquid metering. Each pump comes equipped with 1 peristaltic pump head. Liquid will only come into contact with the inside diameter of the pump tubing and not the pump. This allows for easy cleanup and less maintenance of the pump.

To open the pump head, rotate the lever to the left. Place the pump tubing inside the pump head so it fits inside the notches and above the rollers (bottom, left). Rotate the lever back to the right and close the pump head, clamping the hose inside the head (bottom, right). Wear or fatiguing of the tubing within the pump head due to compression is normal. When tubing becomes worn or chemical rates begin to slow down, open the pump head and move the tubing to a different position. If the entire piece of tubing becomes worn, simply replace with a new section. When not using the pump stand for several days or when storing, open the pump head and remove the tubing to prevent any extra compression.



Pump Head Open

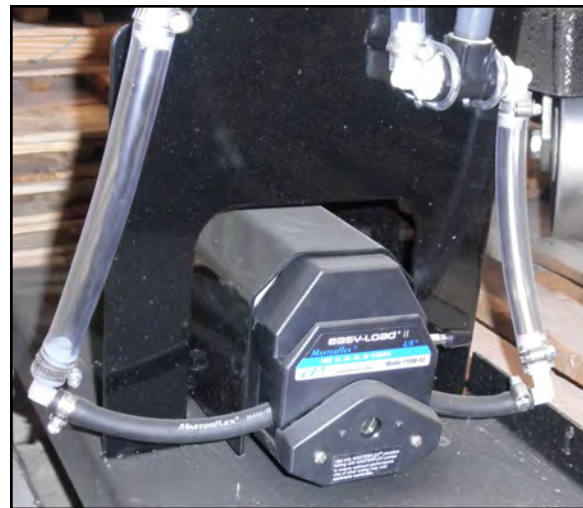

Pump Head Closed

SEED TREATMENT VALVES

SEED TREATMENT VALVES (Left Pump Stand): When the handle of the bottom valve is in the horizontal position the liquid recirculates back into the top of the tank. In the vertical position it sends the liquid up to the top valve.

When the handle of the top valve is in the horizontal position the liquid is directed to the short, unconnected tube so the liquid may flow into a measuring container for pump calibration purposes. In the vertical position it sends the liquid to the treater.

SEED TREATMENT VALVES (Right Pump Stand): When the handle of the bottom valve is in the vertical position the liquid recirculates back into the top of the tank. In the horizontal position it sends the liquid up to the top valve.

When the handle of the top valve is in the horizontal position the liquid is directed to the short, unconnected tube so the liquid may flow into a measuring container for pump calibration purposes. In the vertical position it sends the liquid to the treater.



Left Tank Source Valve



Right Tank Source Valve

ELECTRICAL OPERATION

SECTION D



HIGH VOLTAGE ~ Always disconnect the power source before working on or near the control panel or lead wires.



HIGH VOLTAGE ~ Use insulated tools when making adjustments while the controls are under power.



AUTHORIZED PERSONNEL only shall work on the control panel. Never allow anyone who has not read and familiarized themselves with the owner's manual to open or work on the control panels.

This section provides a general overview and description of the operator controls for the pump stands.

General Panel Descriptions:

The pump stand control panel is a plug connected enclosure that is located on the pump stand frame. This panel connects the pump stand electrical components to the treater panel. The pump stand has four cables. One connected to each pump motor, one connecting to the treater panel and one standard 110V plug.

ELECTRICAL OPERATION



1. CHEMICAL PUMP SWITCH: When this switch is turned to HAND, the chemical pump will run. When the switch is turned to AUTO, the chemical pump will only run when the Auxiliary Ports H-O-A switch on the treater control panel is set to HAND or AUTO. The 2-Wire auxiliary cable on the pump stand panel must be connected to the auxiliary port on the treater control panel for this feature to work. When placed in AUTO, it will only run when the proximity switch located in the bottom of the seed treater supply hopper detects seed and the atomizer is running. The proximity switch determines when seed is present in the hopper. When the proximity switch no longer detects seed, a time delay defined inside the treater control panel will automatically shut off the chemical pump at a pre-determined amount of time after the hopper has emptied. The time delay allows all seed in the hopper to receive equal coverage.

3. CHEMICAL PUMP DIRECTION SWITCHES: These switches allow the operator to change the pump direction between forward, off and reverse. It has a safety feature that will not allow the operator to switch from forward to reverse or vice-versa without momentarily stopping and releasing the switch in the center position.

4. PUMP SPEED DIALS: These dials allow the operator to increase or decrease the speed of pump. The setting should be chosen in relation to the desired application rate for the treatment being applied to the seed.

PUMP CALIBRATION

The following steps illustrate how to calibrate the peristaltic pump motor. A stop watch will be needed in the calibration process.

1. Lock down the pump tubing on all peristaltic pump head (see page 15).
2. Premix enough liquid for the amount of seed you will be treating and pour into the mix tank. It's always a good practice to mix up 20% extra slurry to help fill all the lines.
3. Place the top valve to the CALIBRATE position. Place the bottom valve to RECIRCULATE position.
4. Turn the pump direction switch to FORWARD.
5. Turn the HAND / OFF / AUTO switch to the HAND position and set the pump LIQUID ADJ. dial (right, bottom) to about 500 or half speed. The liquid should begin re-circulating from the bottom of the mix tank, through the pump, and back into the top of the mix tank.
6. Allow pump to re-circulate liquid for approximately 15 minutes to ensure all air has been removed from the liquid lines. This will also help break-in the pump tubing, which is critical before checking pump calibration.
7. After you have allowed the liquid to re-circulate you are ready to calibrate the pump. To determine the number of ounces needed in one minute, you will need to know the seed flow rate from the seed treater.



EXAMPLE: The seed treatment slurry rate is 4 ounces per cwt.

Seed Flow Rate = 6.41 cwt / min. x 4 oz./ cwt. = 25.6 oz./min.

25.6 oz. is the rate the pump should be pumping in one minute.

PUMP CALIBRATION

8. You will need a stopwatch and a measuring receptical marked with ounces and / or mililletters to perform the calibration.
9. Set the Liquid Adjustment Dial . You can use the chart on page 21 to find a starting point.

EXAMPLE:

The ounces needed in one minute = 25.6 oz/min.
An approximate dial starting point is 310.

9. Turn the Pump Control switch to the OFF position. Place the bottom valve to the TO PROCESS / CALIBRATE position. Hold the measuring container under the calibration hose coming from the top valve. Turn the Pump Control valve to the HAND position. As soon as the liquid begins to flow into the container start the stopwatch. When the stopwatch reaches one minute, turn the switch to the OFF position.
10. Place the measuring container on a flat and level surface. Note the total ounces of chemical that is in the container. This number should equal the number of ounces needed to flow through the pump in one minute. If the ounces needed per minute have not been met, re-adjust the pump speed up or down accordingly and repeat steps 9 and 10 until the liquid flow rate has been matched.
11. Once you have the pump adjusted to the correct speed, Push the lock down lever on the top of the pump speed dial to the left to lock it in place.

NOTICE

USC recommends the operator write down the pump speed setting as well as the seed type, size, variety and other information associated with the seed. Over time, enter this information into an Excel spread sheet creating a reference database that will reduce the amount of time spent adjusting the treatment flow.

PUMP CALIBRATION

Below are two charts that show the oz / min and ml / min at different dial settings.

NOTICE All calibrations were done using water. Numbers are not exact, only use these numbers as a starting point.

Standard Data

Dial Setting	oz / Min
50	7.4
100	10.5
150	14.1
200	17.7
250	21.3
300	24.9
350	28.5
400	32.1
450	35.7
500	39.3
550	42.9
600	46.5
650	50.1
700	53.7
750	57.3
800	60.9
850	64.5
900	68.1
950	71.7
1000	75.3

Metric Data

Dial Setting	ml / Min
50	219
100	302
150	417
200	524
250	630
300	737
350	843
400	950
450	1056
500	1162
550	1268
600	1375
650	1482
700	1588
750	1695
800	1800
850	1908
900	2014
950	2121
1000	2227

PUMP STAND OPERATION

Once the pumps have been calibrated, the panel settings will determine which pumps will be used for each treatment run. After they are set, the rest of the treating process will be controlled from the panel on the AT500 treater. For more information see the AT500 treater operators manual **TD-09-06-1034**.

PUMP CONTROL SETTINGS

1. Check to be sure the Pump speed dials are set correctly and locked in place.
2. Turn the Pump Control switch to the AUTO position.
3. Put the toggle switch in the FORWARD position for the pumps that will be used for the run. The pump stand will now be controlled by the treater.
4. When the treating process is complete, turn the Pump Control switch to the OFF position.
5. Toggle the switch for each pump that was used in the reverse position.
6. Turn the Pump Control switch to the HAND position and let the pumps run until all treatment has drained from the tubing back in to the mix tank(s). Turn the switch to the OFF position.

TROUBLESHOOTING**SECTION
E**

Below is a table describing the most frequent problems and solutions with the Dual Pump Stand. For further assistance, contact the USC Service department at (785) 431-7900.

Problem	Possible Cause	Solution
Pump is fluctuating.	<ol style="list-style-type: none"> 1. Restriction in tubing 2. Filter is plugged or missing gasket. 3. Hoses are worn out. 	<ol style="list-style-type: none"> 1. Flush tubing and check filter for any restrictions. 2. Clean filter and check for gasket. 3. Replace hoses.
Pump will not turn off in AUTO when seed runs out.	<ol style="list-style-type: none"> 1. Proximity switch is dirty. 2. Proximity switch is set too sensitive. 	<ol style="list-style-type: none"> 1. Clean proximity switch. 2. Adjust the pump proximity switch sensitivity by turning adjustment screw counter-clockwise.
Pump will not turn on in AUTO.	<ol style="list-style-type: none"> 1. Proximity switch is not staying covered. 2. Proximity switch is not sensitive enough. 3. HMI screen not set to AUTO. 4. Auxiliary cable not connected. 	<ol style="list-style-type: none"> 1. Make sure proximity switch is staying covered with seed. 2. Adjust pump proximity switch sensitivity by turning the adjustment screw clockwise. 3. Set HMI screen to AUTO. 4. Attach Auxiliary cable from control panel to treater control panel.
Mix Motor will not start	<ol style="list-style-type: none"> 1. Power cord not plugged in. 	<ol style="list-style-type: none"> 1. Plug in power cord.

**SECTION
F****MAINTENANCE**

Proper maintenance of the pump stands is critical for peak performance, reliability and accuracy of this system. The following is a guideline for the type of maintenance and servicing that should be performed on this unit. Your environment and uses may require additional maintenance and service beyond this list to assure a reliable and safe unit. The operator of this unit has ultimate responsibility to identify areas of concern and rectify them before they become a hazard or safety issue. There is no substitute for a trained, alert operator.



Do not put this unit into operation with any questionably maintained parts. Poor performance or a hazard may occur.

MIX TANK

- Check valves and fittings for leaks.
- Check chemical line tubing for abnormal wear.

ELECTRICAL PANEL

- Check and tighten wire connections.
- Check quick connects on bottom of control panel.
- Check to see if starters and/or overloads are tripped.
- Check to see if relays, timers and/or breakers are tripped.
- Check quick connects on end of Auxiliary cord.
- Check and tighten wire connections.
- Check relay and fuse holder.
- Check power cords for cuts or frays and ensure ground is present.

PUMPS - PLUMBING - FLOW METER

1. Check pump in forward and reverse.
2. Make sure pump heads open and close smoothly.
3. Inspect tubing for uneven wear. Replace pump tubing often to ensure high flow rates can be achieved.
4. Make certain the inside of the mix tank is completely drained of chemical. Use clean water to rinse out all chemical residue, then fill the tank with clean water.
5. Disconnect the discharge process lines from the treater static mixer assembly and direct them to a receptacle large enough to hold all of the water from the mix tank.
6. Pump clean water through all areas of the plumbing and flow meter if applicable. Opening and closing the valves during this process helps to remove residue from the ball valves.
7. Remove and clean the filter.
8. Open all drain points, valves, and filter to let as much of the water drain as possible.
9. If your pump stand is equipped with a volumetric flow meter, disconnect power to the flow meter.
10. If your pump stand is equipped with a volumetric flow meter, remove it from the machine for additional cleaning.

A. Pre - Mix a solution of 90% water and 10% distilled white vinegar.

NOTICE

Only use the vinegar and water solution mixed in these proportions to clean the flow meter. Use of any other cleaners, especially cleaners containing harsh chemicals may permanently damage the sensors and seals inside the flow meter.

PUMPS - PLUMBING

- B. Use a size - matched circular brush with soft plastic bristles. Dip the brush in the solution and gently move it up and down in the measuring pipe to avoid damaging the measuring pipe and sensor electrodes.
- C. Re-peat brushing with fresh fluid until measuring pipe is visually clean.
- D. Flush the flow meter inside and out with clean water to remove any of the cleaning solution residue.



STORAGE**SECTION
G**

Proper Storage of the the pump stands for long periods of time is critical to reduce the chance of rust, corrosion and fatigue of the equipment. This is especially true when storing the pump stand in below freezing temperatures.

The following is a guideline for the type of cleaning and maintenance that should be performed on this unit prior to storage. Your environment and uses may require additional cleaning and preparation to assure that when the equipment is returned to production, it performs in a safe, accurate and reliable manor.



A dust mask and protective rubber gloves shall be used when cleaning the machine.

PUMPS - PLUMBING - FLOW METERS

1. Perform steps 1 through 7 on page 25 in the pumps and plumbing section of the maintenance section to clean the chemical residue from each pump.

NOTICE

If the pump stand will be exposed to possible freezing temperatures, the final flush of the system should be made with a non freezable liquid like recreational vehicle antifreeze.

2. Open all drain points, valves, and filter to let as much of the water drain as possible.
3. Release pump heads and remove tubing to prevent any unnecessary wear (see page 15).
4. If the pump stand is equipped with a volumetric flow meter, disconnect power and perform steps 10A through 10D in the maintenance section. If equipped with a mass flow meter, remove the flow meter from the pump stand and rinse with clean water.
5. Stand the flow meter upright allowing enough time for measuring pipe to air dry. After it is dry, cover both openings.
6. Store flow meters in a location with the following conditions:
 - Ambient temperature of 50 to 80 degrees Fahrenheit.
 - Protection from direct sunlight to avoid unacceptable high surface temperatures.
 - Where moisture does not collect in or on the flow meter. This will help prevent fungus or bacteria infestation which can damage the liner.
 - Store in a manner so that the inlet and outlet are as much in an up and down position as possible.

SECTION
H

MECHANICAL DRAWING

TREATMENT TANK 1 (RIGHT) ASSEMBLY (04-03-0294)

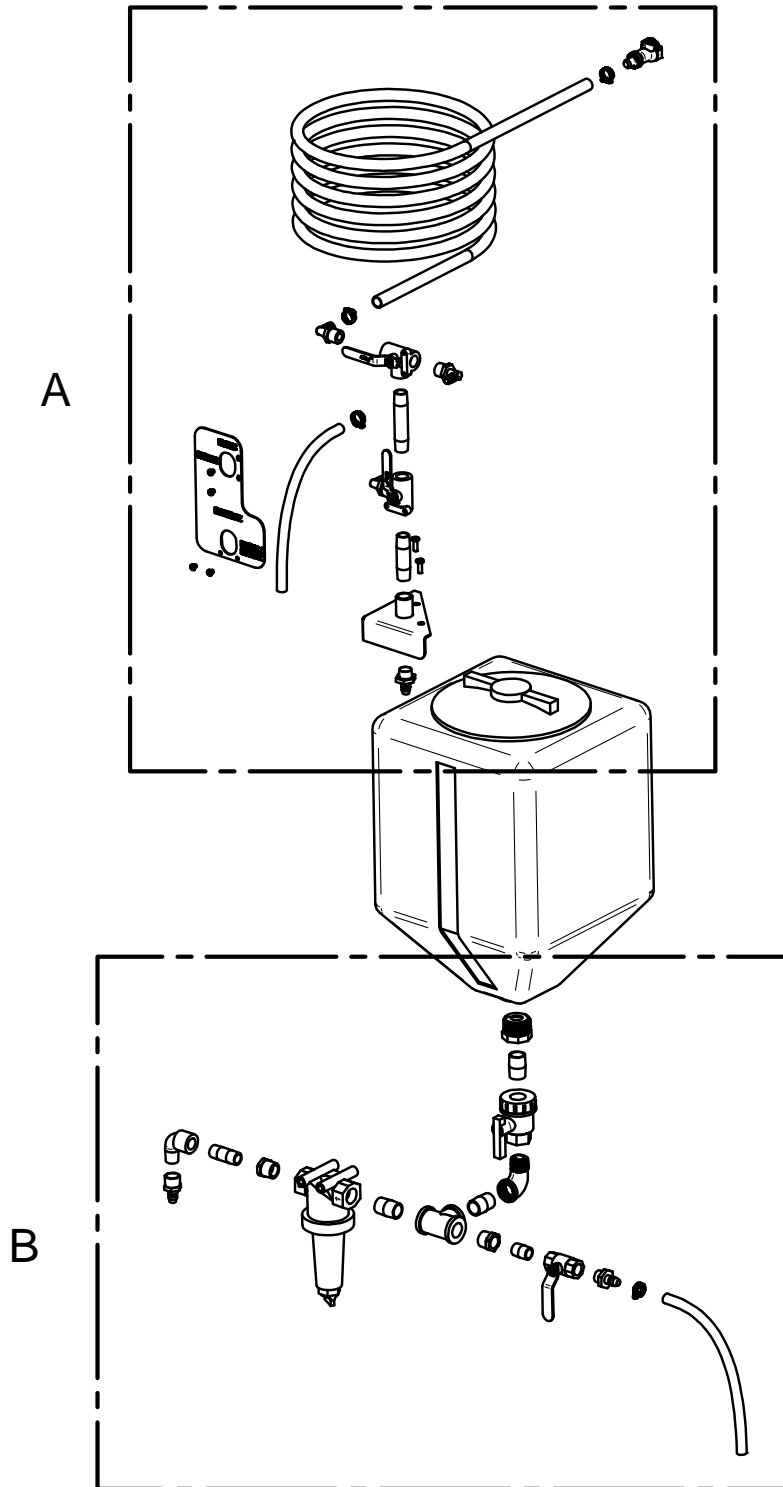

TREATMENT TANK 1 (RIGHT) ASSEMBLY (04-03-0294)

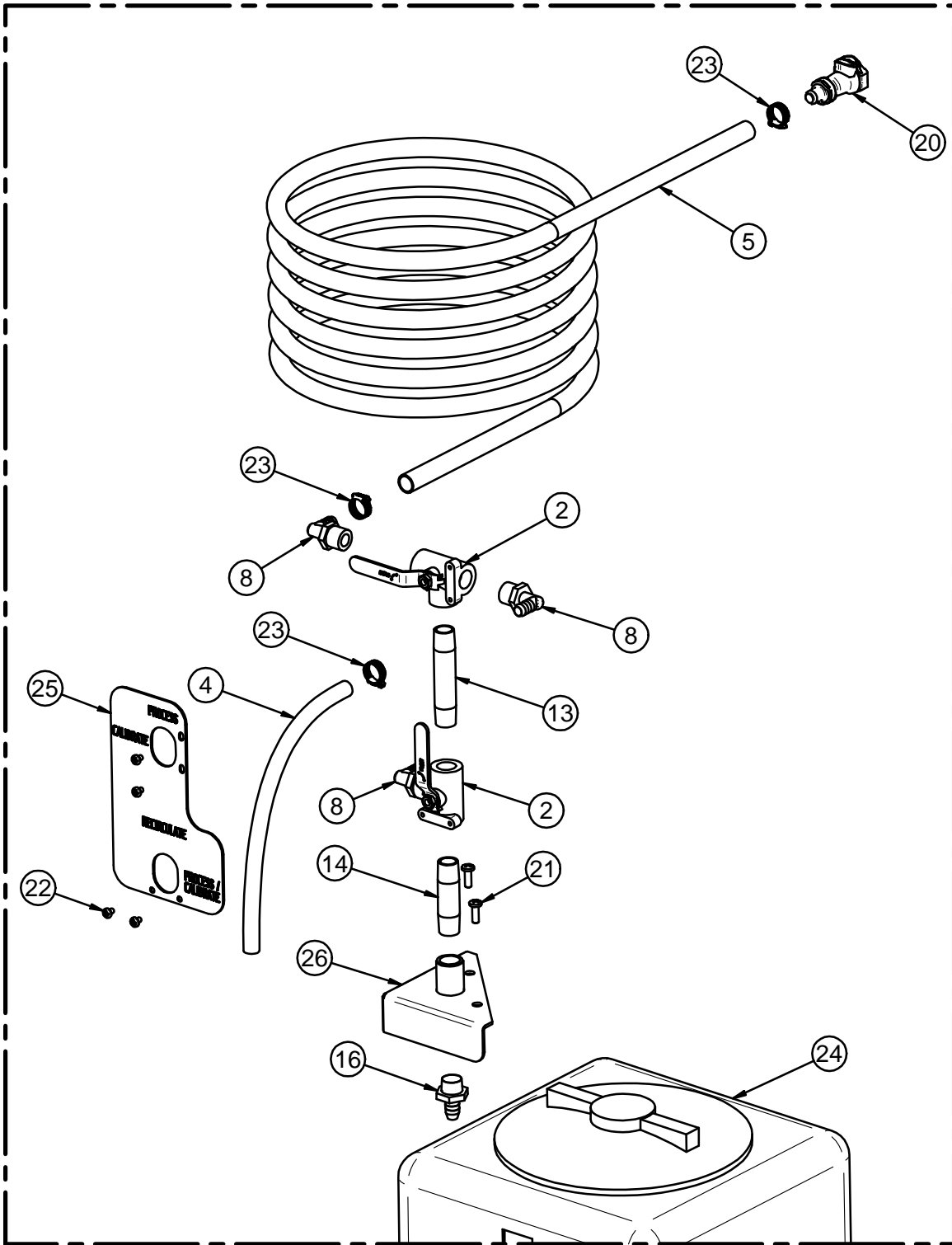

DETAIL A

TREATMENT TANK 1 (RIGHT) ASSEMBLY (04-03-0294)

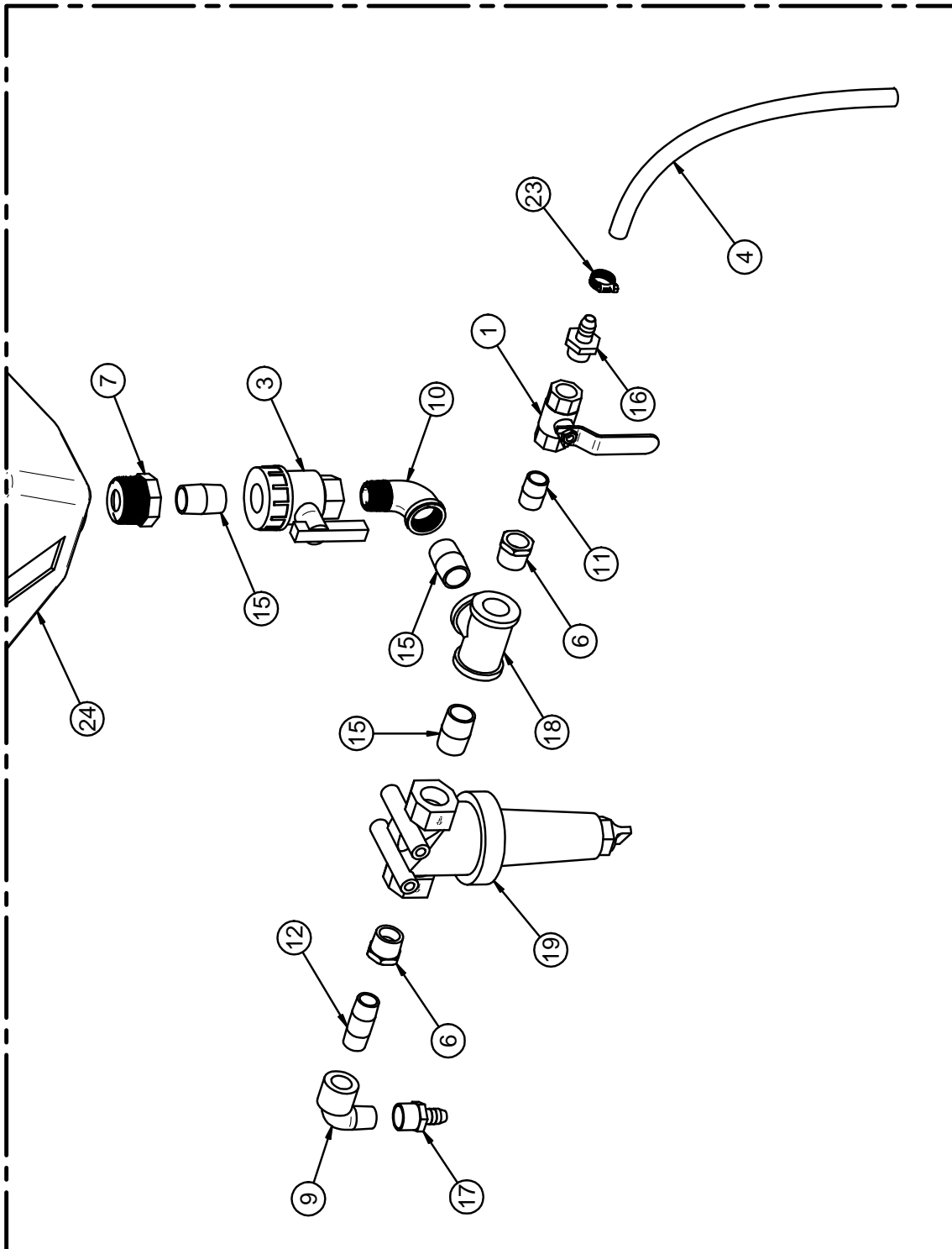

DETAIL B

TREATMENT TANK 1 (RIGHT) ASSEMBLY (04-03-0294)

Item #	Part #	Description	Qty
1	02-02-0006	.500-14 NPT X 2-WAY VALVE	1
2	02-02-0007	VLV BALL .500 NPT 3WAY BRSS	2
3	02-02-0056	VLV BALL .750 NPT FM PLAS	1
4	02-03-0005	DRAIN HOSE PUMP STAND	2
5	02-03-0005	TUBE .50 RNT	1
6	02-04-0008	FTTG BUSH .750NPT X .500NPT SS	2
7	02-04-0051	FTTG BUSH 1.25 X .75 PVC	1
8	02-06-0010	FTTG 90 DEG .500HB X .500NPT ML NYL	3
9	02-06-0017	FTTG 90 DEG STRT .500NPT PPE BLK	1
10	02-06-0068	FTTG 90 DEG STRT .75NPT PPE BLK	1
11	02-07-0007	FTTG NIP .500NPTX1.125 TBE SS CLOSE	1
12	02-07-0010	FTTG NIP .500 NPT X 2.00 TBE SS	1
13	02-07-0013	FTTG NIP .500 NPT X 4.00 TBE SS	1
14	02-07-0019	FTTG NIP .500 NPT X 3.00 TBE SS	1
15	02-07-0070	FTTG NIP .750 NPT X 1.50 TBE SS	3
16	02-08-0007	FTTG STGHT .500HB X .500NPT ML NYL	2
17	02-08-0026	FTTG STGHT .500HB X .500NPT FM NYL	1
18	02-09-0008	FTTG TEE .750 NPT FM SS	1
19	02-12-0011	FLTR TEE PPE .750 NPT 16 MESH BANJO	1
20	02-15-0013	FTTG CPLG .500 HB QCK DISC BODY	1
21	06-01-0215	SCRW MACH #14 X .750 SS PLASTITE	2
22	06-06-0008	SCRW MACH 10-24 X .250 PHLP PHD ZP	4
23	06-07-0006	CLMP HOSE .500 TO .906 X .313W ZP	4
24	07-02-0041	TNK 10GAL POLY SQUARE	1
25	1054B0	VLV LBL	1
26	1054C3	WDMT VALVE MNT PLT	1

TREATMENT TANK 2 (LEFT) ASSEMBLY (04-03-0295)

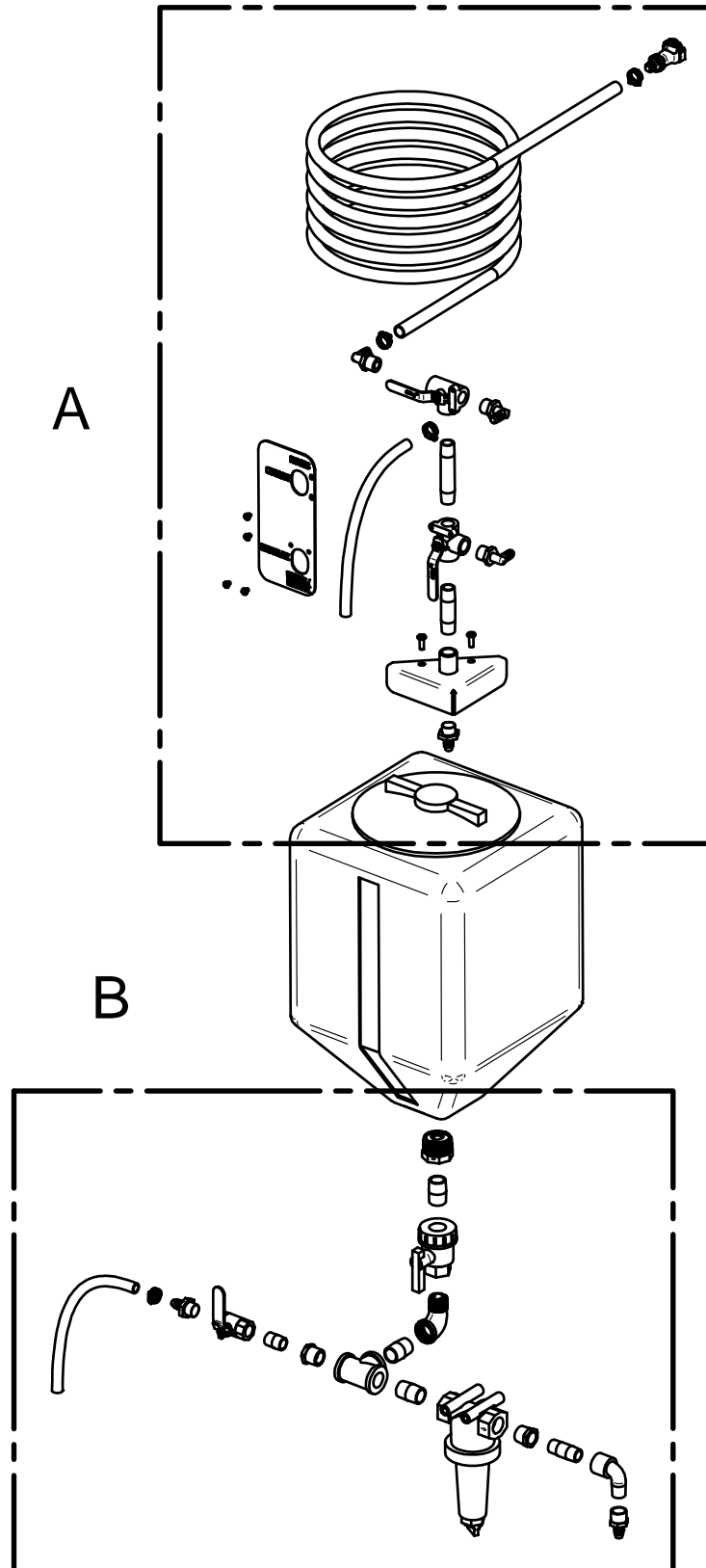

TREATMENT TANK 2 (LEFT) ASSEMBLY (04-03-0295)

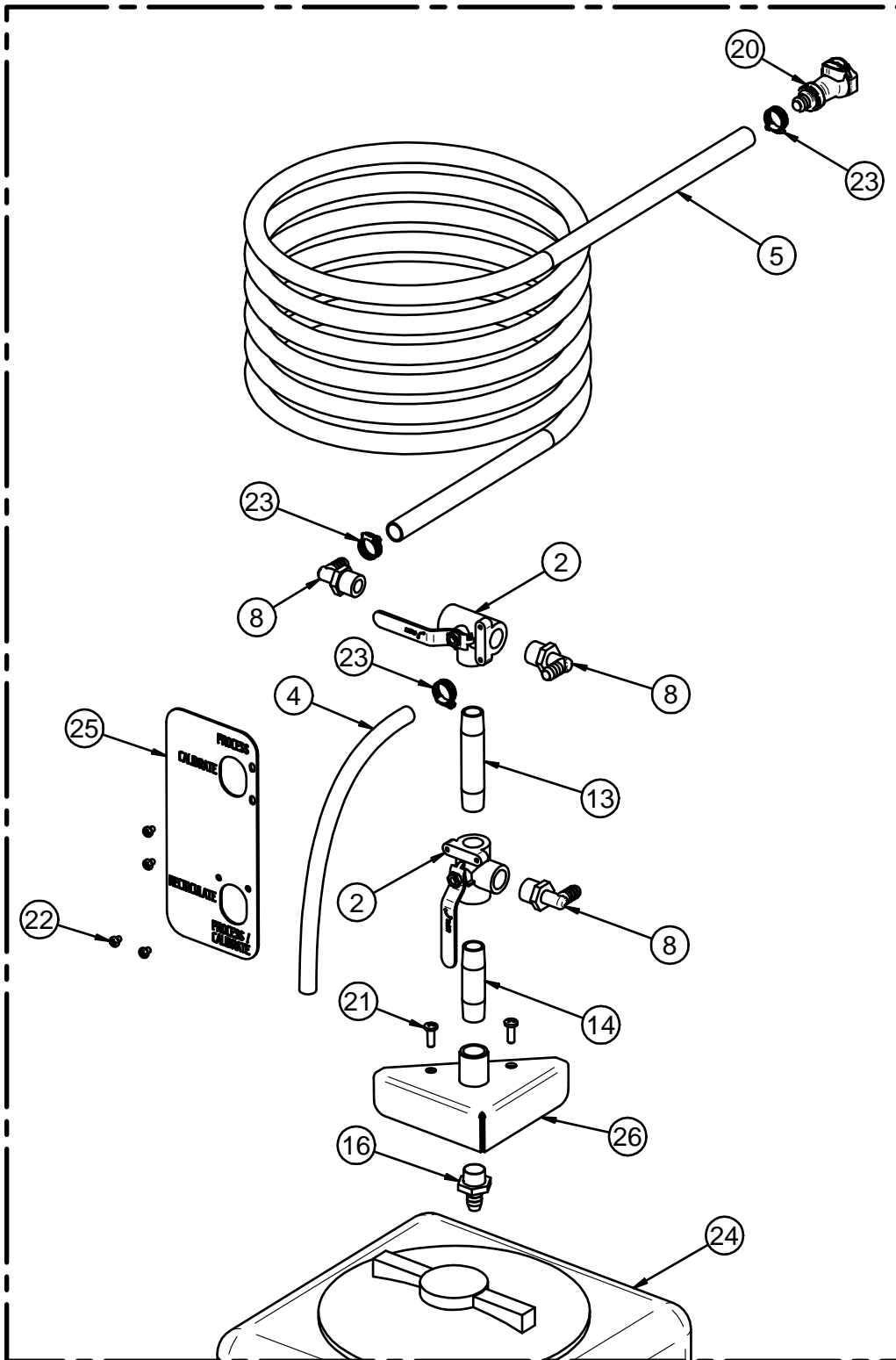

DETAIL A

TREATMENT TANK 2 (LEFT) ASSEMBLY (04-03-0295)

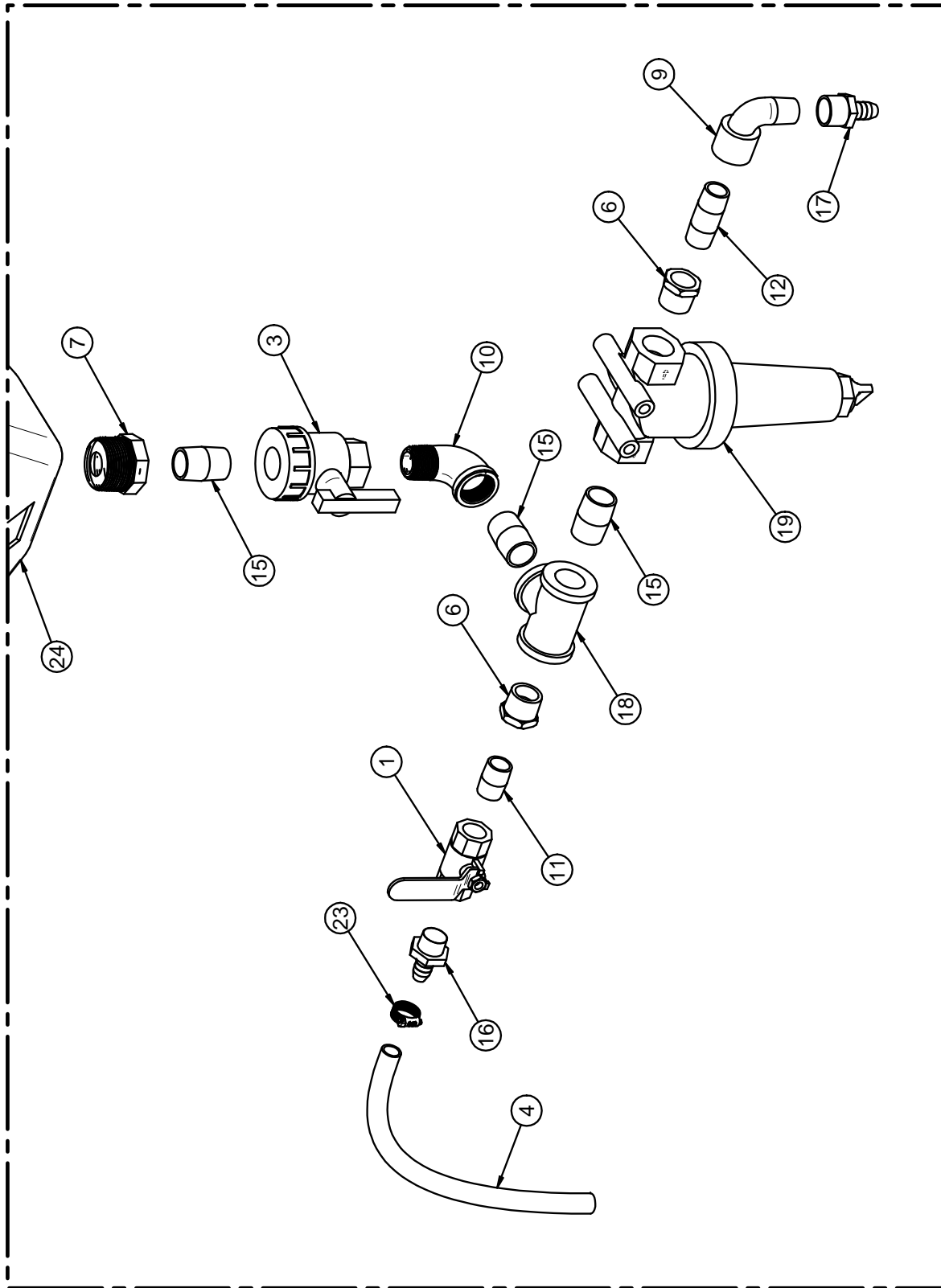

DETAIL B

TREATMENT TANK 2 (LEFT) ASSEMBLY (04-03-0295)

Item #	Part #	Description	Qty
1	02-02-0006	.500-14 NPT X 2-WAY VALVE	1
2	02-02-0007	VLV BALL .500 NPT 3WAY BRSS	2
3	02-02-0056	VLV BALL .750 NPT FM PLAS	1
4	02-03-0005	DRAIN HOSE PUMP STAND	2
5	02-03-0005	TUBE .50 RNT	1
6	02-04-0008	FTTG BUSH .750NPT X .500NPT SS	2
7	02-04-0051	FTTG BUSH 1.25 X .75 PVC	1
8	02-06-0010	FTTG 90 DEG .500HB X .500NPT ML NYL	3
9	02-06-0017	FTTG 90 DEG STRT .500NPT PPE BLK	1
10	02-06-0068	FTTG 90 DEG STRT .75NPT PPE BLK	1
11	02-07-0007	FTTG NIP .500NPTX1.125 TBE SS CLOSE	1
12	02-07-0010	FTTG NIP .500 NPT X 2.00 TBE SS	1
13	02-07-0013	FTTG NIP .500 NPT X 4.00 TBE SS	1
14	02-07-0019	FTTG NIP .500 NPT X 3.00 TBE SS	1
15	02-07-0070	FTTG NIP .750 NPT X 1.50 TBE SS	3
16	02-08-0007	FTTG STGHT .500HB X .500NPT ML NYL	2
17	02-08-0026	FTTG STGHT .500HB X .500NPT FM NYL	1
18	02-09-0008	FTTG TEE .750 NPT FM SS	1
19	02-12-0011	FLTR TEE PPE .750 NPT 16 MESH BANJO	1
20	02-15-0013	FTTG CPLG .500 HB QCK DISC BODY	1
21	06-01-0215	SCRW MACH #14 X .750 SS PLASTITE	2
22	06-06-0008	SCRW MACH 10-24 X .250 PHLP PHD ZP	4
23	06-07-0006	CLMP HOSE .500 TO .906 X .313W ZP	4
24	07-02-0041	TNK 10GAL POLY SQUARE	1
25	1054C1	VLV LBL	1
26	1054C3	WDMT VALVE MNT PLT	1

AT500H DUAL PUMP STAND ASSEMBLY (13-05-0575)

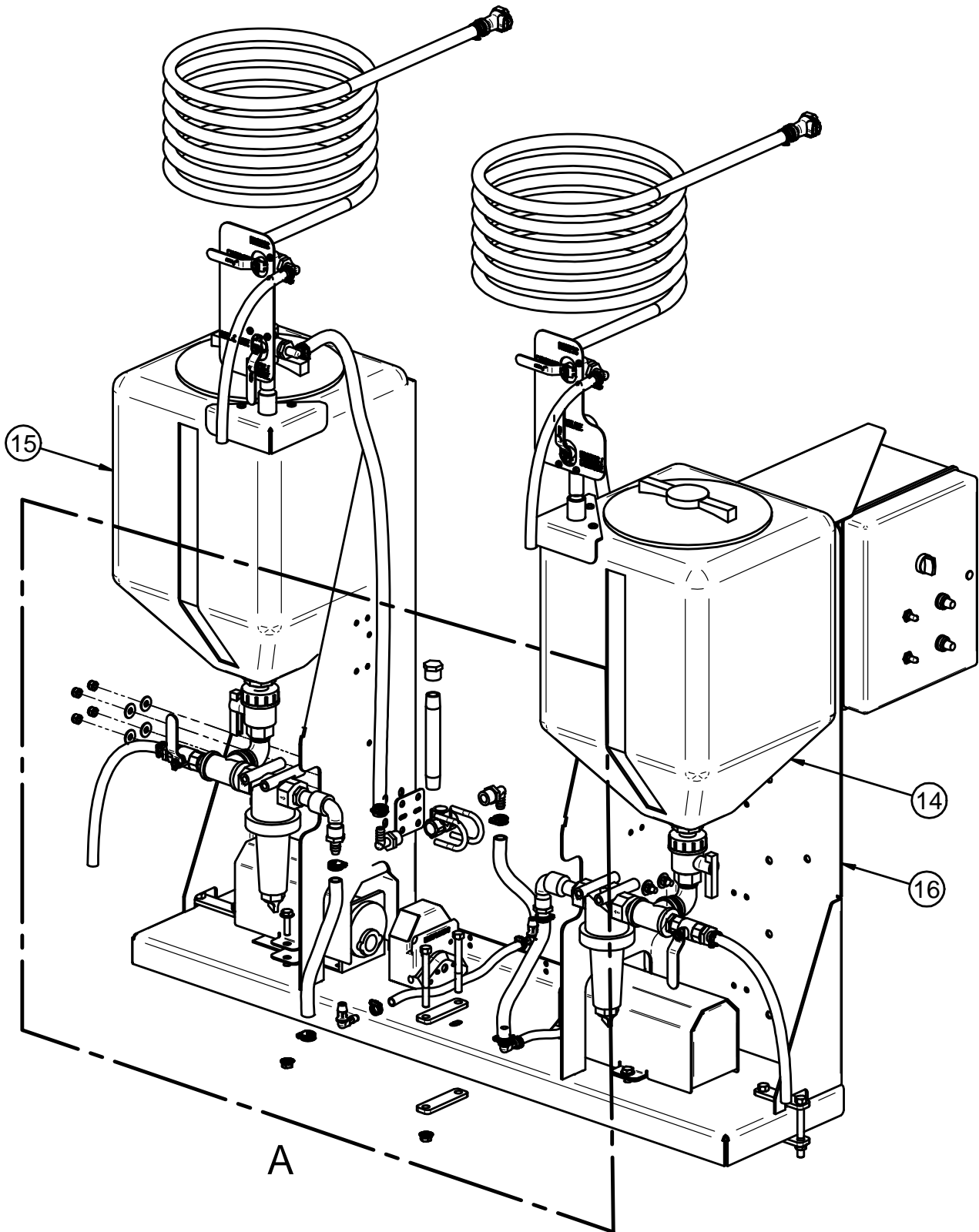

AT500H DUAL PUMP STAND ASSEMBLY (13-05-0575)

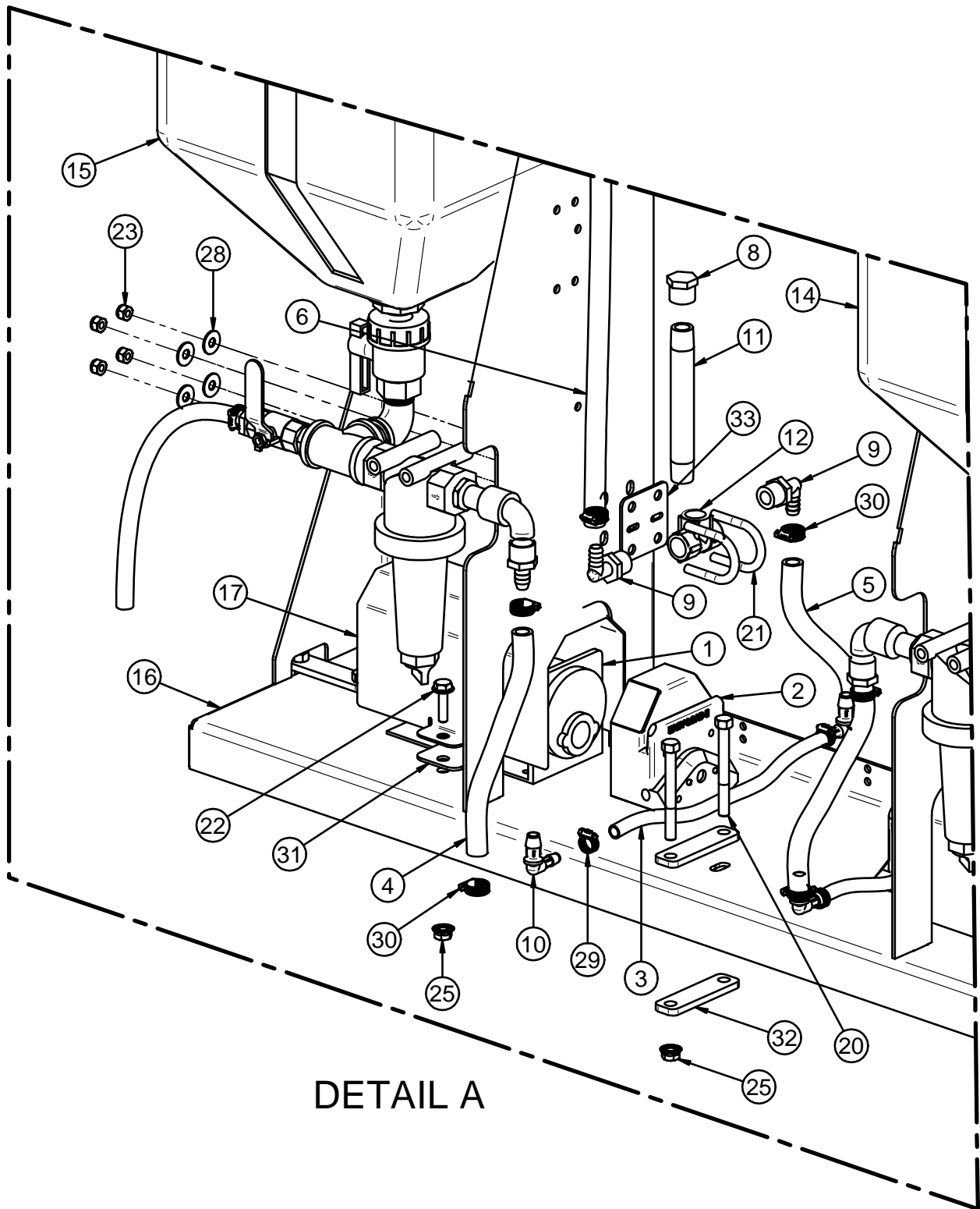

AT500H DUAL PUMP STAND ASSEMBLY (13-05-0575)

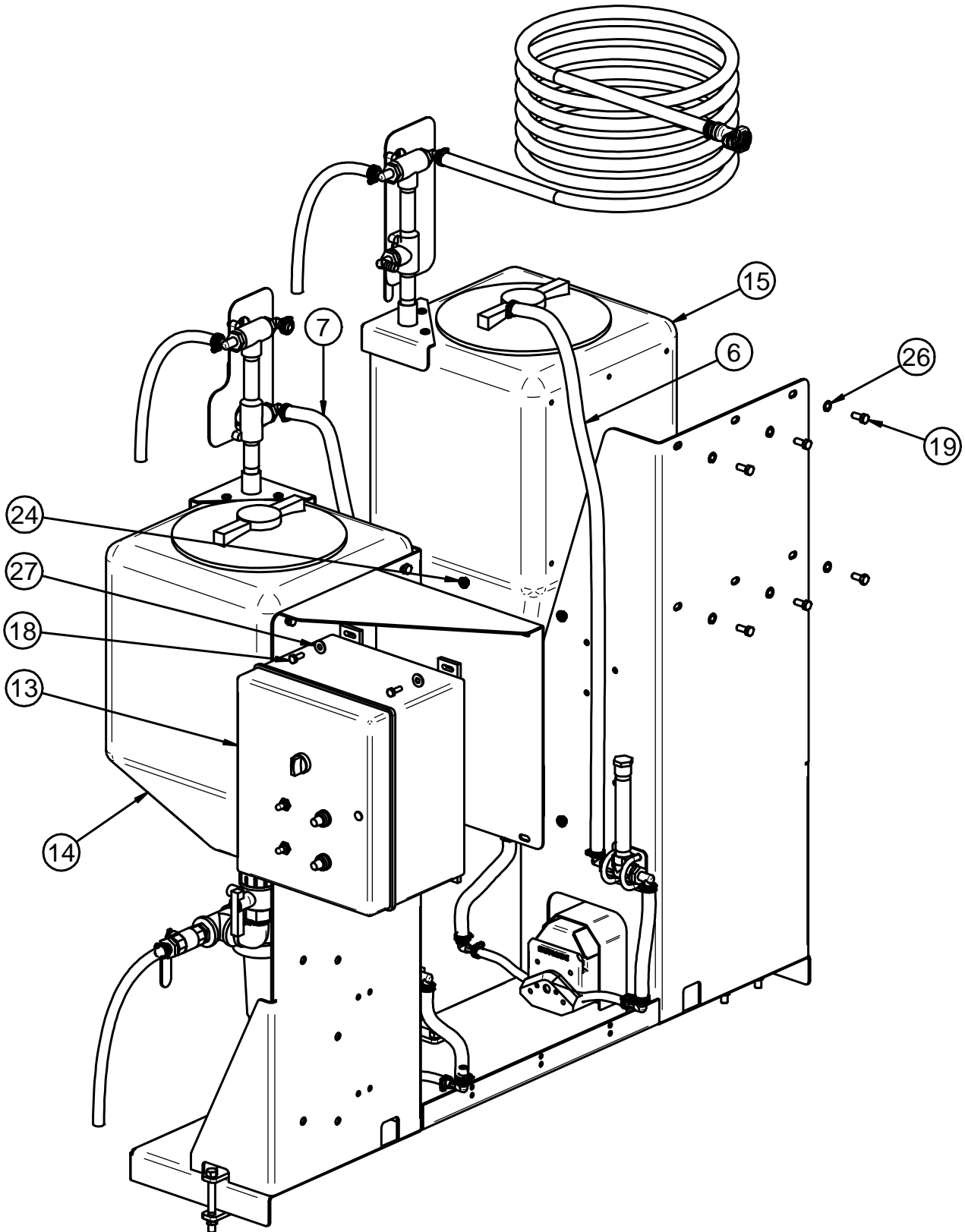

AT500H DUAL PUMP STAND KIT

AT500H DUAL PUMP STAND ASSEMBLY (13-05-0575)

Item #	Part #	Description	Tube Length	Qty
1	01-01-0010	MTR .1HP 6-600RPM 90VDC		2
2	02-01-0005	PUMP HEAD PRST MF LS 115V 600RPM		2
3	02-03-0001	HOSE MF .375 NPRN BLK - LS35 .31 ID	12 3/32 in	2
4	02-03-0005	TUBE .50 RNT	8 11/16 in	2
5	02-03-0005	TUBE .50 RNT	7 3/32 in	2
6	02-03-0005	TUBE .50 RNT	35 27/32 in	1
7	02-03-0005	TUBE .50 RNT	35 11/16 in	1
8	02-05-0086	FTTG END CAP .500 NPT BP		2
9	02-06-0010	FTTG 90 DEG .500HB X .500NPT ML NYL		4
10	02-06-0076	FTTG 90 DEG .500HB X .375HB NYL		4
11	02-07-0060	FTTG NIP .500 NPT X 6.00 TBE PVC		2
12	02-09-0005	FTTG TEE .500 NPT PPE		2
13	03-12-0536	PNL CNTL MNL 2 PUMP STATION		1
14	04-03-0294	ASSY AT500 TANK 1		1
15	04-03-0295	ASSY AT500 TANK 2		1
16	05-03-1687	WDMT AT500 PUMP FRM		1
17	05-06-0101	WDMT PUMP MTR COVER		2
18	06-01-0006	BOLT .250-20 X .750 ZP GR5		4
19	06-01-0010	BOLT .313-18 X .750 ZP GR5		12
20	06-01-0022	BOLT .375-16 X 3.50 ZP GR5		6
21	06-01-0037	BOLT U .313-18 X 1.38 X 2.188 ZP		4
22	06-01-0189	BOLT FLG .375-16 X 1.250 ZP GR5		4
23	06-03-0002	NUT NYL LOCK .313-18 ZP GR5		8
24	06-03-0013	NUT,LOCK, FLG .250-20 ZP SERRATTED		4
25	06-03-0014	NUT LOCK FLG .375-16 ZP GR5		10
26	06-04-0002	WSHR LOCK SPLT .313 ZP		12
27	06-05-0001	WASHER, FLAT .250		4
28	06-05-0003	WSHR FLAT .313 ZP		8
29	06-07-0005	CLMP HOSE .219 TO .625 X .313W ZP		4
30	06-07-0006	CLMP HOSE .500 TO .906 X .313W ZP		12
31	102276	BRKT PUMP MOUNT PUMPSTD		2
32	1054C4	MNT CLAMP		6
33	105970	PLT TEE LOCATOR		2

AT500H DUAL PUMP STAND KIT

NOTES:

USC LIMITED WARRANTY

SECTION I

USC, LLC, (Manufacturer) warrants its seed treating equipment as follows:

1. **Limited Warranty:** Manufacturer warrants that the Products sold hereunder will be free from defects in material and workmanship for a period of 18 months from date of shipment. If the Products do not conform to this Limited Warranty during the warranty period, Buyer shall notify Manufacturer in writing of the claimed defects and demonstrate to Manufacturer satisfaction that said defects are covered by this Limited Warranty. If the defects are properly reported to Manufacturer within the warranty period, and the defects are of such type and nature as to be covered by this warranty, Manufacturer shall, at its expense, furnish replacement Products or, at Manufacturer's option, replacement parts for the defective products. Shipping and installation of the replacement Products or replacement parts shall be at the Buyer's expense.

2. **Other Limits:** THE FOREGOING IS IN LIEU OF ALL OTHER WARRANTIES, EXPRESSED OR IMPLIED, INCLUDING BUT NOT LIMITED TO THE IMPLIED WARRANTIES OF MERCHANTABILITY AND FITNESS FOR A PARTICULAR PURPOSE. Manufacturer does not warrant against damages or defects arising from improper installation (where installation is by persons other than Manufacturer), against defects in products or components not manufactured by Manufacturer, or against damages resulting from such non-Manufacturer made products or components. Manufacturer passes on to the Buyer the warranty it received (if any) from the maker of such non-Manufacturer made products or components. This warranty also does not apply to Products upon which repairs and / or modifications have been effected or attempted by persons other than pursuant to written authorization by Manufacturer. This includes any welding on equipment which could damage electrical components. Manufacturer does not warrant against casualties or damages resulting from misuse and / or abuse of Products, improper storage or handling, acts of nature, effects of weather, including effects of weather due to outside storage, accidents, or damages incurred during transportation by common carrier.

3. **Exclusive Obligation:** THIS WARRANTY IS EXCLUSIVE. The sole and exclusive obligation of Manufacturer shall be to repair or replace the defective Products in the manner and for the period provided above. Manufacturer shall not have any other obligation with respect to the Products or any part thereof, whether based on contract, tort, strict liability or otherwise. Under no circumstances, whether based on this Limited Warranty or otherwise, shall Manufacturer be liable for lost profits, lost revenue, lost sales (whether direct or indirect damages), incidental, special, punitive, indirect or consequential damages.

4. **Other Statements:** Manufacturer's employees or representatives' oral or other written statements do not constitute warranties, shall not be relied upon by Buyer, and are not a part of the contract for sale or this limited warranty.

5. **Return Policy:** Approval is required prior to returning goods to Manufacturer. A restocking fee will apply.

6. **Entire Obligation:** This Limited Warranty states the entire obligation of Manufacturer with respect to the Products. If any part of this Limited Warranty is determined to be void or illegal, the remainder shall remain in full force and effect.

US / Canada Non-Exclusive 2016



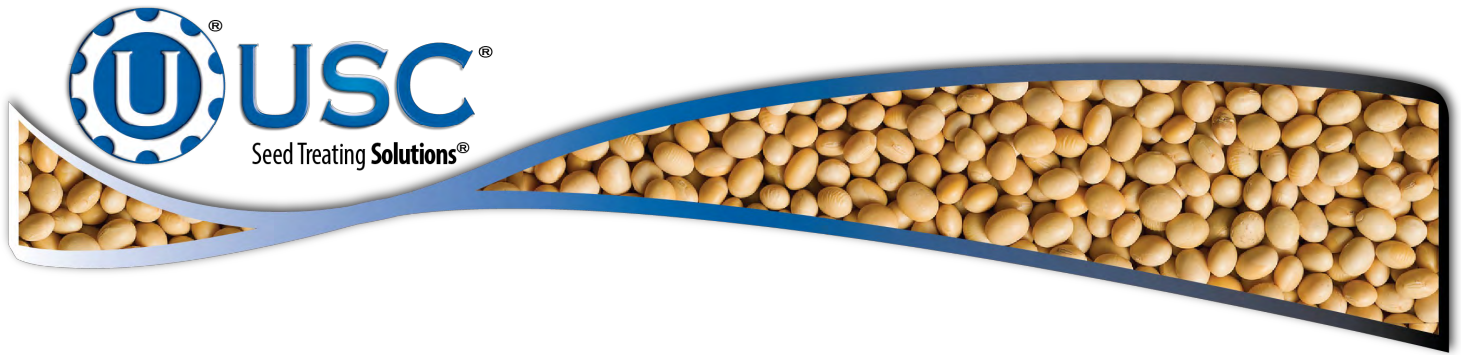

USC, LLC

2320 124th road

Sabetha, KS 66534

PHONE: (785) 431-7900

FAX: (785) 431-7950

EMAIL: sales-team@uscllc.com

WEB: www.uscllc.com

