



U-MAXX 900™

Introducing USC's most innovative high capacity seed tender.

Designed for versatility and durability, the U-Maxx 900™ features a 20' articulated, hydraulic discharge conveyor with a 180° swing and an extremely compact design for its large capacity. U-Maxx 900™ offers the maximum 900 unit storage capacity.



Advantages:

- 1125 cu. ft. total storage capacity for large jobs
- Three 300 unit hoppers or six 150 unit hopper configurations available
- Remote control operated for precision placement
- Rollover tarp standard – optional automatic tarp available
- TS2500 Cleated belt load out conveyor
- Air gates



***Now Accepting Orders
for Fall 2016 Delivery!***



INDUSTRY LEADER. INDUSTRY INNOVATOR.

2320 124th Rd. | Sabetha, Kansas 66534 | 866.729.1623 | www.USCLLC.com

U-MAXX 900™

Features & Benefits:

- Two available hopper configurations: three 300-unit or six 150-unit hoppers
- Manually selected air gates have 8" discharge and are controlled individually
- Remote control operation
- Comes standard with rollover tarp – automatic tarp option available
- 20' discharge conveyor with 180 degree swing
- 20hp Honda engine

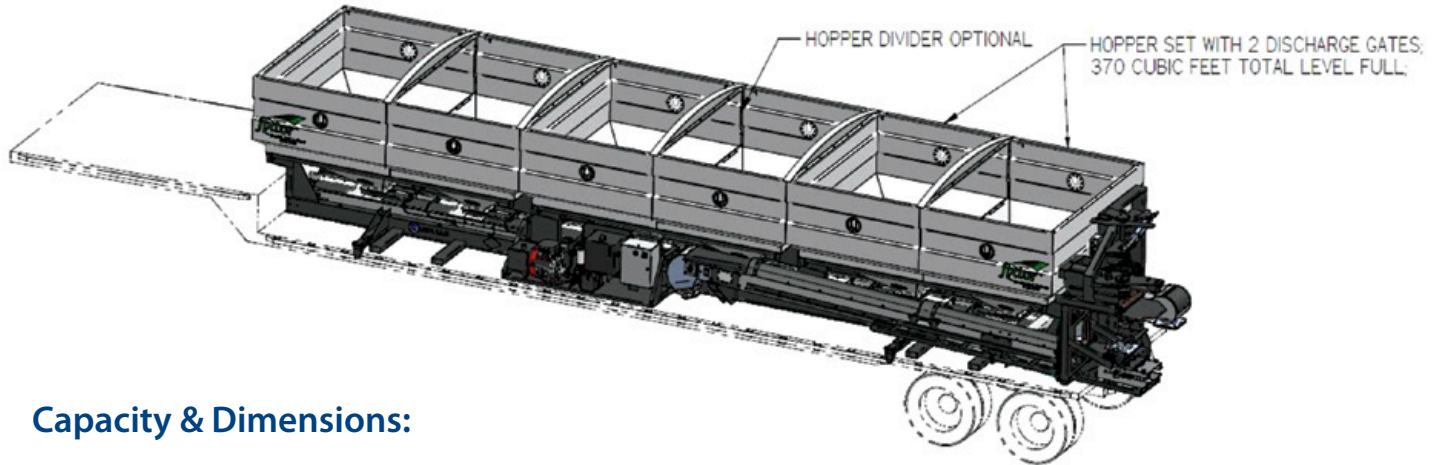

Capacity & Dimensions:

- 1125 cu. ft. capacity
- 10' high (with trailer)
- Recommended trailer requirements: 37' drop deck

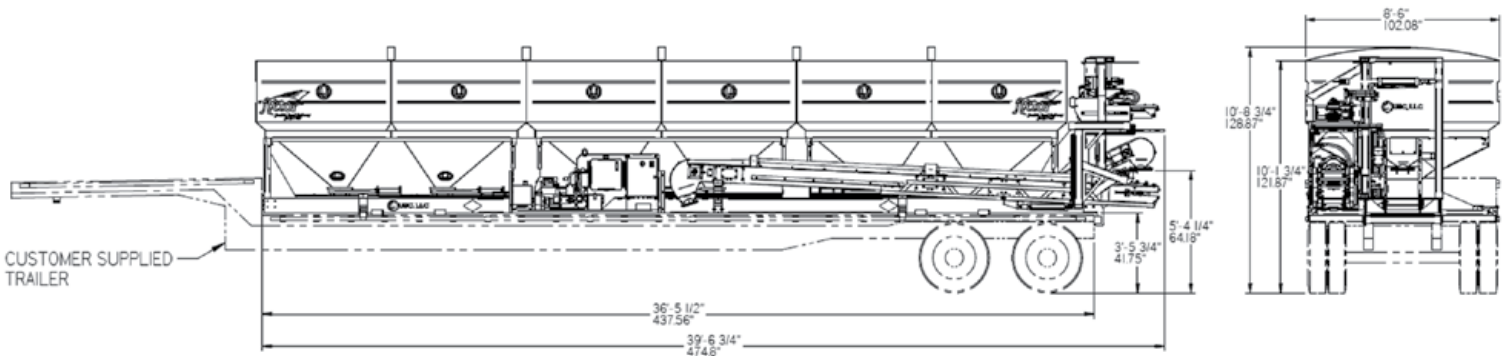

866.729.1623
www.USCLLC.com

Watch USC
Products
In Action!

