



# AT1000 SEED TREATER



## *Operator's Manual*



# **INTRODUCTION**

Thank you for choosing USC, LLC for your equipment needs. We appreciate your business and will work diligently to ensure that you are satisfied with your choice.

## **OVERVIEW**

The purpose of this manual is to provide you with the basic information needed to operate and maintain the AT1000. It does not hold USC, LLC liable for any accidents or injuries that may occur.

## **OPERATOR RESPONSIBILITIES**

As the purchaser/owner/operator of this equipment and control system, you have an obligation to install, operate, and maintain the equipment in a manner that minimizes the exposure of people in your care to any potential hazards inherent in using this equipment. It is critical that the owner of this equipment:

- Has a clear and documented understanding of the process this machine is being used in and of any resulting hazards or special requirements arising from this specific application.
- Allow only properly trained and instructed personnel to install, operate, or service this equipment.
- Maintain a comprehensive safety program involving all who work with this machine and other associated process equipment.
- Establish clear areas of staff responsibility (e.g. operation, setup, sanitation, maintenance, and repairs).
- Provide all personnel with necessary safety equipment.
- Periodically inspect the equipment to insure that the doors, covers, guards, and safety devices are in place and functioning, that all safety instructions and warning labels are intact and legible, and that the equipment is in good working order.
- In addition to the operating instructions, observe and enforce the applicable legal and other binding regulations, national and local codes.

As the person with the most to gain or lose from working safely, it is important that you work responsibly and stay alert. By following a few simple rules, you can prevent an accident that could injure or kill you or a co-worker.

- Do not operate, clean, or service this equipment until you have read and understood the contents of this manual. If you do not understand the information in this manual, bring it to the attention of your supervisor, or call your local USC dealer for assistance.
- Any operator who is known or suspected to be under the influence of alcohol or drugs should not be allowed to operate the equipment.
- Understand and follow the safety practices required by your employer and this manual.
- **PAY ATTENTION** to what you and other personnel are doing and how these activities may affect your safety.
- **Failure to follow these instructions may result in serious personal injury or death.**

### **RECEIVING YOUR EQUIPMENT**

As soon as the equipment is received, it should be carefully inspected to make certain that it has sustained no damage during shipment and that all items listed on the packing list are accounted for. If there is any damage or shortages, the purchaser must immediately notify your USC dealer. Ownership passes to purchaser when the unit leaves the USC, LLC. premises. The purchaser is responsible for unloading and mounting all components of the equipment.

Document the serial number of the machine for future reference. The serial number is located on the inside door of the main control panel.

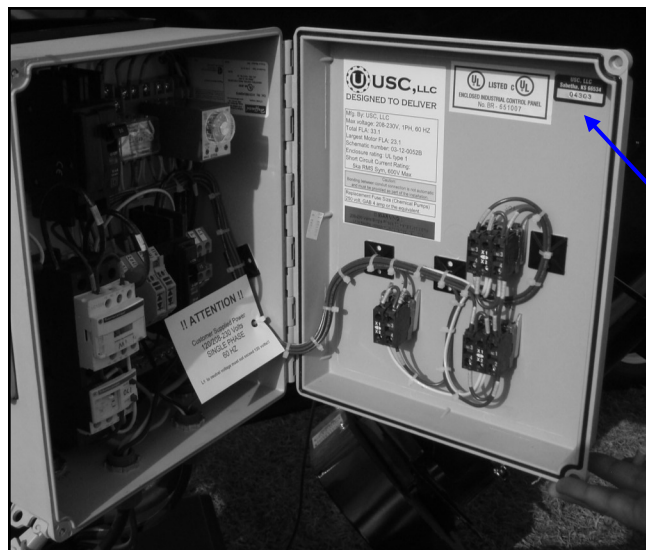

*Serial  
Number*

**SERIAL NUMBER:** \_\_\_\_\_

# TABLE OF CONTENTS

<u>Section</u>	<u>Contents</u>	<u>Page #</u>
<b>Section A</b>	<b>Safety Instructions .....</b>	<b>5</b>
<b>Section B</b>	<b>Installation .....</b>	<b>12</b>
<b>Section C</b>	<b>Mechanical Operation .....</b>	<b>14</b>
	System Overview .....	14
	Supply Hopper .....	15
	Liquid System.....	15
	Auger.....	16
<b>Section D</b>	<b>Electrical Operation .....</b>	<b>18</b>
<b>Section E</b>	<b>Calibration .....</b>	<b>20</b>
	Seed Flow Calibration .....	20
	Chemical Pump Calibration.....	22
	Changing Nozzle Sizes .....	23
	Pump Charts .....	24
	Treating Seed.....	25
<b>Section F</b>	<b>Troubleshooting .....</b>	<b>26</b>
	Proximity Switch Adjustment Guide.....	27
<b>Section G</b>	<b>Maintenance .....</b>	<b>28</b>
<b>Section H</b>	<b>Storage.....</b>	<b>29</b>
<b>Section I</b>	<b>Mechanical Drawings.....</b>	<b>31</b>
<b>Section J</b>	<b>Limited Warranty .....</b>	<b>41</b>

# SAFETY INSTRUCTIONS

## SECTION A

Every year accidents in the work place maim, kill, and injure people. Although it may be impossible to prevent all accidents, with the right combination of training, operating practices, safety devices, and operator vigilance, the number of accidents can be significantly reduced. The purpose of this section is to educate equipment users about hazards, unsafe practices, and recommended hazard avoidance techniques.

### SAFETY WORDS AND SYMBOLS

It is very important that operators and maintenance personnel understand the words and symbols that are used to communicate safety information. Safety words, their meaning and format, have been standardized for U.S. manufacturers and published by the American National Standards Institute (ANSI). The European Community (E.C.) has adopted a different format based on the International Standards Organization (I.S.O.) and applicable machinery directives. Both formats are presented below. Graphic symbols are not standardized, but most manufacturers will use some variation of the ones seen in this manual.



Indicates an imminently hazardous situation which, if not avoided, **will** result in death or serious injury.



Indicates a potentially hazardous situation which, if not avoided, **could** result in death or serious injury.



Indicates a potentially hazardous situation which, if not avoided, **may** result in minor or moderate injury and/or property damage.



Provides additional information that the operator needs to be aware of to avoid a potentially hazardous situation.



**Mandatory Lockout Power Symbol.** Disconnect, lockout, and tagout electrical and other energy sources before inspecting, cleaning, or performing maintenance on this panel.



**International Safety Alert Symbol.** The exclamation point (!) surrounded by a yellow triangle indicates that an injury hazard exists. However, it does not indicate the seriousness of potential injury. The exclamation point (!) is also used with the DANGER, WARNING, and CAUTION symbols so the potential injury is indicated.



**Electrocution Hazard Symbol.** This symbol indicates that an electrocution hazard exists. Serious injury or death could result from contacting high voltage.



**International Electrocution Hazard.** This symbol indicates that an electrocution hazard exists. Serious injury or death could result from contacting high voltage.



**Mandatory Read Manual Action Symbol.** (I.S.O. format)  
This symbol instructs personnel to read the Operators Manual before servicing or operating the equipment.



**Mandatory Read Manual Action Symbol.** This symbol instructs personnel to read the Operators Manual before servicing or operating the equipment.



Notice is used to notify people of important installation, operation, or maintenance information which is not hazard related.

## **LOCKOUT / TAGOUT PROCEDURES**

Lockout/Tagout is the placement of a lock/tag on an energy isolating device in accordance with an established procedure. When taking equipment out of service to perform maintenance or repair work, always follow the lockout/tagout procedures as outlined in ANSI Z344.1 and/or OSHA Standard 1910.147. This standard “requires employers to establish a program and utilize procedures for affixing appropriate lockout devices or tagout devices to energy isolating devices and to otherwise disable machines or equipment to prevent unexpected energizing, start-up, or release of stored energy in order to prevent injury to employees.”

### **CONTROLLED STOP**

This is the stopping of machine motion by reducing the electrical command signal to 0 (zero) once the stop signal has been recognized.

### **HAZARD REVIEW**



#### **Electrocution Hazard**

Electrocution accidents are most likely to occur during maintenance of the electrical system or when working on or near exposed high voltage wiring.



This hazard does not exist when the electrical power has been disconnected, properly locked, and tagged out.



#### **Automatic Start Hazard**

This seed treating system is usually controlled by an automated system and may start without warning. Failure to properly disconnect, lockout, and tagout all energy sources of remotely controlled equipment creates a very hazardous situation and could cause injury or even death. PLEASE STAY CLEAR AND BE ALERT.



**YOU** are responsible for the **SAFE** operation and maintenance of your USC, LLC Seed Treating System. **YOU** must ensure that you and anyone else who is going to operate, maintain, or work around the Seed Treating System be familiar with the operating and maintenance procedures and related **SAFETY** information contained in this manual. This manual will take you step-by-step through your working day and alert you to good safety practices that should be adhered to while operating the Seed Treating System.

Remember, **YOU** are the key to safety. Good safety practices not only protect you, but also the people around you. Make these practices a working part of your safety program. Be certain that **EVERYONE** operating this equipment is familiar with the recommended operating and maintenance procedures and follows all the safety precautions. Most accidents can be prevented. Do not risk injury or death by ignoring good safety practices.

- AT Series Seed Treater owners must give operating instructions to operators or employees before allowing them to operate the machine, and at least annually thereafter per OSHA (Occupational Safety and Health Administration) regulation 1928.57.
- The most important safety device on this equipment is a **SAFE** operator. It is the operator's responsibility to read and understand **ALL** Safety and Operating instructions in the manual and to follow them. All accidents can be avoided.
- A person who has not read and understood all operating and safety instructions is not qualified to operate the machine. An untrained operator exposes himself and bystanders to possible serious injury or death.
- Do not modify the equipment in any way. Unauthorized modification may impair the function and/or safety and could affect the life of the equipment.
- Think SAFETY! Work SAFELY!

### GENERAL SAFETY

1. Read and understand the Operator's Manual and all safety signs before operating, maintaining, adjusting or unplugging the AT Series Seed Treater.
2. Only trained persons shall operate the seed treater. An untrained operator is not qualified to operate the machine.
3. Have a first-aid kit available for use should the need arise, and know how to use it.





4. Provide a fire extinguisher for use in case of an accident. Store in a highly visible place.
5. Do not allow children, spectators or bystanders within hazard area of machine.
6. Wear appropriate protective gear. This includes but is not limited to:

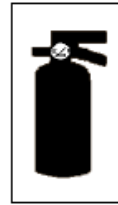

- A hard hat
- Protective shoes with slip resistant soles
- Protective goggles
- Heavy gloves
- Hearing protection
- Respirator or filter mask



7. Place all controls in neutral or off, stop motor, and wait for all moving parts to stop. Then disable power source before servicing, adjusting, repairing, or unplugging.



8. Review safety related items annually with all personnel who will be operating or maintaining the AT Series Seed Treater.

### **OPERATING SAFETY:**

1. Read and understand the Operator's Manual and all safety signs before using.
2. Disconnect and disable electrical supply completely and wait for all moving parts to stop before servicing, adjusting, repairing or unplugging.
3. Clear the area of bystanders, especially children, before starting.
4. Be familiar with the machine hazard area. If anyone enters hazard area, shut down machine immediately. Clear the area before restarting.
5. Keep hands, feet, hair and clothing away from all moving and/or rotating parts.
6. Stay away from overhead obstructions and power lines during operation and transporting. Electrocution can occur without direct contact.
7. Do not operate machine when any guards are removed.
8. Inspect welds and repair if needed.

### **PLACEMENT SAFETY**

1. Move only with the appropriate equipment
2. Stay away from overhead power lines when moving the Seed Treating System. Electrocution can occur without direct contact.
3. Be familiar with machine hazard area. If anyone enters hazard areas, shut down machine immediately. Clear the area before restarting.
4. Operate the Seed Treater on level ground free of debris. Anchor the Seed Treater to prevent tipping or upending.



Before placement of the Seed Treater, be sure that ground is reasonably level. The Seed Treater may topple or work improperly if the ground is too uneven, damaging the equipment and/or causing personal injury.

### **MAINTENANCE SAFETY**

1. Review the Operator's Manual and all safety items before working with, maintaining or operating the Seed Treating System.
2. Place all controls in neutral or off, stop motors, disable power source, and wait for all moving parts to stop before servicing, adjusting, repairing or unplugging.
3. Follow good shop practices:  
Keep service area clean and dry.  
Be sure electrical outlets and tools are properly grounded.  
Use adequate light for the job at hand.
4. Keep hands, feet, hair and clothing away from all moving and/or rotating parts.
5. Clear the area of bystanders, especially children, when carrying out any maintenance and repairs or making any adjustments.
6. Before resuming work, install and secure all guards when maintenance work is completed.
7. Keep safety signs clean. Replace any sign that is damaged or not clearly visible.



## **SAFETY SIGNS**

1. Keep safety signs clean and legible at all times.
2. Replace safety signs that are missing or have become illegible.
3. Replaced parts that displayed a safety sign should also display the current sign.
4. Safety signs are available from your Authorized Dealer.

### **How to Install Safety Signs:**

- Be sure that the installation area is clean and dry.
- Be sure temperature is above 50°F (10°C).
- Decide on the exact position before you remove the backing paper.
- Remove the smallest portion of the split backing paper.
- Align the sign over the specified area and carefully press the small portion with the exposed sticky backing in place.
- Slowly peel back the remaining paper and carefully smooth the remaining portion of the sign in place.
- Small air pockets can be pierced with a pin and smoothed out using the piece of sign backing paper.



Located on the USC equipment you will find safety labels.  
Always be sure to read and follow all directions on the labels.



**SECTION  
B**

**INSTALLATION**



**HIGH VOLTAGE** ~ Always disconnect the power source before working on or near the control panel or lead wires.



**HIGH VOLTAGE** ~ Use insulated tools when making adjustments while the controls are under power.

**NOTICE**

Permanent installation may require additional electrical cords, liquid hose, and air lines, since each installation is unique.

**SET-UP**

The following steps outline the initial set-up of the AT1000:

1. Clear the area of bystanders, especially small children, before moving.
2. Place the AT1000 in the desired position on a level surface.



Be sure there is enough clearance from overhead obstructions and power lines or other equipment to move the machine into its working position.



USC highly recommends that the equipment be stored inside a building or any covered structure to protect the machine from weathering.

3. Drop the front two legs of the machine to keep the treater stable during operation.



4. Inspect machine thoroughly for screws, bolts, fittings, etc. which may have come loose during shipping.
5. Check and tighten hose connections.

**NOTICE** Tubing may contain a non-freezable liquid from testing. Be sure to flush before operation.

6. Have a certified electrician provide power to the seed treating system. Provide convenient shutdown switches and comply with local electrical codes. The USC system must be connected to the same electrical requirements as specified in the main control panel on the power requirement tag (right), and the electrical schematic shipped with the piece of equipment. This will power the entire USC system.
7. Reverse the above procedure when removing the machine from its working position.

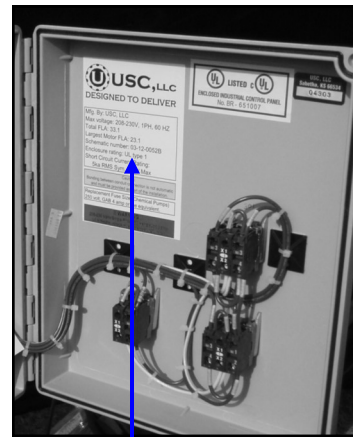

**Power Requirement Tag**

**SYSTEM OVERVIEW**

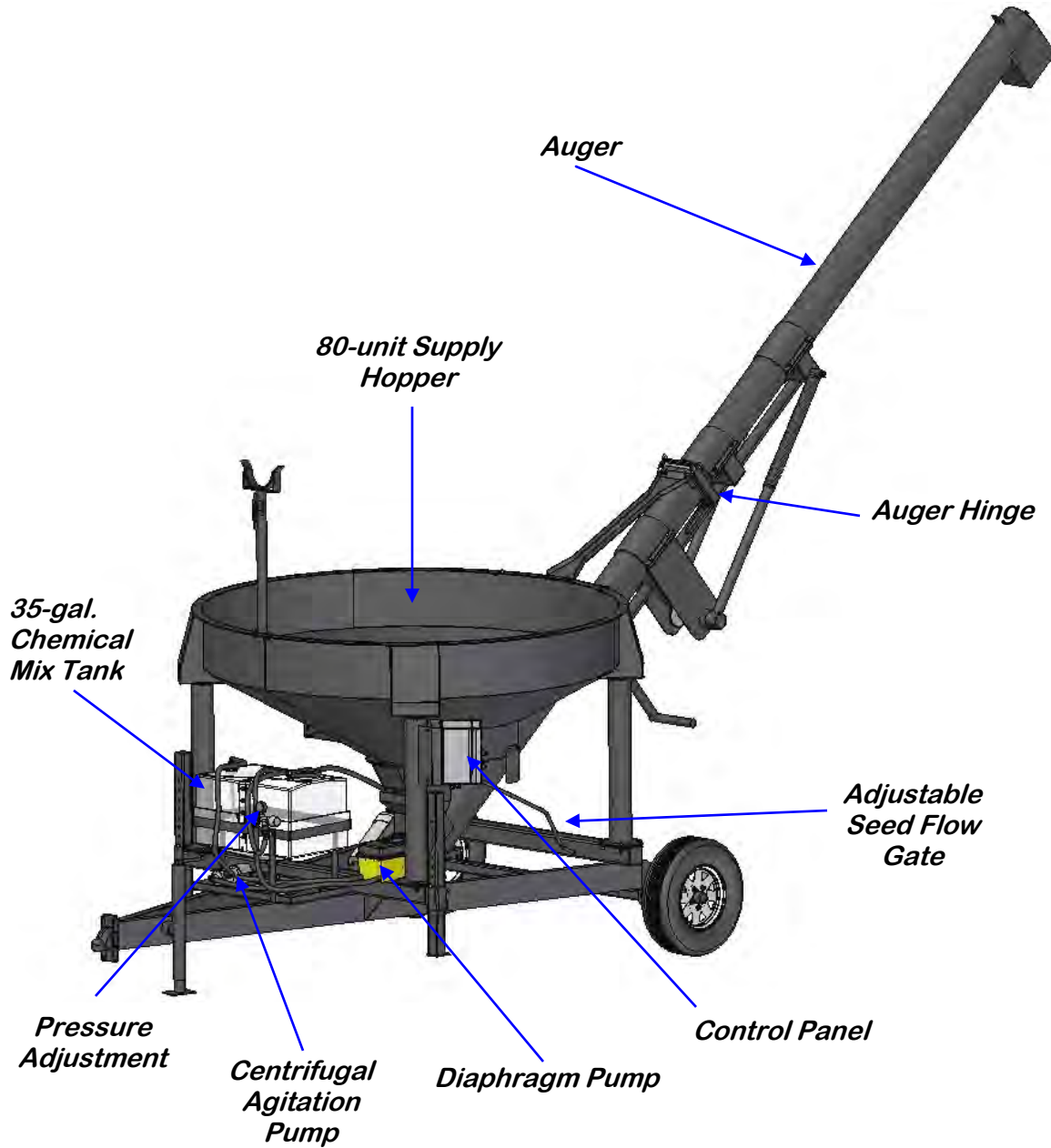

## **SUPPLY HOPPER**

The supply hopper has a capacity of approximately 80 units of seed. The hopper supplies seed to the spray chamber where seed first comes in contact with chemical.

The seed flow is controlled by an adjustable seed gate. Refer to “Section E: Calibration”, for instructions on adjusting the seed flow gate. Dry batch calibration runs will be required in order to determine the seed flow rate. Rates should be determined in Quantity/Time, this will allow for proper liquid/granular mixtures.

**NOTICE** Different seed types may be treated with this equipment. It is imperative to note that re-calibration of the seed gate setting will be required with each new seed type.

The supply hopper is also equipped with a proximity switch. The proximity switch controls the automatic shut-off of the chemical pump when the hopper runs out of seed. Refer to “Control Panel” in Section D, and Section F: Troubleshooting; “Proximity Switch Adjustment Guide” for more in-depth information on the proximity switch.

---

## **LIQUID SYSTEM**

The USC AT1000 Series seed treater is equipped with a 35-gallon mix tank with a centrifugal pump to keep chemicals mixed and in suspension. The agitator should be running at all times when chemical is present inside the tank. The tank is also equipped with a shut-off valve, drain valve, and filter which is located on the bottom of the tank.

The liquid system utilizes a diaphragm pump and pressure valve for chemical metering. Proper calibration of the liquid system is critical to achieve a proper granular/chemical mixture.

When treating is completed, empty the remaining chemical from the mix tank into a suitable container. Clean water should be pumped through the system.

**WARNING** Always dispose of chemical or diluted chemical according to your local, state, and federal regulations.

**NOTICE** Only you, the operator, can determine the length of time required to completely rinse all chemical residue from the tank and plumbing system.

**AUGER**

**NOTICE**

Never allow exposure of persons or clothing to the auger, belts, or the pulleys during operation. Always have the safety shields in place during operation.

The 20' auger accepts seed after it passes through the spray chamber. As seed passes through the length of the auger, it is mixed with the seed treatment, producing a uniform seed coating. The seed then exits the auger on the discharge end of the machine.

Use the diagram below to unfold auger.

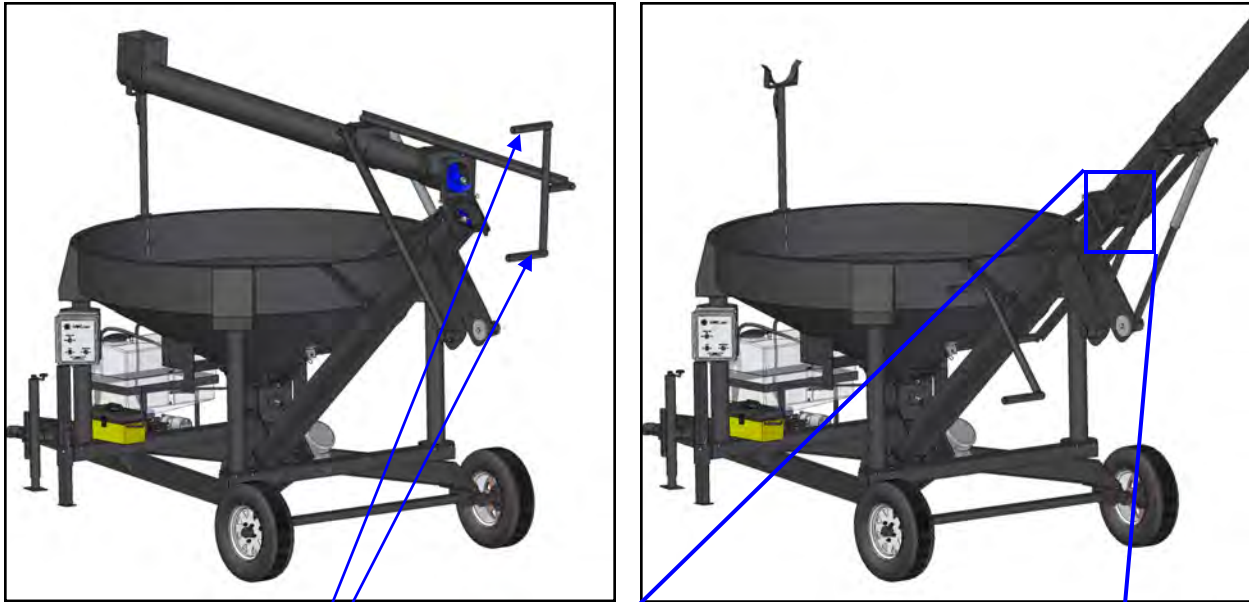

*Use these handles to unfold auger*

*Auger Latch holds auger in position*





AT1000

**NOTES**

A large empty rectangular box with a black border, intended for handwritten notes.

**SECTION  
D**

**ELECTRICAL OPERATION**



**HIGH VOLTAGE** ~ Always disconnect the power source before working on or near the control panel or lead wires.



**HIGH VOLTAGE** ~ Use insulated tools when making adjustments while the controls are under power.



**AUTHORIZED PERSONNEL** only shall work on the control panel. Never allow anyone who has not read and familiarized themselves with the owner's manual to open or work on the control panel.

**MAIN CONTROL PANEL**

Refer to the control panel and the electrical schematic for proper voltage and amperage of the machine.



**Controls Explained**

**1. Chemical Pump:**

- When the pump switch is turned to “Hand”, the pump will immediately begin running.
- When the switch is turned to “Auto”, the pump will activate only when the proximity switch located at the bottom of the supply hopper is covered. The proximity switch determines when seed is present in the hopper. When the proximity switch does not detect seed, a timer relay located inside the control panel will automatically shut off the pump(s) a pre-determined amount of time after the hopper has emptied. The timer relay (right) located in the control panel is set to Mode “D” and has an adjustable knob with settings from 0-6. Each number represents the number of seconds from the time the hopper empties until the pumps will shut off. The time delay allows all seed in the hopper to have an equal coverage.



**2. Auger:** This switch allows you the operator to turn the auger on or off.

**3. Agitation Pump:** This switch allows the operator to turn the chemical agitation pump on or off.

**Bottom of Control Panel**

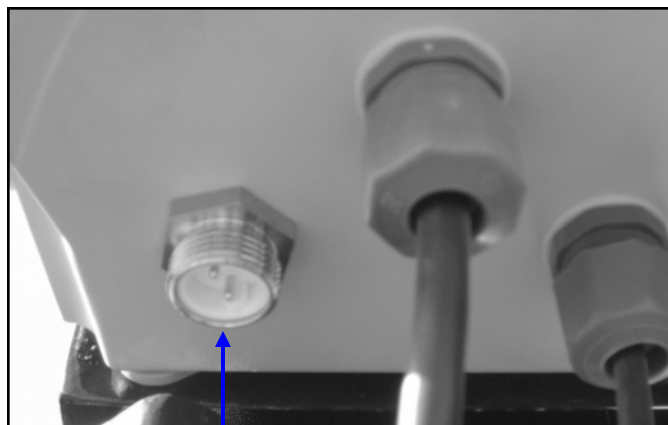

***Auxiliary Port***

SECTION  
E**CALIBRATION**

Calibration of both the seed flow and liquid portions of the equipment is necessary for accurate treatment of seed.

**NOTICE** If you prefer metric measurements, please refer to the conversion chart on page 25.

**SEED FLOW CALIBRATION**

The following steps illustrate how to calibrate the seed flow for an AT Series Seed Treater. A stop watch, ladder, and a know weigh of seed will be needed for the calibration process.

1. Position all equipment so that you are able to run a dry batch of seed through the seed treater and catch it back into a container. This will allow you to easily run the seed through again to recalibrate or begin treating. Calibration should be done with at least 2000 lbs. or 40 units.
2. Set the seed gate at a position that you and your equipment can handle. Refer to page 21 for adjusting the seed gate.
3. Fill the supply with the seed to be treated.
4. Place the auger and any conveyors in the "ON" position.
5. When equipment is in position, open up the seed gate all the way open until the clip hits the stop. Using the stop watch, begin timing as soon as gate is opened.

**NOTICE** Ensure the supply hopper stays full at all times. If seed does not pile-up in the hopper, the seed calibration will not be accurate.

6. Stop timing after all seed has left the supply hopper.
7. Calculate the seed flow rate: Total Pounds per Minute.

**EXAMPLE:** 2000 pounds takes 3 minutes and 18 seconds, or 198 seconds  
 $2000 \text{ pounds} / 198 \text{ seconds} = 10.1 \text{ pounds/seconds}$   
 $10.1 \times 60 \text{ seconds} = 606 \text{ lbs/minute}$   
 $606 / 100 = 6.06 \text{ cwt/min (hundred weight per minute)}$

**NOTICE** Different seed sizes and different seed types will tend to flow differently. Be sure to check calibration when changing to a different seed size or seed type.

**WARNING** Do not run the seed at a rate greater than 1000 pounds per minute. Running at a rate greater than 1000 pounds per minute could cause the auger motor to overload.

### **ADJUSTING THE SEED FLOW GATE**

To adjust the seed flow gate, move the clip to a desired seed flow adjustment hole. One of the middle holes is a good starting point. To open, rotate the gate crank to until the clip hits the stop, this will allow only a certain amount of seed to be fed into the auger. See diagram below for more details.

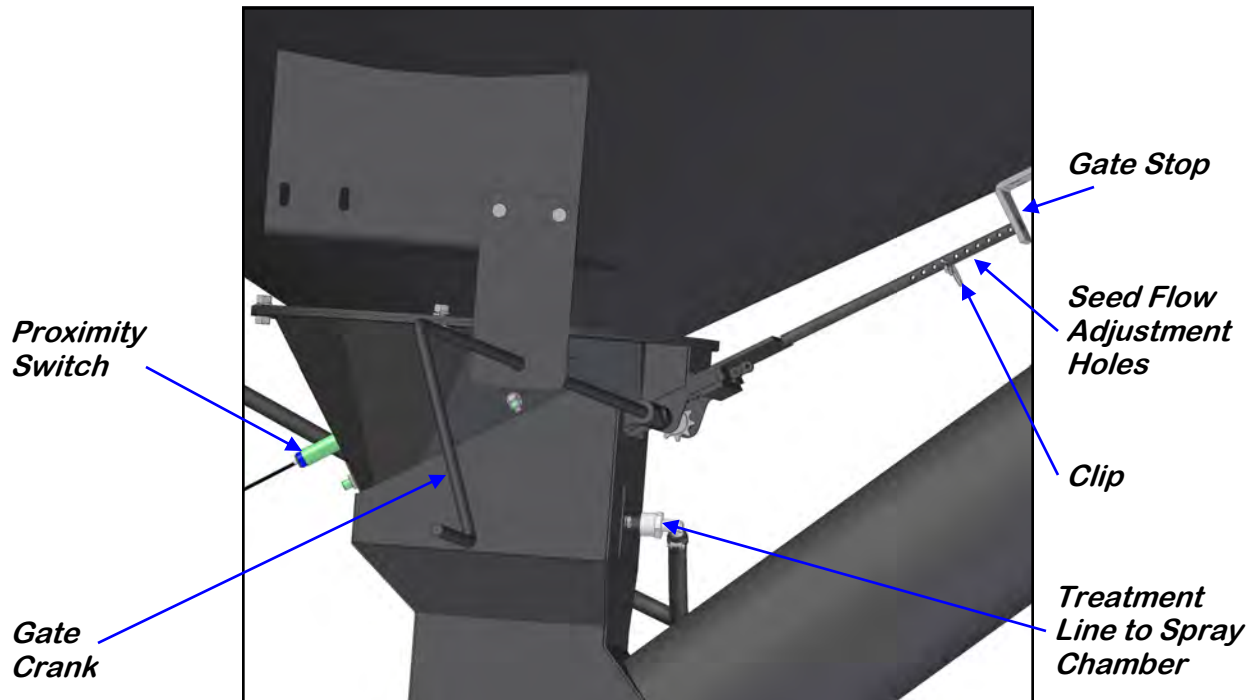

## CHEMICAL PUMP CALIBRATION

The following steps illustrate how to calibrate the chemical pump on an AT Series Seed Treater. A stop watch and measuring cup will be needed for the calibration process.

1. Premix enough liquid for the amount of seed you are treating and pour into the 35 gallon poly tank. It's always a good practice to mix up 20% extra slurry to help fill all the lines. Turn on the agitation pump and allow liquid to mix.
2. As the chemical is mixing, determine the number of ounces needed in one minute.

**EXAMPLE:** The seed treatment slurry rate is 10 ounces per cwt.  
 Seed Flow Rate = 6.06 cwt/min. x 10 oz./cwt. = 60.6 oz./min.  
 60.6 oz. is the rate the pump should be pumping in one minute.

3. Refer to the charts on page 24 for the approximate rate for each nozzle size available at the given pressures. In the above example, for a rate of 60.6 oz per minute, nozzle size TG-3 at approximately 26 psi would be the best option. Page 23 explains how to change nozzle sizes.
4. After the correct nozzle has been installed. Hold the spray nozzle over the measuring pitcher and turn the "CHEMICAL PUMP" switch to "HAND". Liquid should begin spraying into the measuring pitcher. Allow the pump to run until all air has been removed.
5. As the pump is running, set the desired pressure using the regulator valve (right).
6. After you have set the pressure and all air has been removed from the line, empty the remaining liquid in the measuring pitcher back into the mix tank.
7. Now you are ready to check liquid flow. Hold the spray nozzle over the measuring pitcher. Turn the "CHEMICAL PUMP" switch to "HAND". Using the stop watch, begin timing as soon as liquid begins spraying into the measuring pitcher.
8. As soon as one minute is up, turn the "CHEMICAL PUMP" switch to "OFF". Read the level on the side of the measuring cup. This number should equal the number of ounces needed to flow through the pump in one minute. If the ounces needed per minute have not been met, re-adjust the regulator valve up or down accordingly and repeat steps 7 & 8 until the liquid flow rate has been matched.



*Pressure Gauge and  
Regulator*

**CHANGING NOZZLE SIZES**

1. Remove the two bolts that secure the nozzle & plumbing into the spray chamber.

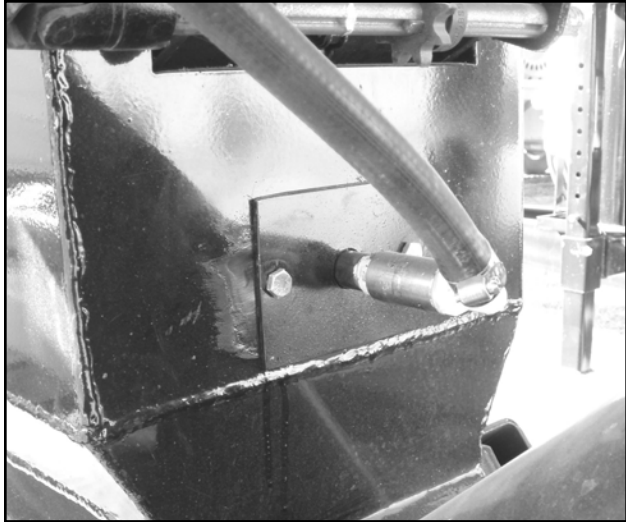

2. After the bolts have been removed, the spray chamber plumbing can be removed to access the nozzle. The nozzle unscrews from the spray chamber plumbing so it can be cleaned or changed.

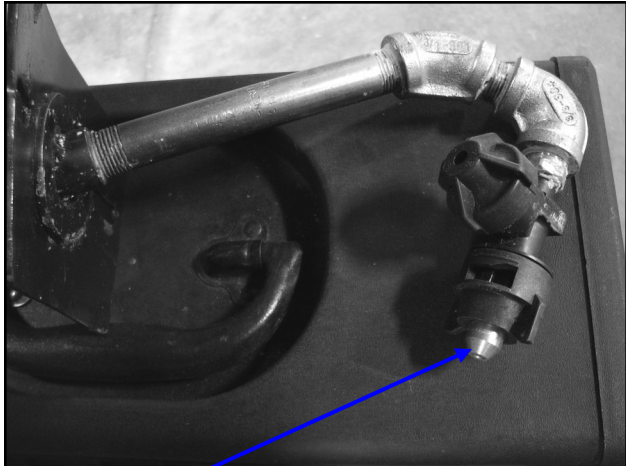

*Nozzle*

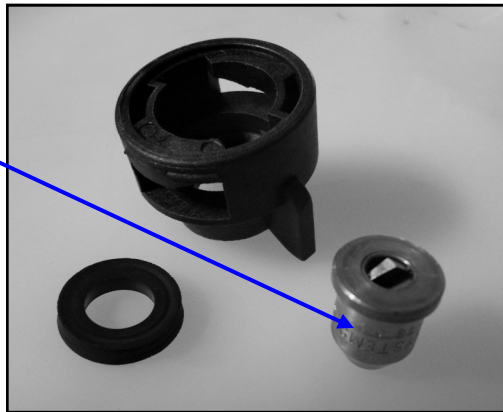

Below are two charts that show the potential flow rate at given nozzle size and psi.

**NOTICE** *All calibrations were done using water. Numbers are not exact; only use these numbers as a starting point or for troubleshooting.*

### Ounces per Minute

<u>Nozzle Size</u>	<u>psi</u>			
	<u>20</u>	<u>30</u>	<u>40</u>	<u>60</u>
<b>TG-1</b>	18	20	24	29
<b>TG-2</b>	36	42	49	59
<b>TG-3</b>	52	64	73	87
<b>TG-4</b>	70	84	97	116
<b>TG-6</b>	105	127	146	175

### Milliliters per Minute

<u>Nozzle Size</u>	<u>psi</u>			
	<u>20</u>	<u>30</u>	<u>40</u>	<u>60</u>
<b>TG-1</b>	532	592	710	858
<b>TG-2</b>	1065	1242	1449	1745
<b>TG-3</b>	1538	1893	2159	2573
<b>TG-4</b>	2071	2485	2869	3431
<b>TG-6</b>	3106	3757	4319	5177



AT1000

**TREATING SEED**

1. Fill the supply hopper with the seed to be treated, and position any other equipment in place.
2. Turn the switches to “ON” for the auger.
3. Turn the “CHEMICAL PUMP” switch to “AUTO”, and at the same time open the seed gate all the way open until the clip hits the stop. This will start the treating process.
4. When all seed has passed through the spray chamber, the pump will automatically shut off.

**Conversion Chart**

**1 ounce = 29.58 milliliters**

**1 gallon = 3.79 liters**

**1 kilogram = 2.2 pounds**

**1 unit = 50 lbs or 22.73 kg**

**1 bushel = approx. 60 lbs or 27.27 kg**

**1 cwt = 100 lbs or 45.45 kg**

SECTION  
F**TROUBLESHOOTING**

Below is a table describing the most frequent problems and solutions with the USC AT Series Seed Treater. For further assistance, contact your local USC dealer.

Problem	Possible Cause	Solution
Pump will not turn off in "AUTO" when seed runs out.	<ol style="list-style-type: none"> <li>1. Proximity switch is dirty.</li> <li>2. Proximity switch is set too sensitive.</li> </ol>	<ol style="list-style-type: none"> <li>1. Clean proximity switch.</li> <li>2. Adjust the pump proximity switch sensitivity by turning adjustment screw counter-clockwise (page 27).</li> </ol>
Pump will not turn on in "AUTO"	<ol style="list-style-type: none"> <li>1. Proximity switch is not staying covered.</li> <li>2. Proximity switch is not sensitive enough.</li> </ol>	<ol style="list-style-type: none"> <li>1. Make sure proximity switch is staying covered with seed.</li> <li>2. Adjust pump proximity switch sensitivity by turning the adjustment screw clockwise (page 27).</li> </ol>
Incorrect rate of treatment being applied	<ol style="list-style-type: none"> <li>1. Incorrect nozzle size.</li> <li>2. Nozzle or filter is plugged.</li> <li>3. Not enough liquid in tank while agitation pump is running.</li> </ol>	<ol style="list-style-type: none"> <li>1. Check the nozzle size.</li> <li>2. Check for any restrictions in the nozzle or the filter.</li> <li>3. Turn the agitation pump to "Off" (when running, it will cause the pump to suck air).</li> </ol>
Auger overload keeps tripping	<ol style="list-style-type: none"> <li>1. Seed flow is too high.</li> <li>2. Too much liquid being applied.</li> </ol>	<ol style="list-style-type: none"> <li>1. Slow down seed flow.</li> <li>2. Lower the liquid rate.</li> </ol>

## **PROXIMITY SWITCH ADJUSTMENT GUIDE**

The proximity switch located in the supply hopper of the seed treater detects when seed is present. This will automatically shut off the chemical pump when all seed has left the supply hopper.

Sometimes the proximity switch does not properly work. This can be caused from wear, dust, or even moisture. The first step is to clean the lens of the proximity switch. If this does not solve the problem, the next step would be to adjust the sensitivity of the proximity switch.

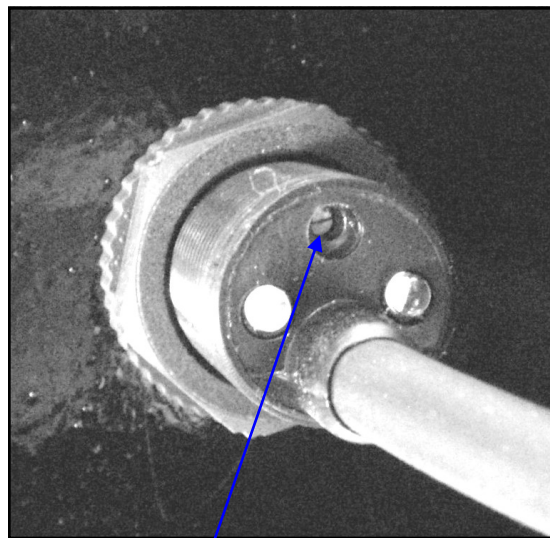

*Sensitivity Adjustment Screw*

Using the small screwdriver provided inside the control panel, you can adjust the proximity switch by turning the adjusting screw on the back of the proximity switch.

- Turn Clockwise to make the proximity switch more sensitive.
- Turn Counterclockwise to make the proximity switch less sensitive.



*Proximity Switch Screwdriver*

**SECTION  
G****MAINTENANCE**

Proper maintenance of the USC AT Series Seed Treater is critical for peak performance, reliability and accuracy of this system. The following is a guideline for the type of maintenance and servicing that should be performed on this unit. Your environment and uses may require additional maintenance and service beyond this list to assure a reliable and safe unit. The operator of this unit has ultimate responsibility to identify areas of concern and rectify them before they become a hazard or safety issue. There is no substitute for a trained, alert operator.



Do not put this unit into operation with any questionably maintained parts. Poor performance or a hazard may occur.

---

**AUGER**

- Remove shields and grease bearings.
- Inspect and tighten belts.
- Check motor.

---

**MIX TANK**

- Check centrifugal agitation pump.
- Check valves, fittings, and plug on bottom of tank.

---

**PUMPS AND PLUMBING**

- Check application pump.
- Inspect tubing and valves.
- Tighten hose clamps and check filter.

---

**CONTROL PANEL**

- Check and tighten wire connections.
- Check starters and overloads.
- Check timers and relays.
- Check the switches on the front of the panel.
- Inspect fuses and breakers.
- Check and set the proximity switches.

## SECTION H

# STORAGE

When storing the USC AT Series Seed Treater for long periods of time, the following procedure must be followed to reduce the chance of rust, corrosion and fatigue of the treater. You can also use these steps when storing the machine for the winter.



Protective rubber gloves and protective eye wear shall be used when cleaning the machine

### SUPPLY HOPPER

1. Clean out the supply hopper of any debris (compressed air can be used).
2. Wipe the proximity switch clean.
3. Tarp or cover the hopper to keep out any unwanted pests.

### SPRAY CHAMBER

1. Remove and clean the spray nozzle.
2. Reinstall the nozzle inside the spray chamber.

### AUGER

1. Grease upper and lower bearings on auger
2. Remove shield and check tension on belt.
3. Open the bottom clean out door to remove any debris (compressed air can be used).



**LIQUID SYSTEM**

1. Make certain the inside of the tank is completely drained of chemical residue and thoroughly flush the inside of the tank with clean water.
2. Remove and clean the filter.
3. Pump clean water through all areas of the plumbing including the mix tank, calibration tube, and valves.
4. Open all drain points, valves, and filter to let as much of the liquid drain as possible.
5. If the seed treater will be exposed to possible freezing temperatures, the final flush of the system should be made with a non-freezable liquid. Or use compressed air to blow the lines out from any moisture.

**SECTION  
I****MECHANICAL DRAWINGS**

The following pages show the parts of your AT Series Seed Treater. Please have the part number ready when ordering parts.

An electrical wiring diagram is located in the control panel of the AT Series Seed Treater at the time of shipment. The diagram located in the panel shows the exact electrical schematic for that model of seed treater. If you have any questions about the diagram, please call your local USC dealer.

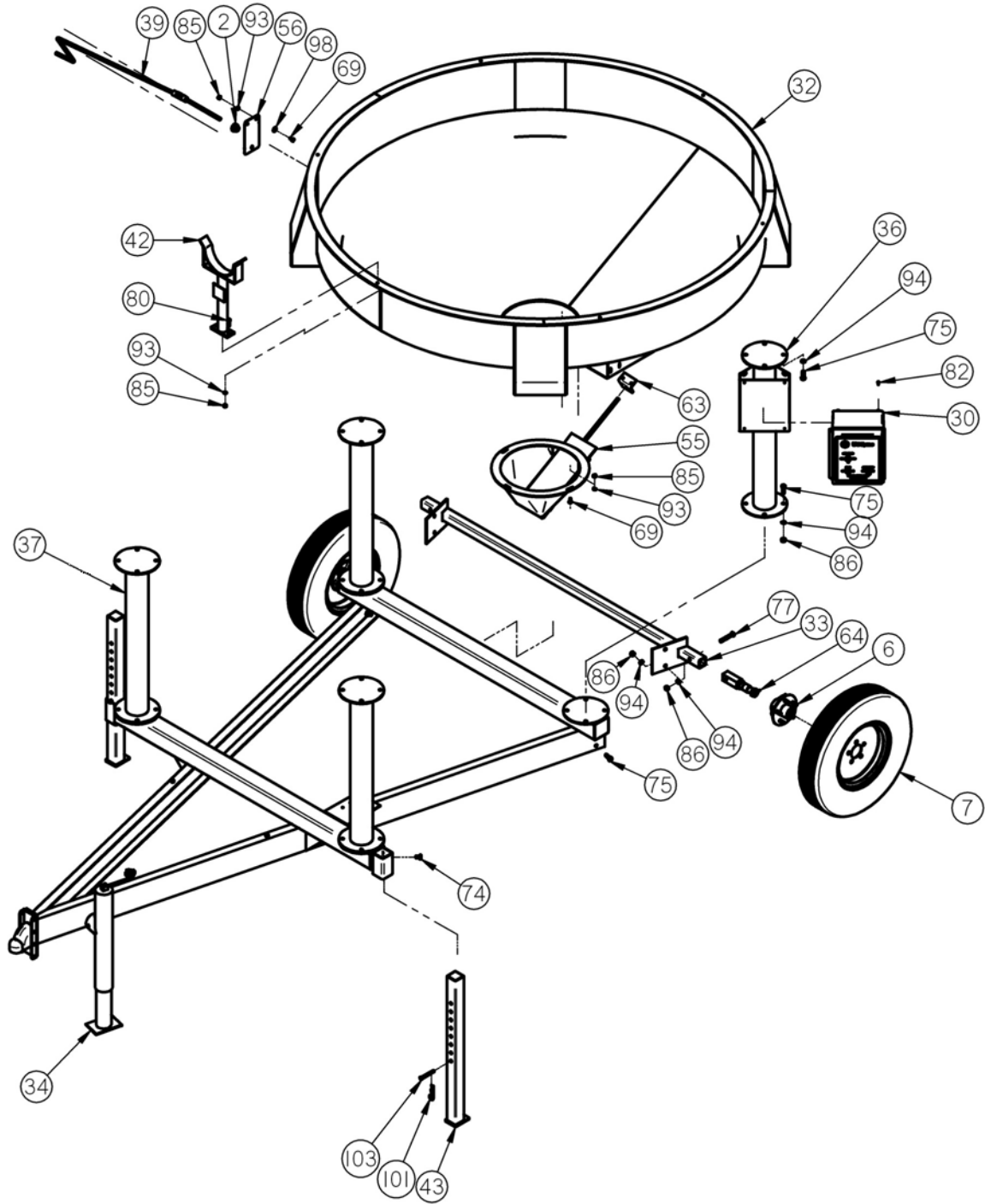



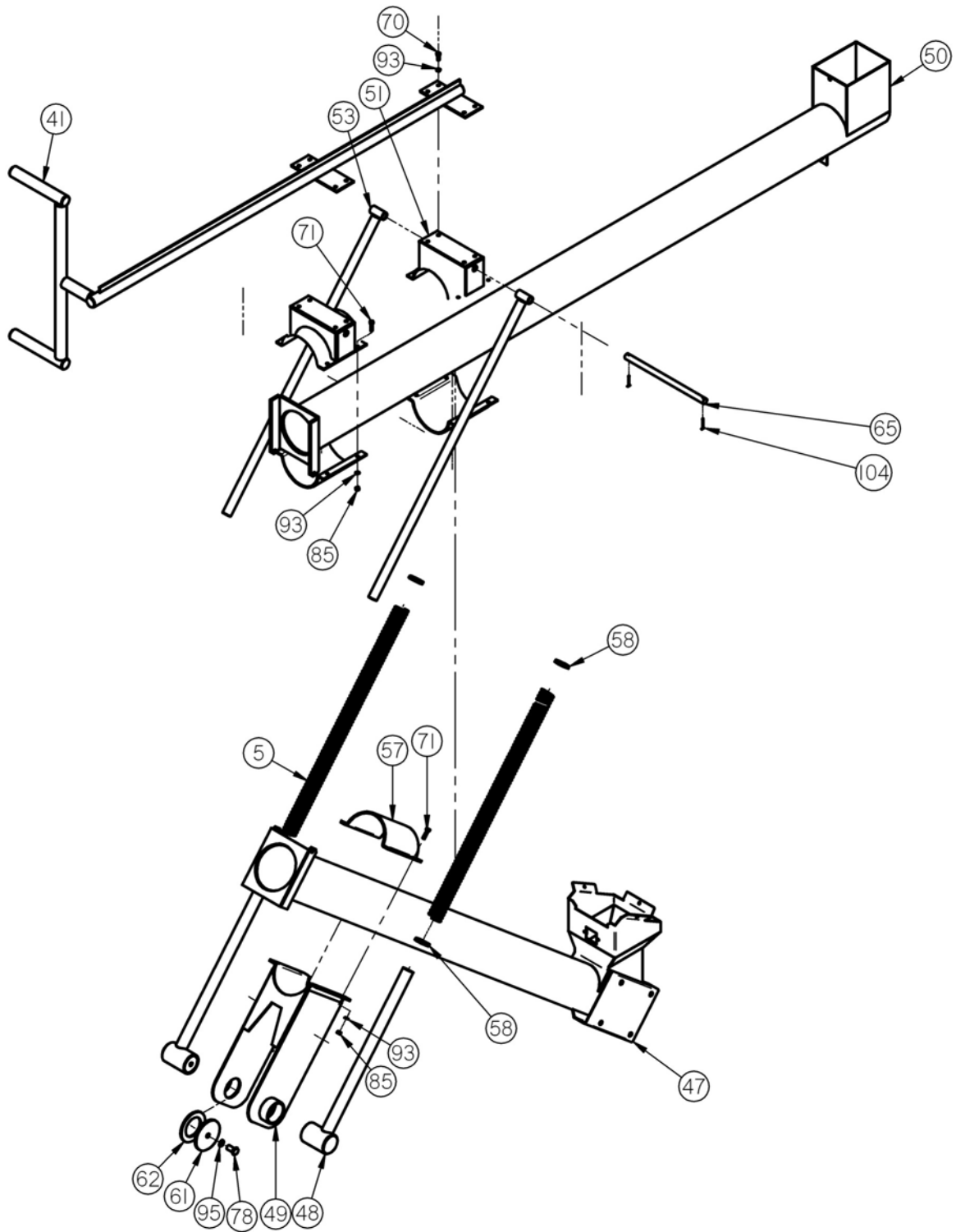

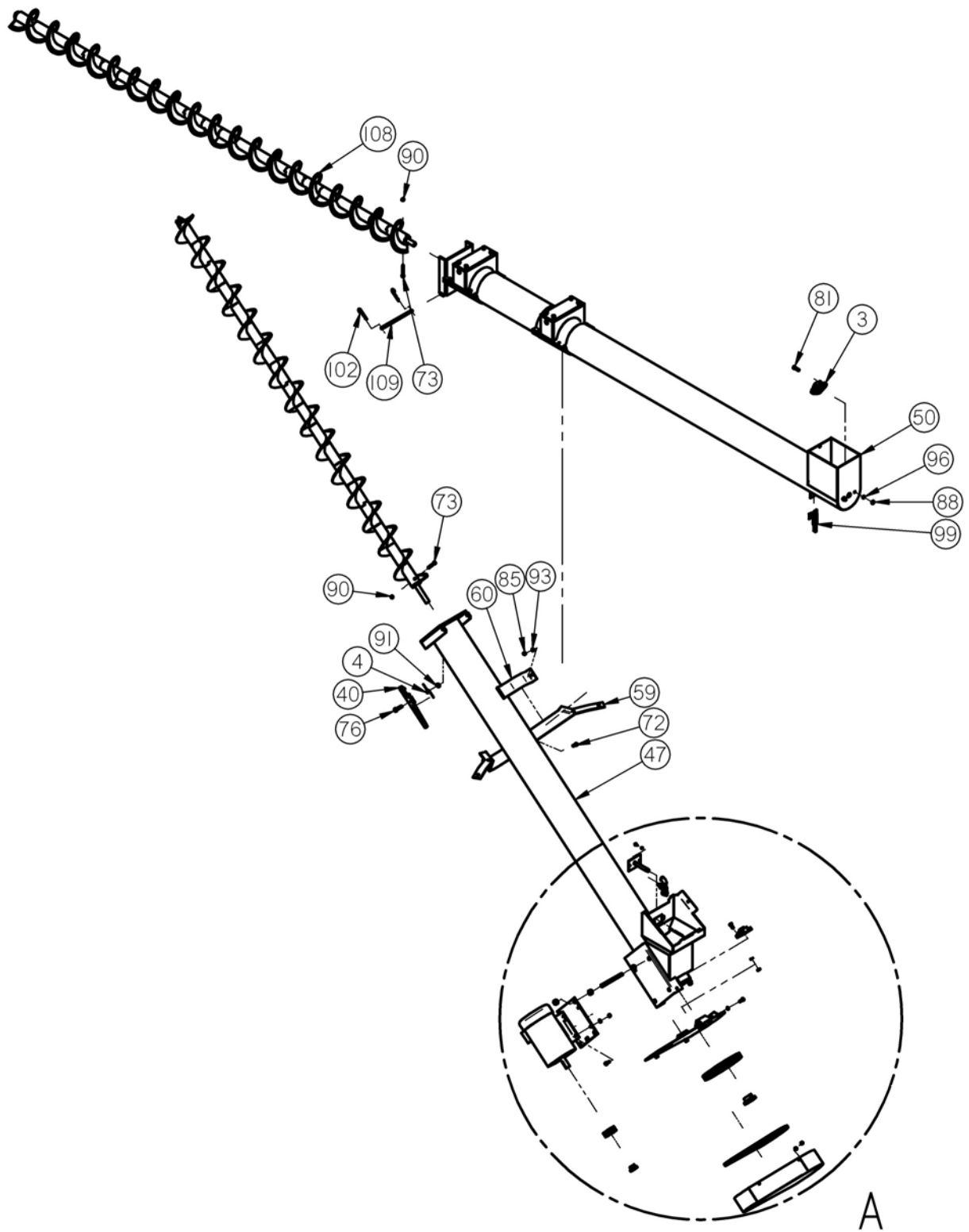

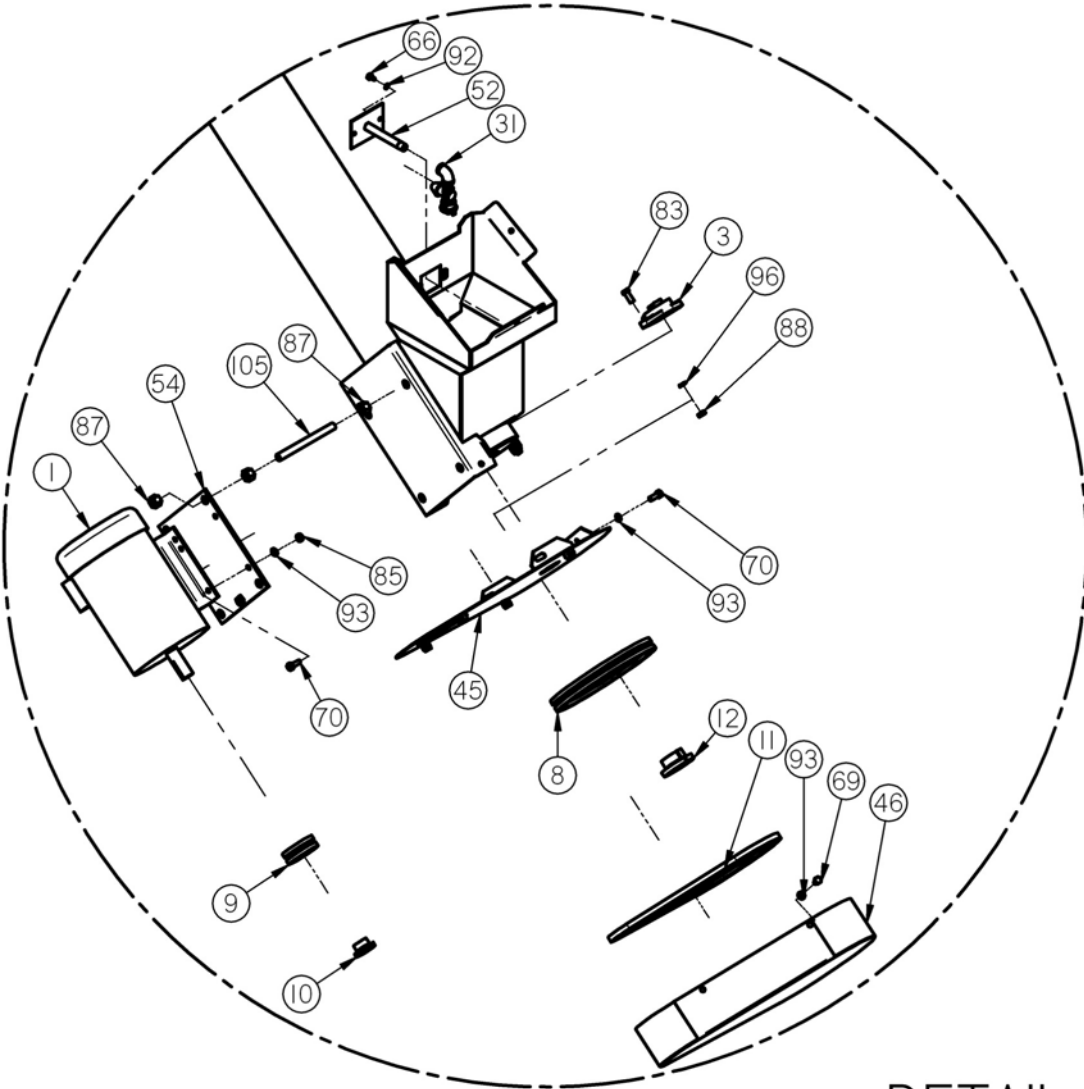

DETAIL A

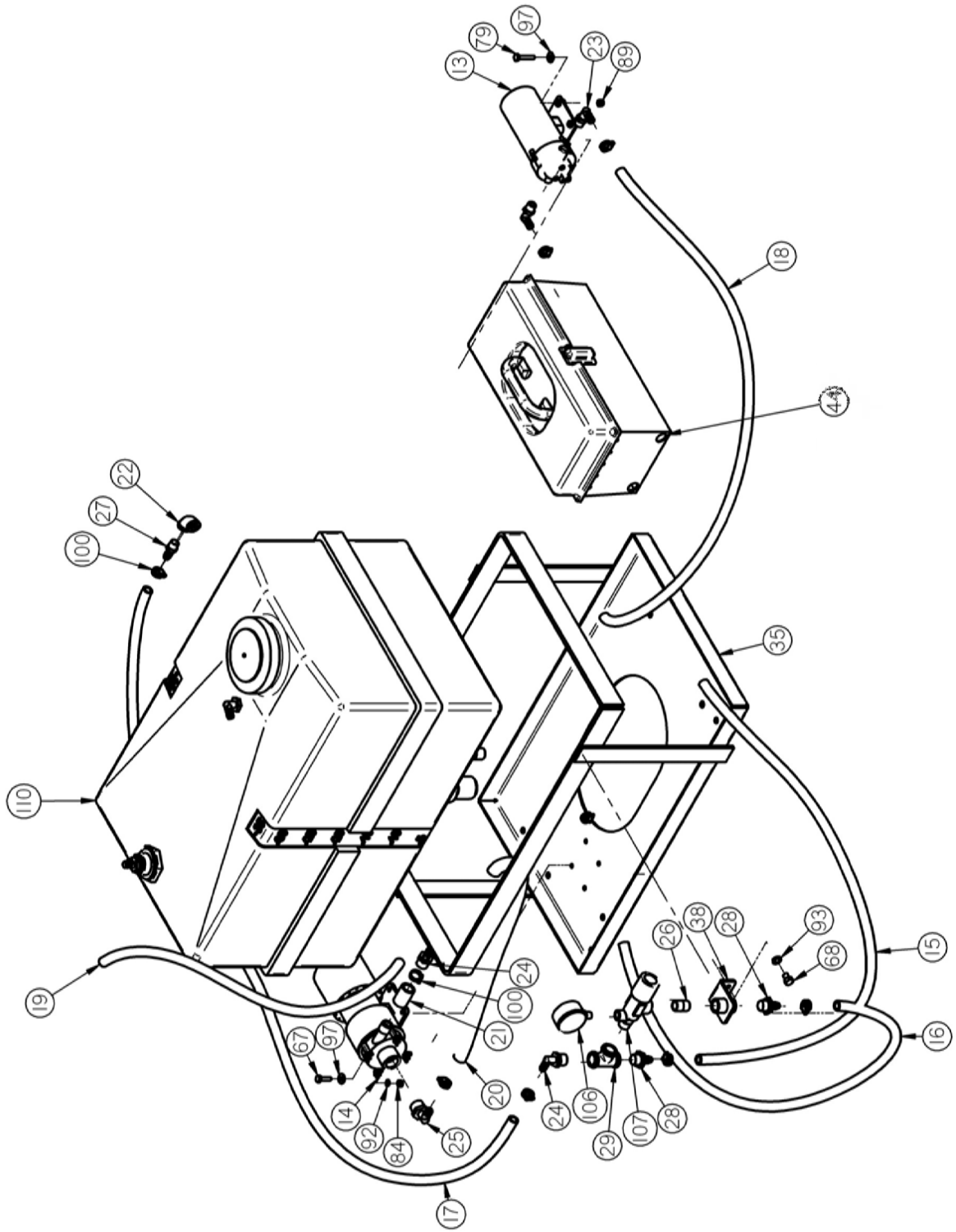

AT1000

Item Num-	Part Number	Part Description	Qty
1	01-01-0073	M3615T 5HP MOTOR	1
2	01-02-0027	SPROCKET, 9 TOOTH #40 CHAIN 1/2" BORE	1
3	01-03-0003	BEARING, 1" BORE, FLANGE MOUNT	2
4	01-04-0034	Torsion Spring .767 OD	1
5	01-04-0035	Compression Spring 300lb	2
6	01-06-0020	HUB	2
7	01-06-0021	WHL 14IN TIRE & RIM	2
8	01-08-0027	SHV 3V 10.6 SDS	1
9	01-08-0028	SHV 3V 3.15 JA	1
10	01-08-0029	Bushing JA 1.125	1
11	01-08-0030	BELT3VX475	1
12	01-08-0032	BUSHING SDS 1.00 KWY	1
13	02-01-0021	PUMP	1
14	02-01-0023	CENR 4GPM 1740RPM (RECERC) 115V	1
15	02-03-0005	100A35 .500IN TBG	1
16	02-03-0005	100A36 .500IN TBG	1
17	02-03-0005	100A39 .500IN TBG	1
18	02-03-0005	100A34 .500IN TBG	1
19	02-03-0005	100A37 .500IN TBG	1
20	02-03-0006	100A38 .750IN TBG	1
21	02-05-0031	FTTG CPLG .500 NPT FM BP	1
22	02-06-0008	FTTG 90 DEG .375NPT FM SS	1
23	02-06-0009	3/8-18 NPT, 1/2 BARB, 90 DEG. WP	2
24	02-06-0010	FTTG 90 DEG .500HB X .500NPT ML NYL	2
25	02-06-0011	FTTG 90 DEG .750HB X .500NPT ML NYL	1
26	02-07-0049	NIPPLE, 1/2-14 NPT X 1/2-14 NPT BR	1
27	02-08-0006	FTTG STGHT .500HB X .375NPT ML NYL	1
28	02-08-0007	FTTG STGHT .500HB X .500NPT ML NYL	2
29	02-09-0003	FTTG TEE .500 NPT FM SS	1
30	03-12-0052	PNL CNTL MNL ST ST800-2000 STD	1

AT1000

Item Num-	Part Number	Part Description	Qty
31	04-04-0026	SPRAY ARM	1
32	05-03-0081	WDMT,80-UNT HOPPER CONE	1
33	05-03-0233	ASSY, ADJ CHAMBER LP800 2005	1
34	05-03-0234	WDMT, LEG FRAME LP2000	1
35	05-03-0235	WDMT 35 GALL TNK FR AT	1
36	05-03-0236	WDMT LEGS 80 UNIT SHORT	1
37	05-03-0252	WDMT LEGS AT 1000	3
38	05-03-0296	WDMT PRES REGL MNT BRKT	1
39	05-04-0044	WDMT CRANK 80 UNIT SHORT	1
40	05-04-0046	WDMT AUGER CLMP AT1000	1
41	05-04-0047	AUGER HANDLE ASSY	1
42	05-04-0048	WDMT AUGER EXT HOLDER AT1000	1
43	05-05-0001	WDMT ADJ TREATER LEG	2
44	05-06-0020	BOX PUMP PROTECTION	1
45	05-06-0021	WDMT, BELT GUARD, AT1000	1
46	05-06-0022	WDMT, OUT BELT GUARD, AT1000	1
47	05-07-0047	WDMT HOPP-AUGER TUBE AT1000	1
48	05-07-0107	SPRING ROD GUIDE ASSY	2
49	05-08-0024	WDMT ADJUST SPRING BRKT	1
50	05-08-0025	WDMT, AUGER TOP EXTENSION	1
51	05-08-0026	WDMT AUGER SPRING BRKT AT1000	2
52	05-08-0027	WDMT NIPPLE/BRKT AT1000	1
53	05-08-0028	WDMT ADJUST SPRING GUILD ROD	2
54	05-08-0029	WDMT MOTOR MOUNT BRKT AT1000	1
55	05-08-0030	WDMT,END GATE W/ SLIDE DOOR	1
56	05-10-0414	MANUAL GATE ROD HOLDER 50UNIT	1
57	05-10-1277	BRKT SPRING/ARM CONECTOR AT1000	3
58	05-10-1308	WASHER SPRING SPACER 2.5IN OD 1.5IN ID X.375	4
59	05-10-1309	BRKT U-SUPPORT STRAP AT1000	1
60	05-10-1310	BRKT TOP U-SPPORT STRAP AT1000	1

AT1000

Item Num-	Part Number	Part Description	Qty
61	05-10-1363	Spring Guide Back Plate	2
62	05-10-1364	UHMW Washer	2
63	05-10-1380	ROD ADJUSTMENT BRKT	1
64	05-11-0093	SPINDLE W/17/32" HOLE	2
65	05-11-0096	SHAFT 1" OD X18.25 W/.125 HOLE	1
66	06-01-0004	BOLT .250-20 X .500 ZP GR5	2
67	06-01-0007	BOLT, .250-20 X 1 UNC ZP GRADE 5	2
68	06-01-0014	BOLT, .375-16 X 1/2 UNC ZP G5	2
69	06-01-0015	BOLT .375-16 X .750 ZP GR5	10
70	06-01-0016	BOLT .375-16 X 1.00 ZP GR5	21
71	06-01-0018	BOLT .375-16 X 1.50 ZP GR5	12
72	06-01-0019	BOLT .375-16 X 1.75 ZP GR5	2
73	06-01-0021	BOLT .375-16 X 3.00 ZP GR5	4
74	06-01-0024	BOLT .500-13 X .750 ZP GR5	2
75	06-01-0025	BOLT .500-13 X 1.50 ZP GR5	38
76	06-01-0027	BOLT .500-13 X 2.00 ZP GR5	1
77	06-01-0029	BOLT .500-13 X 3.25 ZP GR5	2
78	06-01-0034	BOLT, .750-10 X 1 1/2 UNC ZP GRADE 5	2
79	06-01-0052	BOLT, .250-20 X 1 1/2" UNC ZP G5	4
80	06-01-0053	BOLT .375-16 X 1.25 ZP GR5	2
81	06-01-0079	BOLT,.4375-14 G5 ZP 2.0	2
82	06-01-0090	SCRW MACH 10-32 X .750 ZP PHLP RND	4
83	06-01-0132	BOLT,.4375-14 G5 ZP 1.00	2
84	06-02-0001	NUT FULL .250-20 ZP GR5	2
85	06-02-0003	NUT FULL .375-16 ZP GR5	32
86	06-02-0004	NUT FULL .500-13 ZP GR5	24
87	06-02-0005	NUT, .625-11 UNC ZP GRADE 5	16
88	06-02-0039	NUT, .4375-14 ZP G5	4
89	06-03-0001	NUT,LOCK, .250-20 ZP G5 NYLON INSERT	4
90	06-03-0003	NUT NYL LOCK .375-16 ZP GR5	4

AT1000

Item Num-	Part Number	Part Description	Qty
91	06-03-0004	NUT,LOCK, .500-13 ZP SS NYLON INSERT	1
92	06-04-0001	WSHR LOCK SPLT .250 ZP	4
93	06-04-0003	WSHR LOCK SPLT .375 ZP	49
94	06-04-0004	WSHR LOCK SPLT .500 ZP	40
95	06-04-0006	WASHER, .750 LOCK ZP	2
96	06-04-0011	WASHER, .4375 LOCK ZP	4
97	06-05-0001	WASHER, FLAT .250	6
98	06-05-0004	WSHR FLAT .375 ZP	2
99	06-07-0002	LATCH, DE-STA-CO #53510	1
100	06-07-0006	CLMP HOSE .500 TO .906 X .313W ZP	12
101	06-09-0002	PIN CLIP HITCH 3.063 SIZE 9 ZP	3
102	06-09-0002	.125 Hitch Pin Clip	2
103	06-09-0005	PIN CLVS .500 X 3.50 PLN	2
104	06-09-0023	.125 X 2.00 ZP COTTER PIN	2
105	06-14-0007	THREADED ROD .625-11 ZP	4
106	07-03-0002	GAUGE, 100 PSI	1
107	07-03-0012	150 PSI RELIEF VALVE	1
108	11-05-0006	Auger Shaft AT1000	1
109	11-07-0026	AUGER PIVOT .500IN RND BAR	1
110	13-05-0048	ASSY MIX TNK 35 GALL RECT AT/ST	1



## SECTION **LIMITED WARRANTY**

USC, LLC, (Manufacturer) warrants its seed treating equipment as follows:

1. **Limited Warranty:** Manufacturer warrants that the Products sold hereunder will be free from defects in material and workmanship for a period of 12 months from date of shipment. If the Products do not conform to this Limited Warranty during the warranty period, Buyer shall notify Manufacturer in writing of the claimed defects and demonstrate to Manufacturer satisfaction that said defects are covered by this Limited Warranty. If the defects are properly reported to Manufacturer within the warranty period, and the defects are of such type and nature as to be covered by this warranty, Manufacturer shall, at its expense, furnish replacement Products or, at Manufacturer's option, replacement parts for the defective products. Shipping and installation of the replacement Products or replacement parts shall be at the Buyer's expense.

2. **Other Limits:** THE FOREGOING IS IN LIEU OF ALL OTHER WARRANTIES, EXPRESSED OR IMPLIED, INCLUDING BUT NOT LIMITED TO THE IMPLIED WARRANTIES OF MERCHANTABILITY AND FITNESS FOR A PARTICULAR PURPOSE. Manufacturer does not warrant against damages or defects arising from improper installation (where installation is by persons other than Manufacturer), against defects in products or components not manufactured by Manufacturer, or against damages resulting from such non-Manufacturer made products or components. Manufacturer passes on to the Buyer the warranty it received (if any) from the maker of such non-Manufacturer made products or components. This warranty also does not apply to Products upon which repairs and/or modifications have been effected or attempted by persons other than pursuant to written authorization by Manufacturer. Manufacturer does not warrant against casualties or damages resulting from misuse and/or abuse of product(s), acts of nature, effects of weather, including effects of weather due to outside storage, accidents, or damages incurred during transportation by common carrier.

3. **Exclusive Obligation:** THIS WARRANTY IS EXCLUSIVE. The sole and exclusive obligation of Manufacturer shall be to repair or replace the defective Products in the manner and for the period provided above. Manufacturer shall not have any other obligation with respect to the Products or any part thereof, whether based on contract, tort, strict liability or otherwise. Under no circumstances, whether based on this Limited Warranty or otherwise, shall Manufacturer be liable for incidental, special, or consequential damages.

4. **Other Statements:** Manufacturer's employees or representatives' oral or other written statements do not constitute warranties, shall not be relied upon by Buyer, and are not a part of the contract for sale or this limited warranty.

5. **Return Policy:** Approval is required prior to returning goods to USC, LLC. A restocking fee will apply.

6. **Entire Obligation:** This Limited Warranty states the entire obligation of Manufacturer with respect to the Products. If any part of this Limited Warranty is determined to be void or illegal, the remainder shall remain in full force and effect.



**USC, LLC**

2320 124th road

Sabetha, Ks 66534

PHONE: (785) 431-7900

FAX: (785) 431-7950

EMAIL: [sales-team@uscllc.com](mailto:sales-team@uscllc.com)

WEB: [www.uscllc.com](http://www.uscllc.com)