

AT500H MANUAL TREATER

Operators Manual



Document: TD - 09 - 06 - 1034

Revision: A



INTRODUCTION

Thank you for choosing USC, LLC for your equipment needs. We appreciate your business and will work diligently to ensure that you are satisfied with your choice.

OVERVIEW

The purpose of this manual is to provide you with the basic information needed to operate and maintain the AT500H Treater . It does not hold USC, LLC liable for any accidents or injuries that may occur.

OPERATOR RESPONSIBILITIES

As the purchaser/owner/operator of this equipment and control system, you have an obligation to install, operate, and maintain the equipment in a manner that minimizes the exposure of people in your care to any potential hazards inherent in using this equipment. It is critical that the owner of this equipment:

- Has a clear and documented understanding of the process this machine is being used in and of any resulting hazards or special requirements arising from this specific application.
- Allow only properly trained and instructed personnel to install, operate or service this equipment.
- Maintain a comprehensive safety program involving all who work with this machine and other associated process equipment.
- Establish clear areas of staff responsibility (e.g. operation, setup, sanitation, maintenance, and repairs).
- Provide all personnel with necessary safety equipment.
- Periodically inspect the equipment to insure that the doors, covers, guards, and safety devices are in place and functioning, that all safety instructions and warning labels are intact and legible, and that the equipment is in good working order.
- In addition to the operating instructions, observe and enforce the applicable legal and other binding regulations, national and local codes.

As the person with the most to gain or lose from working safely, it is important that you work responsibly and stay alert. By following a few simple rules, you can prevent an accident that could injure or kill you or a co-worker.

AT500H TREATER

- Do not operate, clean, or service this equipment until you have read and understood the contents of this manual. If you do not understand the information in this manual, bring it to the attention of your supervisor, or call USC at (785) 431-7900 for assistance.
- Any operator who is known or suspected to be under the influence of alcohol or drugs should not be allowed to operate the equipment.
- Understand and follow the safety practices required by your employer and this manual.
- **PAY ATTENTION** to what you and other personnel are doing and how these activities may affect your safety.
- **Failure to follow these instructions may result in serious personal injury or death.**

RECEIVING YOUR EQUIPMENT

As soon as the equipment is received, it should be carefully inspected to make certain that it has sustained no damage during shipment and that all items listed on the packing list are accounted for. If there is any damage or shortages, the purchaser must immediately notify USC, LLC. Ownership passes to purchaser when the unit leaves the USC, LLC. premises. The purchaser is responsible for unloading and mounting all components of the equipment.

Document the serial number of the machine for future reference. The serial number is located on the frame above the treater control panel.



SERIAL NUMBER: _____

TABLE OF CONTENTS

<u>Section</u>	<u>Contents</u>	<u>Page #</u>
Section A	Safety Instructions.....	5
Section B	Installation	14
Section C	Mechanical Operation.....	17
	AT500H Treater Overview.....	17
	Seed Wheel Overview	18
Section D	Electrical Operation	20
Section E	Calibration	22
	Seed Flow Calibration	22
	Adjusting Seed Flow Gate	23
	Treating seed	24
Section F	Troubleshooting.....	25
	Proximity Sensor Adjustment Guide	26
Section G	Maintenance	27
Section H	Belt Tensioning Specification.....	30
Section I	Storage.....	31
Section J	Mechanical Drawings	34
Section K	Limited Warranty.....	63

SAFETY INSTRUCTIONS

SECTION A

Every year accidents in the work place maim, kill and injure people. Although it may be impossible to prevent all accidents, with the right combination of training, operating practices, safety devices and operator vigilance, the number of accidents can be significantly reduced. The purpose of this section is to educate equipment users about hazards, unsafe practices and recommended hazard avoidance techniques.

SAFETY WORDS AND SYMBOLS

It is very important that operators and maintenance personnel understand the words and symbols that are used to communicate safety information. Safety words, their meaning and format, have been standardized for U.S. manufacturers and published by the American National Standards Institute (ANSI). The European Community (E.C.) has adopted a different format based on the International Standards Organization (I.S.O.) and applicable machinery directives. Both formats are presented below. Graphic symbols are not standardized but most manufacturers will use some variation of the ones seen in this manual.



Indicates an imminently hazardous situation which, if not avoided, **will** result in death or serious injury.



Indicates a potentially hazardous situation which, if not avoided, **could** result in death or serious injury.



Indicates a potentially hazardous situation which, if not avoided, **may** result in minor or moderate injury and/or property damage.



Provides additional information that the operator needs to be aware of to avoid a potentially hazardous situation.



Mandatory Lockout Power Symbol. Disconnect, lockout and tagout electrical and other energy sources before inspecting, cleaning or performing maintenance on this panel.



International Safety Alert Symbol. The exclamation point (!) surrounded by a yellow triangle indicates that an injury hazard exists. However, it does not indicate the seriousness of potential injury. The exclamation point (!) is also used with the DANGER, WARNING and CAUTION symbols so the potential injury is indicated.



Electrocution Hazard Symbol. This symbol indicates that an electrocution hazard exists. Serious injury or death could result from contacting high voltage.



International Electrocution Hazard. This symbol indicates that an electrocution hazard exists. Serious injury or death could result from contacting high voltage.



Mandatory Read Manual Action Symbol. (I.S.O. format) This symbol instructs personnel to read the Operators Manual before servicing or operating the equipment.



Mandatory Read Manual Action Symbol. This symbol instructs personnel to read the Operators Manual before servicing or operating the equipment.

NOTICE

Notice is used to notify people of important installation, operation or maintenance information which is not hazard related.

LOCKOUT / TAGOUT PROCEDURES

Lockout/Tagout is the placement of a lock/tag on an energy isolating device in accordance with an established procedure. When taking equipment out of service to perform maintenance or repair work, always follow the lockout/tagout procedures as outlined in ANSI Z344.1 and/or OSHA Standard 1910.147. This standard “requires employers to establish a program and utilize procedures for affixing appropriate lockout devices or tagout devices to energy isolating devices and to otherwise disable machines or equipment to prevent unexpected energizing, start-up, or release of stored energy in order to prevent injury to employees.”

HAZARD REVIEW



Electrocution Hazard

Electrocution accidents are most likely to occur during maintenance of the electrical system or when working on or near exposed high voltage wiring. This hazard does not exist when the electrical power has been disconnected, properly locked, and tagged out.



Automatic Start Hazard

This equipment may be controlled by an automated system and may start without warning. Failure to properly disconnect, lockout, and tagout all energy sources of remotely controlled equipment creates a very hazardous situation and could cause injury or even death. PLEASE STAY CLEAR AND BE ALERT.

YOU are responsible for the **SAFE** operation and maintenance of your USC, LLC equipment . **YOU** must ensure that you and anyone else who is going to operate, maintain or work around the equipment be familiar with the operating and maintenance procedures and related **SAFETY** information contained in this manual. This manual will take you step-by-step through your working day and alert you to good safety practices that should be adhered to while operating the equipment

Remember, **YOU** are the key to safety. Good safety practices not only protect you, but also the people around you. Make these practices a working part of your safety program. Be certain that **EVERYONE** operating this equipment is familiar with the recommended operating and maintenance procedures and follows all the safety precautions. Most accidents can be prevented. Do not risk injury or death by ignoring good safety practices.

- Equipment owners must give operating instructions to operators or employees before allowing them to operate the machine, and at least annually thereafter per OSHA (Occupational Safety and Health Administration) regulation 1928.57.
- The most important safety device on this equipment is a **SAFE** operator. It is the operator's responsibility to read and understand **ALL** Safety and Operating instructions in the manual and to follow them. All accidents can be avoided.
- A person who has not read and understood all operating and safety instructions is not qualified to operate the machine. An untrained operator exposes himself and bystanders to possible serious injury or death.
- Do not modify the equipment in any way. Unauthorized modification may impair the function and/or safety and could affect the life of the equipment.
- Think SAFETY! Work SAFELY!

GENERAL SAFETY

1. Read and understand the operator's manual and all safety labels before operating, maintaining, adjusting or unplugging the equipment .
2. Only trained persons shall operate the equipment . An untrained operator is not qualified to operate the machine.
3. Have a first-aid kit available for use should the need arise, and know how to use it.



AT500H TREATER

4. Provide a fire extinguisher for use in case of an accident. Store in a highly visible place.
5. Do not allow children, spectators or bystanders within hazard area of machine.
6. Wear appropriate protective gear. This includes but is not limited to:
 - A hard hat
 - Protective shoes with slip resistant soles
 - Protective goggles
 - Heavy gloves
 - Hearing protection
 - Respirator or filter mask
7. Place all controls in neutral or off, stop motor, and wait for all moving parts to stop. Then disable power source before servicing, adjusting, repairing, or unplugging.
8. Review safety related items annually with all personnel who will be operating or maintaining the equipment.



OPERATING SAFETY:

1. Read and understand the operator's manual and all safety labels before using.
2. Disconnect and disable electrical supply completely and wait for all moving parts to stop before servicing, adjusting, repairing or unplugging.
3. Clear the area of bystanders, especially children, before starting.
4. Be familiar with the machine hazard area. If anyone enters hazard area, shut down machine immediately. Clear the area before restarting.
5. Keep hands, feet, hair and clothing away from all moving and/or rotating parts.
6. Stay away from overhead obstructions and power lines during operation and transporting. Electrocutation can occur without direct contact.
7. Do not operate machine when any guards are removed.
8. Inspect welds and repair if needed.

PLACEMENT SAFETY

1. Move only with the appropriate equipment
2. Stay away from overhead power lines when moving equipment. Electrocutation can occur without direct contact.
3. Be familiar with machine hazard area. If anyone enters hazard areas, shut down machine immediately. Clear the area before restarting.
4. Operate the equipment on level ground free of debris. Anchor the equipment to prevent tipping or upending.



Before placement of the equipment , be sure that ground is reasonably level. The equipment may topple or work improperly if the ground is too uneven, damaging the equipment and/or causing personal injury.

MAINTENANCE SAFETY

1. Review the operator's manual and all safety items before working with, maintaining or operating the equipment .
2. Place all controls in neutral or off, stop motors, disable power source, and wait for all moving parts to stop before servicing, adjusting, repairing or unplugging.
3. Follow good shop practices:
Keep service area clean and dry.
Be sure electrical outlets and tools are properly grounded.
Use adequate light for the job at hand.
4. Keep hands, feet, hair and clothing away from all moving and/or rotating parts.
5. Clear the area of bystanders, especially children, when carrying out any maintenance and repairs or making any adjustments.
6. Before resuming work, install and secure all guards when maintenance work is completed.
7. Keep safety labels clean. Replace any sign that is damaged or not clearly visible.



SAFETY LABELS

1. Keep safety labels clean and legible at all times.
2. Replace safety labels that are missing or have become illegible.
3. Replaced parts that displayed a safety sign should also display the current sign.
4. Replacement safety labels are available. Contact USC at (785) 431-7900 .

How to Install Safety Labels:

- Be sure that the installation area is clean and dry.
- Be sure temperature is above 50°F (10°C).
- Decide on the exact position before you remove the backing paper.
- Remove the smallest portion of the split backing paper.
- Align the sign over the specified area and carefully press the small portion with the exposed sticky backing in place.
- Slowly peel back the remaining paper and carefully smooth the remaining portion of the sign in place.
- Small air pockets can be pierced with a pin and smoothed out using the piece of sign backing paper.



Located on the USC equipment you will find safety labels. Always be sure to read and follow all directions on the labels.



Guards provided with USC equipment are to remain in place during operation.

Think **SAFETY!** Work **SAFELY!**

REMEMBER—If Safety Signs have been damaged, removed, become illegible, or parts replaced without safety signs, new signs must be applied. New safety signs are available from USC at (785) 431-7900.



Part # 09-02-0001



Part # 09-02-0002

AT500H TREATER



Part # 09-02-0001

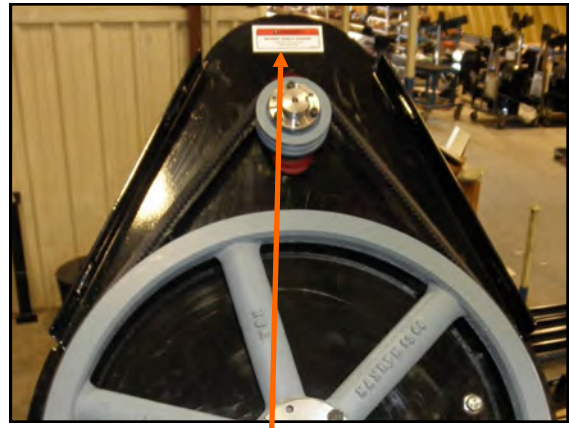

Part # 09-02-0010



Part # 09-02-0012

**SECTION
B**

INSTALLATION



HIGH VOLTAGE ~ Always disconnect the power source before working on or near the control panel or lead wires.



HIGH VOLTAGE ~ Use insulated tools when making adjustments while the controls are under power.



Permanent installation may require additional electrical cords, chemical tubing, and air lines, since each installation is unique.

SET-UP

The following steps outline the initial set-up of your USC AT500H Treater :

1. Clear the area of bystanders, especially small children, before moving.
2. Be sure there is enough clearance from overhead obstructions and power lines or other equipment to move the machine into its working position.
3. Using a forklift, place the AT500H Treater in the desired position on a level surface.



USC highly recommends that the AT500H Treater be set up inside a building or any covered structure to protect the machine from weathering.

4. Inspect AT500H Treater thoroughly for screws, bolts, fittings, etc. which may have come loose during shipping.
5. Check and tighten hose connections.

AT500H TREATER

6. Have a certified electrician provide power to the seed treating system. Provide convenient shutdown switches, comply with local electrical codes and ensure that the system is properly grounded and bonded. All USC control panels must be connected adhering to the same electrical requirements as specified in the main control panel on the power requirement tag (right), or the electrical schematic shipped with the piece of equipment. This will power the USC AT500H seed treater and any attached conveyors.

Mfg. By: USC, LLC Max voltage: 230V, 1PH, 60 HZ Total FLA: 57 Largest Motor FLA: 19 Schematic number: 03-12-0378A Enclosure rating: UL type 1 Short Circuit Current Rating: 5ka RMS Sym, 600V Max
WARNING To maintain over current, short-circuit and ground fault protection, the manufacturer's instruction for selection of overload and short circuit protection must be followed to reduce the risk of fire or electrical shock.
WARNING If an overload or a fault current interruption occurs, circuits must be checked to determine the cause of the interruption. If a fault condition exists, the current-carrying components should be examined and replaced if damaged, and the integral current sensors must be replaced to reduce the risk of fire or electrical shock.
!! WARNING !! 230Volts/ Single Phase/60 Hertz supply only L1 or L2 to Neutral voltage must not exceed 120 Volts!!

Incoming power connected to these terminals in the Treater Control Panel

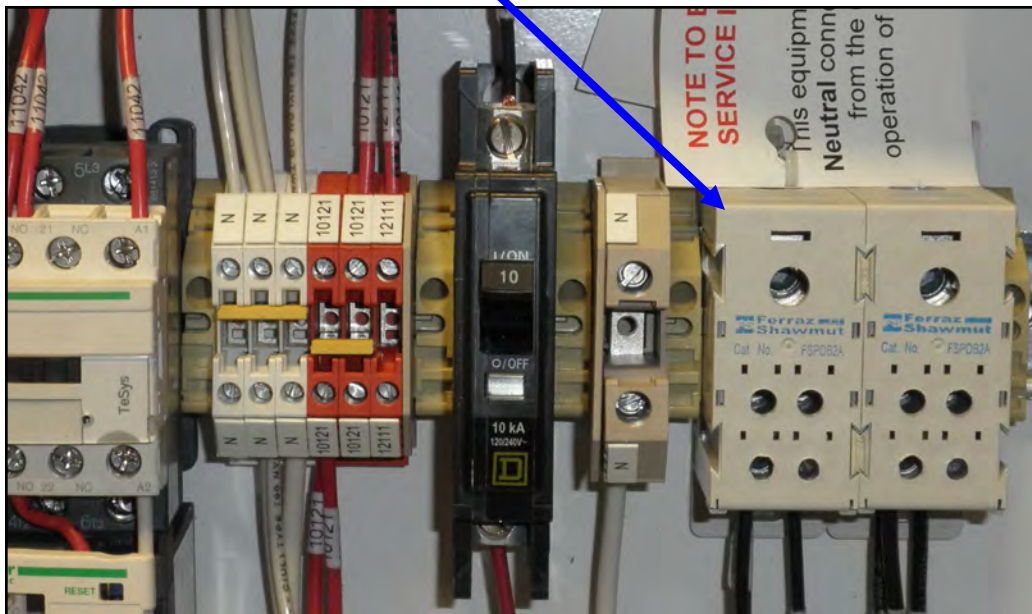

AT500H TREATER

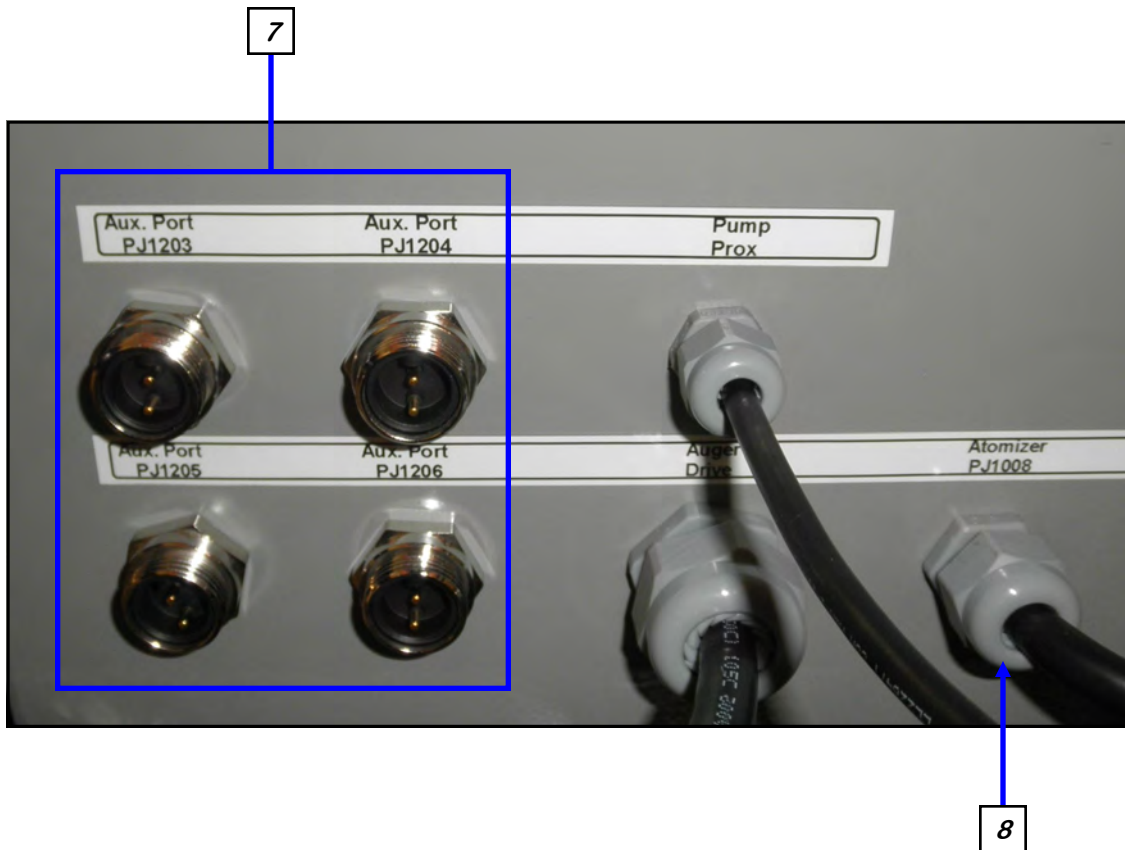

7. Connect the communication cable from the pump stand(s) to any of the four two wire connectors on the bottom of the control panel (PJ1203—PJ1204).
8. Connect the PJ1008 cable to the Atomizer motor.
9. Reverse the above procedure when removing the machine from its working position.

MECHANICAL OPERATION

SECTION C

AT500H TREATER OVERVIEW

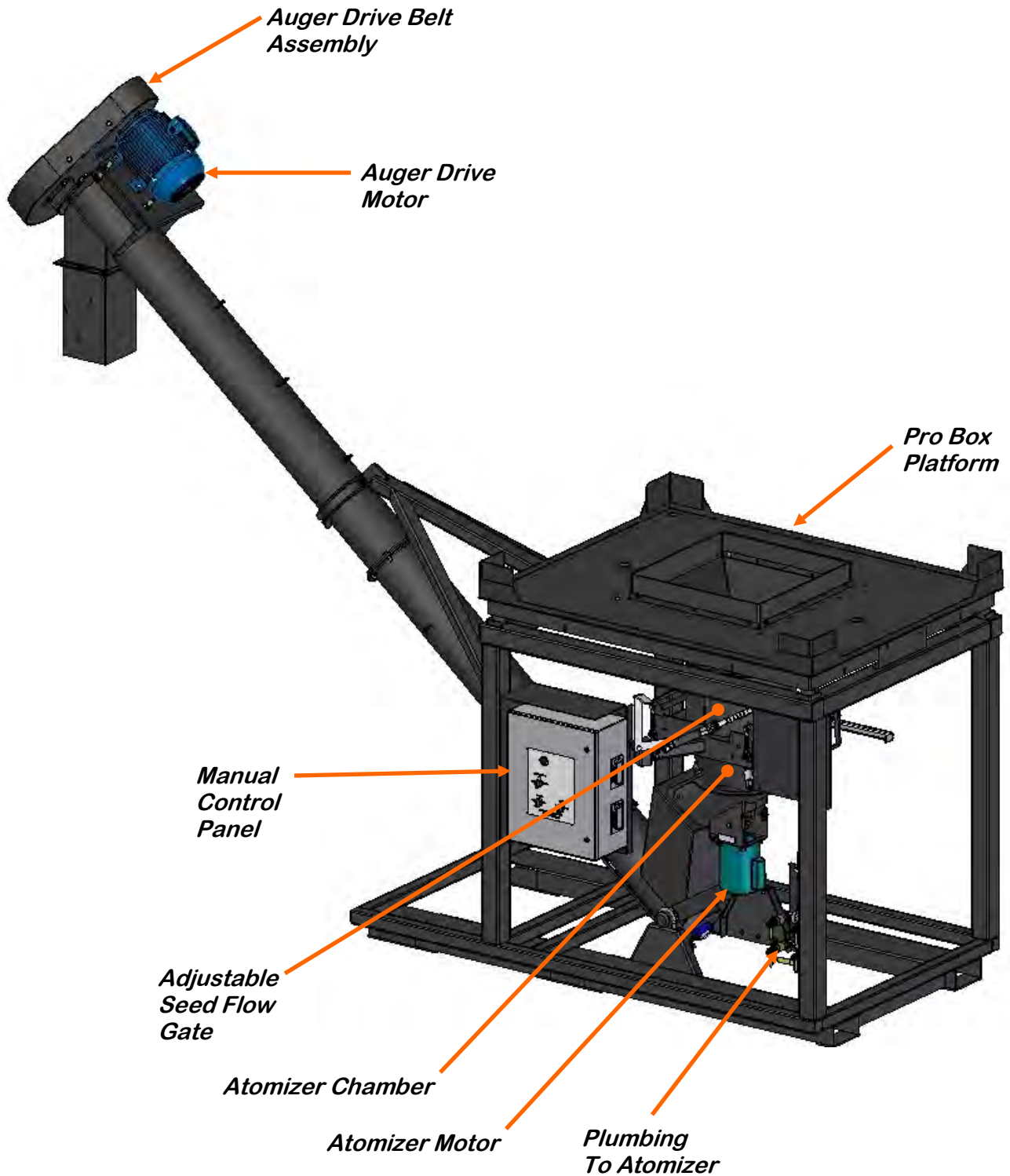

SEED WHEEL OVERVIEW

The Seed Wheel is designed to simplify and increase seed flow calibration accuracy. A rotating wheel is driven by a variable speed motor, which is set prior to treating the seed. This is mounted above the atomizer. The wheel consists of 8 identical pockets approximately 4 inches deep. As it rotates, the wheel captures a certain amount of seed in each pocket. After the seed is caught, the wheel continues rotation and dispenses the seed into the atomizer chamber. With the constant turn of the wheel, there is a consistent amount of seed always sent through the atomizer.

A cup is used to represent a certain percentage of one of the wheels pockets. To calibrate the seed flow, take a sample of the seed to be treated using the cup and weigh it. From the weight of the seed sample and by also knowing the RPM of the wheel, you can determine how fast that seed type will pass through the seed treater.

The purpose of the seed wheel is to simplify calibration and make seed flow calibration more accurate. The seed wheel saves time when switching to different seed sizes and seed types.

For more information on the operation of the Seed Wheel, see document number TD-09-06-1007 Seed Wheel operators manual.

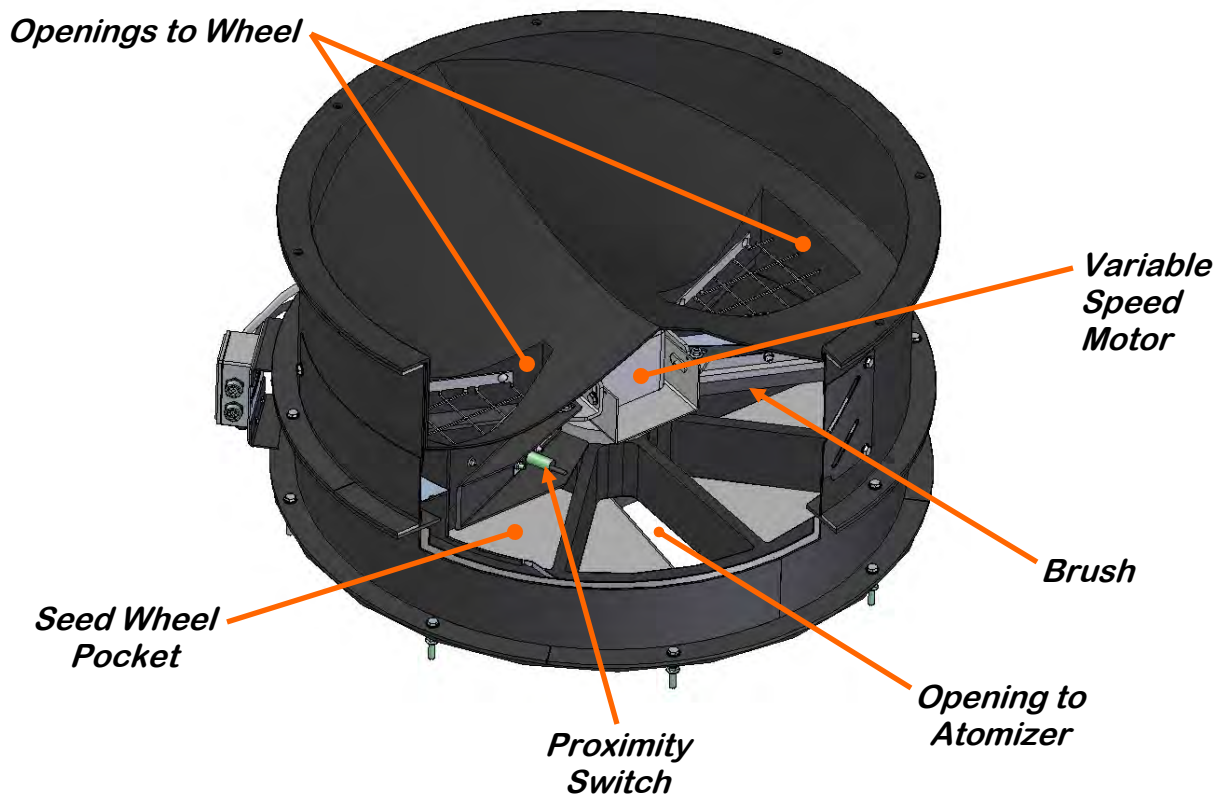

ATOMIZER CHAMBER

The atomizer chamber consists of a patented design which disperses treatment evenly to each seed. A motor drives the atomizer head at approximately 1725 RPM's. As treatment is being pumped into the atomizer chamber, it drops into the atomizer head. The centrifugal force of the spinning head forces the treatment to be sprayed out through a screen covering in all 360 degrees. Meanwhile, seed flows down out of the seed wheel and down on top of the distribution cone which disperses the seed down around the atomizer head. The atomizer can be easily accessed for cleaning and maintenance by pulling down on the quick release handle and sliding the atomizer away from the treater body (see page 28).

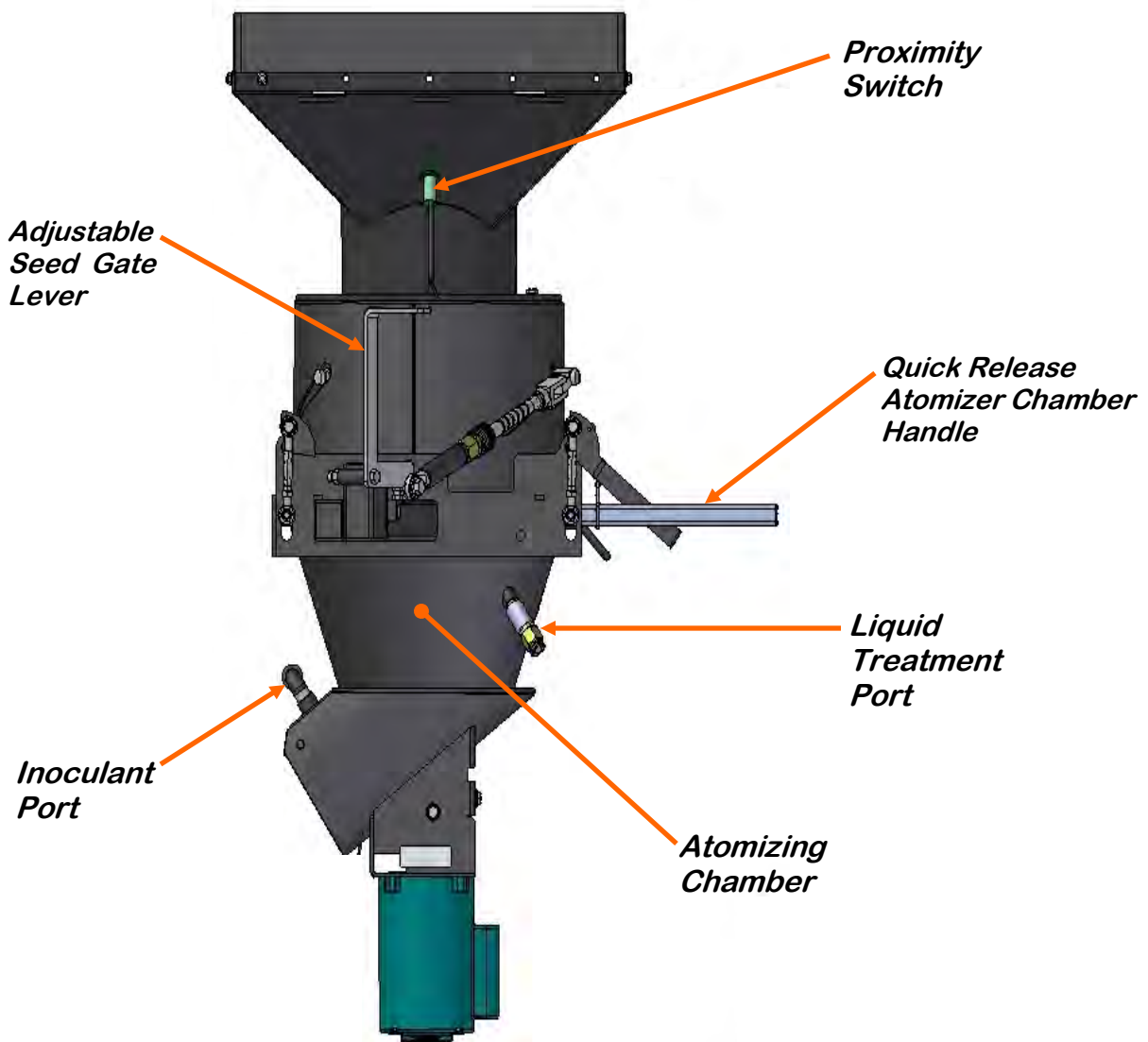

**SECTION
D**

ELECTRICAL OPERATION



HIGH VOLTAGE ~ Always disconnect the power source before working on or near the control panel or lead wires.



HIGH VOLTAGE ~ Use insulated tools when making adjustments while the controls are under power.



AUTHORIZED PERSONNEL only shall work on the control panel. Never allow anyone who has not read and familiarized themselves with the owner's manual to open or work on the control panels.

This section provides a general overview and description of the operator controls for the AT500H Treater.

NOTICE

USC recommends the use of surge protection device with a minimum rating of 700VA for all Control Panels.

General Panel Descriptions

The AT500H Control Panel is a plug connected enclosure that is located on the side of the treater frame. This panel connects the AT500H electrical components to up to four external components, a pump stand for example. Each external piece of equipment is controlled by the AUXILIARY PORTS switch. Another cable connects to the atomizer motor and is controlled by the ATOMIZER on / off switch. Power is supplied by a standard 110V plug. Refer to the control panel and the electrical schematic for proper voltage and amperage of the machine. There is also 4 , 3 amp plugs mounted on the right side of the enclosure. They are to provide power for the scale head, printer or a laptop computer if needed.

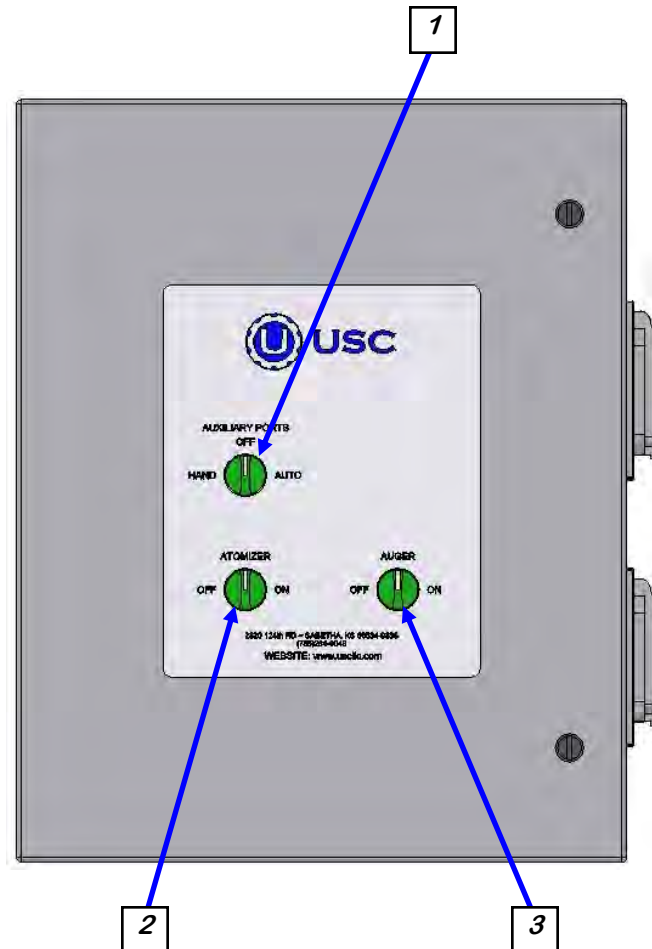

1. AUXILIARY PORTS SWITCH: When the auxiliary switch is turned to HAND, the pump(s) will immediately begin running. When the switch is turned to AUTO, the pump(s) will activate only when the proximity switch located at the bottom of the supply hopper detects seed. When the proximity switch does not detect seed, a timer relay located inside the control panel will automatically shut off the pump(s) a pre-determined amount of time after the hopper has emptied. The timer relay (right) located in the control panel is set to Mode D and has an adjustable knob with settings from 0 - 3. Each number represents the number of seconds from the time the hopper empties until the pumps will shut off. The time delay allows all seed in the hopper to have an equal coverage.



2. ATOMIZER SWITCH: This switch allows you the operator to turn the Atomizer on or off.

3. AUGAR SWITCH: This switch allows the operator to turn the auger on or off.

Bottom of Control Panel

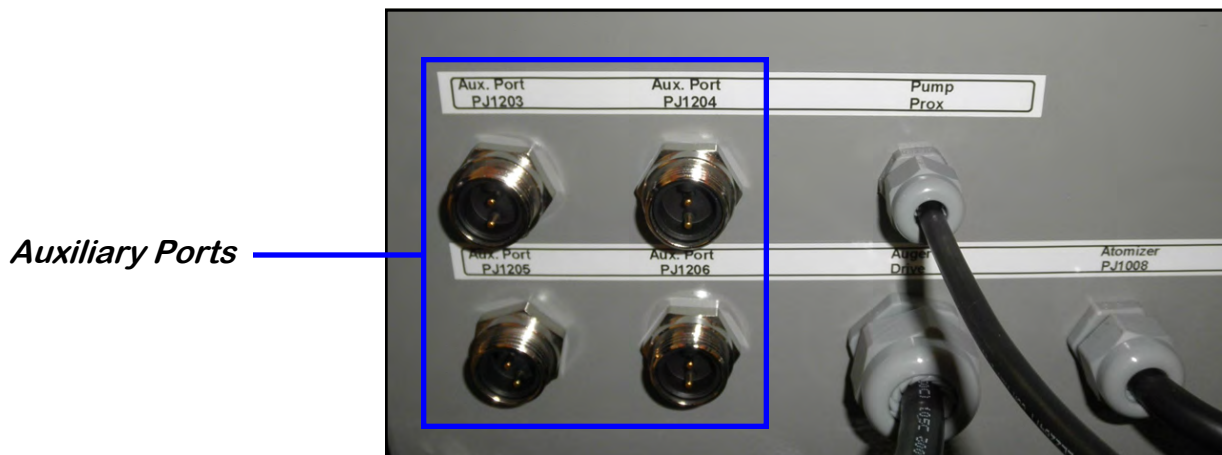

SECTION
E**CALIBRATION****SEED FLOW CALIBRATION**

The following steps illustrate how to calibrate the seed flow for an AT500H series seed treater. A stop watch, ladder, and a known weight of seed will be needed for the calibration process.

1. Position all equipment so that you are able to run a dry batch of seed through the seed treater and catch it back into a container. This will allow you to easily run the seed through again to recalibrate or begin treating. Calibration should be done with at least 2000 lbs. or 40 units.
2. Set the seed gate at a position that you and your equipment can handle. Refer to page 23 for adjusting the seed gate.
3. Place the auger and any conveyors in the ON position.
4. When equipment is in position, begin running the known weight of seed through the seed treater. Using the stop watch, begin timing as soon as the first seed lands in the bottom of the supply hopper.

NOTICE

Ensure the supply hopper stays full at all times. If seed does not pile-up in the hopper, the seed calibration will not be accurate.

5. Stop timing after all seed has left the supply hopper.
6. Calculate the seed flow rate: Total Pounds per Minute.

EXAMPLE: 2000 pounds takes 4 minutes and 18 seconds, or 258 seconds
 $2000 \text{ pounds} / 258 \text{ seconds} = 7.75 \text{ pounds/seconds}$
 $7.75 \times 60 \text{ seconds} = 465 \text{ lbs/minute}$
 $465 / 100 = 4.65 \text{ cwt/min (hundred weight per minute)}$

NOTICE

Different seed sizes and different seed types will tend to flow at varying speeds. Be sure to check calibration when changing to a different seed size or seed type.

WARNING

Do not run the seed at a rate greater than 500 pounds per minute. Running at a rate greater than 500 pounds per minute could cause the auger motor to overload.

ADJUSTING THE SEED FLOW GATE

To adjust the seed flow rate, pull back on the spring-loaded coupling and adjust to the desired notch on the shaft. Below are pictures that illustrate how to open and close the seed flow gate.

When the black lever is pulled down, the seed gate is in the closed position, and will not allow seed to flow through.

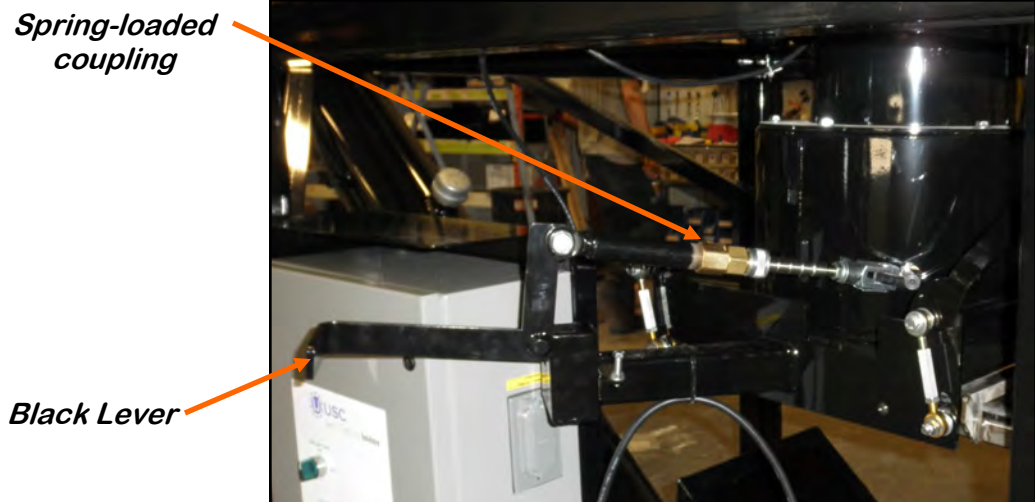

When the black lever is pushed up, the seed gate is in the open position, and seed will flow through.

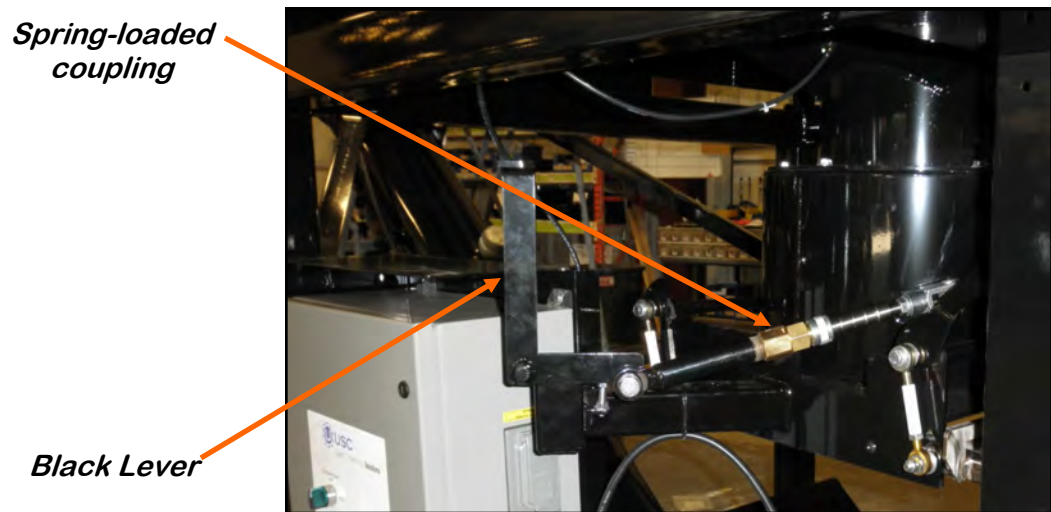

TREATING SEED

1. Position conveyors, overhead hopper, or seed box so the first seed coming into the seed treater lands on the lower proximity switch which automatically turns on the pump(s).
2. Turn the CHEMICAL PUMP switch to AUTO.
3. Turn the switches to ON for the auger.
4. Begin sending seed into the seed treater. As soon as the proximity switch detects seed, the pump will turn on and the seed treating process will begin.

NOTICE

If the first seed is not as well coated, the CHEMICAL PUMP switch can initially be turned to HAND before the seed comes into the treater. Once the surge hopper is full, the switch can be turned to AUTO.

5. When all seed has passed through the Atomizer chamber, the pump will automatically shut off.

Conversion Chart

1 ounce = 29.58 milliliters

1 gallon = 3.79 liters

1 kilogram = 2.2 pounds

1 unit = 50 lbs or 22.73 kg

1 bushel = approx. 60 lbs or 27.27 kg

1 cwt = 100 lbs or 45.45 kg

TROUBLESHOOTING**SECTION
F****TROUBLESHOOTING**

Below is a table describing the most frequent problems and solutions with the USC AT500H Treater . For further assistance, contact the USC Service department at (785) 431-7900.

Problem	Possible Cause	Solution
Pump will not turn off in AUTO when seed runs out.	<ol style="list-style-type: none"> 1. Proximity switch is dirty. 2. Proximity switch is set too sensitive. 	<ol style="list-style-type: none"> 1. Clean proximity switch 2. Adjust the pump proximity switch sensitivity by turning adjustment screw counter-clockwise (page 26).
Pump will not turn on in AUTO	<ol style="list-style-type: none"> 1. Proximity switch is not staying covered. 2. Proximity switch is not sensitive enough. 	<ol style="list-style-type: none"> 1. Make sure proximity switch is staying covered with seed. 2. Adjust pump proximity switch sensitivity by turning the adjustment screw clockwise (page 26).
Auger overload keeps tripping	<ol style="list-style-type: none"> 1. Seed flow is too high. 2. Too much liquid being applied. 	<ol style="list-style-type: none"> 1. Slow down seed flow. 2. Lower the liquid rate.

PROXIMITY SWITCH ADJUSTMENT GUIDE

The proximity switches mounted in the extension ring and the seed wheel detect when seed is present.

The proximity switch located in the extension ring is used to automatically shut off the inlet conveyor when the surge hopper is full. This proximity switch is not present on tower systems.

The proximity switches located in the seed wheel automatically shut off the pump when all seed has left the hopper.

If the proximity switch is not working properly, this can be caused by wear, dust, or even moisture. The first step is to clean the lens of the proximity switch. If this does not solve the problem, the next step would be to adjust the sensitivity of the proximity switch.

The green light indicates the power status. If it is active the device is powered.

The amber light indicates when seed is being detected. If it is active it detects seed, if inactive it does not detect seed.

Using the small screwdriver provided inside the control panel, you can adjust the proximity switch by turning the adjusting screw on the back of the proximity switch.

- Turn Clockwise to make the proximity switch more sensitive.
- Turn Counterclockwise to make the proximity switch less sensitive.

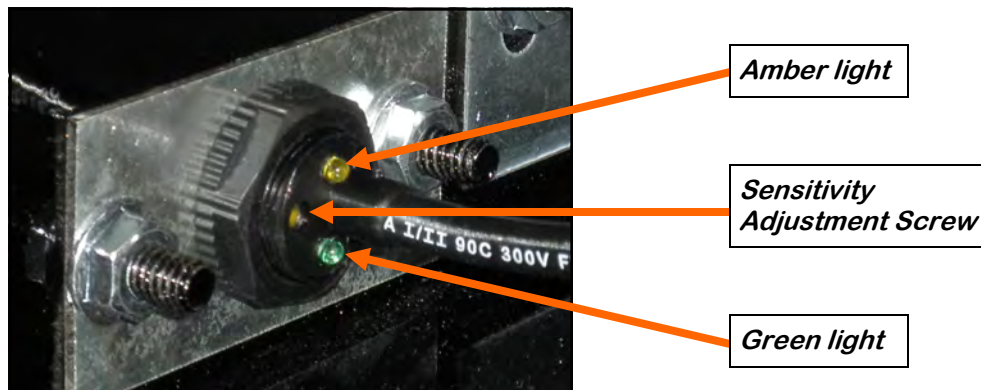

Proximity Switch Screwdriver

MAINTENANCE

SECTION G

Proper maintenance of the AT500H Treater is critical for peak performance, reliability and accuracy of this system. The following is a guideline for the type of maintenance and servicing that should be performed on this unit. Your environment and uses may require additional maintenance and service beyond this list to assure a reliable and safe unit. The operator of this unit has ultimate responsibility to identify areas of concern and rectify them before they become a hazard or safety issue. There is no substitute for a trained, alert operator.



Do not put this unit into operation with any questionably maintained parts. Poor performance or a hazard may occur.

GREASING

Use an SAE multipurpose high temperature grease with extreme pressure (EP) performance. Also acceptable is an SAE multipurpose lithium-based grease.

1. Use a Maintenance Checklist to keep record of all scheduled maintenance.
2. Use a hand-held grease gun for all greasing.
3. Wipe grease fitting with a clean cloth before greasing to avoid injecting dirt and grit.
4. Replace and repair broken fittings immediately.



If fittings will not take grease, remove and clean thoroughly. Also clean lubricant passageway. Replace fitting if necessary.

SEED WHEEL

1. Inspect all welds and structural components for bends, cracks and damage.
2. Remove shields to inspect wheel, brushes and proximity switches.
3. Use compressed air to blow out any seeds and excess build-up that may have occurred during operation.

ELECTRICAL PANEL

- Check and tighten wire connections.
- Check quick connects on bottom of control panel.
- Check to see if relays, timers and/or breakers are tripped.
- Check and set the proximity switches. (page 26).
- Check quick connects on end of Auxiliary cord.
- Check and tighten wire connections.
- Check relay and fuse holder.
- Check power cords for cuts or frays and ensure ground is present.

ATOMIZER

To access the inside of the atomizer housing, disconnect the motor power cable from the atomizer motor, push up on the quick release handle and slide out the atomizer. After completing maintenance, slide the atomizer back into the operating position, pull down quick release handle to lock it in place and reconnect the motor power cord.

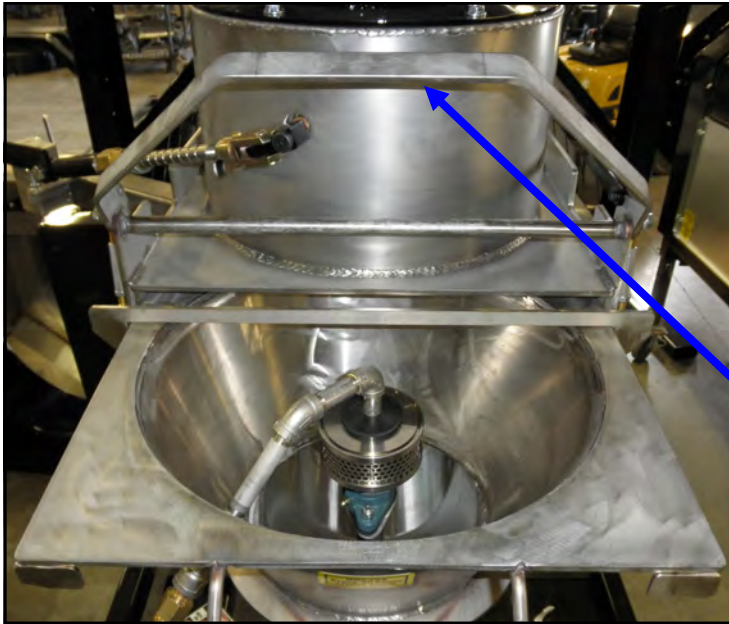

Quick-Release Handle

Atomizer Head

1. Slide out atomizer housing and grease bearing inside. Bearing needs just one pump of grease every 40 hours of operation (right).
2. Clean any build up inside the housing and the atomizer head. To remove the atomizer head, loosen the set screw located on the bottom of the head.
3. Check for any play in the atomizer shaft.
4. Make sure the atomizer spins smoothly.
5. Ensure the adjustable chute is fitting completely into the drum opening. Adjust if necessary.

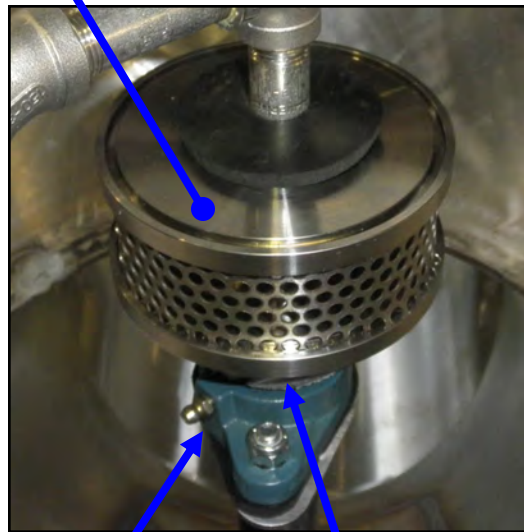

Bearing

Set Screw

DRIVE BELT TENSION & ALIGNMENT

Power to the auger belt is transmitted through a V-belt. The V-belt drive system must be maintained at the proper belt tension and pulley alignment to obtain the desired performance and life. When maintaining the belt drive system for the electric drive model, follow this procedure:

NOTICE Turn motor off and unplug power cord or turn off power and lock out the master panel before starting maintenance on drive belt system.

Drive Belt Tension

1. Push on the center of the belt span with a force of approximately 5 to 10 lbs.
2. Follow the belt tensioning specification on page 30 to determine proper belt deflection.
3. Move the motor up, using the adjustment bolts, to set drive belt tension (right).
4. Close and secure guards.

Drive Belt Alignment

1. Lay a straightedge across the pulley faces to check the alignment (right).
2. Use the pulley hub or the motor mounting plate slots to move the pulley to the required position for alignment.
3. Tighten hub bolts to secure pulley on shaft.
4. Check belt tension
5. Close and secure guards.

Drive Belt Replacement

1. Lower motor to its loosest position.
2. Remove old belt and replace with a new one.
3. Raise motor to set the belt tension.
4. Check pulley alignment. Adjust if required.
5. Close and secure guards.



Motor base adjustment



Lay a straightedge across pulley faces

**SECTION
H**

BELT TENSIONING SPECIFICATION

V-Belt tensioning adjustment can be made using a tension meter or other type spring scale using the following procedure. After seating the belts in the groove and adjusting center distance so as to take up the slack in the belts, further increase the tension until only a slight bow on the slack side is apparent while the drive is operating under load. Stop the drive and using the meter, measure the force necessary to depress one of the center belts 1/64 inch for every inch of belt span (see sketch below). For example, a deflection for a 50 inch belt span is 50/64 or 25/32 inch. The amount of force required to deflect the belt should compare with the deflection forces noted in the table below. Also notice for V- Belts that deflection forces vary from the initial RUN - IN values which are greater (reflecting higher run-in tensioning) to the NORMAL values for after the run-in period.

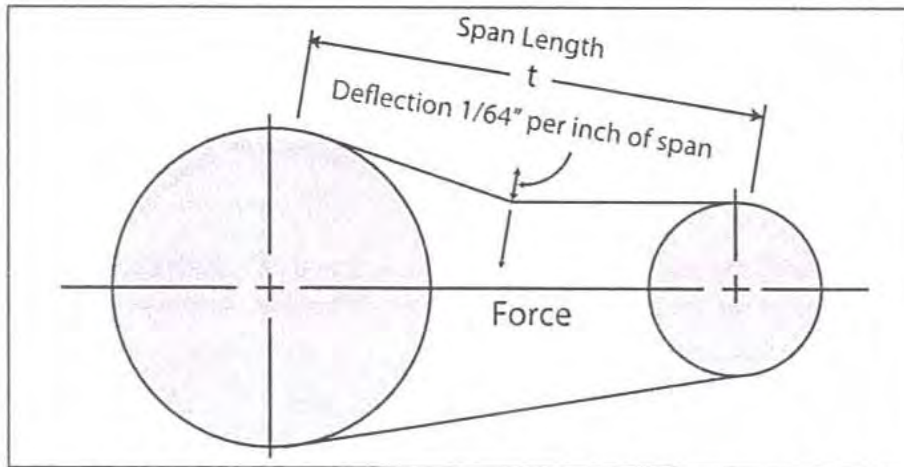

MEASURE THE SPAN LENGTH "T" AS SHOWN IN THE SKETCH ABOVE.

BELT CROSS SECTION	SMALLER PULLEY DIAMETER RANGE (inches)	DEFLECTION FORCE	
		RUN - IN (lbs)	NORMAL (lbs)
AX	3.0 - 3.6	4 - 1/8	2 - 3/4
	3.8 - 4.8	5	3 - 1/4
	5.0 - 7.0	6	4
BX	3.4 - 4.2	5 - 1/4	3 - 1/2
	4.4 - 5.2	7 - 1/8	4 - 3/4
	5.4 - 9.4	9	6

When storing the AT500H Seed Treater for long periods of time, the following procedure must be followed to reduce the chance of rust, corrosion and fatigue of the treater. You can also use these steps when storing the machine for the winter.



A dust mask and protective rubber gloves shall be used when cleaning the machine.

SEEDWHEEL

1. Turn power off to the treater and treater components.
2. Remove shields from the seed wheel and remove any debris or build-up. Compressed air can be used to blow out any foreign material.
3. Turn power back on to the treater and run seed wheel to help remove any additional debris. Compressed air can be used to blow out any foreign material.
4. Check brushes for wear (below).
5. Wipe off and clean the lens of the proximity switches (below).
6. Disconnect power and mount all guard back in place.
7. Tarp or cover the supply hopper and seed wheel to keep out any dirt or unwanted pests.

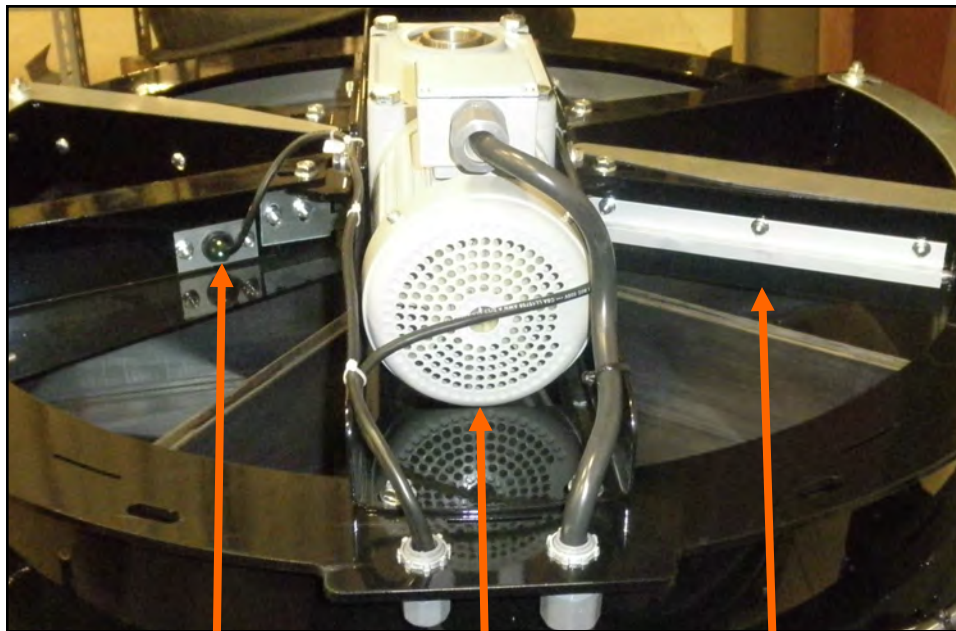

Proximity Switch

Motor

Brush

ATOMIZER CHAMBER

1. Remove and clean the atomizer housing.
2. Remove the atomizer head and stainless steel plumbing. The atomizer head can be disassembled (right), for easier cleaning. It is threaded together and can simply be unscrewed.
3. Reinstall the atomizer head and plumbing. Grease the bearing and spin the atomizer head a few times to ensure all grease has been worked into the bearings.



SUPPLY HOPPER

1. Clean out the supply hopper of any debris (compressed air can be used).
2. Wipe the proximity switch clean.
3. Tarp or cover the hopper to keep out any unwanted pests.

AUGER

1. Grease upper and lower bearings on auger.
2. Remove shield and check tension on belt.
3. Open the bottom clean out door to remove any debris (compressed air can be used).

FINAL

1. Store the machine inside a protective building to keep it from being exposed to the weather.
2. Disconnect power to the machine.
3. Ensure all guards and safety labels are in place.

AT500H TREATER

NOTES:

SECTION
J

MECHANICAL DRAWINGS

STATIC MIXER ASSEMBLY (04-03-0157)

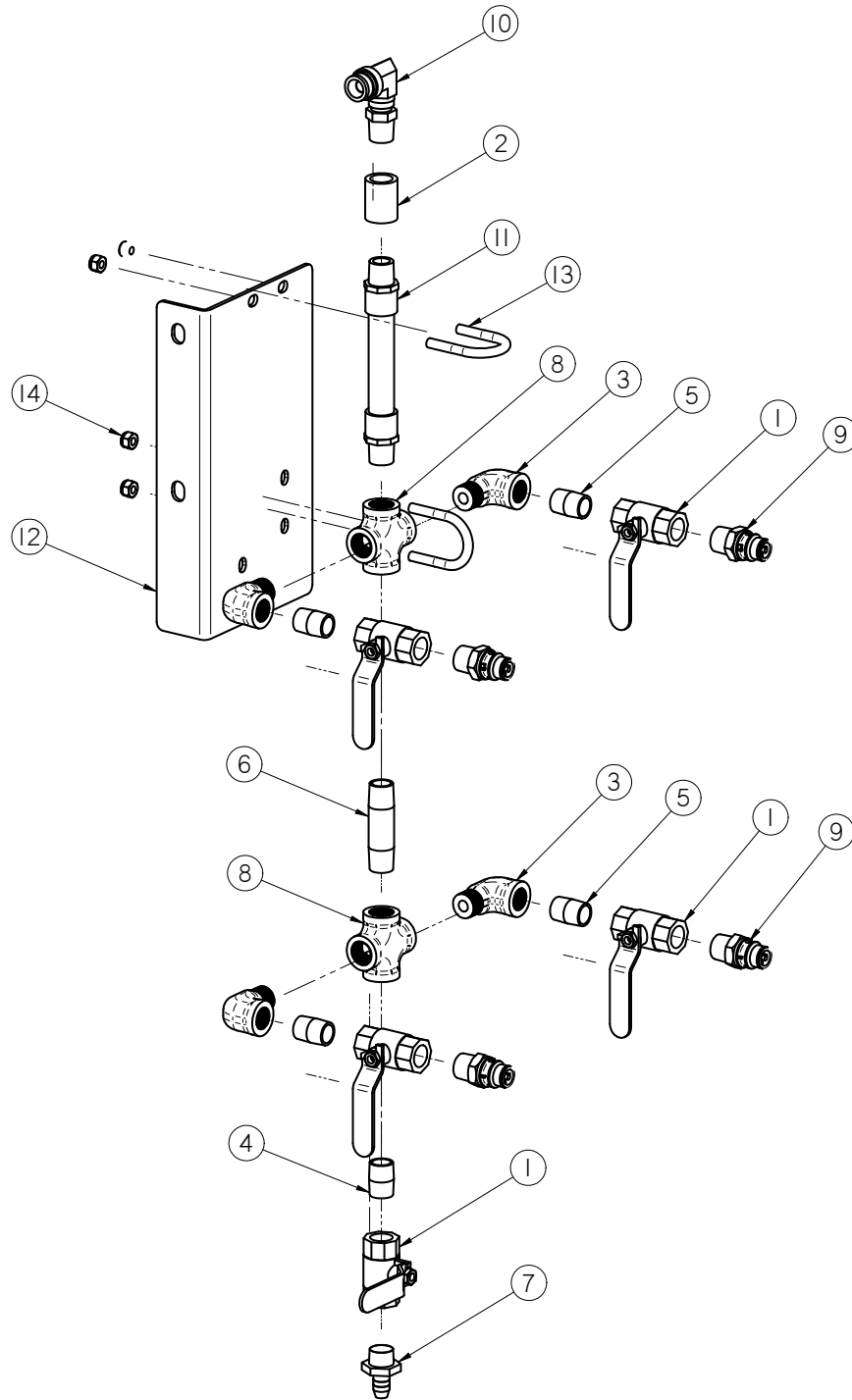

AT500H TREATER

STATIC MIXER ASSEMBLY (04-03-0157)

Item #	Part #	Description	Qty
1	02-02-0006	VLV BALL .500 NPT 2WAY BRSS	5
2	02-05-0005	COUPLER, .500-14 FEMALE,SS 150PSI	1
3	02-06-0020	FTTG 90 DEG STRT .500NPTX .500NPT	4
4	02-07-0007	FTTG NIP .500 NPT X 1.125 TBE SS	1
5	02-07-0007	FTTG NIP .500 NPT X 1.125 TBE SS	4
6	02-07-0019	NIPPLE, .500-14 NPT X 3.0 LG 304SS	1
7	02-08-0007	FTTG STGHT .500HB X .500NPT ML NYL	1
8	02-11-0001	FTTG CROSS .500 NPT FM SS	2
9	02-15-0014	FTTG CPLG .500 NPT QCK DISC INSERT	4
10	02-16-0050	FTTG PUSH 90DEG .625ODX.500 NPT ML	1
11	04-03-0030	MXR IL PVC 6ELEMENT .500PIPE X 7.00	1
12	05-10-2891B	STATIC MIXER & MNFLD MNT BRKT	1
13	06-01-0037	BOLT U .313-18 X 1.38 X 2.188 ZP	2
14	06-03-0002	NUT NYL LOCK .313-18 ZP GR5	4

AT500H TREATER

ADJUSTABLE CHAMBER ASSEMBLY (18-01-0287)

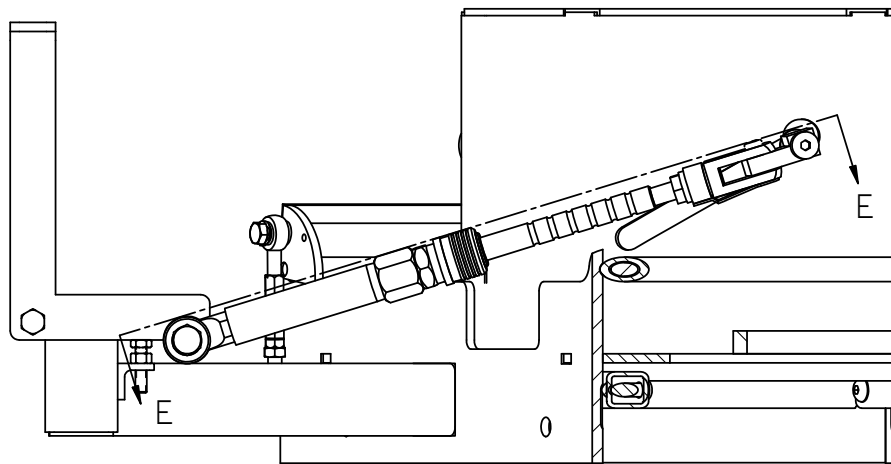
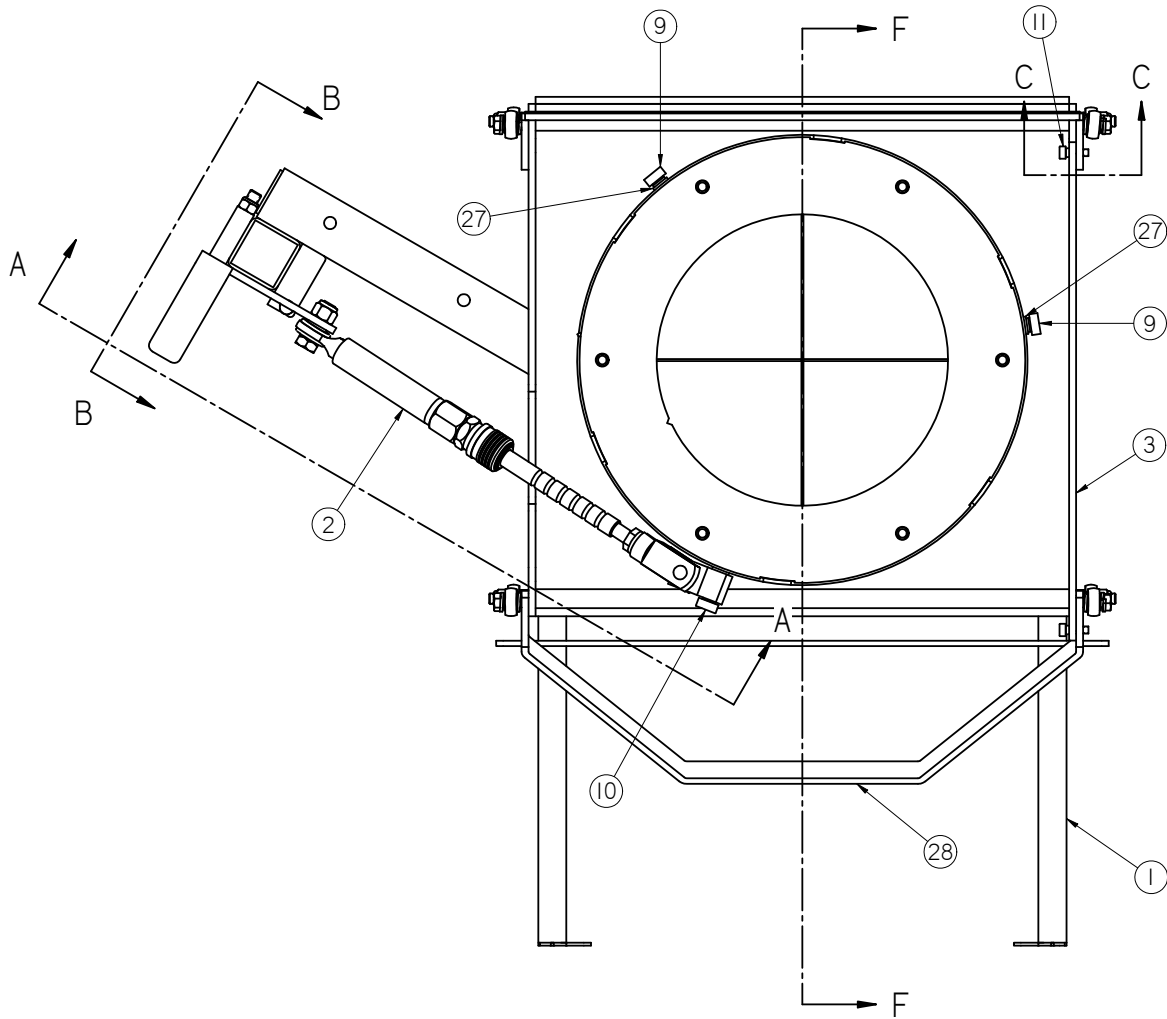

SECTION A-A

AT500H TREATER

ADJUSTABLE CHAMBER ASSEMBLY (18-01-0287)

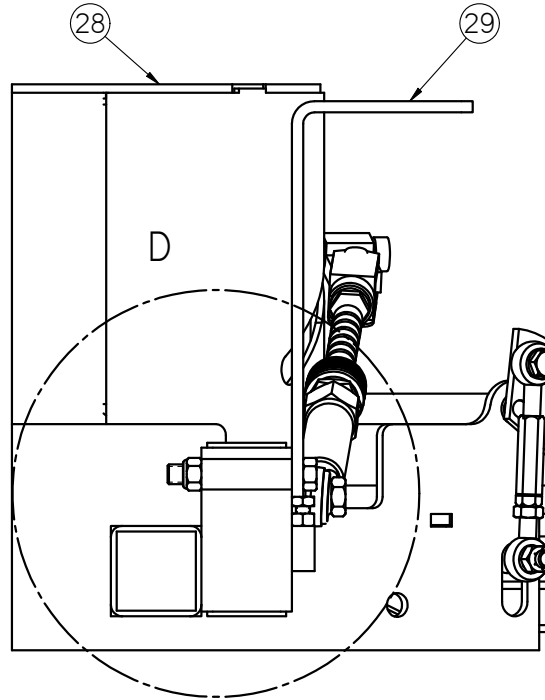

SECTION B-B

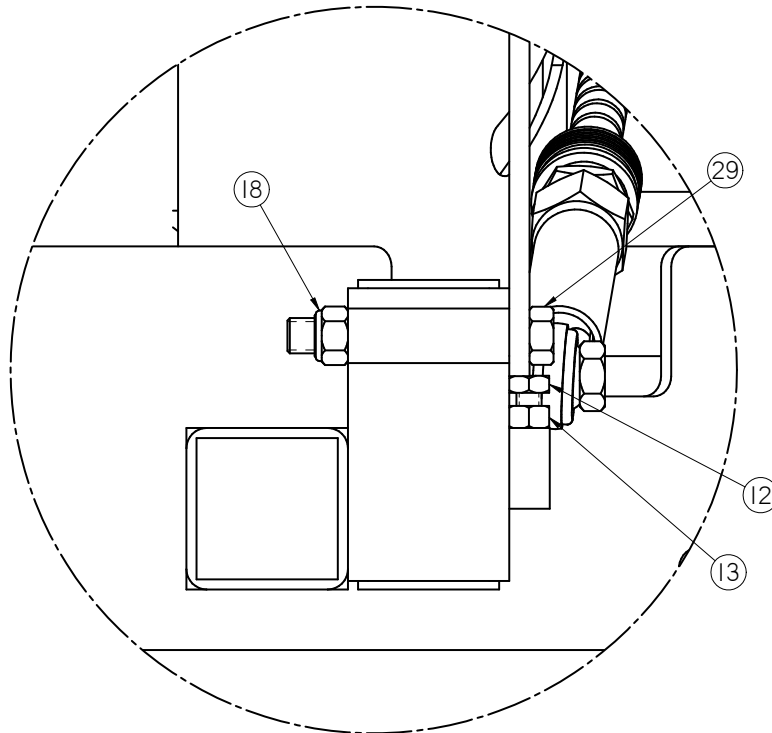

DETAIL D

ADJUSTABLE CHAMBER ASSEMBLY (18-01-0287)

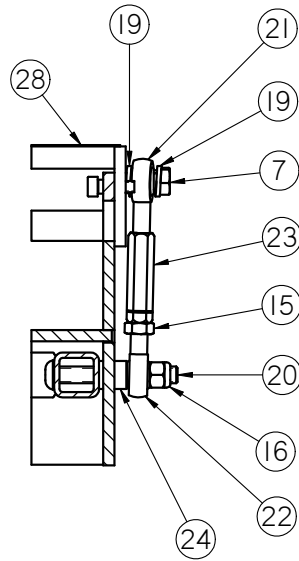

SECTION C-C

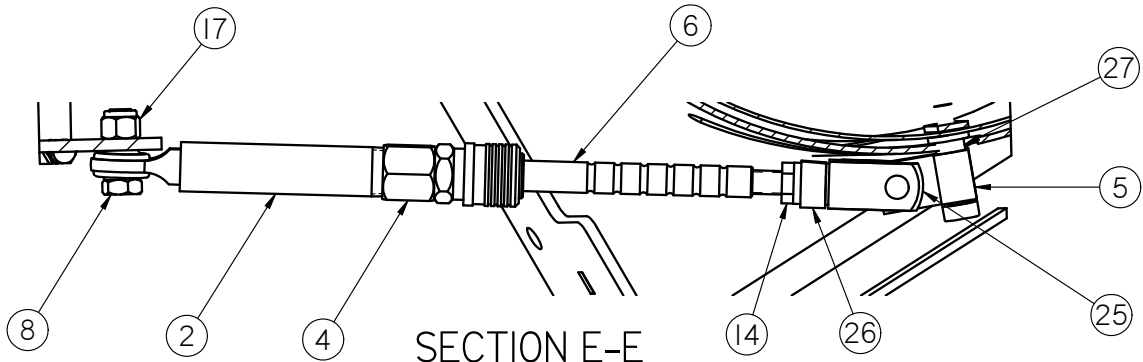

SECTION E-E

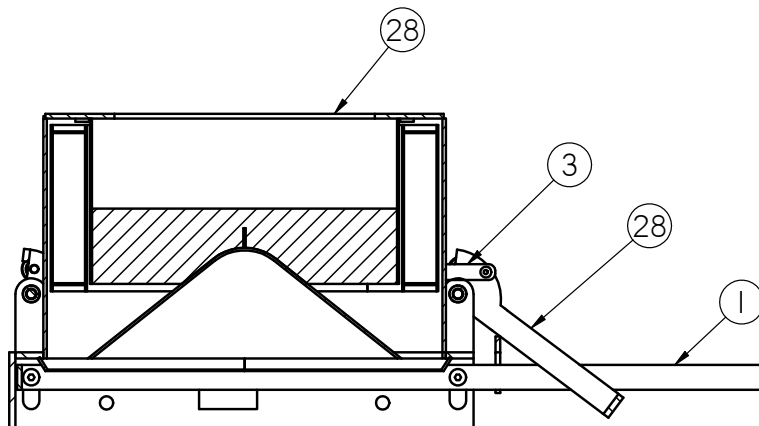

SECTION F-F

AT500H TREATER

ADJUSTABLE CHAMBER ASSEMBLY (18-01-0287)

Item #	Part #	Description	Qty
1	05-03-0336	WDMT,CHAMBER SUPPORT BRK SS	1
2	05-04-0012	WDMT FLOW SLV ROD END TUBE	1
3	5/10/2062	BAR ECNTRC CONNECTING CS	1
4	05-11-0029	CPLG QCK CONNECT MACH	1
5	05-11-0030	BRKT FLOW CNTL CLEVIS	1
6	05-11-0408	ROD FLOW STOP ADJ AT500	1
7	06-01-0016	BOLT .375-16 X 1.00 ZP GR5	4
8	06-01-0025	BOLT .500-13 X 1.50 ZP GR5	1
9	06-01-0056	BOLT SHLD .500SHX.375-16X.500 GR5	2
10	06-01-0057	BOLT SHLD .500SHX.375-16X1.50 GR5	1
11	06-01-0081	BOLT SHLD .313SHX.250-20X.375 GR5	2
12	06-01-0102	BOLT .313-18 X 1.25 ZP GR5	1
13	06-02-0002	NUT FULL .313-18 ZP GR5	1
14	06-02-0015	NUT JAM .500-20 ZP GR5	1
15	06-02-0035	NUT, .375-24 UNF ZP GRADE 5	4
16	06-03-0003	NUT NYL LOCK .375-16 ZP GR5	4
17	06-03-0004	NUT NYL LOCK .500-13 ZP GR5	1
18	06-03-0006	NUT NYL LOCK .438-14 ZP GR5	1
19	06-04-0003	WSHR LOCK SPLT .375 ZP	8
20	06-06-0087	SCRW BTN SCKT HD .375-16X2.75 ZP	4
21	06-12-0002	REND .375-24 BALL RH	4
22	06-12-0003	REND .375-24 BALL RH	4
23	06-12-0006	NUT, .375-24 x 2,ALUM RH_LH CONNECT	4
24	06-12-0007	BUSH DRILL.375ID X .625OD X .625	4
25	06-12-0008	CLVS .500-20 X .500	1
26	06-12-0009	PIN CLIP SPRING .500	1
27	06-12-0012	BUSH FLG BRZ .500ID X .625OD X .375	3
28	18-01-0060	WDMT ADJ CHMBR LPX2000 CS	1
29	18-01-0108	WDMT FLOW SLV HNDL LPX	1

LOSS-IN-WEIGHT ADJUSTABLE CHAMBER ASSEMBLY (18-01-0283)

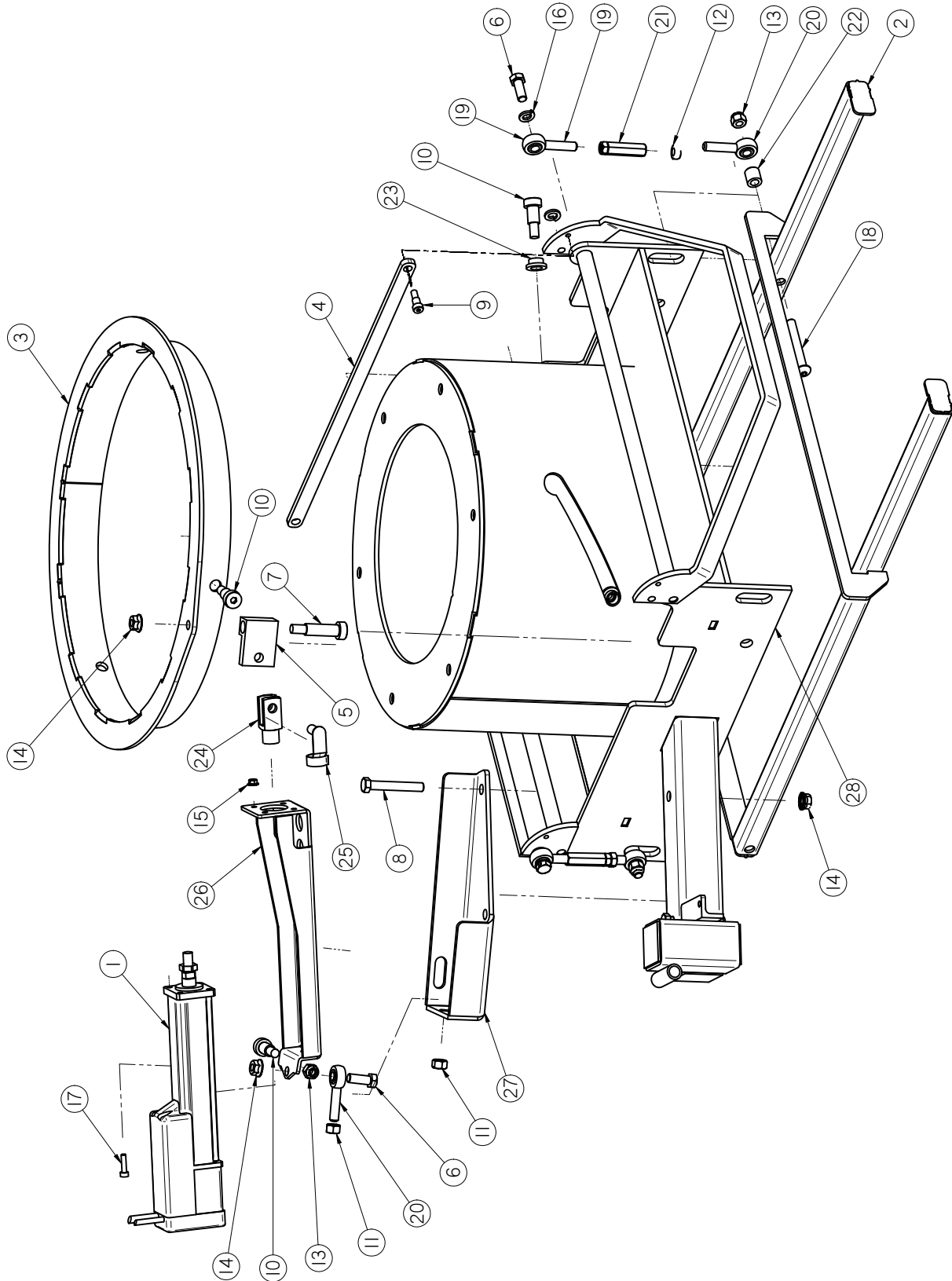

LOSS-IN-WEIGHT ADJUSTABLE CHAMBER ASSEMBLY (18-01-0283)

Item #	Part #	Description	Qty
1	03-20-0162	KIT ACTR W CONNECTORS	1
2	05-03-0336	WDMT,CHAMBER SUPPORT BRK SS	1
3	05-04-0169	WDMT RING DRV LIW SLEEVE	1
4	05-10-2062	BAR ECNTRC CONNECTING CS	1
5	05-11-0394	BRKT FLOW CNTL CLVS 10 MM	1
6	06-01-0016	BOLT .375-16 X 1.00 ZP GR5	5
7	06-01-0057	BOLT SHLD .500SHX.375-16X1.50 GR5	1
8	06-01-0071	BOLT, .375-16 X 2 1/2 ZP G5 FULL THREAD	2
9	06-01-0081	BOLT SHLD .313SHX.250-20X.375 GR5	2
10	06-01-0278	BOLT SHLD .500SHX.375-16X.750 GR5	4
11	06-02-0003	NUT FULL .375-16 ZP GR5	2
12	06-02-0035	NUT, .375-24 UNF ZP GRADE 5	4
13	06-03-0003	NUT NYL LOCK .375-16 ZP GR5	5
14	06-03-0014	NUT LOCK FLG .375-16 ZP GR5	4
15	06-03-0031	NUT LOCK FLG M5-0.8 GR8.8	4
16	06-04-0003	WSHR LOCK SPLT .375 ZP	8
17	06-06-0083	SCRW SH M5-0.8 X 20MM BO	4
18	06-06-0087	SCRW BTN SCKT HD .375-16X2.75 ZP	4
19	06-12-0002	REND .375-24 BALL RH	4
20	06-12-0003	REND .375-24 BALL RH	5
21	06-12-0006	NUT,.375-24 x 2,ALUM RH_LH CONNECT	4
22	06-12-0007	BUSH DRILL.375ID X .625OD X .625	4
23	06-12-0012	BUSH FLG BRZ .500ID X .625OD X .375	3
24	06-12-0043	CLVS 10-1.25 X 10MM	1
25	06-12-0044	PIN CLIP SPRING 10MM	1
26	102EEA	BRKT DYATIC SCN5-010-150 ACTUATOR	1
27	102EEB	BRKT CYL BASE	1
28	18-01-0060	WDMT ADJ CHMBR LPX2000 CS	1

AT500H TREATER

ATOMIZER ASSEMBLY (18-01-0282)

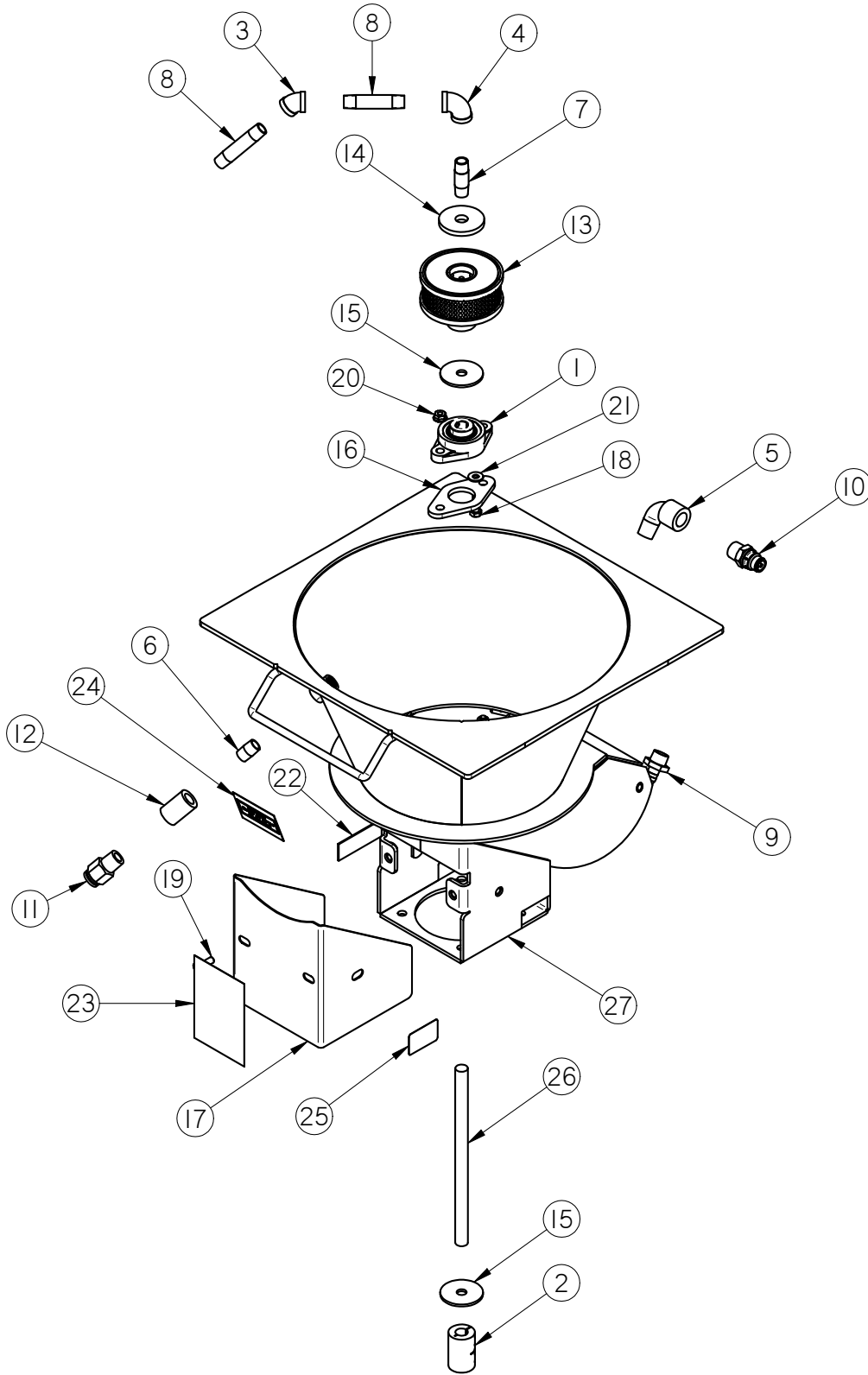

AT500H TREATER

ATOMIZER ASSEMBLY (18-01-0282)

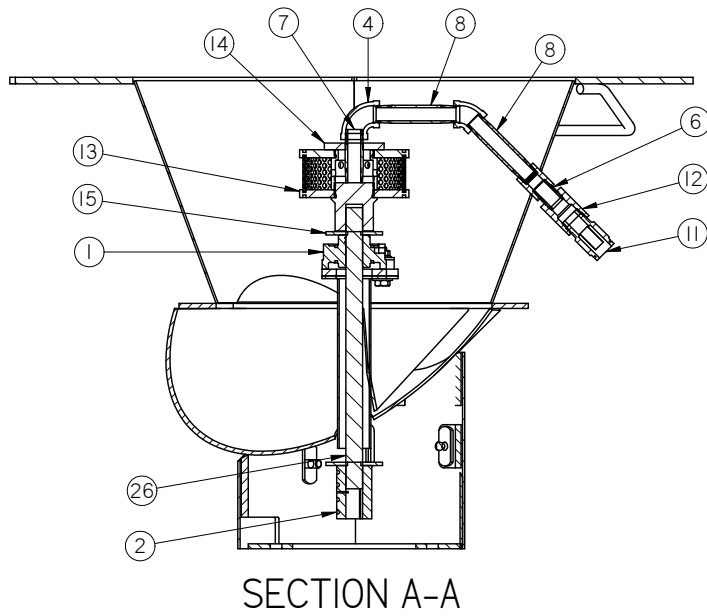
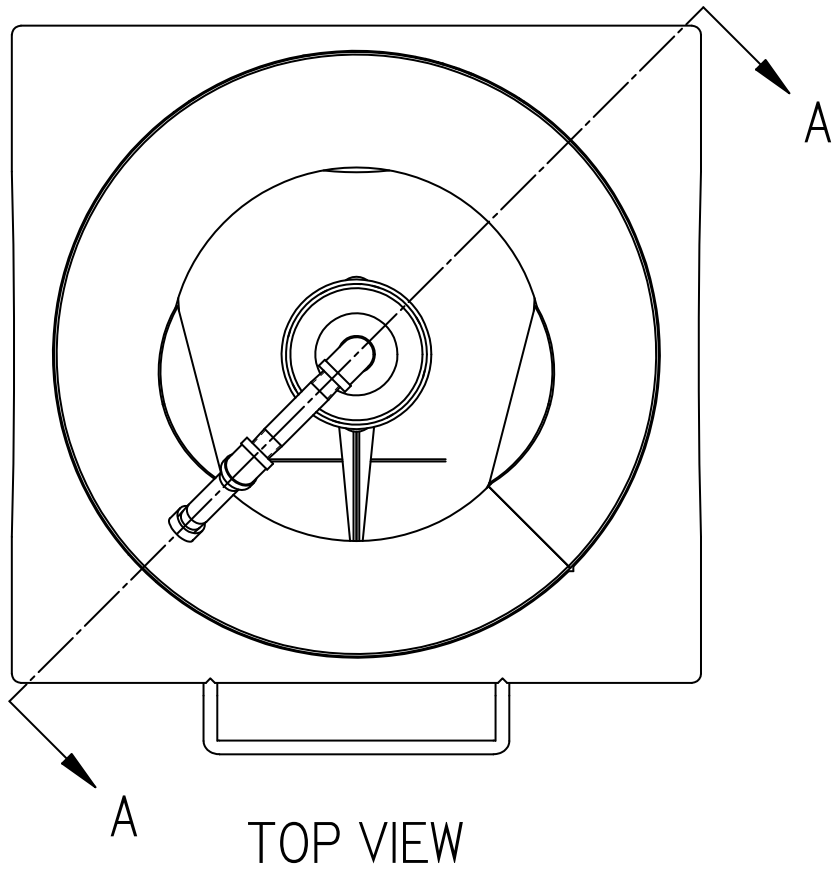

AT500H TREATER

ATOMIZER ASSEMBLY (18-01-0282)

Item #	Part #	Description	Qty
1	01-03-0002	BRG FLG MNT .625ID 3.875 BASE	1
2	01-07-0027	CPLG CLPN .625 X .625 SPLT CS	1
3	02-06-0007	ELBOW, .375-18 NPT, 45 DEG. SS	1
4	02-06-0008	FTTG 90 DEG .375NPT FM SS	1
5	02-06-0017	1/2-14 NPT,SL 90 DEG. BP	1
6	02-07-0001	NIPPLE, .375 NPT SCH. 40 304 SS	1
7	02-07-0003	FTTG NIP .375 NPT X 2.00 TBE SS	1
8	02-07-0020	NIPPLE, 3/8-18 NPT X 3.00 SS	2
9	02-08-0007	FTTG STGHT .500HB X .500NPT ML NYL	1
10	02-15-0014	FTTG CPLG .500 NPT QCK DISC INSERT	1
11	02-16-0028	FTTG PUSH .625OD X .500 NPT ML	1
12	02-16-0052	FTTG CPLG RDCG .500NPT X .375NPT SS	1
13	04-02-0004	ASSY,ATOMIZER HEAD,4" COTTON	1
14	05-10-0360	DISC STD ATMZR HEAD CVR	1
15	05-10-0805	DISK ATOMIZER MOTOR	2
16	05-10-2462	SEAL RBBR .625 FLG BRG	1
17	05-10-2816	LP2000 MTR GUARD FLEX CPLG	1
18	06-01-0102	BOLT .313-18 X 1.25 ZP GR5	2
19	06-01-0124	BOLT, FLG .375-16 UNC ZP GRADE 5; 3/4" LG	4
20	06-03-0019	NUT LOCK FLG .3125-18 ZP GR5	2
21	06-05-0001	WASHER, FLAT .250	2
22	09-01-0107	LBL ATWK PATENT DECAL-ATMZR	1
23	09-02-0002	ATWK LBL DANGER GUARDS	1
24	09-02-0004	ATWK LBL GRS 40HRS	1
25	09-02-0013	ATWK LBL ROTATION ARROW	1
26	101FAF	SHAFT DRV ATMZR LPX2000	1
27	18-01-0065	WDMT ATMZR LPX2000 CS	1

AT500H TREATER

SEED WHEEL ASSEMBLY (13-04-0161)

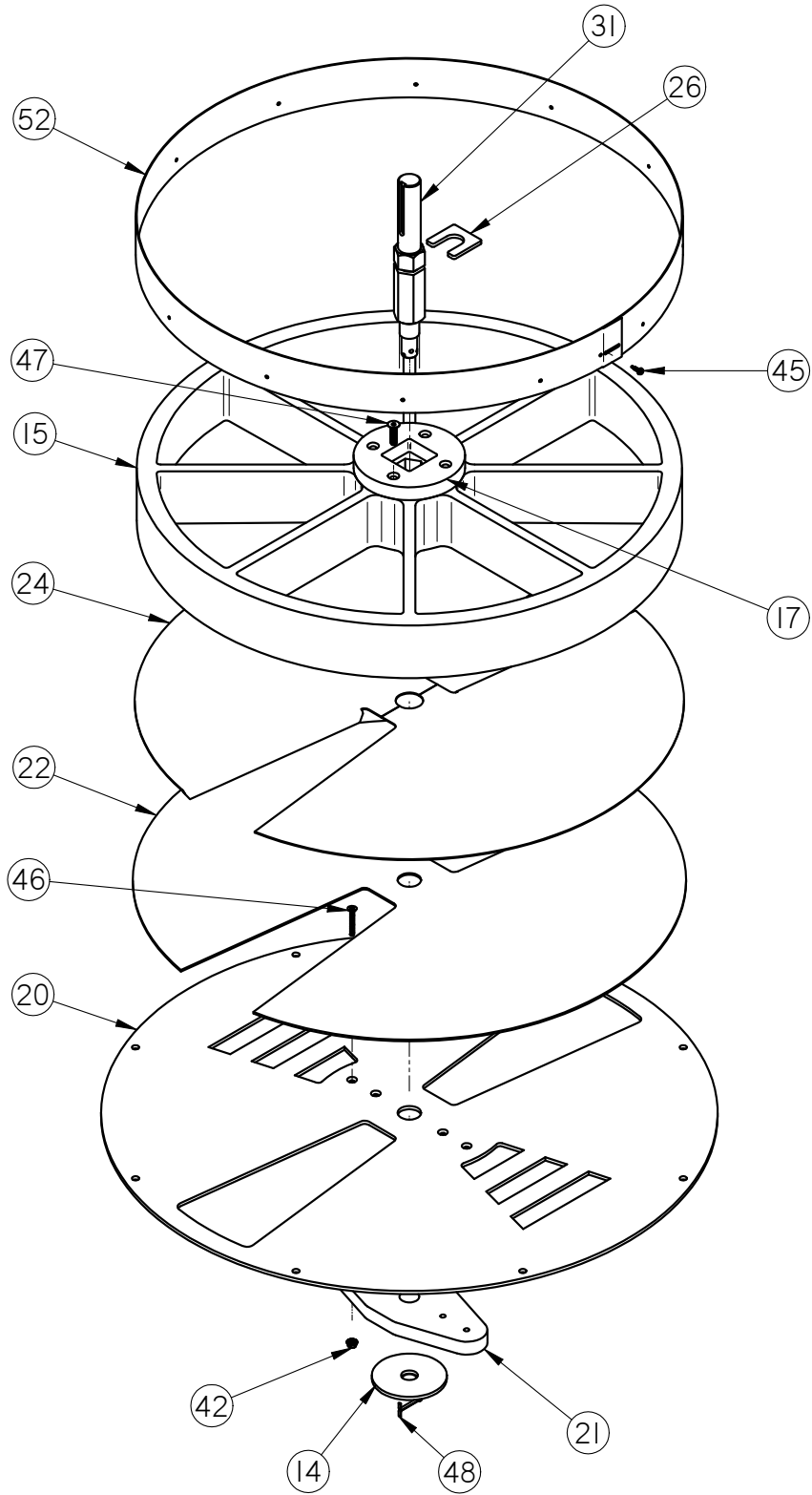

SEED WHEEL ASSEMBLY (13-04-0161)

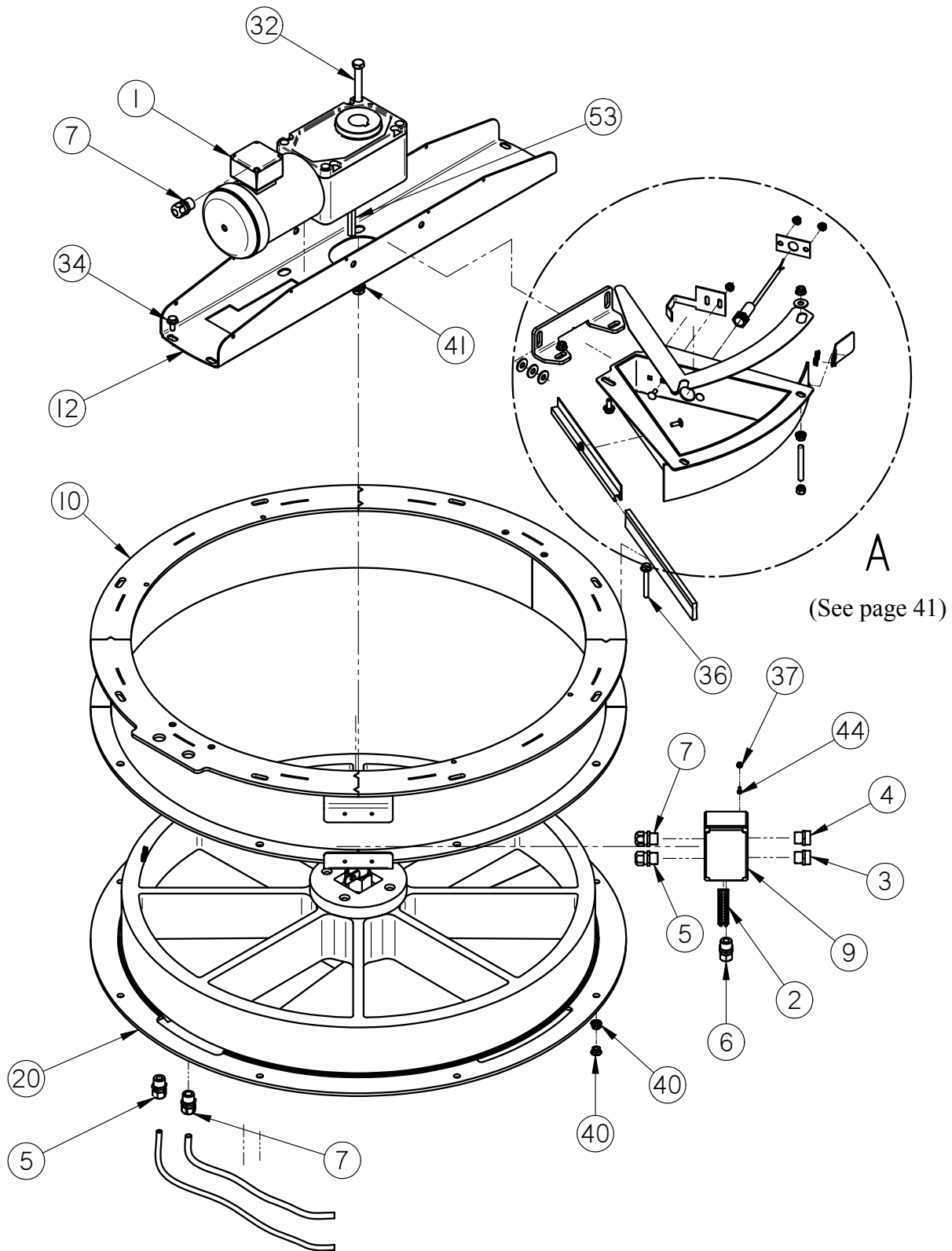

SEED WHEEL ASSEMBLY (13-04-0161)

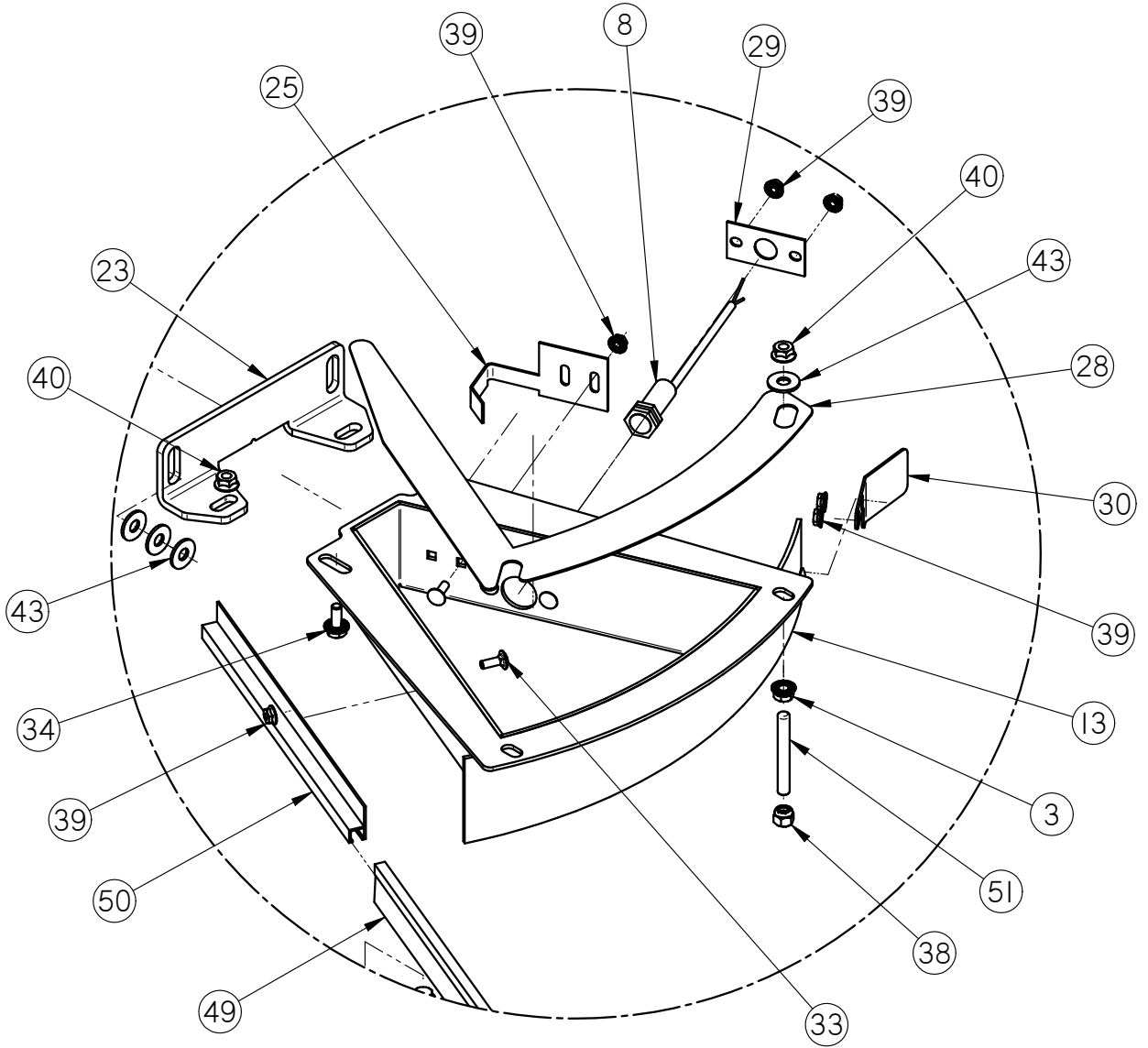

DETAIL A

SEED WHEEL ASSEMBLY (13-04-0161)

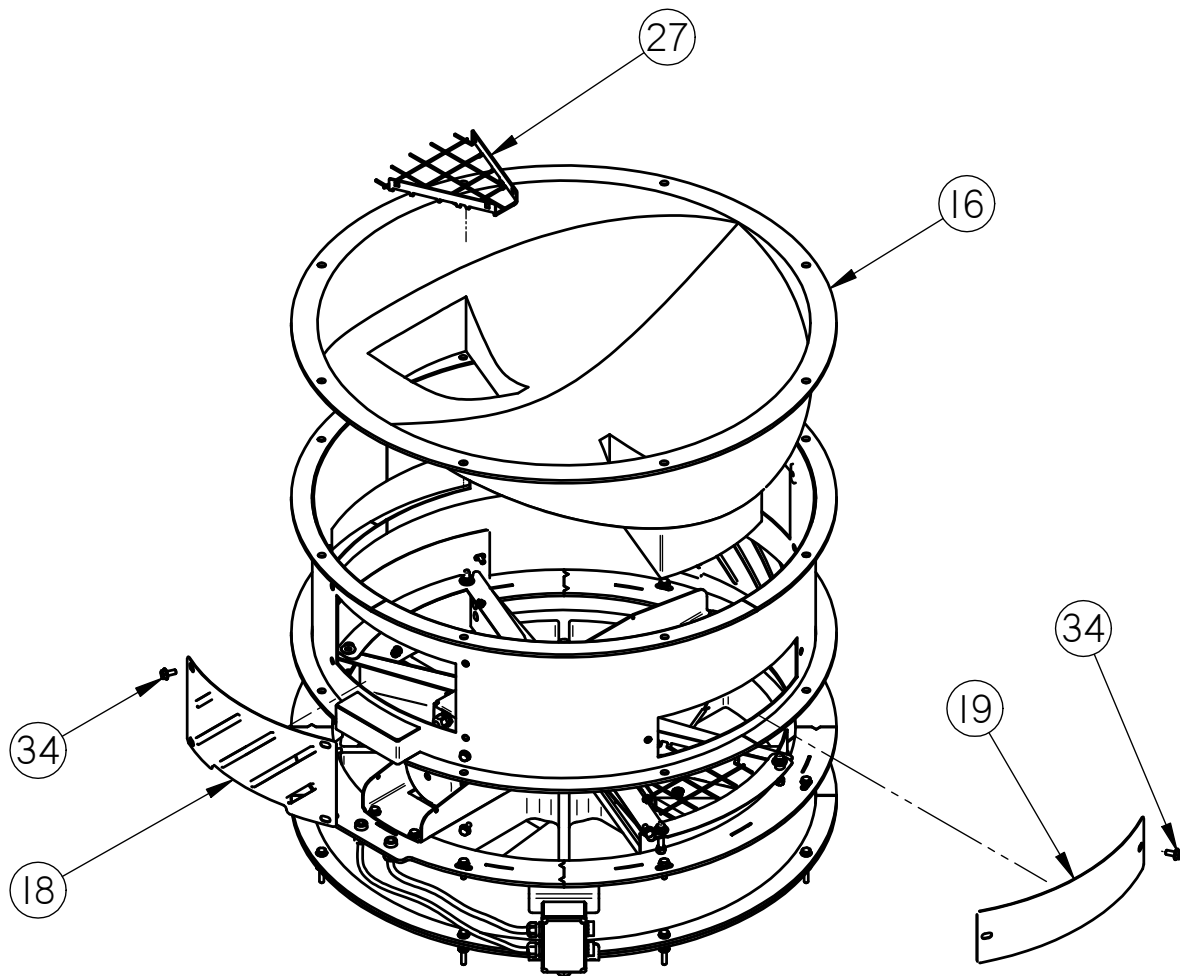

AT500H TREATER

SEED WHEEL ASSEMBLY (13-04-0161)

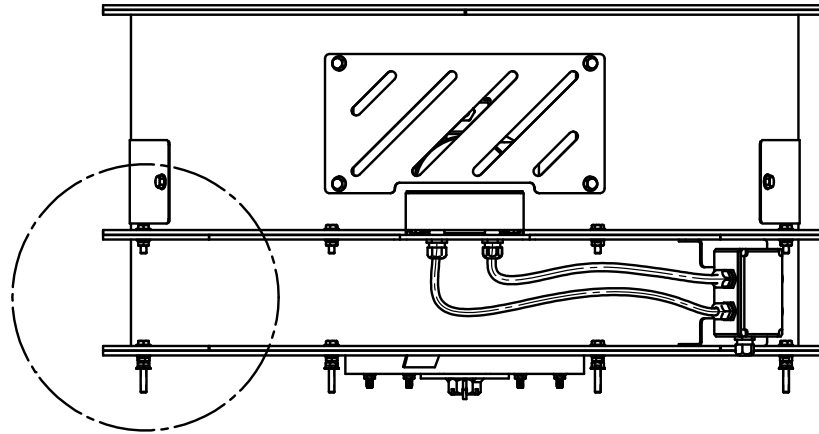

B

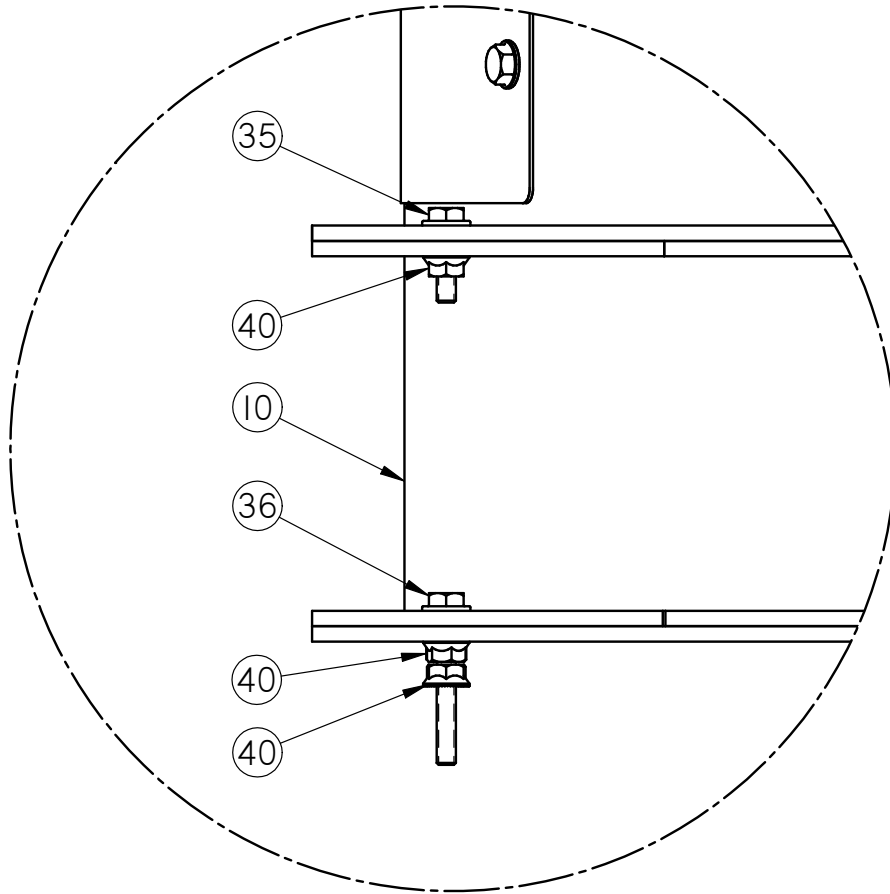

DETAIL B

AT500H TREATER

SEED WHEEL ASSEMBLY (13-04-0161)

Item #	Part #	Description	Qty
1	01-01-0096	GMTR RA .50 HP 11RPM 3PH HLLW SHAFT	1
2	03-05-0042	TMNL BARRIER STRIP IDEAL 89-608	1
3	03-06-0059	RECP 8PL ML PIN HBMS08501	1
4	03-06-0101	RECP 4PL ML PIN HBMS04501	1
5	03-08-0064	CONN CG PLASTIC 0.5NPT .200-.472	2
6	03-08-0134	CONN CG PLAS 0.5NPT .100-.300	1
7	03-08-0138	CONN CG PLAS 0.5NPT .375-.750	3
8	03-10-0051	SENS PROX 24-240 AC AB 875CPG8N18A2	2
9	03-11-0081	ENCL 4.5X3X2 POLY HOF Q1286PCD	1
10	05-03-0164	WDMT SEED METER BODY EXTEN	1
11	05-03-0169	WDMT SEED METER EXTENSION	1
12	05-03-0232	WDMT SMW UPPER BRG BRKT	1
13	05-03-0240	WDMT SMW BRSH PCKT	2
14	05-04-0049	WDMT SEED WHEEL SHAFT NUT	1
15	05-07-0196	MOLDED SEED WHEEL INSERT	1
16	05-07-0197	HPPR SMW DUAL DSCHG ROTO-MLDD	1
17	05-07-0203	MOLDED SEED WHEEL INSERT TOP	1
18	05-10-0890	CVR #1 SEED METER	2
19	05-10-0891	CVR #2 SEED METER	2
20	05-10-0893	PLATE SUPPORT SEED METER STEEL	1
21	05-10-1213	SUPP BTM BRG UHMW SEED METER	1
22	05-10-1306	PAD SEED WHL FOAM RBBR FLOATING	1
23	05-10-1392	BRKT SMW BRSH PCKT HLDR	2
24	05-10-1426	14GA WEAR SPLATE HALF	2
25	05-10-1449	PLT SMW CTR HUB WIPER	2
26	05-10-1588	PLT SHAFT CLIP SMW	1
27	05-10-1872	GRD SMW INLET HOPP PCKT	2
28	05-10-2166	CVR TEST	2
29	05-10-3316	SMW PROX SW HOLDER	2
30	05-10-4192	PLT SMW POCKET SCRAPER	2
31	05-11-0075	DRIVE SHAFT 1.4375 SHAFT	1
32	06-01-0106	BOLT .500-13 X 5.50 ZP GR5	1
33	06-01-0122	BOLT, CARRIAGE, .250-20x.75 G5 ZP	18
34	06-01-0124	BOLT, FLG .375-16 UNC ZP GRADE 5; 3/4" LG	18
35	06-01-0189	BOLT, FLG .375-16 UNC ZP GRADE 5; 1-1/4" LG	1

AT500H TREATER

SEED WHEEL ASSEMBLY (13-04-0161)

Item #	Part #	Description	Qty
36	06-01-0204	BOLT FLG .375-16 X 2.50 ZP GR5 FTH	8
37	06-02-0034	NUT 8-32 K-LOCK ZP	1
38	06-03-0003	NUT NYL LOCK .375-16 ZP GR5	3
39	06-03-0013	NUT,LOCK, FLG .250-20 ZP SERRATTED	26
40	06-03-0014	NUT LOCK FLG .375-16 ZP GR5	13
41	06-03-0015	NUT LOCK FLG .500-13 ZP GR5	1
42	06-03-0019	NUT LOCK FLG .3125-18 ZP GR5	1
43	06-05-0004	WSHR FLAT .375 ZP	10
44	06-06-0004	SCRW MACH 8-32 X .500 PHLP RDHD ZP	1
45	06-06-0023	SCRW, SELF TAPPING, 10-16 ZP X .750	14
46	06-06-0046	SCRW .313-18 X 2.0 ZP FLAT HD PHLP	1
47	06-06-0070	SCRW MACH .375-16 X 1.50 SH FLHD BO	1
48	06-09-0023	PIN CTTR .188 X 2.00 ZP	1
49	06-10-0019	SEAL BRSH 12.75 OAL 1IN EXP LG	2
50	06-10-0020	12 IN LG BRUSH HOLDER	2
51	06-14-0013	.375-16 THD RD CS	3
52	101BC9	PSM SMW GALV RING	1
53	11-13-0004	KEYSTOCK 3/8 X 3/8 CS	1

AT500H TREATER

PRO BOX TOP ASSEMBLY (13-01-0303)

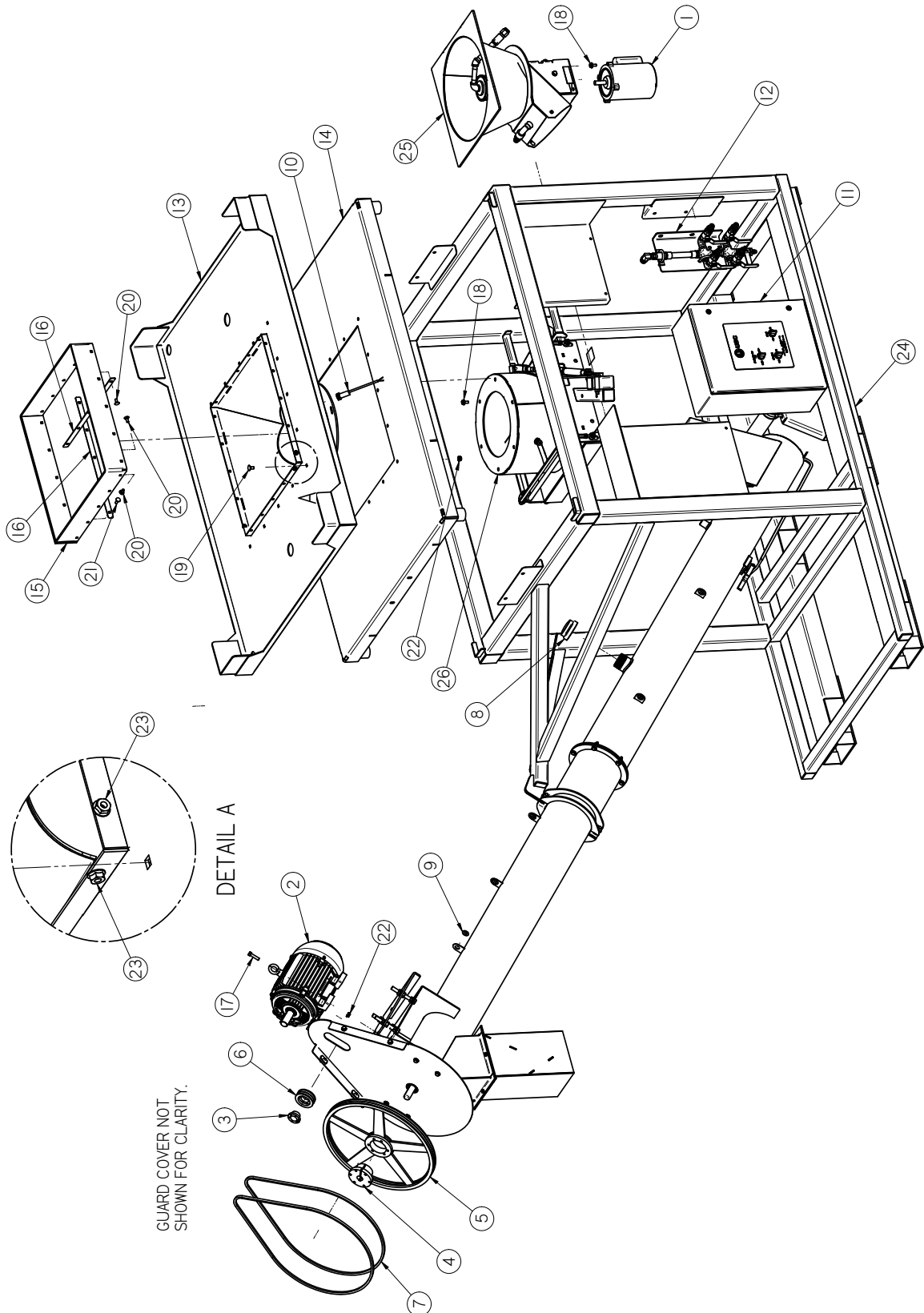

AT500H TREATER

PRO BOX TOP ASSEMBLY (13-01-0303)

Item #	Part #	Description	Qty
1	01-01-0104	MTR .33HP 1725RPM 56C 1PH TENV	1
2	01-01-0127	MTR 3HP 1750RPM 184T TEFC 1PH	1
3	01-08-0029	Bushing JA 1.125	1
4	01-08-0037	BUSHING SK 1.00	1
5	01-08-0070	SHV 3V19.00X2 SK	1
6	01-08-0071	SHV 3V3.0X2 JA	1
7	01-08-0072	BELT 3VX670	2
8	02-14-0022	FTTG END CAP 2IN NPT 125PSI ZP/GALV	1
9	03-09-0015	GRMT RBBR .500ID X 1.00OD X .750KO	5
10	03-10-0051	SENS PROX 24-240 AC AB 875CPG8N18A2	1
11	03-12-0378	AT500H CONTROL PANEL	1
12	04-03-0157	ASSY STTC MXR & VLVS LPX TRTR	1
13	05-07-0747	WDMT HOPP SCALE GUIDE AT500 LIW	1
14	05-08-0399	WDMT SUB 5 X 4 LIW SCL	1
15	05-10-4270	GUIDE RBBR LIW SCALE HOPP	1
16	05-10-4271	PLT CLAMP HOPP FLEX INLET	4
17	06-01-0018	BOLT .375-16 X 1.50 ZP GR5	4
18	06-01-0124	BOLT, FLG .375-16 UNC ZP GRADE 5; 3/4" LG	14
19	06-01-0153	BOLT CRG .375-16X.750 ZP SHORT NECK	18
20	06-01-0171	BOLT CRG .3125-18X.750 ZP SHORT NECK	7
21	06-01-0223	BOLT CRG .313-18 X 1.00 ZP GR5	5
22	06-03-0014	NUT LOCK FLG .375-16 ZP GR5	26
23	06-03-0019	NUT LOCK FLG .3125-18 ZP GR5	12
24	13-11-0032	ASSY BASE AT500 LIW 144IN AUGER	1
25	18-01-0282	ASSY ATMZR AT500 LIW CS	1
26	18-01-0287	ASSY ADJ CHMBR AT500	1

AT500H TREATER

LOSS-IN-WEIGHT TOP ASSEMBLY (13-01-0304)

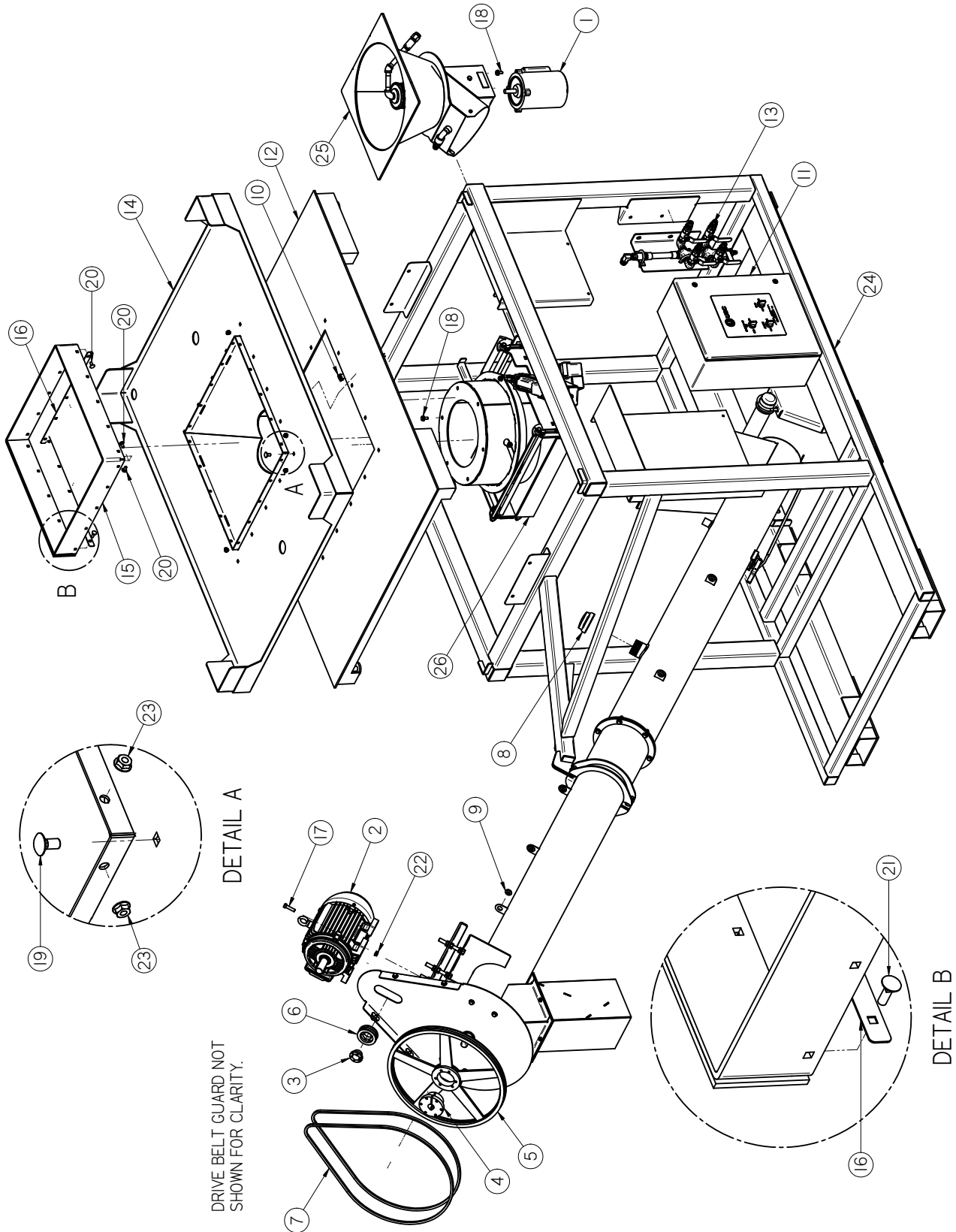

DRIVE BELT GUARD NOT SHOWN FOR CLARITY.

AT500H TREATER

LOSS-IN-WEIGHT TOP ASSEMBLY (13-01-0304)

Item #	Part #	Description	Qty
1	01-01-0104	MTR .33HP 1725RPM 56C 1PH TENV	1
2	01-01-0127	MTR 3HP 1750RPM 184T TEFC 1PH	1
3	01-08-0029	Bushing JA 1.125	1
4	01-08-0037	BUSHING SK 1.00	1
5	01-08-0070	SHV 3V19.00X2 SK	1
6	01-08-0071	SHV 3V3.0X2 JA	1
7	01-08-0072	BELT 3VX670	2
8	02-14-0022	FTTG END CAP 2IN NPT 125PSI ZP/GALV	1
9	03-09-0015	GRMT RBBR .500ID X 1.00OD X .750KO	5
10	03-10-0051	SENS PROX 24-240 AC AB 875CPG8N18A2	1
11	03-12-0378	AT500H CONTROL PANEL	1
12	03-19-0066	SCL 5X4FT 5K 2FT CTR CUTOUT*	1
13	04-03-0157	ASSY STTC MXR & VLVS LPX TRTR	1
14	05-07-0747	WDMT HOPP SCALE GUIDE AT500 LIW	1
15	5/10/4270	GUIDE RBBR LIW SCALE HOPP	1
16	5/10/4271	PLT CLAMP HOPP FLEX INLET	4
17	06-01-0018	BOLT .375-16 X 1.50 ZP GR5	4
18	06-01-0124	BOLT, FLG .375-16 UNC ZP GRADE 5; 3/4" LG	10
19	06-01-0153	BOLT CRG .375-16X.750 ZP SHORT NECK	16
20	06-01-0171	BOLT CRG .3125-18X.750 ZP SHORT NECK	7
21	06-01-0223	BOLT CRG .313-18 X 1.00 ZP GR5	5
22	06-03-0014	NUT LOCK FLG .375-16 ZP GR5	20
23	06-03-0019	NUT LOCK FLG .3125-18 ZP GR5	12
24	13-11-0032	ASSY BASE AT500 LIW 144IN AUGER	1
25	18-01-0282	ASSY ATMZR AT500 LIW CS	1
26	18-01-0283	ASSY ADJ CHMBR LIW SO ATMZR 2000 CS	1

SEED METERING WHEEL TOP ASSEMBLY (13-01-0306)

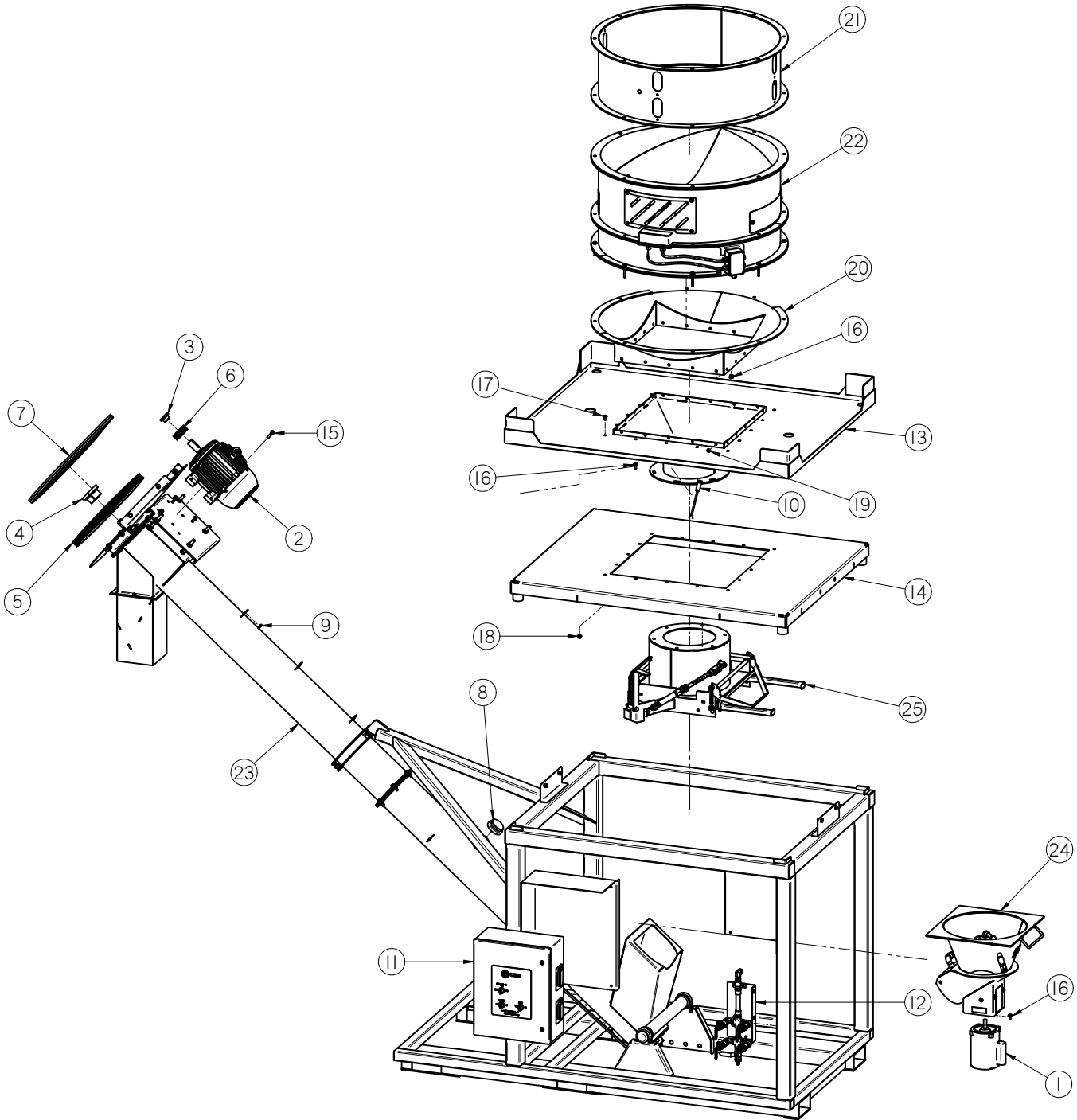

AT500H TREATER

SEED METERING WHEEL TOP ASSEMBLY (13-01-0306)

Item #	Part #	Description	Qty
1	01-01-0104	MTR .33HP 1725RPM 56C 1PH TENV	1
2	01-01-0127	MTR 3HP 1750RPM 184T TEFC 1PH	1
3	01-08-0029	Bushing JA 1.125	1
4	01-08-0037	BUSHING SK 1.00	1
5	01-08-0070	SHV 3V19.00X2 SK	1
6	01-08-0071	SHV 3V3.0X2 JA	1
7	01-08-0072	BELT 3VX670	2
8	02-14-0022	FTTG END CAP 2IN NPT 125PSI ZP/GALV	1
9	03-09-0015	GRMT RBBR .500ID X 1.00OD X .750KO	5
10	03-10-0051	SENS PROX 24-240 AC AB 875CPG8N18A2	1
11	03-12-0378	AT500H CONTROL PANEL	1
12	04-03-0157	ASSY STTC MXR & VLVS LPX TRTR	1
13	05-07-0747	WDMT HOPP SCALE GUIDE AT500 LIW	1
14	05-08-0399	WDMT SUB 5 X 4 LIW SCL	1
15	06-01-0018	BOLT .375-16 X 1.50 ZP GR5	4
16	06-01-0124	BOLT, FLG .375-16 UNC ZP GRADE 5; 3/4" LG	42
17	06-01-0153	BOLT CRG .375-16X.750 ZP SHORT NECK	18
18	06-03-0014	NUT LOCK FLG .375-16 ZP GR5	26
19	06-03-0019	NUT LOCK FLG .3125-18 ZP GR5	26
20	10382A	SMW ADAPTER	1
21	13-04-0043	ASSY EXT HOPP LP800-2000 12IN	1
22	13-04-0158	ASSY SEED METER WHL LP2000 UL	1
23	13-11-0032	ASSY BASE AT500 LIW 144IN AUGER	1
24	18-01-0282	ASSY ATMZR AT500 LIW CS	1
25	18-01-0287	ASSY ADJ CHMBR AT500	1

AT500H TREATER

HOPPER TOP ASSEMBLY (13-01-0307)

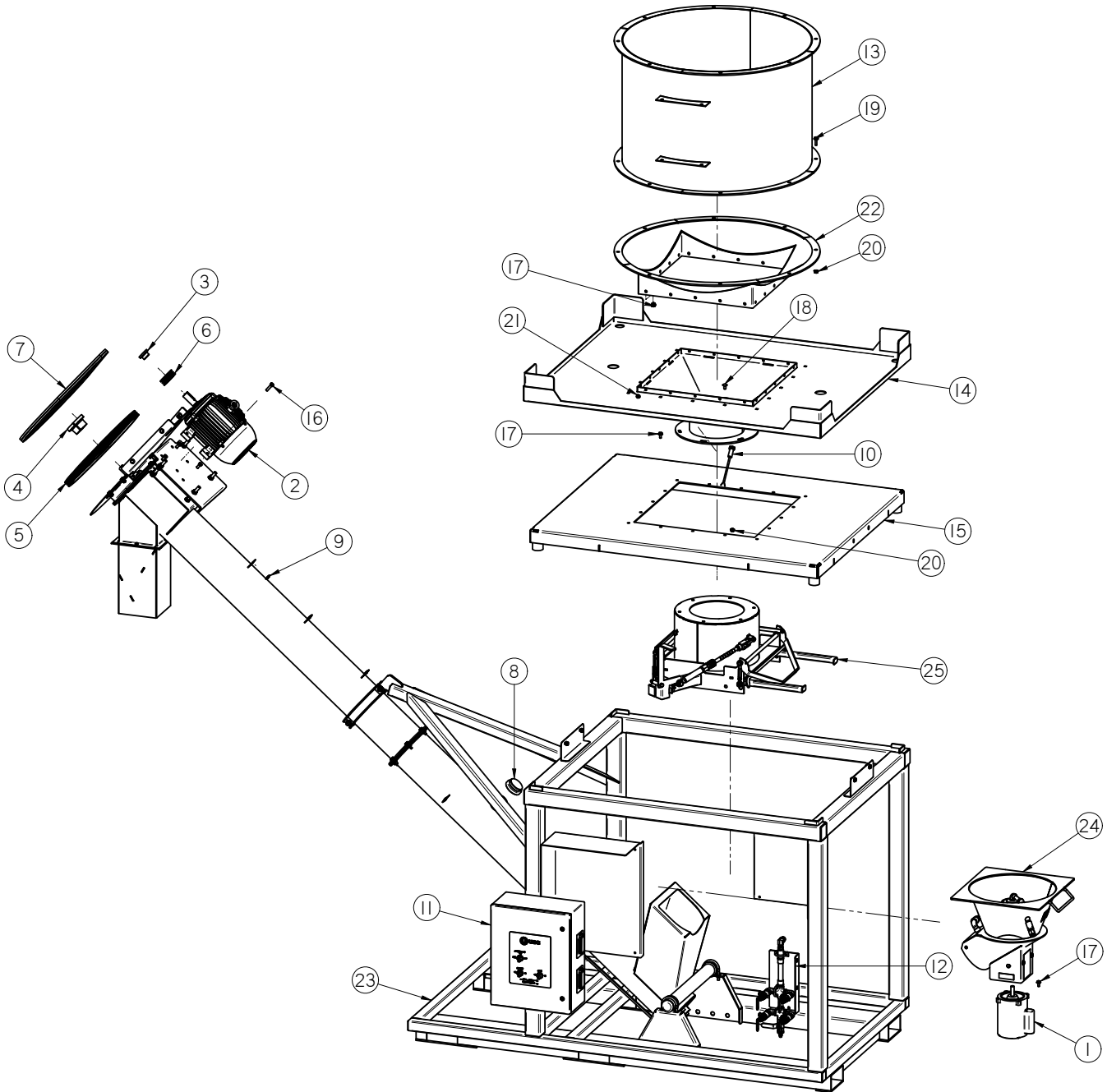

AT500H TREATER

HOPPER TOP ASSEMBLY (13-01-0307)

Item #	Part #	Description	Qty
1	01-01-0104	MTR .33HP 1725RPM 56C 1PH TENV	1
2	01-01-0127	MTR 3HP 1750RPM 184T TEFC 1PH	1
3	01-08-0029	Bushing JA 1.125	1
4	01-08-0037	BUSHING SK 1.00	1
5	01-08-0070	SHV 3V19.00X2 SK	1
6	01-08-0071	SHV 3V3.0X2 JA	1
7	01-08-0072	BELT 3VX670	2
8	02-14-0022	FTTG END CAP 2IN NPT 125PSI ZP/GALV	1
9	03-09-0015	GRMT RBBR .500ID X 1.00OD X .750KO	5
10	03-10-0051	SENS PROX 24-240 AC AB 875CPG8N18A2	1
11	03-12-0378	AT500H CONTROL PANEL	1
12	04-03-0157	ASSY STTC MXR & VLVS LPX TRTR	1
13	05-03-0238	WDMT HOPP EXT AT 500	1
14	05-07-0747	WDMT HOPP SCALE GUIDE AT500 LIW	1
15	05-08-0399	WDMT SUB 5 X 4 LIW SCL	1
16	06-01-0018	BOLT .375-16 X 1.50 ZP GR5	4
17	06-01-0124	BOLT, FLG .375-16 UNC ZP GRADE 5; 3/4" LG	34
18	06-01-0153	BOLT CRG .375-16X.750 ZP SHORT NECK	18
19	06-01-0189	BOLT, FLG .375-16 UNC ZP GRADE 5; 1-1/4" LG	8
20	06-03-0014	NUT LOCK FLG .375-16 ZP GR5	33
21	06-03-0019	NUT LOCK FLG .3125-18 ZP GR5	20
22	10382A	SMW ADAPTER	1
23	13-11-0032	ASSY BASE AT500 LIW 144IN AUGER	1
24	18-01-0282	ASSY ATMZR AT500 LIW CS	1
25	18-01-0287	ASSY ADJ CHMBR AT500	1

AT500H TREATER

AT500H BASE ASSEMBLY (13-11-0032)

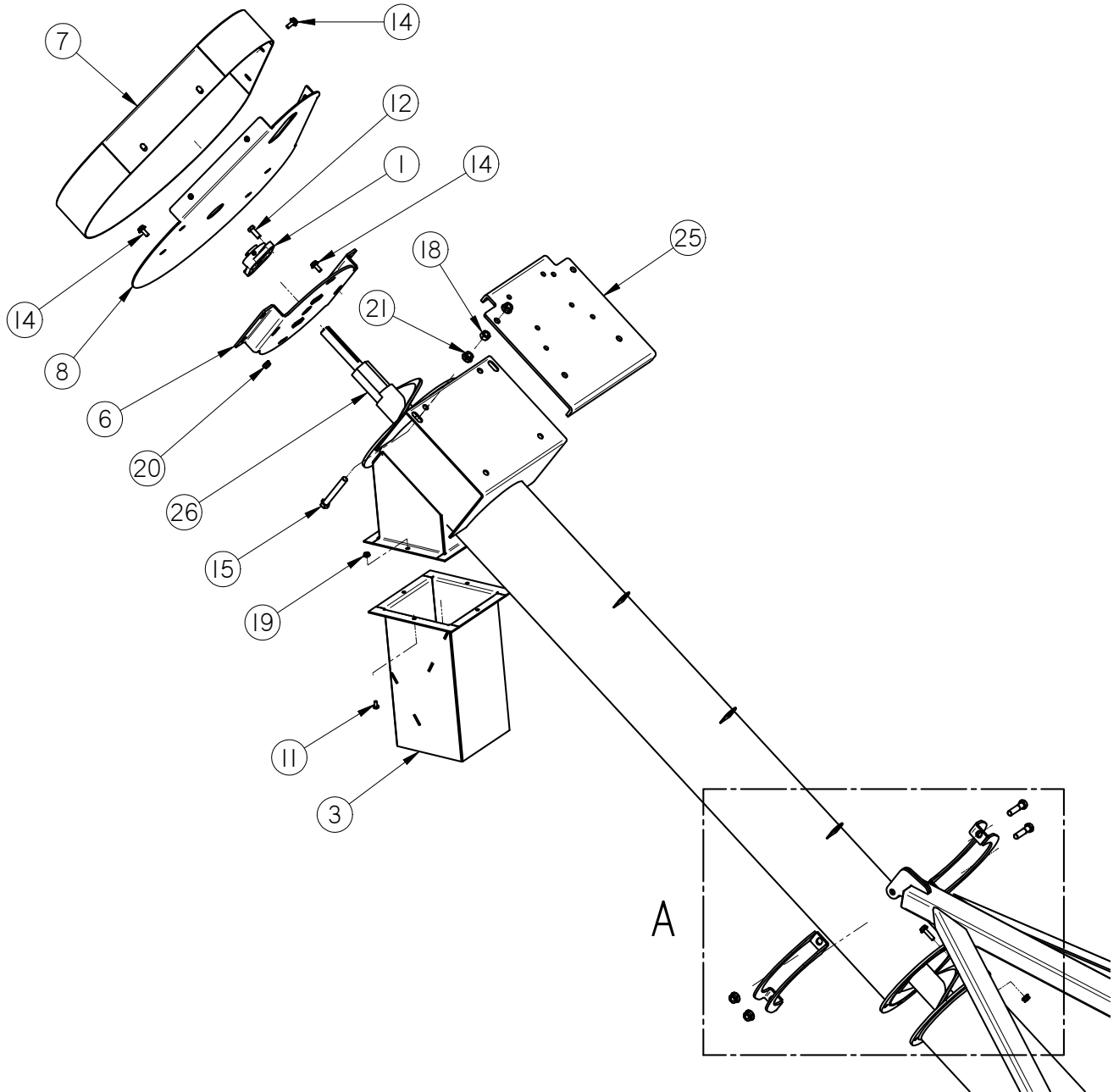

AT500H TREATER

AT500H BASE ASSEMBLY (13-11-0032)

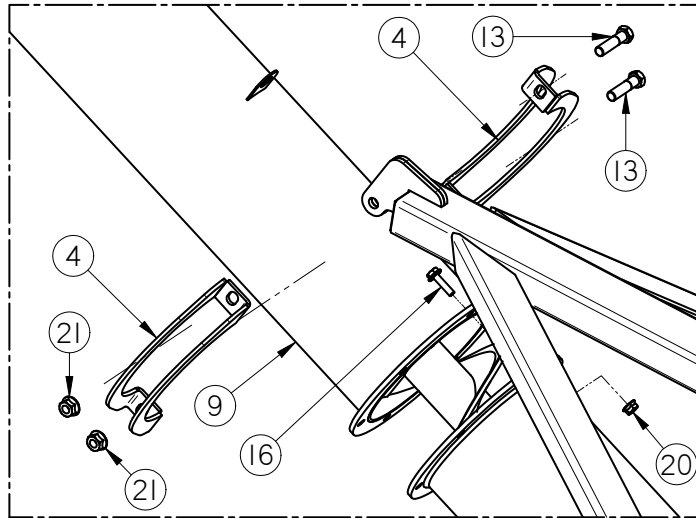

DETAIL A

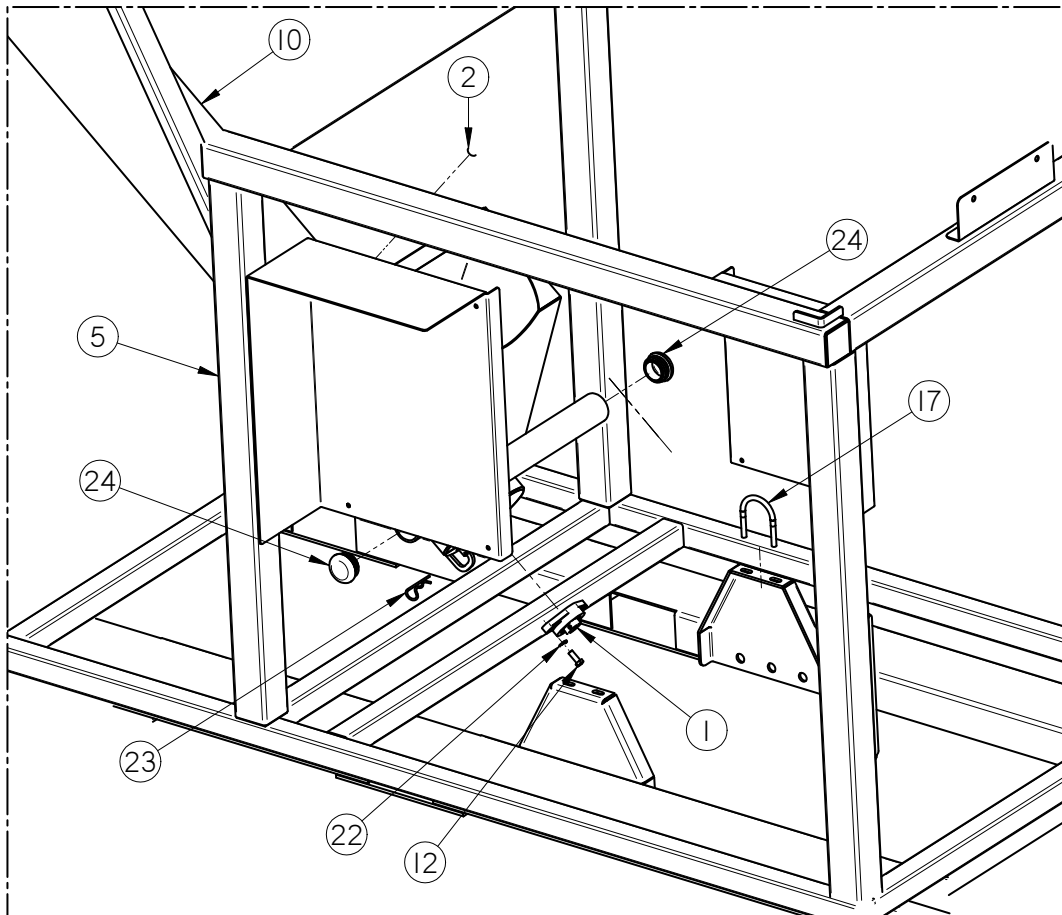

AT500H TREATER

AT500H BASE ASSEMBLY (13-11-0032)

Item #	Part #	Description	Qty
1	01-03-0003	BRG FLG MNT 1.000ID 2BOLT	2
2	02-14-0001	FTTG PLUG SQHD .500 NPT SS	1
3	05-03-0230	WDMT SEED LADDER AT500	1
4	05-03-1262	WDMT 14IN TUBE CLAMP	2
5	05-03-1485	WDMT BASE FR AT500 LIW 144IN AUGER	1
6	05-04-0050	WDMT AUGER DSCHG PLATE AT 500	1
7	05-06-0061	WDMT GRD CVR AT500	1
8	05-06-0062	WDMT GRD BACK AT500	1
9	05-08-0223	WDMT UPPER AUGER TUBE AT500	1
10	05-08-0398	WDMT LOWER AUGER TUBE AT500	1
11	06-01-0004	BOLT, .250-20 X .500 UNC ZP GRADE 5	4
12	06-01-0016	BOLT .375-16 X 1.00 ZP GR5	4
13	06-01-0027	BOLT .500-13 X 2.00 ZP GR5	2
14	06-01-0124	BOLT, FLG .375-16 UNC ZP GRADE 5; 3/4" LG	12
15	06-01-0157	BOLT, .500-13 X 4" UNC ZP GRADE 5	4
16	06-01-0189	BOLT, FLG .375-16 UNC ZP GRADE 5; 1-1/4" LG	6
17	06-01-0287	BOLT U .375-16 X 2.50 X 3.125 ZP	2
18	06-02-0004	NUT FULL .500-13 ZP GR5	4
19	06-03-0013	NUT,LOCK, FLG .250-20 ZP SERRATED	4
20	06-03-0014	NUT LOCK FLG .375-16 ZP GR5	14
21	06-03-0015	NUT LOCK FLG .500-13 ZP GR5	10
22	06-04-0003	WSHR LOCK SPLT .375 ZP	2
23	06-09-0039	PIN CLIP HITCH 2.625 #11 1/8 IN ZP	1
24	06-10-0056	PLUG TBG RD RIB POLY 2.38 X .156W	2
25	100ED5	PLT MTR MNT AT 500 ADAPTER	1
26	11-05-0013	ASSY POLY CUP FLIGHT W SHAFT 142LG	1

USC LIMITED WARRANTY**SECTION
K**

USC, LLC, (Manufacturer) warrants its seed treating equipment as follows:

1. **Limited Warranty:** Manufacturer warrants that the Products sold hereunder will be free from defects in material and workmanship for a period of 18 months from date of shipment. If the Products do not conform to this Limited Warranty during the warranty period, Buyer shall notify Manufacturer in writing of the claimed defects and demonstrate to Manufacturer satisfaction that said defects are covered by this Limited Warranty. If the defects are properly reported to Manufacturer within the warranty period, and the defects are of such type and nature as to be covered by this warranty, Manufacturer shall, at its expense, furnish replacement Products or, at Manufacturer's option, replacement parts for the defective products. Shipping and installation of the replacement Products or replacement parts shall be at the Buyer's expense.

2. **Other Limits:** THE FOREGOING IS IN LIEU OF ALL OTHER WARRANTIES, EXPRESSED OR IMPLIED, INCLUDING BUT NOT LIMITED TO THE IMPLIED WARRANTIES OF MERCHANTABILITY AND FITNESS FOR A PARTICULAR PURPOSE. Manufacturer does not warrant against damages or defects arising from improper installation (where installation is by persons other than Manufacturer), against defects in products or components not manufactured by Manufacturer, or against damages resulting from such non-Manufacturer made products or components. Manufacturer passes on to the Buyer the warranty it received (if any) from the maker of such non-Manufacturer made products or components. This warranty also does not apply to Products upon which repairs and/or modifications have been effected or attempted by persons other than pursuant to written authorization by Manufacturer. Manufacturer does not warrant against casualties or damages resulting from misuse and/or abuse of product(s), acts of nature, effects of weather, including effects of weather due to outside storage, accidents, or damages incurred during transportation by common carrier.

3. **Exclusive Obligation:** THIS WARRANTY IS EXCLUSIVE. The sole and exclusive obligation of Manufacturer shall be to repair or replace the defective Products in the manner and for the period provided above. Manufacturer shall not have any other obligation with respect to the Products or any part thereof, whether based on contract, tort, strict liability or otherwise. Under no circumstances, whether based on this Limited Warranty or otherwise, shall Manufacturer be liable for incidental, special, or consequential damages.

4. **Other Statements:** Manufacturer's employees or representatives' oral or other written statements do not constitute warranties, shall not be relied upon by Buyer, and are not a part of the contract for sale or this limited warranty.

5. **Return Policy:** Approval is required prior to returning goods to USC, LLC. A restocking fee will apply.

6. **Entire Obligation:** This Limited Warranty states the entire obligation of Manufacturer with respect to the Products. If any part of this Limited Warranty is determined to be void or illegal, the remainder shall remain in full force and effect.



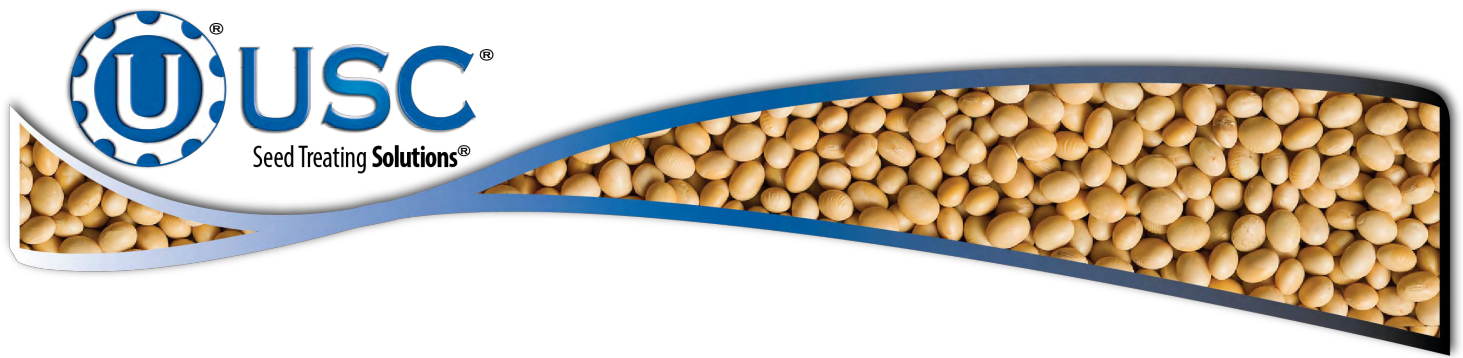

USC, LLC

2320 124th road

Sabetha, KS 66534

PHONE: (785) 431-7900

FAX: (785) 431-7950

EMAIL: sales-team@uscllc.com

WEB: www.uscllc.com

