

SEED CONDITIONER

Operators Manual

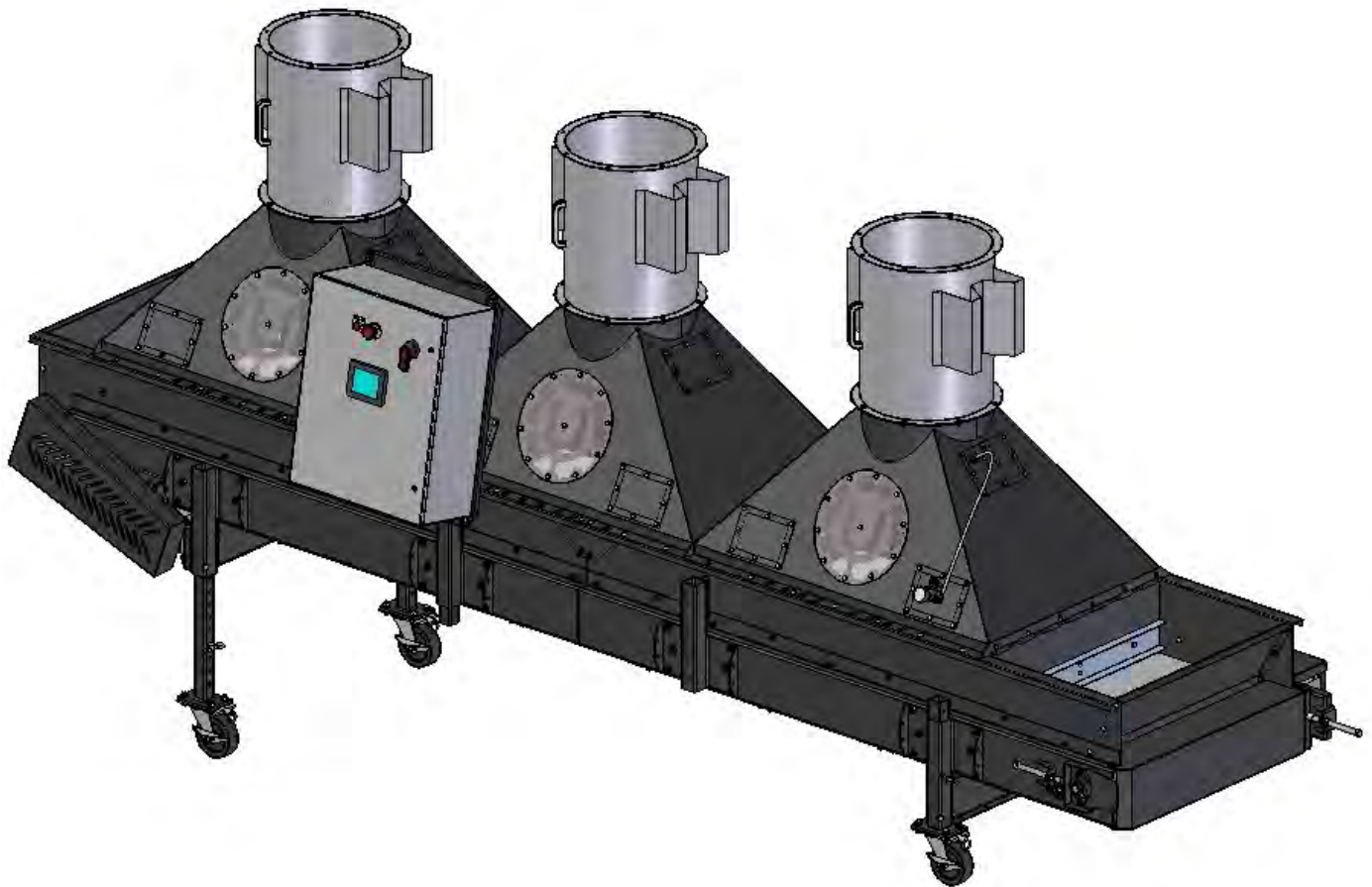

Software Release: v1.0.0

Document: TD-09-06-1010

Revision: B



INTRODUCTION

Thank you for choosing USC, LLC for your equipment needs. We appreciate your business and will work diligently to ensure that you are satisfied with your choice.

OVERVIEW

The purpose of this manual is to provide you with the basic information needed to operate and maintain the Seed Conditioner. It does not hold USC, LLC liable for any accidents or injuries that may occur.

OPERATOR RESPONSIBILITIES

As the purchaser/owner/operator of this equipment and control system, you have an obligation to install, operate, and maintain the equipment in a manner that minimizes the exposure of people in your care to any potential hazards inherent in using this equipment. It is critical that the owner of this equipment:

- Has a clear and documented understanding of the process this machine is being used in and of any resulting hazards or special requirements arising from this specific application.
- Allow only properly trained and instructed personnel to install, operate or service this equipment.
- Maintain a comprehensive safety program involving all who work with this machine and other associated process equipment.
- Establish clear areas of staff responsibility (e.g. operation, setup, sanitation, maintenance, and repairs).
- Provide all personnel with necessary safety equipment.
- Periodically inspect the equipment to insure that the doors, covers, guards, and safety devices are in place and functioning, that all safety instructions and warning labels are intact and legible, and that the equipment is in good working order.
- In addition to the operating instructions, observe and enforce the applicable legal and other binding regulations, national and local codes.

As the person with the most to gain or lose from working safely, it is important that you work responsibly and stay alert. By following a few simple rules, you can prevent an accident that could injure or kill you or a co-worker.

SEED CONDITIONER

- Do not operate, clean, or service this equipment until you have read and understood the contents of this manual. If you do not understand the information in this manual, bring it to the attention of your supervisor, or call USC at (785) 431-7900 for assistance.
- Any operator who is known or suspected to be under the influence of alcohol or drugs should not be allowed to operate the equipment.
- Understand and follow the safety practices required by your employer and this manual.
- **PAY ATTENTION** to what you and other personnel are doing and how these activities may affect your safety.
- **Failure to follow these instructions may result in serious personal injury or death.**

RECEIVING YOUR EQUIPMENT

As soon as the equipment is received, it should be carefully inspected to make certain that it has sustained no damage during shipment and that all items listed on the packing list are accounted for. If there is any damage or shortages, the purchaser must immediately notify USC, LLC. Ownership passes to purchaser when the unit leaves the USC, LLC. premises. The purchaser is responsible for unloading and mounting all components of the equipment.

Document the serial number of the machine for future reference. The serial number is located on the side of the unit near the chain drive guard.



*Serial
Number*

SERIAL NUMBER: _____

TABLE OF CONTENTS

<u>Section</u>	<u>Contents</u>	<u>Page #</u>
Section A	Safety Instructions.....	5
Section B	Installation	14
Section C	Mechanical Operation.....	17
	Seed Conditioner Overview.....	17
Section D	Electrical Operation	18
	Main Screen	20
	H-O-A Screen.....	22
	Utilities Screen	24
	Alarm and E-Stop Screen	26
Section E	Troubleshooting.....	28
Section F	Maintenance	29
	Wire Mesh Belt Drive Tension	31
	Wire Mesh Belt Alignment & Tracking	32
Section G	Storage.....	35
Section H	Mechanical Drawings	37
Section I	Limited Warranty.....	59

SAFETY INSTRUCTIONS

SECTION A

Every year accidents in the work place maim, kill and injure people. Although it may be impossible to prevent all accidents, with the right combination of training, operating practices, safety devices and operator vigilance, the number of accidents can be significantly reduced. The purpose of this section is to educate equipment users about hazards, unsafe practices and recommended hazard avoidance techniques.

SAFETY WORDS AND SYMBOLS

It is very important that operators and maintenance personnel understand the words and symbols that are used to communicate safety information. Safety words, their meaning and format, have been standardized for U.S. manufacturers and published by the American National Standards Institute (ANSI). The European Community (E.C.) has adopted a different format based on the International Standards Organization (I.S.O.) and applicable machinery directives. Both formats are presented below. Graphic symbols are not standardized but most manufacturers will use some variation of the ones seen in this manual.



Indicates an imminently hazardous situation which, if not avoided, **will** result in death or serious injury.



Indicates a potentially hazardous situation which, if not avoided, **could** result in death or serious injury.



Indicates a potentially hazardous situation which, if not avoided, **may** result in minor or moderate injury and/or property damage.



Provides additional information that the operator needs to be aware of to avoid a potentially hazardous situation.



Mandatory Lockout Power Symbol. Disconnect, lockout and tagout electrical and other energy sources before inspecting, cleaning or performing maintenance on this panel.



International Safety Alert Symbol. The exclamation point (!) surrounded by a yellow triangle indicates that an injury hazard exists. However, it does not indicate the seriousness of potential injury. The exclamation point (!) is also used with the DANGER, WARNING and CAUTION symbols so the potential injury is indicated.



Electrocution Hazard Symbol. This symbol indicates that an electrocution hazard exists. Serious injury or death could result from contacting high voltage.



International Electrocution Hazard. This symbol indicates that an electrocution hazard exists. Serious injury or death could result from contacting high voltage.



Mandatory Read Manual Action Symbol. (I.S.O. format) This symbol instructs personnel to read the Operators Manual before servicing or operating the equipment.



Mandatory Read Manual Action Symbol. This symbol instructs personnel to read the Operators Manual before servicing or operating the equipment.

NOTICE

Notice is used to notify people of important installation, operation or maintenance information which is not hazard related.

LOCKOUT / TAGOUT PROCEDURES

Lockout/Tagout is the placement of a lock/tag on an energy isolating device in accordance with an established procedure. When taking equipment out of service to perform maintenance or repair work, always follow the lockout/tagout procedures as outlined in ANSI Z344.1 and/or OSHA Standard 1910.147. This standard “requires employers to establish a program and utilize procedures for affixing appropriate lockout devices or tagout devices to energy isolating devices and to otherwise disable machines or equipment to prevent unexpected energizing, start-up, or release of stored energy in order to prevent injury to employees.”

EMERGENCY STOP



There is an Emergency Stop push button on the Seed Conditioner located on the Main Control Panel. Actuators of emergency stop shall be colored RED. The background immediately around the device actuator shall be colored YELLOW. The actuator pushbutton operated device shall be of the palm or mushroom head type.

HAZARD REVIEW

Electrocution Hazard



Electrocution accidents are most likely to occur during maintenance of the electrical system or when working on or near exposed high voltage wiring. This hazard does not exist when the electrical power has been disconnected, properly locked, and tagged out.

Automatic Start Hazard



This equipment may be controlled by an automated system and may start without warning. Failure to properly disconnect, lockout, and tagout all energy sources of remotely controlled equipment creates a very hazardous situation and could cause injury or even death. PLEASE STAY CLEAR AND BE ALERT.

SEED CONDITIONER

YOU are responsible for the **SAFE** operation and maintenance of your USC, LLC equipment . **YOU** must ensure that you and anyone else who is going to operate, maintain or work around the equipment be familiar with the operating and maintenance procedures and related **SAFETY** information contained in this manual. This manual will take you step-by-step through your working day and alert you to good safety practices that should be adhered to while operating the equipment

Remember, **YOU** are the key to safety. Good safety practices not only protect you, but also the people around you. Make these practices a working part of your safety program. Be certain that **EVERYONE** operating this equipment is familiar with the recommended operating and maintenance procedures and follows all the safety precautions. Most accidents can be prevented. Do not risk injury or death by ignoring good safety practices.

- Equipment owners must give operating instructions to operators or employees before allowing them to operate the machine, and at least annually thereafter per OSHA (Occupational Safety and Health Administration) regulation 1928.57.
- The most important safety device on this equipment is a **SAFE** operator. It is the operator's responsibility to read and understand **ALL** Safety and Operating instructions in the manual and to follow them. All accidents can be avoided.
- A person who has not read and understood all operating and safety instructions is not qualified to operate the machine. An untrained operator exposes himself and bystanders to possible serious injury or death.
- Do not modify the equipment in any way. Unauthorized modification may impair the function and/or safety and could affect the life of the equipment.
- Think SAFETY! Work SAFELY!

GENERAL SAFETY

1. Read and understand the operator's manual and all safety labels before operating, maintaining, adjusting or unplugging the equipment .
2. Only trained persons shall operate the equipment . An untrained operator is not qualified to operate the machine.
3. Have a first-aid kit available for use should the need arise, and know how to use it.



SEED CONDITIONER

4. Provide a fire extinguisher for use in case of an accident. Store in a highly visible place.
5. Do not allow children, spectators or bystanders within hazard area of machine.
6. Wear appropriate protective gear. This includes but is not limited to:
 - A hard hat
 - Protective shoes with slip resistant soles
 - Protective goggles
 - Heavy gloves
 - Hearing protection
 - Respirator or filter mask
7. Place all controls in neutral or off, stop motor, and wait for all moving parts to stop. Then disable power source before servicing, adjusting, repairing, or unplugging.
8. Review safety related items annually with all personnel who will be operating or maintaining the equipment.

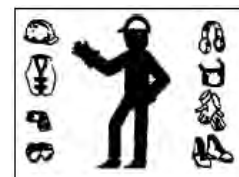

OPERATING SAFETY:

1. Read and understand the operator's manual and all safety labels before using.
2. Disconnect and disable electrical supply completely and wait for all moving parts to stop before servicing, adjusting, repairing or unplugging.
3. Clear the area of bystanders, especially children, before starting.
4. Be familiar with the machine hazard area. If anyone enters hazard area, shut down machine immediately. Clear the area before restarting.
5. Keep hands, feet, hair and clothing away from all moving and/or rotating parts.
6. Stay away from overhead obstructions and power lines during operation and transporting. Electrocutation can occur without direct contact.
7. Do not operate machine when any guards are removed.
8. Inspect welds and repair if needed.

SEED CONDITIONER

PLACEMENT SAFETY

1. Move only with the appropriate equipment
2. Stay away from overhead power lines when moving equipment. Electrocutation can occur without direct contact.
3. Be familiar with machine hazard area. If anyone enters hazard areas, shut down machine immediately. Clear the area before restarting.
4. Operate the equipment on level ground free of debris. Anchor the equipment to prevent tipping or upending.



Before placement of the equipment, be sure that ground is reasonably level. The equipment may topple or work improperly if the ground is too uneven, damaging the equipment and/or causing personal injury.

MAINTENANCE SAFETY

1. Review the operator's manual and all safety items before working with, maintaining or operating the equipment.
2. Place all controls in neutral or off, stop motors, disable power source, and wait for all moving parts to stop before servicing, adjusting, repairing or unplugging.
3. Follow good shop practices:
Keep service area clean and dry.
Be sure electrical outlets and tools are properly grounded.
Use adequate light for the job at hand.
4. Keep hands, feet, hair and clothing away from all moving and/or rotating parts.
5. Clear the area of bystanders, especially children, when carrying out any maintenance and repairs or making any adjustments.
6. Before resuming work, install and secure all guards when maintenance work is completed.
7. Keep safety labels clean. Replace any sign that is damaged or not clearly visible.



SEED CONDITIONER

SAFETY LABELS

1. Keep safety labels clean and legible at all times.
2. Replace safety labels that are missing or have become illegible.
3. Replaced parts that displayed a safety label should also display the current label.
4. Replacement safety labels are available. Contact USC at (785) 431-7900 .

How to Install Safety Labels:

- Be sure that the installation area is clean and dry.
- Be sure temperature is above 50°F (10°C).
- Decide on the exact position before you remove the backing paper.
- Remove the smallest portion of the split backing paper.
- Align the sign over the specified area and carefully press the small portion with the exposed sticky backing in place.
- Slowly peel back the remaining paper and carefully smooth the remaining portion of the sign in place.
- Small air pockets can be pierced with a pin and smoothed out using the piece of sign backing paper.



Located on the USC equipment you will find safety labels. Always be sure to read and follow all directions on the labels.



Guards provided with USC equipment are to remain in place during operation.

SEED CONDITIONER

Think **SAFETY!** Work **SAFELY!**

REMEMBER—If safety labels have been damaged, removed, become illegible, or parts replaced without safety labels, new labels must be applied. New safety labels are available from USC at (785) 431-7900.



Part # 09-02-0001



Part # 09-02-0010



SEED CONDITIONER



Part # 09-02-0011



Part # 09-02-0002



Part # 09-02-0009



SECTION
B**INSTALLATION**

HIGH VOLTAGE ~ Always disconnect the power source before working on or near the control panel or lead wires.



HIGH VOLTAGE ~ Use insulated tools when making adjustments while the controls are under power.

NOTICE

Permanent installation may require additional electrical cords, chemical tubing, and air lines, since each installation is unique.

SEED CONDITIONER SET-UP

The following steps outline the initial set-up of your USC Seed Conditioner :

1. Clear the area of bystanders, especially small children, before moving.
2. Be sure there is enough clearance from overhead obstructions and power lines or other equipment to move the machine into its working position.
3. Using a forklift, place the Seed Conditioner in the desired position on a level surface.

NOTICE

USC highly recommends that the Seed Conditioner be set up inside a building or any covered structure to protect the machine from weathering.

4. Inspect Seed Conditioner thoroughly for screws, bolts, fittings, etc. which may have come loose during shipping.
5. The Seed Conditioner should be placed on level ground close to the seed treater.
6. Setup the Seed Conditioner control panel assembly on the left or right lower frame cross member.
7. Have a certified electrician provide 230V or 460V power to the seed conditioner. Provide convenient shutdown switches, comply with local electrical codes and ensure that the system is properly grounded and bonded. All USC control panels must be connected adhering to the same electrical requirements as specified in the main control panel on the power requirement tag (right), or the electrical schematic shipped with the piece of equipment. This will power the USC Seed Conditioner.

SEED CONDITIONER

SEED CONDITIONER SET-UP

NOTICE

Flexible conduit is recommended for main power supply.

Incoming power connected to these terminals in the Seed Conditioner Control Panel

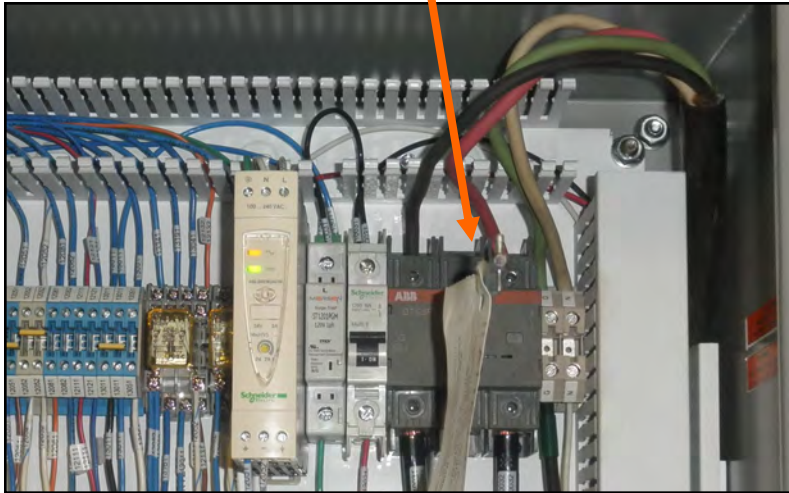

 Seed Treating Solutions™			
Mfg. By: USC, LLC Max voltage: 230V, 1PH, 60 HZ Total FLA: 52 Largest Motor FLA: 12 Schematic number: 03-12-0380A Enclosure rating: UL type 1 Short Circuit Current Rating: 5ka RMS Sym, 600V Max			
<p style="text-align: center;">WARNING</p> To maintain over current, short-circuit and ground fault protection, the manufacturer's instruction for selection of overload and short circuit protection must be followed to reduce the risk of fire or electrical shock.			
<p style="text-align: center;">WARNING</p> If an overload or a fault current interruption occurs, circuits must be checked to determine the cause of the interruption. If a fault condition exists, the current-carrying components should be examined and replaced if damaged, and the integral current sensors must be replaced to reduce the risk of fire or electrical shock.			
SEED CONDITIONER CONTROL PANEL See schematic number: 03-12-0380A for interconnections.			
Replacement Fuse Chart			
Fuse	Line	Size	Type
FU1006	1006, 1008	20A	CLASS CC 600V
FU1010	1010, 1012	20A	CLASS CC 600V
FU1101	1101, 1103	20A	CLASS CC 600V
FU1105	1105, 1107	20A	CLASS CC 600V
<p style="text-align: center;">!! WARNING !!</p> 230Volts/ 1Phase/60 Hertz supply only. L1 to Neutral voltage must not exceed 120 Volts!!			

- It is required that the air supply have an in-line customer supplied air dryer to protect the air system from contamination. Supply approximately 100 - 110 pounds of air pressure from the dryer to the port on the air actuated 3-way valve located on the pump stand frame behind the electric control panel.

Air Supplied Here

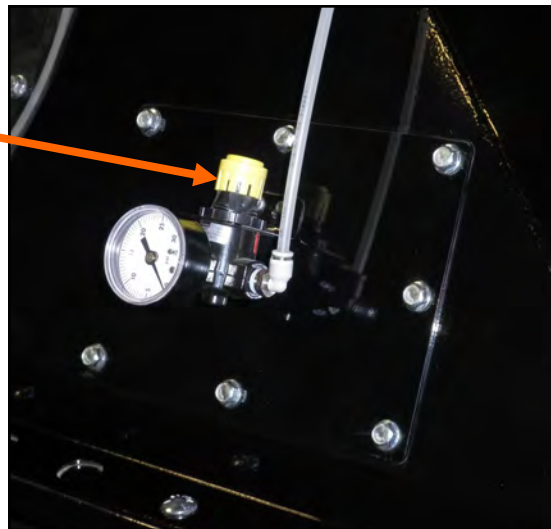

SEED CONDITIONER

SEED CONDITIONER SET-UP

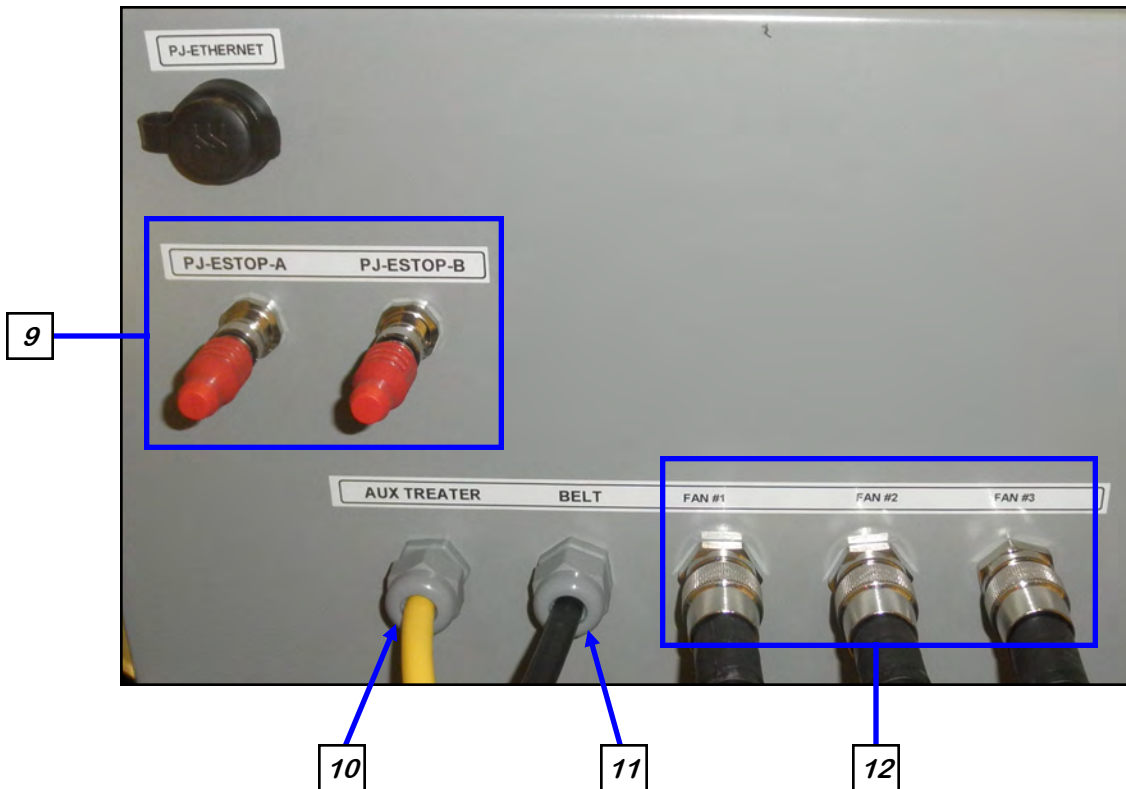

9. Connect the red cable to the PJESTOPA on the treater control panel or automated main control panel and then to the PJESTOPB on the Seed Conditioner control panel. This cable must run from an A connection to a B connection (never A to A or B to B).
10. Connect this cable to an auxiliary port on the bottom of the treater control panel.
11. Connect this cable to the belt drive motor.
12. Connect the FAN #1 cable to the fan on the inlet end of the conditioner, the FAN #2 cable to the middle fan and FAN #3 to the fan on the discharge end

MECHANICAL OPERATION

SEED CONDITIONER OVERVIEW

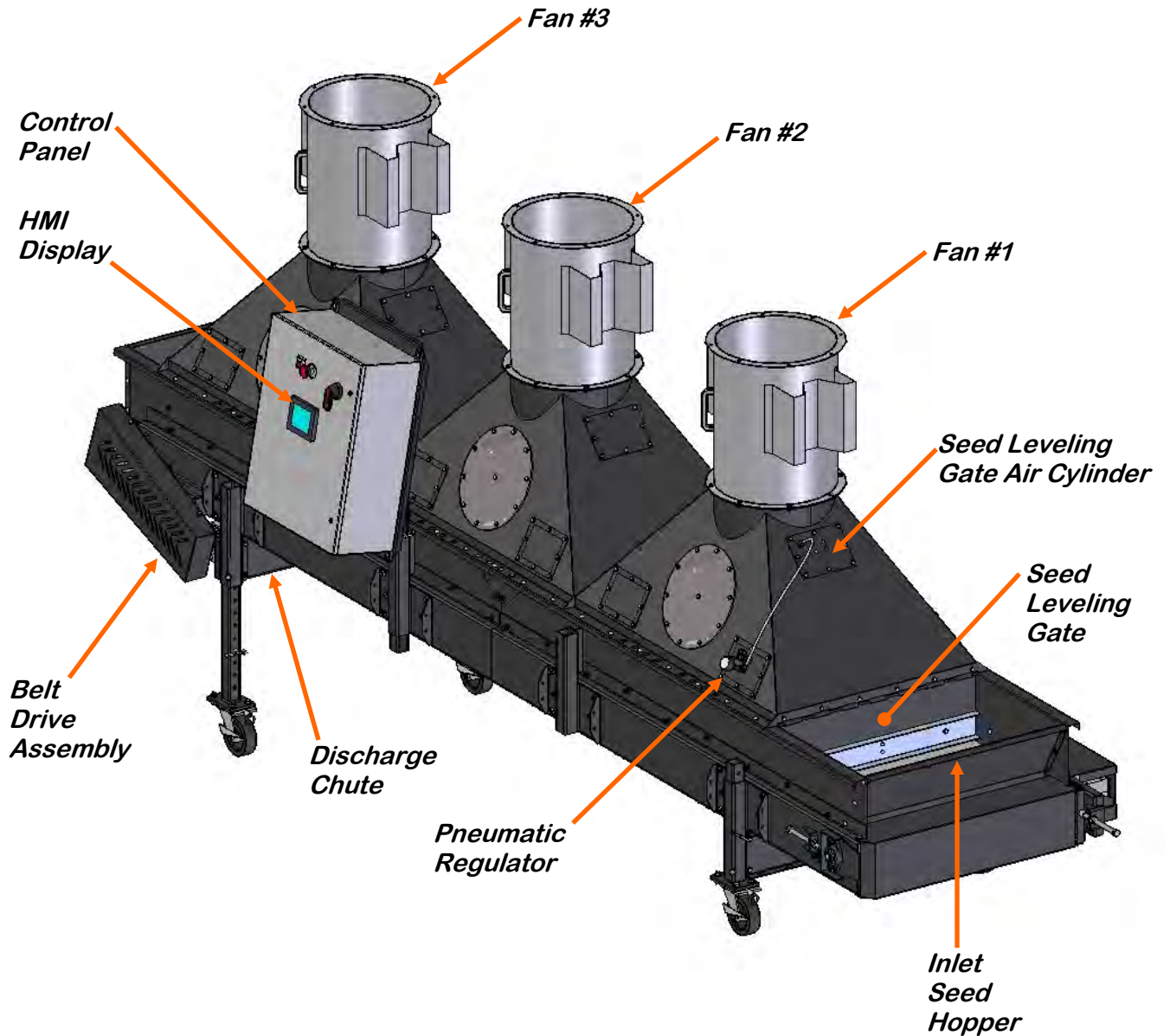

SECTION
D**ELECTRICAL OPERATION**

HIGH VOLTAGE ~ Always disconnect the power source before working on or near the control panel or lead wires.



HIGH VOLTAGE ~ Use insulated tools when making adjustments while the controls are under power.



AUTHORIZED PERSONNEL only shall work on the control panel. Never allow anyone who has not read and familiarized themselves with the owner's manual to open or work on the control panel.

This section provides a general overview and description of the operator controls for the Seed Conditioner.



USC recommends the use of a surge protection device with a minimum rating of 400 Joules for all automated main control panels.

General Panel Descriptions

- The Seed Conditioner control panel is a 30 x 24 x10 inch enclosure that contains all of the electrical control components as well as the HMI (Human/Machine Interface) touch screen. The operator is able to control the entire system through the HMI.

SEED CONDITIONER

Seed Conditioner Panel

The following pages explain the function of the touch screen controls.

USC STARTUP SCREEN

This screen is the first screen the operator will see after the system receives power. After 30 seconds the system will automatically advance to the Main screen.



SEED CONDITIONER

MAIN SCREEN

This screen informs the operator of the status of all system motors and electrical devices and allows for control / adjustment of system operations.

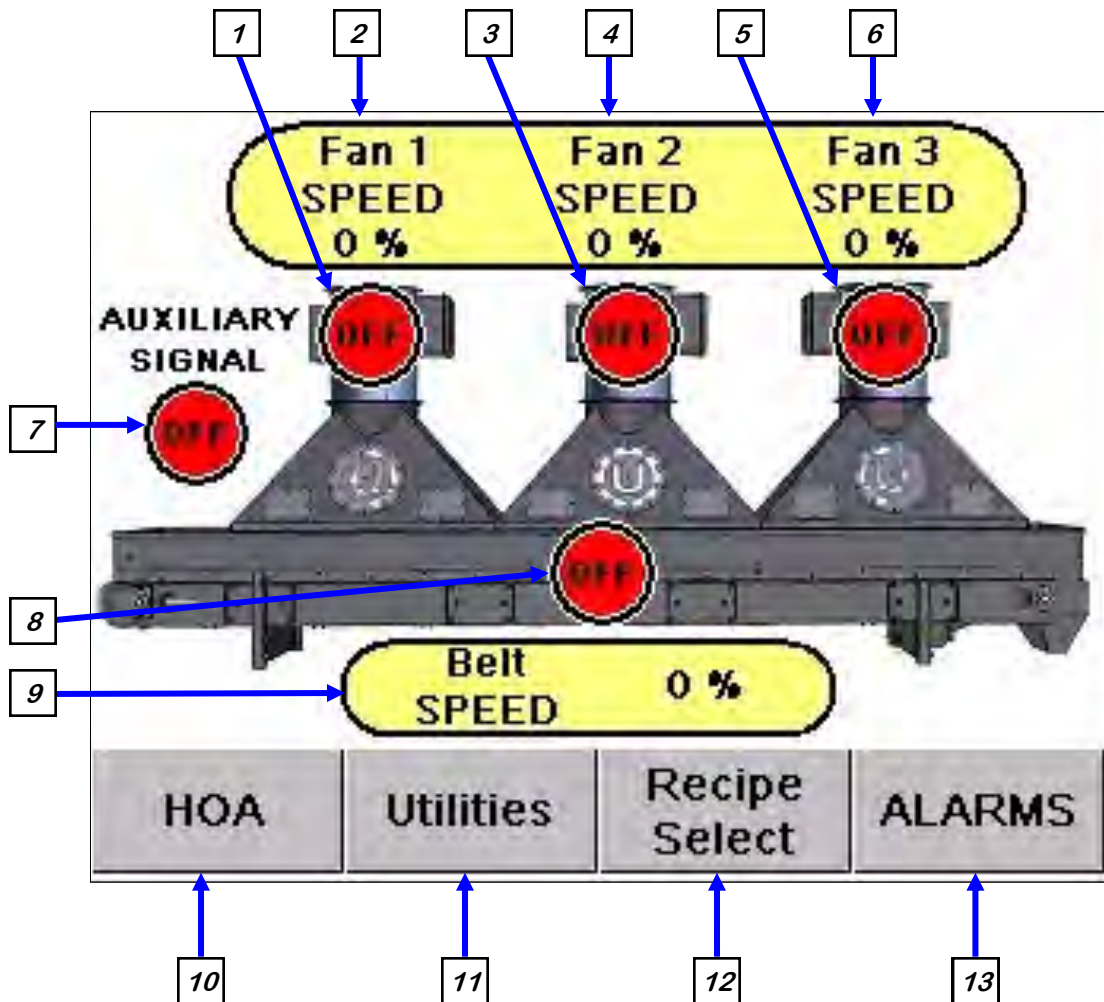

Main Screen Button Descriptions

1. FAN 1 MOTOR STATUS INDICATOR: Informs the operator if the fan motor is being told to be on (green) or off (red) and the text will indicate which mode it is currently in.

2. FAN 1 SPEED % INDICATOR: Displays what percentage of the full motor speed the fan is running.

3. FAN 2 MOTOR STATUS INDICATOR: Informs the operator if the fan motor is being told to be on (green) or off (red) and the text will indicate which mode it is currently in.

4. FAN 2 SPEED % INDICATOR: Displays what percentage of the full motor speed the fan is running.

5. FAN 3 MOTOR STATUS INDICATOR: Informs the operator if the fan motor is being told to be on (green) or off (red) and the text will indicate which mode it is currently in.

6. FAN 3 SPEED % INDICATOR: Displays what percentage of the full motor speed the fan is running.

7. AUXILIARY INPUT INDICATOR: Informs the operator if the Auxiliary Input signal is being received when in TREAT MODE.

8. BELT MOTOR STATUS INDICATOR: Informs the operator if the fan motor is being told to be on (green) or off (red) and the text will indicate which mode it is currently in.

9. BELT SPEED % INDICATOR: Displays what percentage of the full motor speed the fan is running.

10. H-O-A (Hand-Off-Auto) BUTTON: This button advances the operator to the H-O-A screen (page 22).

11. UTILITIES BUTTON: This button advances the operator to the UTILITIES screen (page 24).

12. RECIPE SELECT BUTTON: This button advances the operator to the Recipe Select List screen where the operator will select a saved recipe. Once selected all the recipe speed and time settings will be updated on the HOA and UTILITIES screens. If in the TREAT MODE choosing a recipe will set all devices to auto if they are not already in auto.

13. ALARM BUTTON: This button advances the operator to the ALARMS screen (page 26). If there is an active alarm this button will turn red.

SEED CONDITIONER

H-O-A (HAND-OFF-AUTO) SCREEN

Hand-Off-Auto controls are provided for most of the automated devices in the system, and are accessed on this screen.

WARNING



These H-O-A buttons force the selected component to be energized (HAND), de-energized (OFF), or automatically energized by the normal logic sequence (AUTO). The HAND function will cause the component to operate independent of whatever else the system is trying to do automatically. These functions should not normally be used if the automated sequencing is active. **Be sure to understand the impact of energizing or de-energizing a component with the HAND/OFF settings before using them. These commands are not a substitute for lockout/tagout procedures when working on or near this machine. Use proper lockout / tagout procedures to disable the equipment before servicing it.**

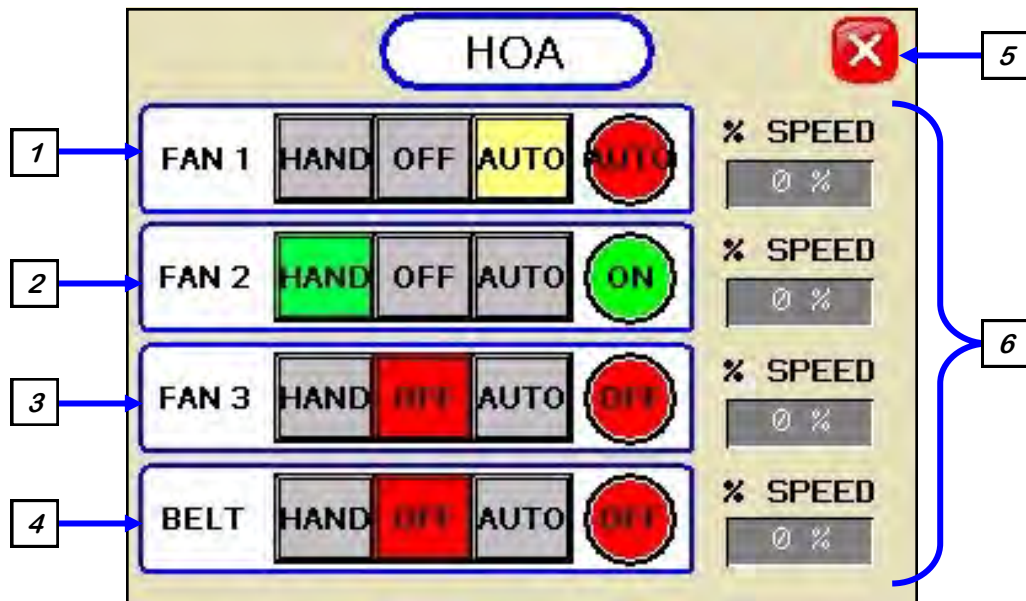

H-O-A Button Descriptions

1. FAN 1 CONTROL MODULE: This module controls the function of fan #1. The HAND button will place the fan in the manual mode of operation. The OFF button will turn the fan in the OFF mode of operation. The AUTO button will place the device in the automatic mode of operation. The motor will not operate in this function unless all other devices are in the AUTO mode and the TREAT MODE is selected in the Utilities screen.

2. FAN 2 CONTROL MODULE: This module controls the function of fan #2. The HAND button will place the fan in the manual mode of operation. The OFF button will turn the fan in the OFF mode of operation. The AUTO button will place the device in the automatic mode of operation. The motor will not operate in this function unless all other devices are in the AUTO mode and the TREAT MODE is selected in the Utilities screen.

3. FAN 3 CONTROL MODULE: This module controls the function of fan #3. The HAND button will place the fan in the manual mode of operation. The OFF button will turn the fan in the OFF mode of operation. The AUTO button will place the device in the automatic mode of operation. The motor will not operate in this function unless all other devices are in the AUTO mode and the TREAT MODE is selected in the Utilities screen.

4. BELT CONTROL MODULE: This module controls the function of the belt. The HAND button will place the belt in the manual mode of operation. The OFF button will turn the belt in the OFF mode of operation. The AUTO button will place the device in the automatic mode of operation. The motor will not operate in this function unless all other devices are in the AUTO mode and the TREAT MODE is selected in the Utilities screen.

5. SCREEN EXIT BUTTON: This button is used to exit back to the previous screen. Its functionality is the same throughout the HMI display.

6. MOTOR SPEED CONTROL MODULE: This module allows the operator to manually set the motor speeds whether running in HAND or AUTO modes.

SEED CONDITIONER

UTILITIES SCREEN

This screen allows the operator to set various system parameters and gives access to the RECIPE EDIT and INFO screens.

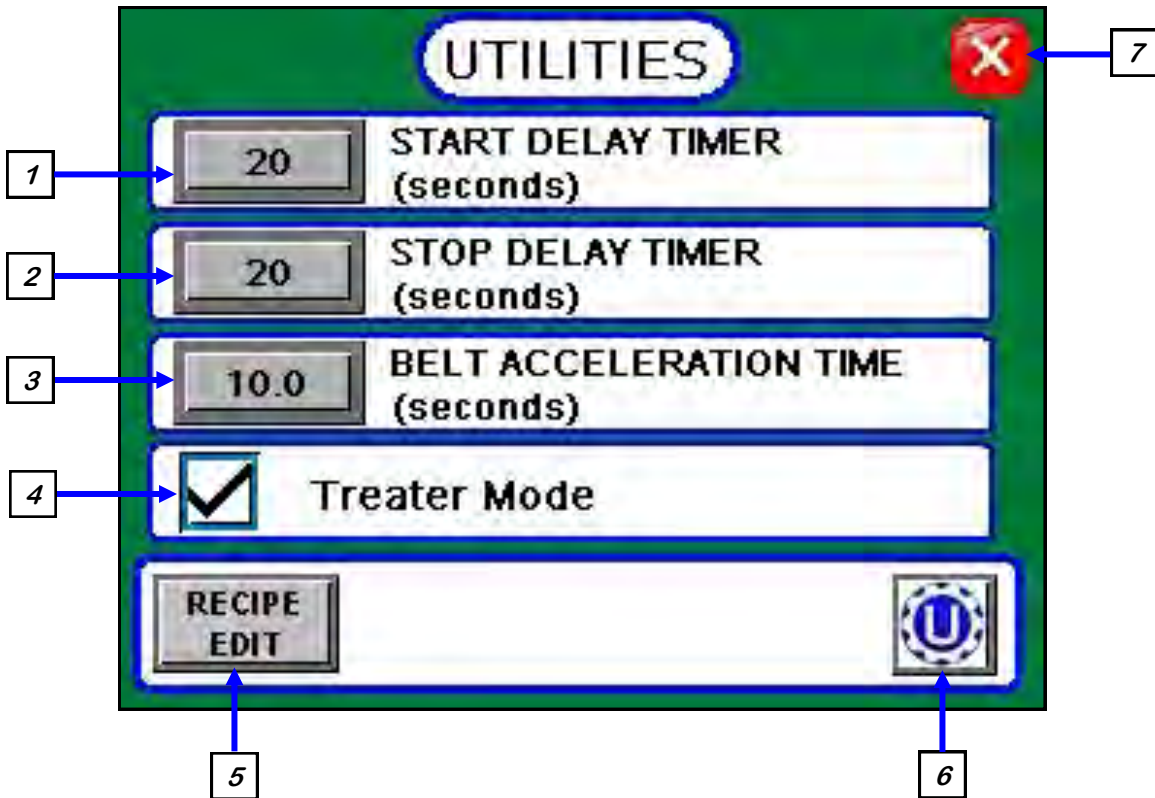

NOTICE

When buttons 1-3 are pressed, a numeric touch pad (right) will appear allowing the operator to enter in a number for that particular parameter.

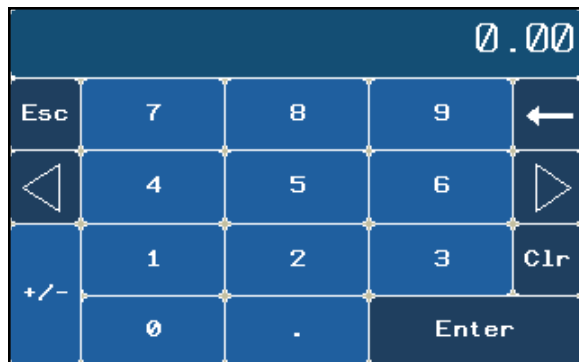

SEED CONDITIONER

1. START DELAY TIMER: Pressing this button allows the operator to adjust the time the system will wait to start when the Auxiliary Input is detected in AUTO mode.

2. STOP DELAY TIMER: Pressing this button allows the operator to adjust the time the system will wait to shutdown when the Auxiliary Input is no longer detected in AUTO mode.

3. BELT ACCELERATION TIME: Pressing this button allows the operator to adjust the time the belt will take to reach the speed setting.

4. TREAT MODE OPTION: Selecting this option sets the system to run with a treater in the Auto Mode. The system will automatically start up with TREAT MODE enabled when a signal is detected from the auxiliary port connected to the treater. When TREAT MODE is not selected the main screen will no longer display an auxiliary input and will show a START ALL or STOP ALL button. Pressing START ALL or STOP ALL will place Fans 1 through 3 and the Belt into Hand mode or Off mode depending on which button is pressed when the speed was last set on the HOA screen.

5. RECIPE EDIT BUTTON: Pressing this button will advance the operator to the Recipe Edit Selection screen. (bottom left) From here they will select a profile to edit on the Recipe Edit screen (bottom right). In the Recipe Info screen you may select the gray box you wish to edit. When a change is made the SAVE button will flash gray and green to notify the user a change has been made and not yet saved.

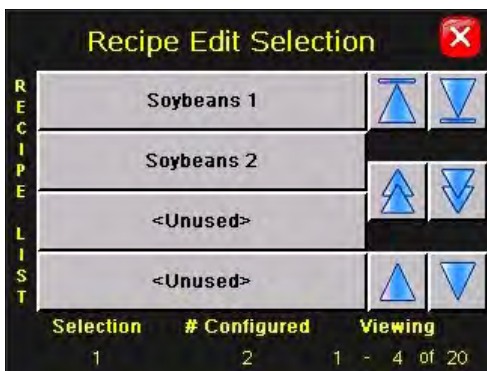
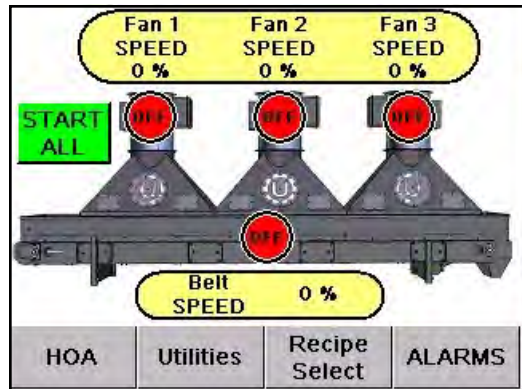
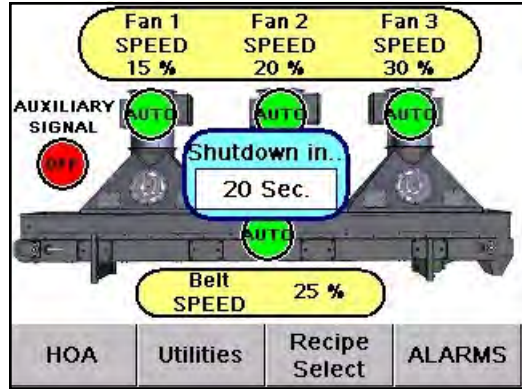

6. ABOUT USC: Pressing this button brings up a popup screen showing the operator what software release is installed.

7. SCREEN EXIT BUTTON: This button is used to exit back to the previous screen. Its functionality is the same throughout the HMI display.

SEED CONDITIONER

ALARMS SCREEN

This screen notifies the operator when an error has occurred with the system. It also defines the error so that it may be corrected. Once the problem has been fixed the operation may continue.



When an alarm is active, the indicator will be illuminated as shown above on Fan 3 and the alarm text will flash red and white. When the alarm is resolved the text will remain white and the light will remain lit until the operator presses it to clear the fault.



During an Emergency Stop, the ESTOP ACTIVE will be displayed on the screen and the system will be halted. To continue, the operator will need to pull all ESTOPS out and then press the RESET button on the front of the panel.

SEED CONDITIONER

If the system is in TREAT MODE, and a device has been set to a state other than AUTO, when the auxiliary input is received the warning below will be displayed. The system requires all devices to be in AUTO mode. By pressing the yellow SET ALL DEVICES TO AUTO button all devices will be set to AUTO and the startup timer will begin as long as the auxiliary input is still being received from the treater.



TROUBLESHOOTING

Below is a table describing the most frequent problems and solutions with the USC Seed Conditioner . For further assistance, contact the USC Service department at (785) 431-7900.

Problem	Possible Cause	Solution
When control panel power switch is turned on, panel has no power .	<ol style="list-style-type: none"> 1. If wired to a plug, plug not fully engaged in outlet. 2. Power source panel circuit breaker tripped. 	<ol style="list-style-type: none"> 1. Seat plug in outlet. 2. Re-set panel breaker.
A Fan or the belt will not start .	<ol style="list-style-type: none"> 1. Blown fuse. 2. Over current fault. 	<ol style="list-style-type: none"> 1. Replace fuse. 2. Power system down, wait ten seconds then turn power on to reset VFD's.
System has power but will not start .	<ol style="list-style-type: none"> 1. E-Stop switch engaged 2. Fans and belt in OFF mode on the HOA screen 	<ol style="list-style-type: none"> 1. Pull out E-Stop switch and press E-Stop reset button. 2. Place Fans and belt in the ON mode.
System not start when attached to a treater.	<ol style="list-style-type: none"> 1. Auxiliary cable not attached to treater. 2. Fans and belt are not in AUTO mode on the HOA screen. 	<ol style="list-style-type: none"> 1. Attach auxiliary cable to treater. 2. Place Fans and belt in the AUTO mode.
Excessive wire mesh belt noise.	<ol style="list-style-type: none"> 1. Belt is not aligned and tracking properly. 	<ol style="list-style-type: none"> 1. Align belt and adjust tracking (see page 31).
Wire mesh belt is slipping.	<ol style="list-style-type: none"> 1. Not enough tension on the belt. 	<ol style="list-style-type: none"> 1. Increase belt tension (see page 30).
Seed not leveling in bed.	<ol style="list-style-type: none"> 1. Not enough air cylinder pressure on seed leveling gate. 	<ol style="list-style-type: none"> 1. Increase the air pressure on the pneumatic regulator.

MAINTENANCE**SECTION
F**

Proper maintenance of the Seed Conditioner is critical for peak performance, reliability and accuracy of this system. The following is a guideline for the type of maintenance and servicing that should be performed on this unit. Your environment and uses may require additional maintenance and service beyond this list to assure a reliable and safe unit. The operator of this unit has ultimate responsibility to identify areas of concern and rectify them before they become a hazard or safety issue. There is no substitute for a trained, alert operator.



Do not put this unit into operation with any questionably maintained parts. Poor performance or a hazard may occur.

GREASING

Use an SAE multipurpose high temperature grease with extreme pressure (EP) performance. Also acceptable is an SAE multipurpose lithium-based grease.

1. Use a Maintenance Checklist to keep record of all scheduled maintenance.
2. Use a hand-held grease gun for all greasing.
3. Wipe grease fitting with a clean cloth before greasing to avoid injecting dirt and grit.
4. Replace and repair broken fittings immediately.



If fittings will not take grease, remove and clean thoroughly. Also clean lubricant passageway. Replace fitting if necessary.

LUBRICANT

HUB CITY 90° BEVEL GEAR DRIVE. Model no. 175. Lube quantity is .70 Pints.

HUB CITY GEAR LUBRICANT GL-90. Part no. = 8-58-00-01-009.

HUB CITY LUBRICANT	AGMA NUMBER	ISO-ASTM VISCOSITY GRADE
GL - 90	5 EP	220

For bevel gear drives with ambient temperature of 15-125° F (-9 to 52° C) and operating temperature to 185° F (85° F).

Hub City GL-90 lubricant is a heavy duty industrial gear lubricant containing sulfur phosphorous antiwear additives. Lubricants of this general type and meeting the above specifications may be substituted where Hub City lubricants are recommended. Lubricant selected must be compatible with nitrile rubber seals.

SEED CONDITIONER



Do not operate unit without making sure it contains the correct amount of oil. Do not overfill or under fill with oil, or injury to personnel, unit or other equipment may result.

CHANGING LUBRICANT: After the first 100 hours of operation, drain out initial oil and flush out the gear case with an approved non-flammable, non-toxic solvent. Acceptable alternates include Whitmore's Flushing Oil (#066802030) or Medallian™ Flushing Oil Kosher (#06812010). After all solvent is drained, re-fill with lubricant. Thereafter, oil should be changed every 2500 operating hours or every 6 months, whichever occurs first.



Oil should be changed with greater frequency if the unit is used in a severe environment such as dusty or humid.

ELECTRICAL PANEL

1. Check and tighten wire connections.
2. Check quick connects on bottom of control panel.
3. Check to see if starters and/or overloads are tripped.
4. Check to see if relays, timers and/or breakers are tripped.
5. Check quick connects on end of Auxiliary cord.
6. Check and tighten wire connections.
7. Check relay and fuse holder.
8. Check power cords for cuts or frays and ensure ground is present.

SEED CONDITIONER

Proper care of the stainless steel wire mesh belt will assure a long life and satisfactory service life for the belt. In fact, with most installations, the service life of the belt is heavily predicated by the care it receives. One of the most important single factors is to make certain that the belt tracks satisfactorily so the edge is not damaged.

WIRE MESH BELT DRIVE ASSEMBLY

1. Remove chain drive guard. Clean all debris and dirt from the entire unit. Inspect all welds and structural components on the frame and belt components for bends, cracks and damage.
2. Inspect pillow block bearings and grease every 40 hours of operation.
3. Check drive chain tension and lubricate chain every 40 hours of operation.

WIRE MESH BELT TENSIONING

1. Inspect belt rollers and stainless steel mesh belt for unusual wear. If belt is slipping increase belt tension.
2. When increasing belt tension, do it from the inlet end only. It is also crucial that you move the tightening bolts the exact same number of turns on both sides of the belt. This will keep the belt alignment intact. Loosen the jam nuts on both sides of the drive roller bearing adjustment. Tighten both sides equally until desired tension, then tighten jam nuts. Run the belt under load to determine if the belt tension is correct. This process may need to be repeated several times. Whenever tightening the belt it is recommended that the belt alignment be checked before resuming production operation of the Seed Conditioner.

Loosen these jam nuts before adjusting the bearing position bolt

Use this bolt to tighten the belt

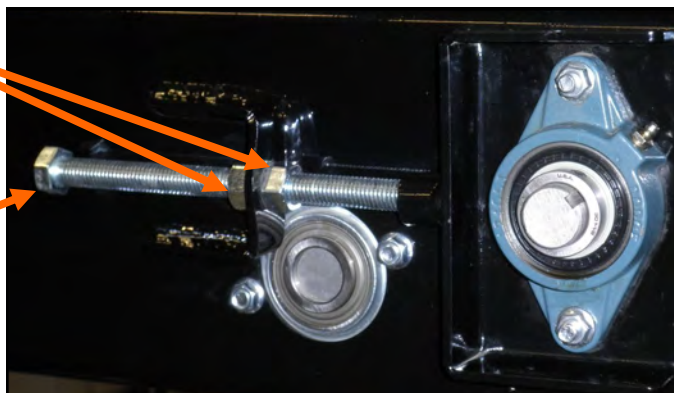

WIRE MESH BELT ALIGNMENT

Wire mesh belts are designed and built to run true when all rollers and support beds are level from left to right and at right angles to the centerline of the conveyor. It is essential that all drive rollers and take up rollers are mutually parallel. (see page 32) .

WIRE MESH BELT TRACKING

Tracking a wire mesh belt is accomplished by using the proper procedures. The most important principle is that a wire mesh belt always tracks in a direction perpendicular to the support rolls over which it passes. To track the belt in a particular direction, it is only necessary to skew the support rollers in the desired direction. Do not track the belt by moving the end rollers out of parallel. The following are the steps required to track a wire mesh belt.

1. Make certain the Seed Conditioner unit has been carefully aligned following the procedure described above and the diagrams on page 32.
2. Place at least one mark on the belt with paint or chalk to serve as a reference point in tracking adjustments.
3. Run the belt for several complete revolutions. On each revolution, measure the lateral position of the reference point on the inlet drive roller. This will indicate the direction and extent of lateral movement.
4. If adjustment are required , adjust the support rollers. The support rollers should be adjusted a measured distance in the direction of the discharge end and on the side of the conveyor where belt side travel is noted. Or, adjust the rollers towards the inlet end on the opposite side of the conveyor or both. It is important to keep in mind **always** that slight adjustments on each roller are more effective than large adjustments on one or two rollers.
5. Continue checking the lateral position of the reference point and making adjustments until the belt tracks on the inlet drive roller consistently in the proper position. At this point the belt is tracking in a repeating pattern.
6. Check the lateral position of the belt on the discharge roller. If it is satisfactory, tracking is complete.

BELT ADJUSTMENTS - ALIGNMENT - TRACKING

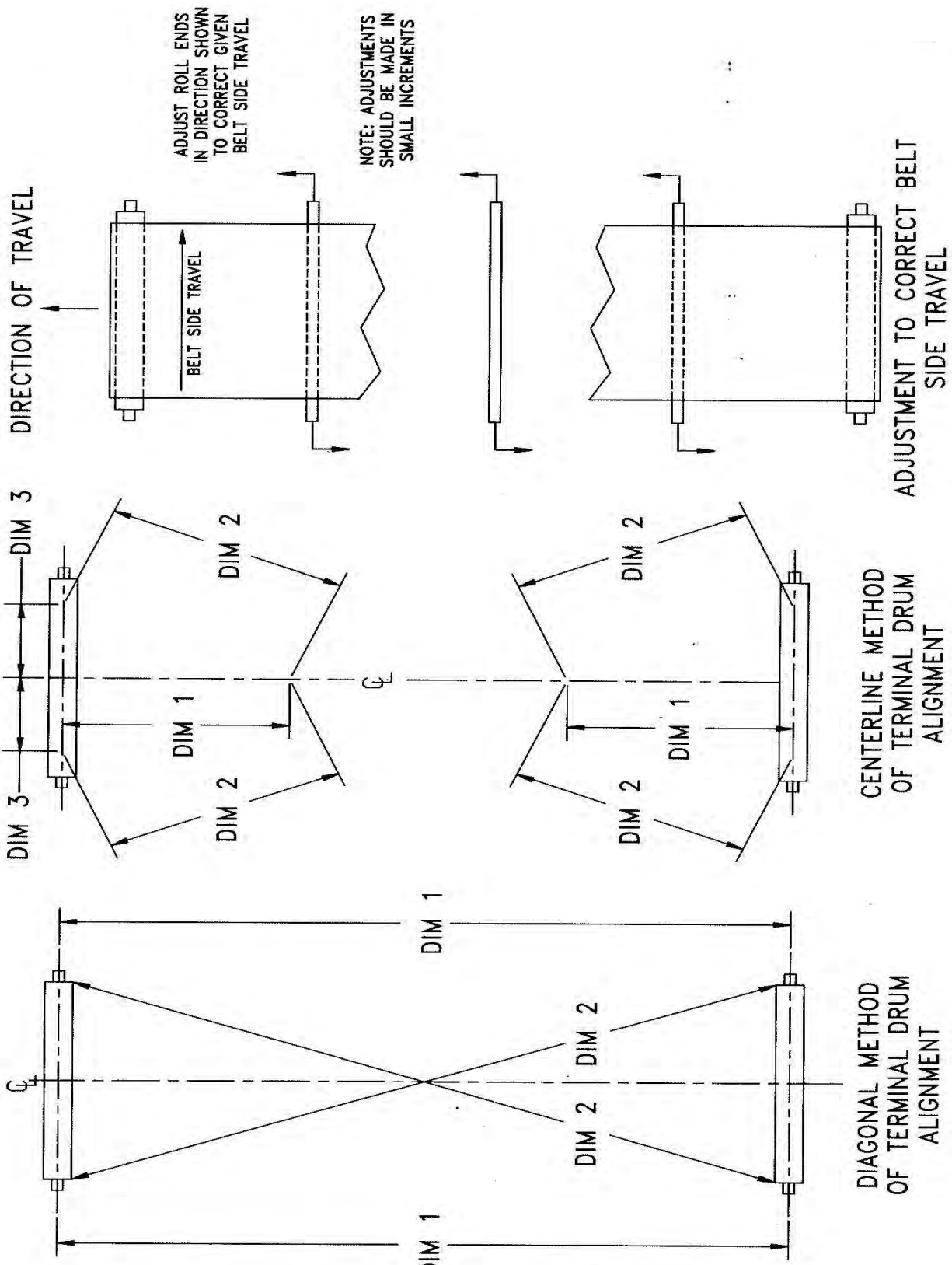

**BOTTOM OF BELT
SUPPORT LAYOUTS**

DIRECTION OF TRAVEL

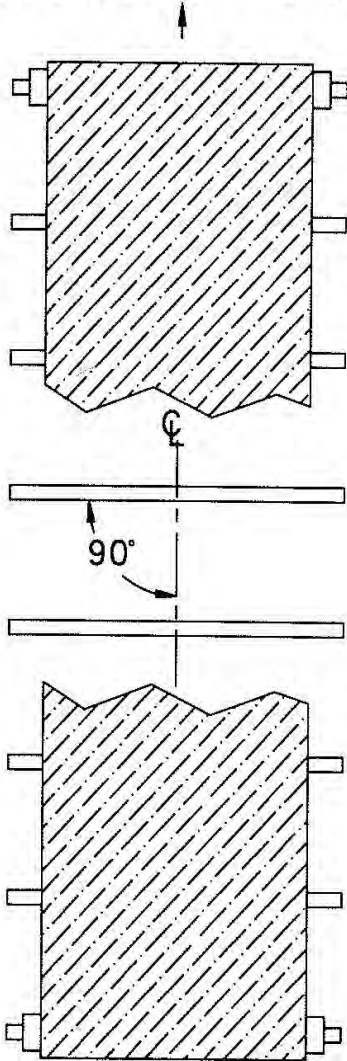

ROLLER SUPPORT

**TOP OF BELT
SUPPORT LAYOUTS**

DIRECTION OF TRAVEL

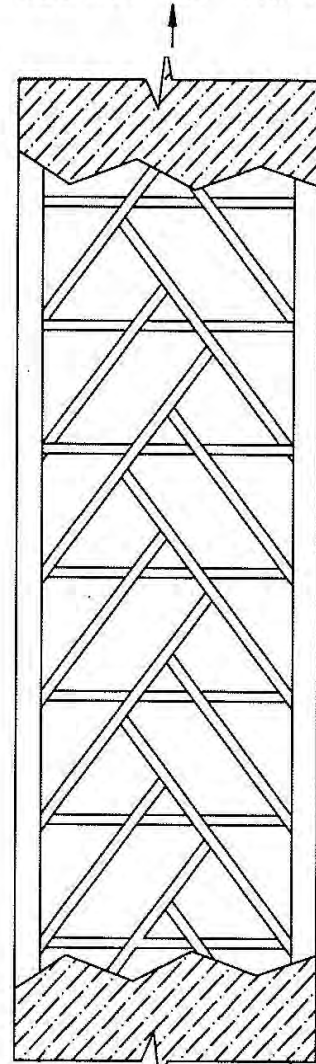

HERRINGBONE SUPPORT
WITH CROSS BARS

WIRE MESH BELT INSTALLATION

If a new wire mesh belt needs to be installed, contact the USC Service department at (785) 431-7900.

When storing the Seed Conditioner for long periods of time, the following procedure must be followed to reduce the chance of rust, corrosion and fatigue. You can also use these steps when storing the machine for the winter.



A dust mask and protective rubber gloves shall be used when cleaning the machine.

1. Clear the area of bystanders, especially small children.
2. Thoroughly wash the entire machine to remove all dirt, mud, debris or residue.
3. Inspect all moving or rotating parts to see if anything has become entangled in them. Remove the entangled material.
4. Lubricate all grease fittings. Make sure that all grease cavities have been filled with grease to remove any water residue from the washing. This also protects the bearing seals.
5. Remove drive assembly covers. Clean entire area and ensure drive chain is clean and free of debris. Lubricate drive chain.
6. Touch up all paint nicks and scratches to prevent rusting.
7. Store the machine inside a protective building to keep it from being exposed to the weather. Select an area that is dry, level and free of debris. If storing outside, cover with a waterproof tarpaulin.
8. Store machine in an area away from human activity.
9. Do not allow children to play on or around the stored machine.

SEED CONDITIONER

NOTES:

MECHANICAL DRAWINGS

SECTION H

TAIL END LEG ASSEMBLY (05-05-0120)

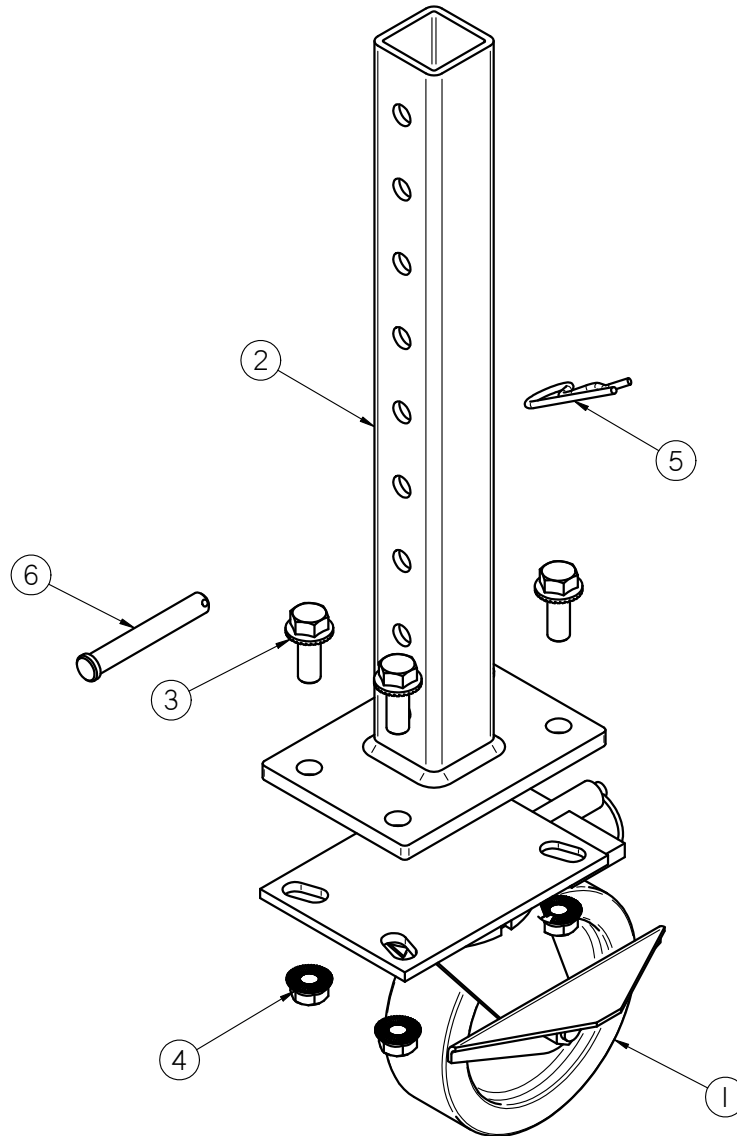

Item #	Part #	Description	Qty
1	01-06-0060	WHL CSTR 6.0 X 2.0 SWVL LOCK PHEN	1
2	05-05-0106	WDMT LEG ADJ SHORT 3013 DRYER	1
3	06-01-0232	BOLT FLG .500-13 X 1.250 ZP GR5	4
4	06-03-0015	NUT LOCK FLG .500-13 ZP GR5	4
5	06-09-0002	PIN CLIP HITCH 3.063 SIZE 9 ZP	1
6	06-09-0005	PIN CLVS .500 X 3.50 PLN	1

SEED CONDITIONER
DRIVE END LEG ASSEMBLY (05-05-0119)

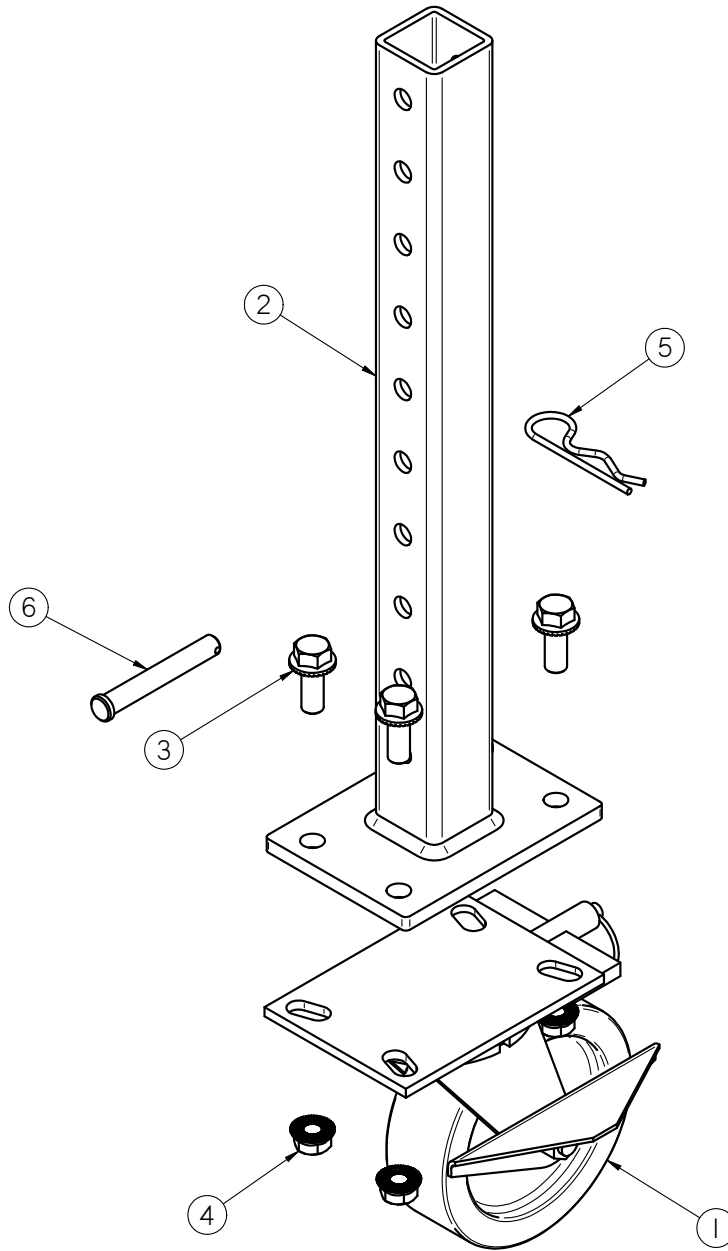

Item #	Part #	Description	Qty
1	01-06-0060	WHL CSTR 6.0 X 2.0 SWVL LOCK PHEN	1
2	05-05-0107	WDMT LEG ADJ TALL 3013 DRYER	1
3	06-01-0232	BOLT FLG .500-13 X 1.250 ZP GR5	4
4	06-03-0015	NUT LOCK FLG .500-13 ZP GR5	4
5	06-09-0002	PIN CLIP HITCH 3.063 SIZE 9 ZP	1
6	06-09-0005	PIN CLVS .500 X 3.50 PLN	1

SEED CONDITIONER
INLET DRIVE ROLLER ASSEMBLY (05-03-1564)

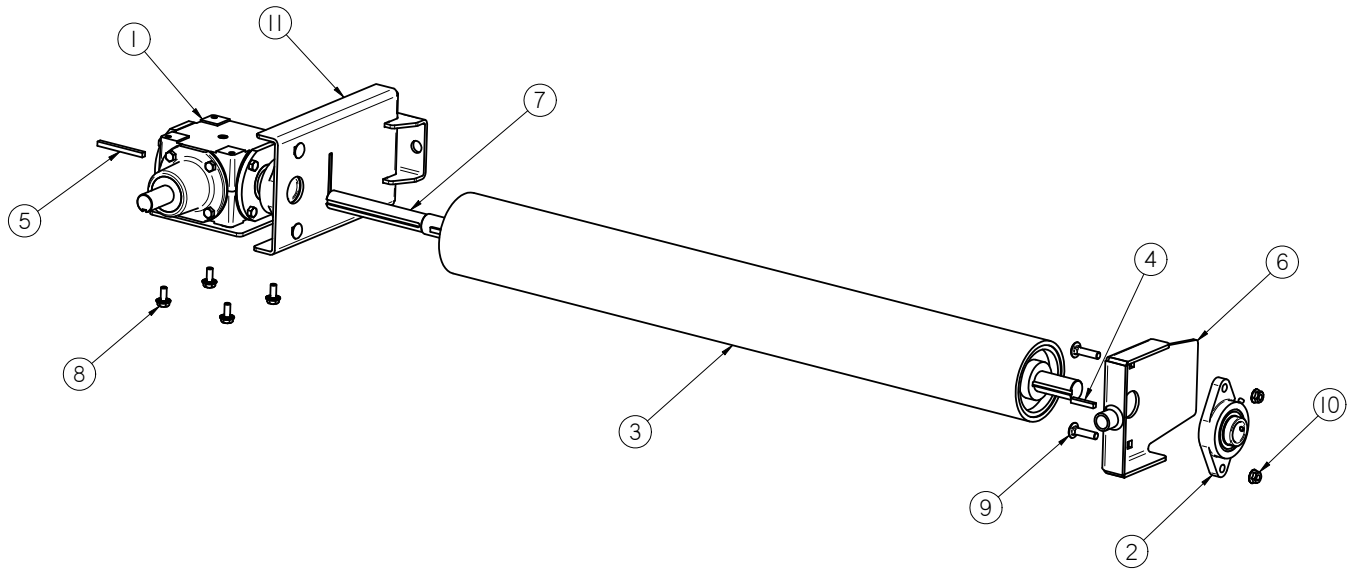

Item #	Part #	Description	Qty
1	01-01-0215	GBOX RA 1:1 1.0 HLW SHAFT	1
2	01-03-0031	BRG FLG MNT 1.125ID 2BOLT	2
3	01-06-0145	RLR CNVR 4.00OD X 1.125ID X 38.50	1
4	01-10-0005	1/4" KEY, CS - 1 1/2" LONG	2
5	01-10-0009	KEY .250 X 3 18-8 SS	1
6	05-07-0740	WDMT BRKT BRG MNT 2 BOLT	1
7	05-11-0404	SHAFT IDLER BELT RLR DRYER	1
8	06-01-0124	BOLT, FLG .375-16 UNC ZP GRADE 5; 3/4" LG	4
9	06-01-0128	BOLT, CARRIAGE, .375-16 X 1.50 G5 ZP	4
10	06-03-0014	NUT LOCK FLG .375-16 ZP GR5	4
11	103DA4	WDMT BRG TAKE UP	1

SEED CONDITIONER
BELT DRIVE ASSEMBLY (05-03-1566)

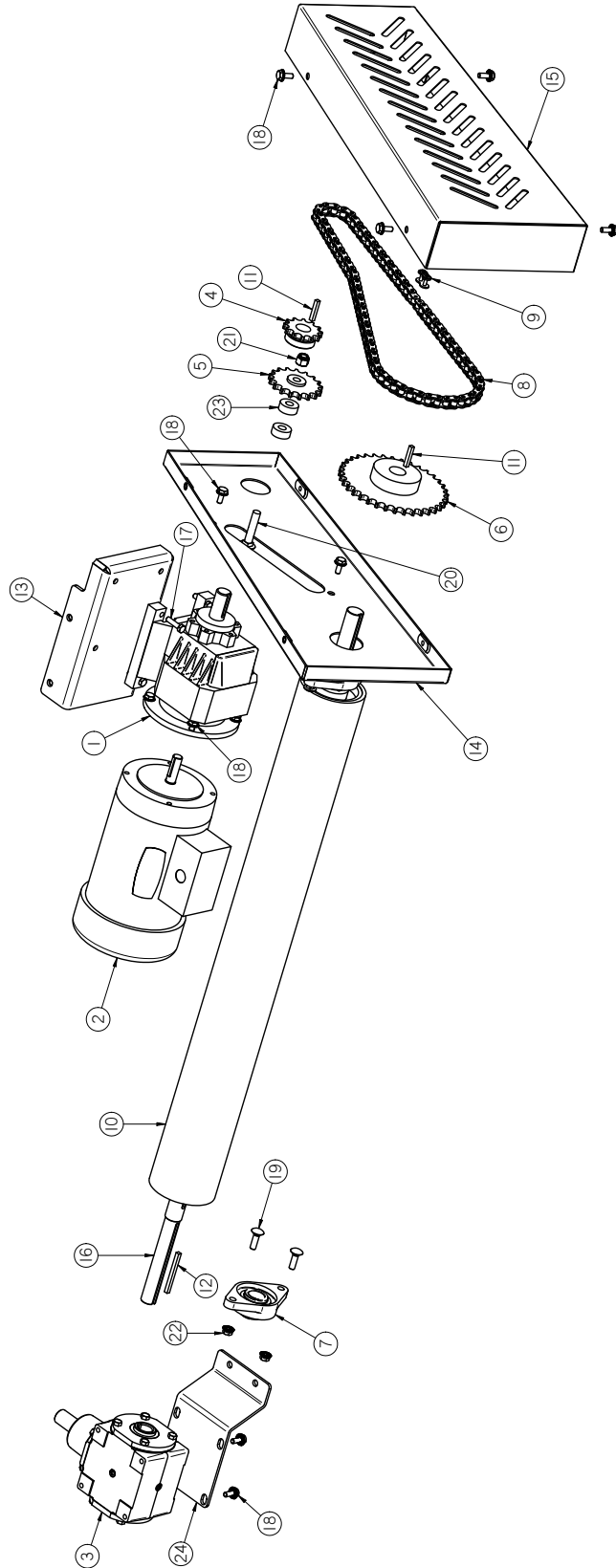

SEED CONDITIONER
BELT DRIVE ASSEMBLY (05-03-1566)

Item #	Part #	Description	Qty
1	01-01-0101	GBOX IL 56C 16.2:1 GR B1 FOOT MNT	1
2	01-01-0106	MTR 1.5HP 1725RPM TEFC 56C 3PH	1
3	01-01-0215	GBOX RA 1:1 1.0 HLW SHAFT	1
4	01-02-0076	Sprocket #50 12T 1.0000 in Bore Type B	1
5	01-02-0095	SPKT 17T 50P .500 ID IDLER	1
6	01-02-0119	SPKT 36T 50P 1.125ID KWY	1
7	01-03-0031	BRG FLG MNT 1.125ID 2BOLT	2
8	01-04-0002	CHAIN RLR 50 LENGTH 55.00"	1
9	01-04-0005	CHAIN CTNG LINK 50P	1
10	01-06-0145	RLR CNVR 4.00OD X 1.125ID X 38.50	1
11	01-10-0005	1/4" KEY, CS - 1 1/2" LONG	3
12	01-10-0009	KEY .250 X 3 18-8 SS	1
13	05-03-1477	WDMT MNT GBOX	1
14	05-06-0102	GRD BACK DRYER	1
15	05-06-0117	WDMT DRV GRD SEED CONDITIONER	1
16	05-11-0405	SHAFT DRV BELT RLR DRYER	1
17	06-01-0102	BOLT .313-18 X 1.25 ZP GR5	4
18	06-01-0124	BOLT FLG .375-16 X .750 ZP GR5	14
19	06-01-0127	BOLT CRG .375-16 X 1.25 ZP GR5	4
20	06-01-0280	BOLT CRG .500-13 X 2.75 ZP GR5	1
21	06-03-0004	NUT NYL LOCK .500-13 ZP GR5	1
22	06-03-0014	NUT LOCK FLG .375-16 ZP GR5	4
23	102FE7	SPCR IDLER SPKT	2
24	103D94	PLT GBOX MNT	1

SEED CONDITIONER

FAN #2 & FAN #3 HOOD ASSEMBLY (05-03-1563)

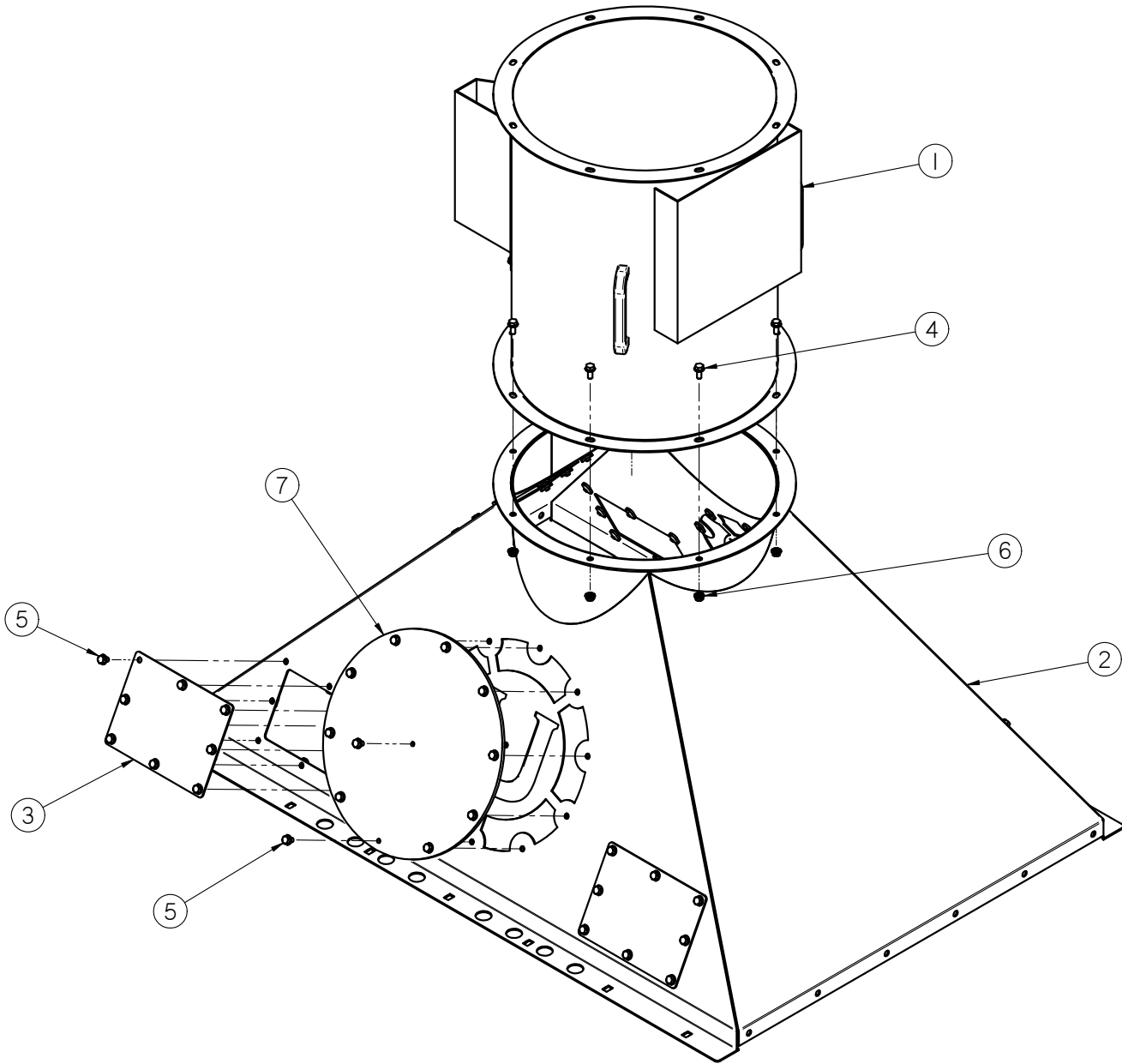

Item #	Part #	Description	Qty
1	01-13-0017	FAN AXIAL 18.OID 2HP 240V 3PH	1
2	05-07-0741	WDMT TRANS HOOD-FAN	1
3	5/10/4296	PLT CVR ACCESS	5
4	06-01-0138	BOLT, FLG .3125-18 UNC ZP GRADE 5; 3/4" LG	8
5	06-01-0261	BOLT FLG .3125-18 X .500 ZP GR5	62
6	06-03-0019	NUT LOCK FLG .3125-18 ZP GR5	8
7	102098	COVER	2

SEED CONDITIONER

FAN #1 HOOD ASSEMBLY (05-03-1565)

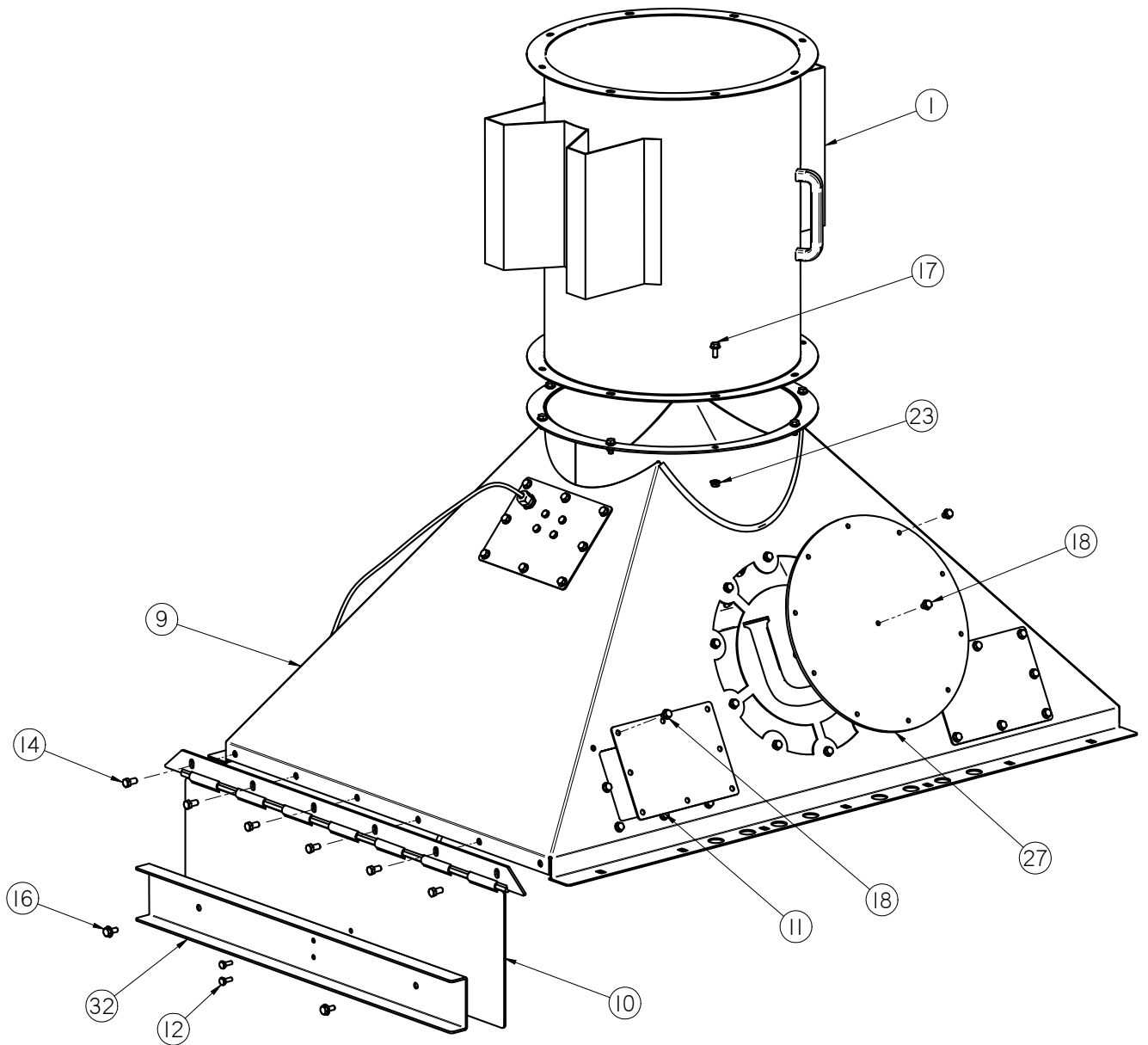

SEED CONDITIONER

INLET HOOD ASSEMBLY (05-03-1565)

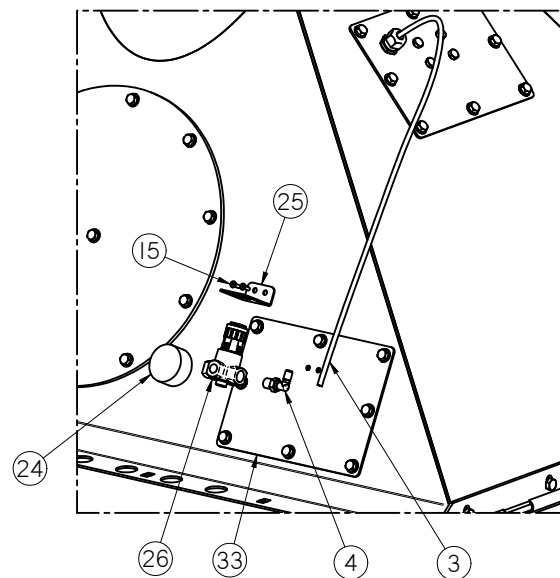
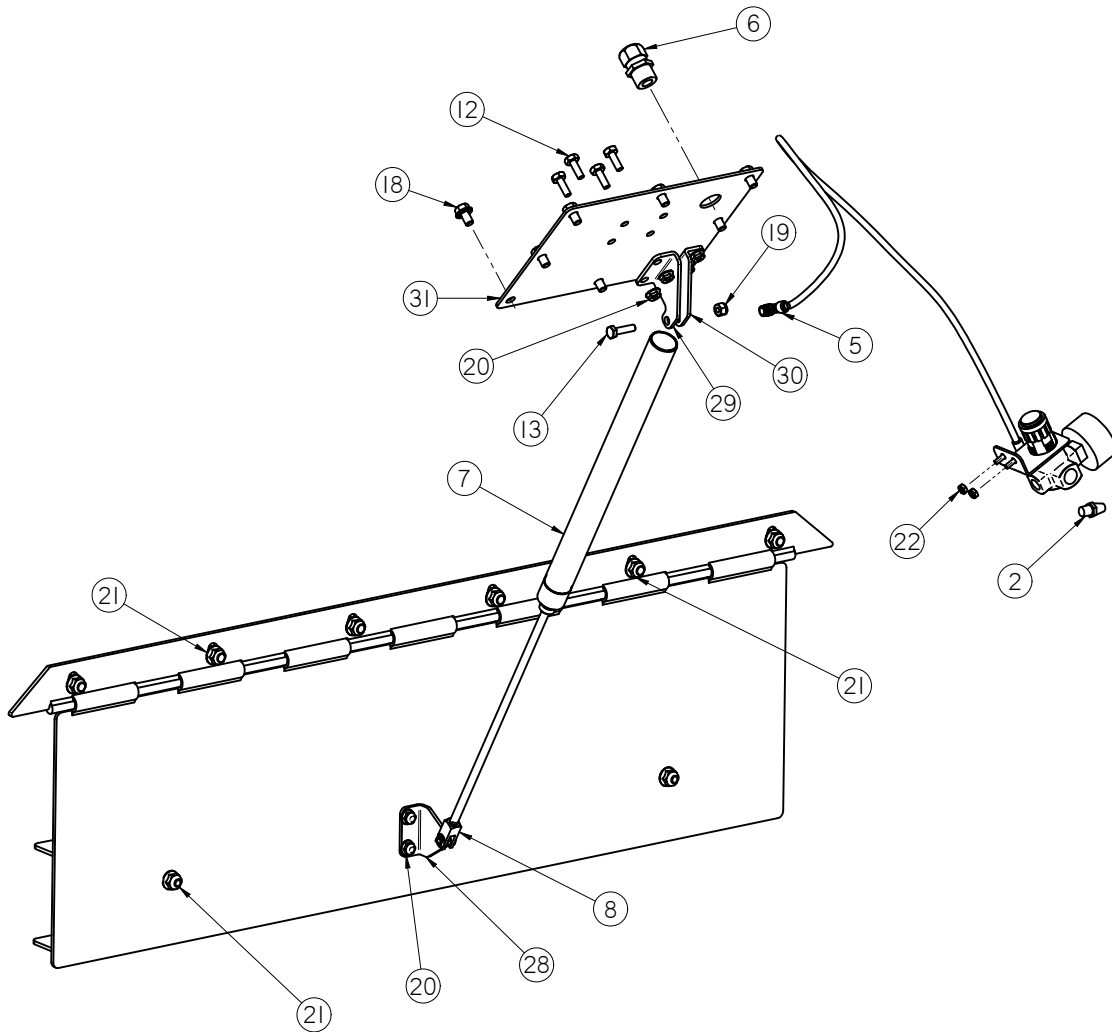

SEED CONDITIONER

INLET HOOD ASSEMBLY (05-03-1565)

Item #	Part #	Description	Qty
1	01-13-0017	FAN AXIAL 18.OID 2HP 240V 3PH	1
2	02-02-0049	FLTR EXHAUST BRZ .125 NPT	1
3	02-03-0008	TBG .250 OD POLYE COMP	1
4	02-16-0044	FTTG PUSH 90 DEG .250OD X .250 NPT	1
5	02-16-0046	FTTG PUSH 90 DEG .250 OD X .125 NPT	1
6	03-08-0064	CONN CG PLASTIC 0.5NPT .200-.472	1
7	03-17-0106	CYL AIR 1.0625 BORE X 12 STROKE	1
8	03-17-0107	CLEVIS ASSY BIMBA D-166-1	1
9	05-07-0741	WDMT TRANS HOOD-FAN	1
10	05-07-0795	WDMT INLET SWING GATE	1
11	05-10-4296	PLT CVR ACCESS	3
12	06-01-0003	BOLT, .250-20 X .750 UNC 18-8 SS	6
13	06-01-0007	BOLT, .250-20 X 1 UNC ZP GRADE 5	1
14	06-01-0015	BOLT .375-16 X 0.75 ZP GR5	6
15	06-01-0112	SCRW MACH 8-32X.500 ZP PN SLTD PHD	2
16	06-01-0124	BOLT, FLG .375-16 UNC ZP GRADE 5; 3/4" LG	2
17	06-01-0138	BOLT, FLG .3125-18 UNC ZP GRADE 5; 3/4" LG	8
18	06-01-0261	BOLT FLG .3125-18 X .500 ZP GR5	62
19	06-03-0001	NUT,LOCK, .250-20 ZP G5 NYLON INSERT	1
20	06-03-0013	NUT,LOCK, FLG .250-20 ZP SERRATTED	6
21	06-03-0014	NUT LOCK FLG .375-16 ZP GR5	8
22	06-03-0017	NUT,LOCK, #8-32 ZP NYLON INSERT	2
23	06-03-0019	NUT LOCK FLG .3125-18 ZP GR5	8
24	07-03-0003	GAUGE 0/30 .25 NPT ML	1
25	07-03-0004	REG MNT BRKT	1
26	07-03-0017	REGULATOR 0-30 PSI .25"NPT	1
27	102098	COVER	2
28	103D48	CLYINDER MNT	1
29	103D4C	CLYINDER MNT	1
30	103D50	CLYINDER MNT	1
31	103D5A	PLT CYL ACCESS	1
32	103D5B	PLT DOOR GUSSET	1
33	103DCD	PLT CVR ACCESS	1

SEED CONDITIONER

FRAME ASSEMBLY (05-03-1562)

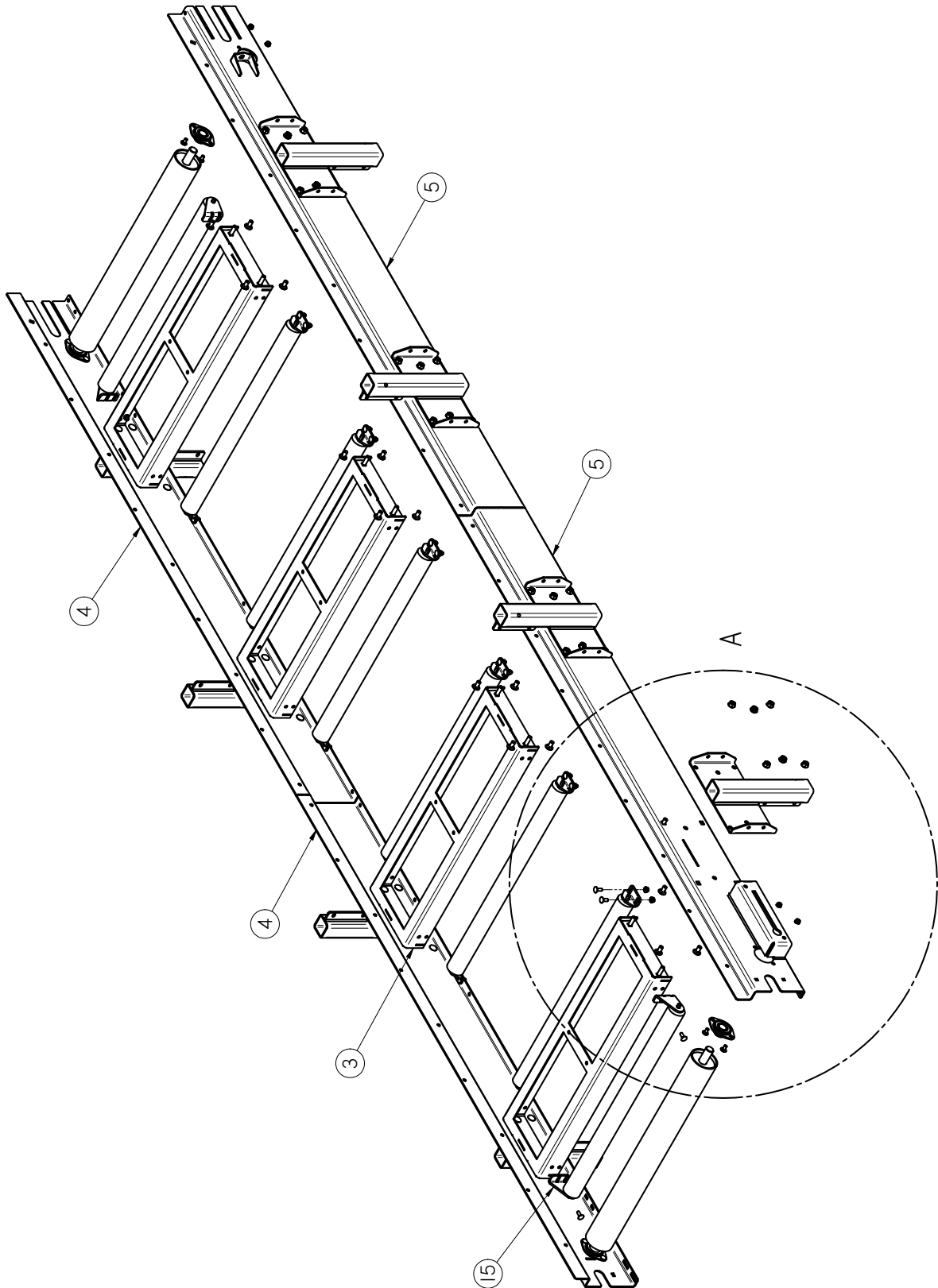

SEED CONDITIONER

FRAME ASSEMBLY (05-03-1562)

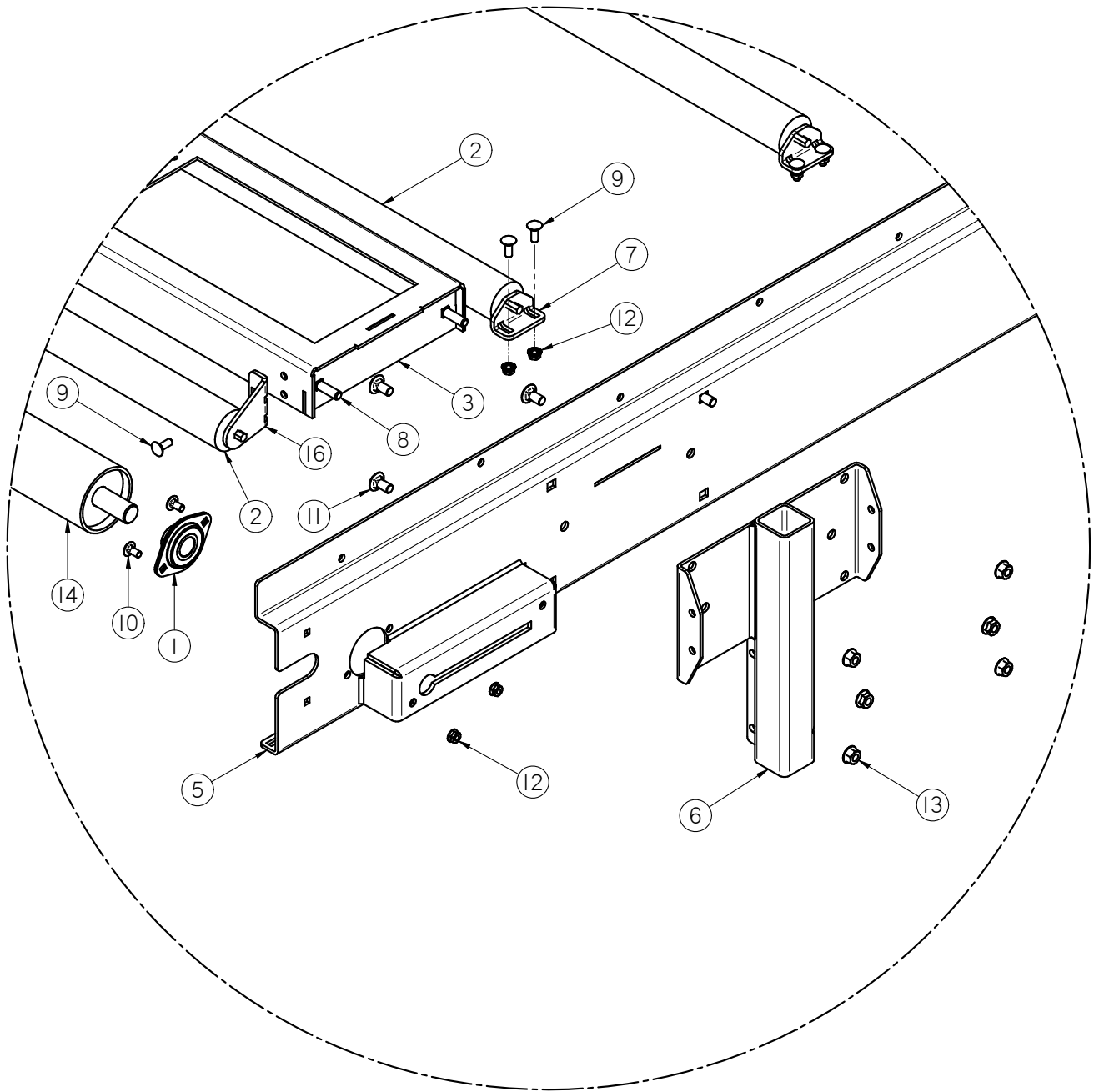

DETAIL A

SEED CONDITIONER

FRAME ASSEMBLY (05-03-1562)

Item #	Part #	Description	Qty
1	01-03-0066	BRG STAMPED FLG 1.125 BORE 2 BOLT	4
2	01-06-0146	RLR CNVR 2.50 OD 36.00 W .437 HEX	8
3	05-03-1473	WDMT SPCR CROSS	4
4	05-03-1475	WDMT FR DRYER LT	1
5	05-03-1476	WDMT FR DRYER RT	1
6	05-05-0114	WDMT LEG HOLDER DRYER	8
7	5/10/4289	PLT SUPP RLR RETURN	12
8	06-01-0026	BOLT CRG .500-13 X 1.75 ZP GR5	16
9	06-01-0115	BOLT CRG .375-16 X 1.00 ZP GR5	32
10	06-01-0153	BOLT CRG .375-16X.750 ZP SHORT NECK	8
11	06-01-0270	BOLT CRG .500-13 X 1.00 ZP GR5	32
12	06-03-0014	NUT LOCK FLG .375-16 ZP GR5	40
13	06-03-0015	NUT LOCK FLG .500-13 ZP GR5	48
14	1039D5	WDMT PLY IDLER	2
15	103A1B	PLT SUPP RLR RETURN	2
16	103A46	PLT SUPP RLR RETURN	2

SEED CONDITIONER

CONTROL PANEL MOUNT ASSEMBLY (05-07-0796)

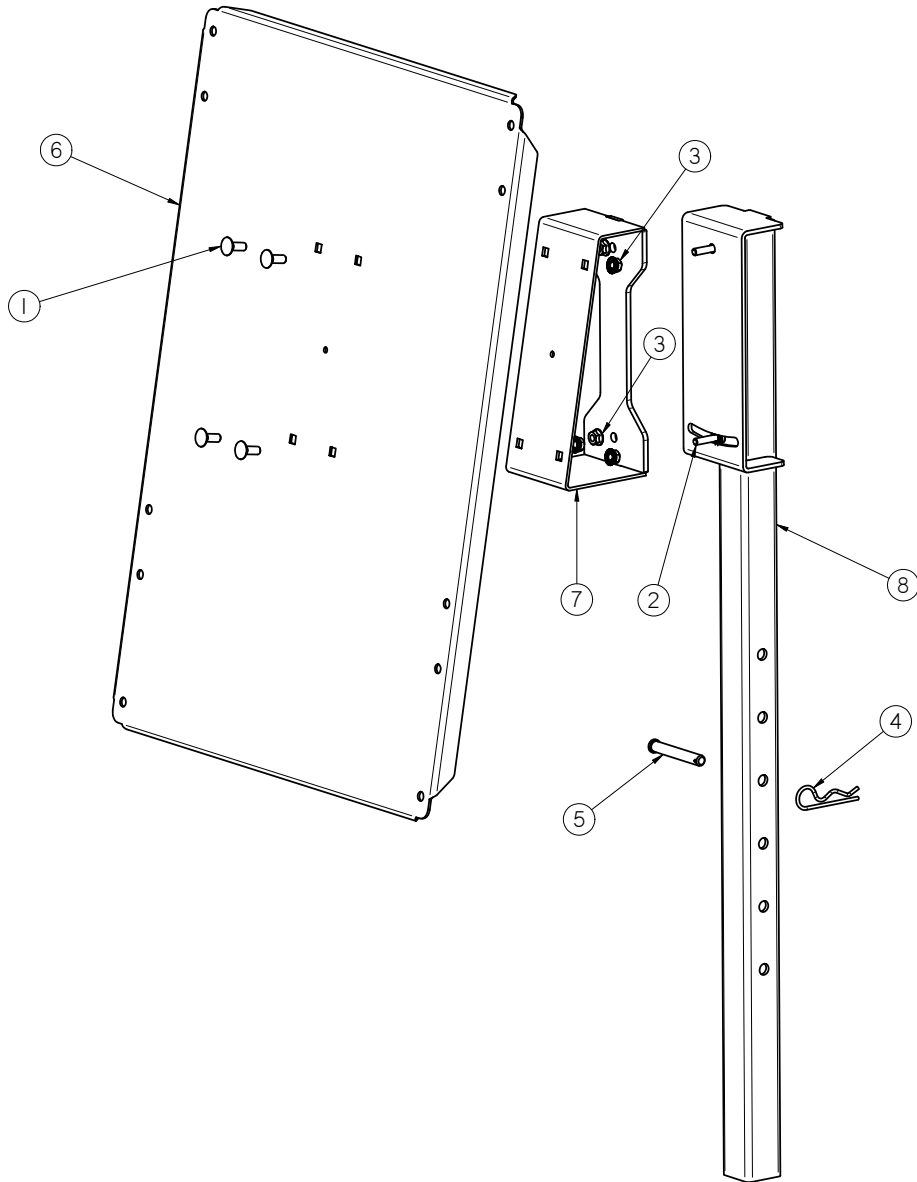

Item #	Part #	Description	Qty
1	06-01-0115	BOLT CRG .375-16 X 1.00 ZP GR5	4
2	06-01-0189	BOLT, FLG .375-16 UNC ZP GRADE 5; 1-1/4" LG	2
3	06-03-0014	NUT LOCK FLG .375-16 ZP GR5	6
4	06-09-0002	PIN CLIP HITCH 3.063 SIZE 9 ZP	1
5	06-09-0005	PIN CLVS .500 X 3.50 PLN	1
6	103D87	PLT PNL DRYER	1
7	103D89	WDMT PANEL MNT	1
8	103D8D	WDMT PANEL STAND	1

SEED CONDITIONER
SEED CONDITIONER BASE ASSEMBLY (13-16-0003)

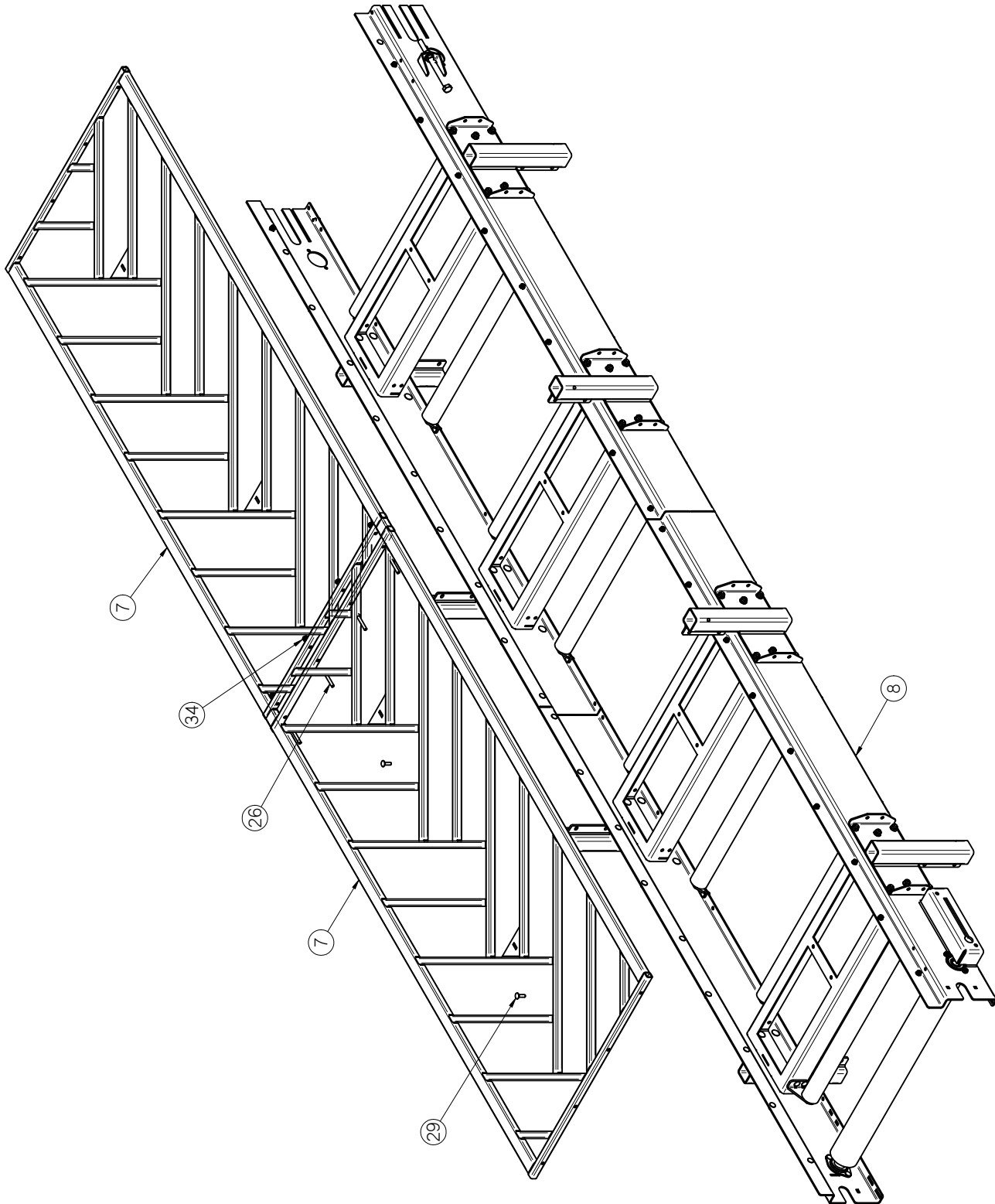

SEED CONDITIONER
SEED CONDITIONER BASE ASSEMBLY (13-16-0003)

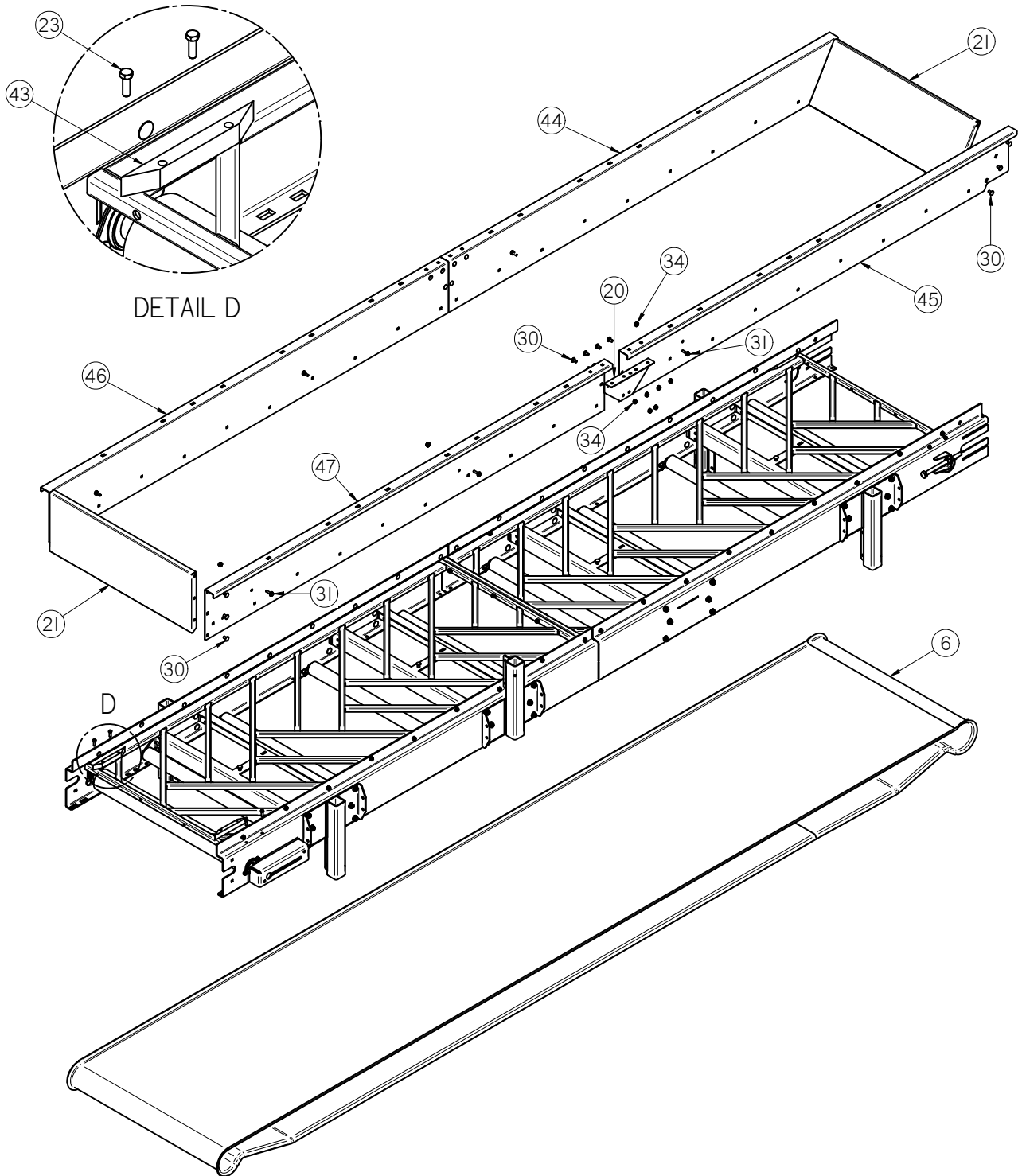

SEED CONDITIONER
SEED CONDITIONER BASE ASSEMBLY (13-16-0003)

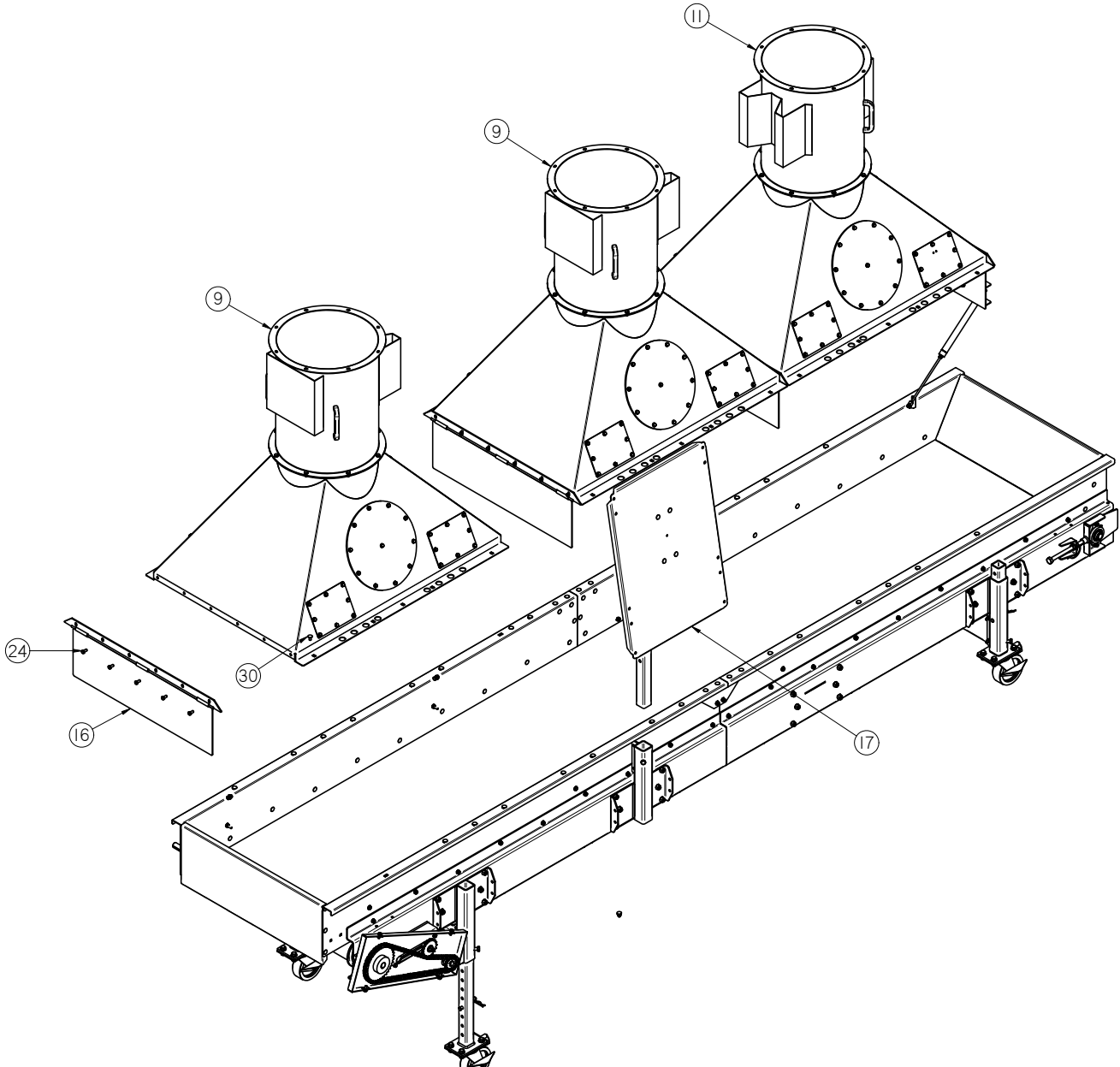

SEED CONDITIONER
SEED CONDITIONER BASE ASSEMBLY (13-16-0003)

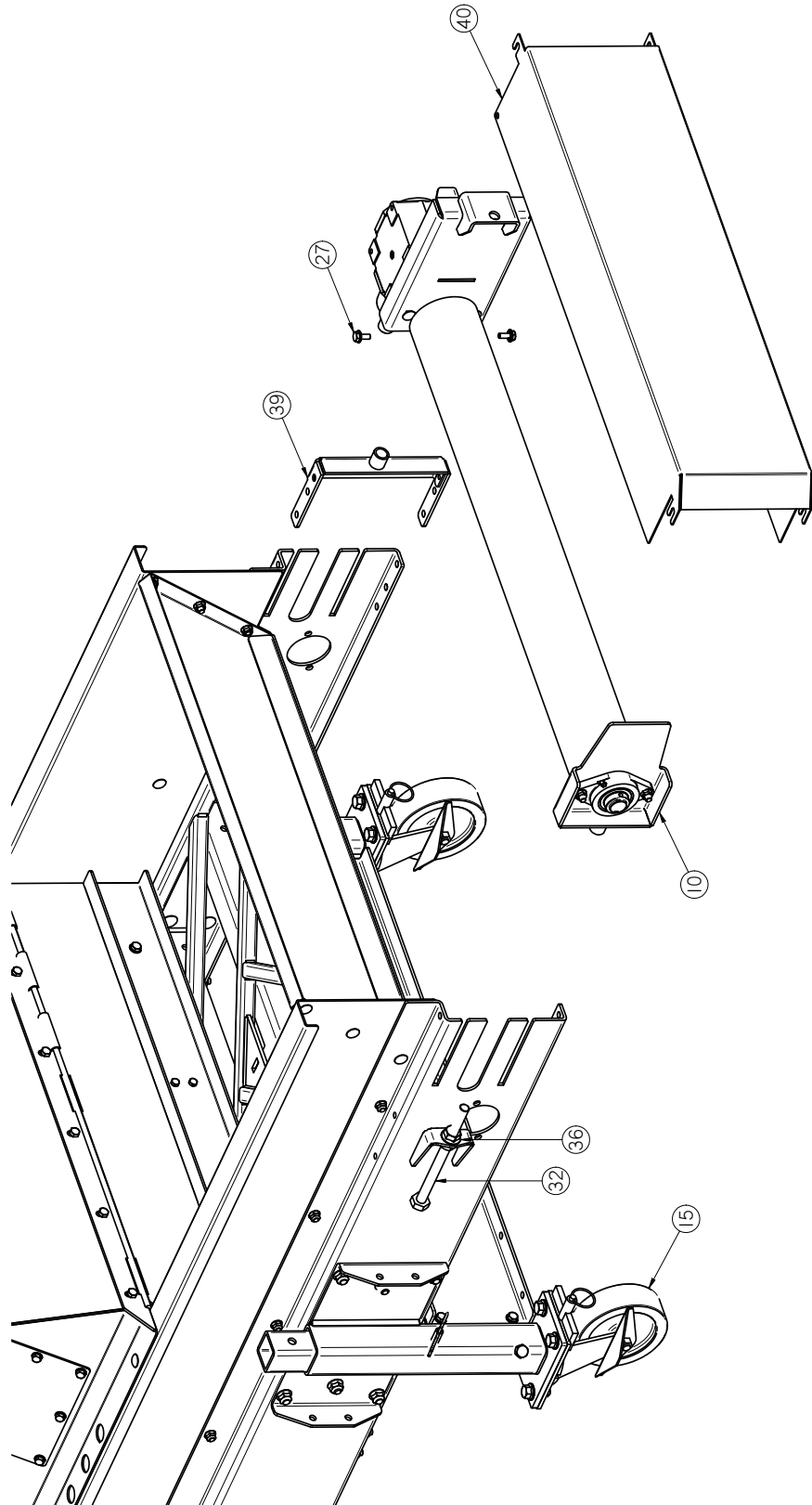

SEED CONDITIONER
SEED CONDITIONER BASE ASSEMBLY (13-16-0003)

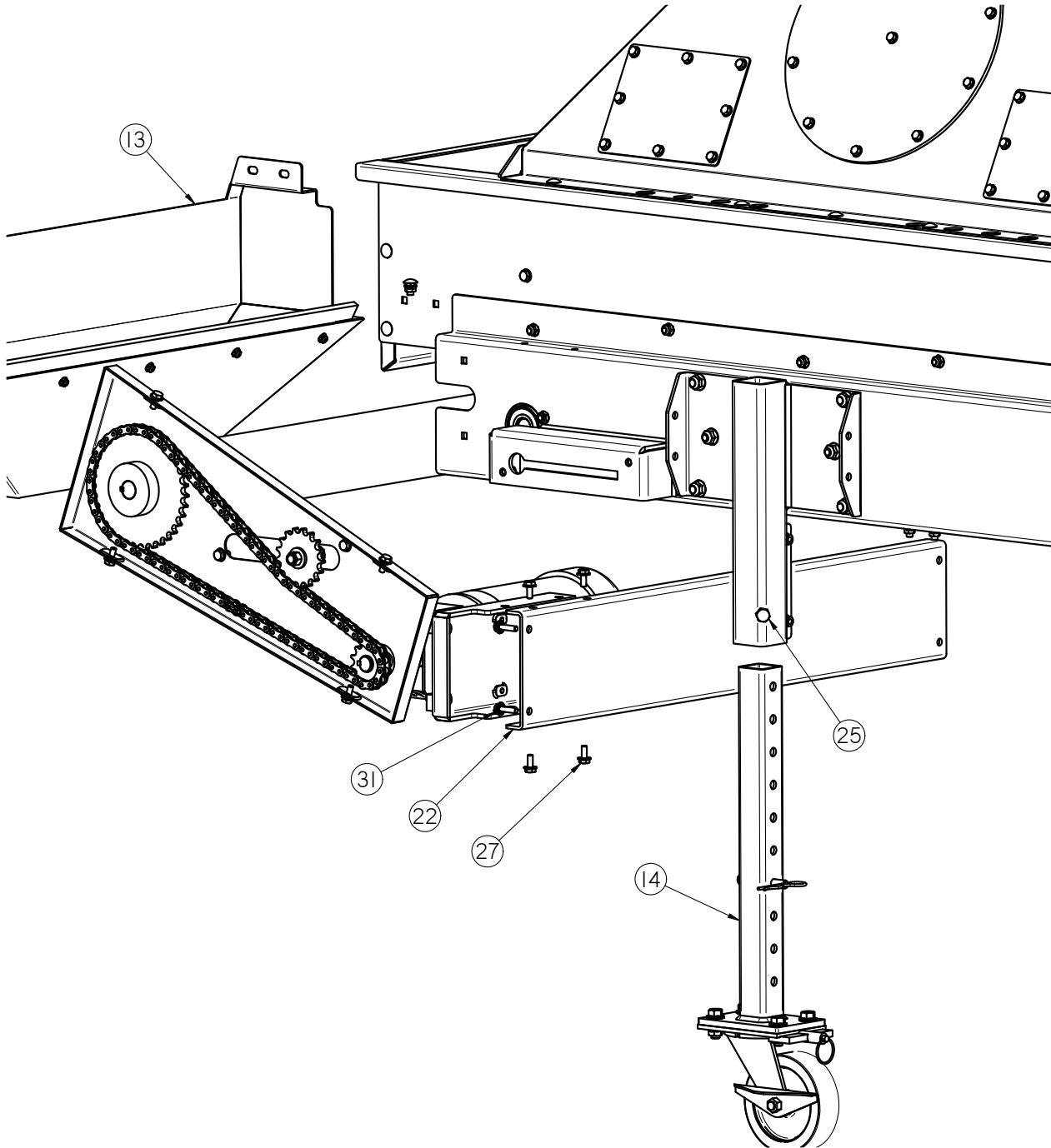

SEED CONDITIONER
SEED CONDITIONER BASE ASSEMBLY (13-16-0003)

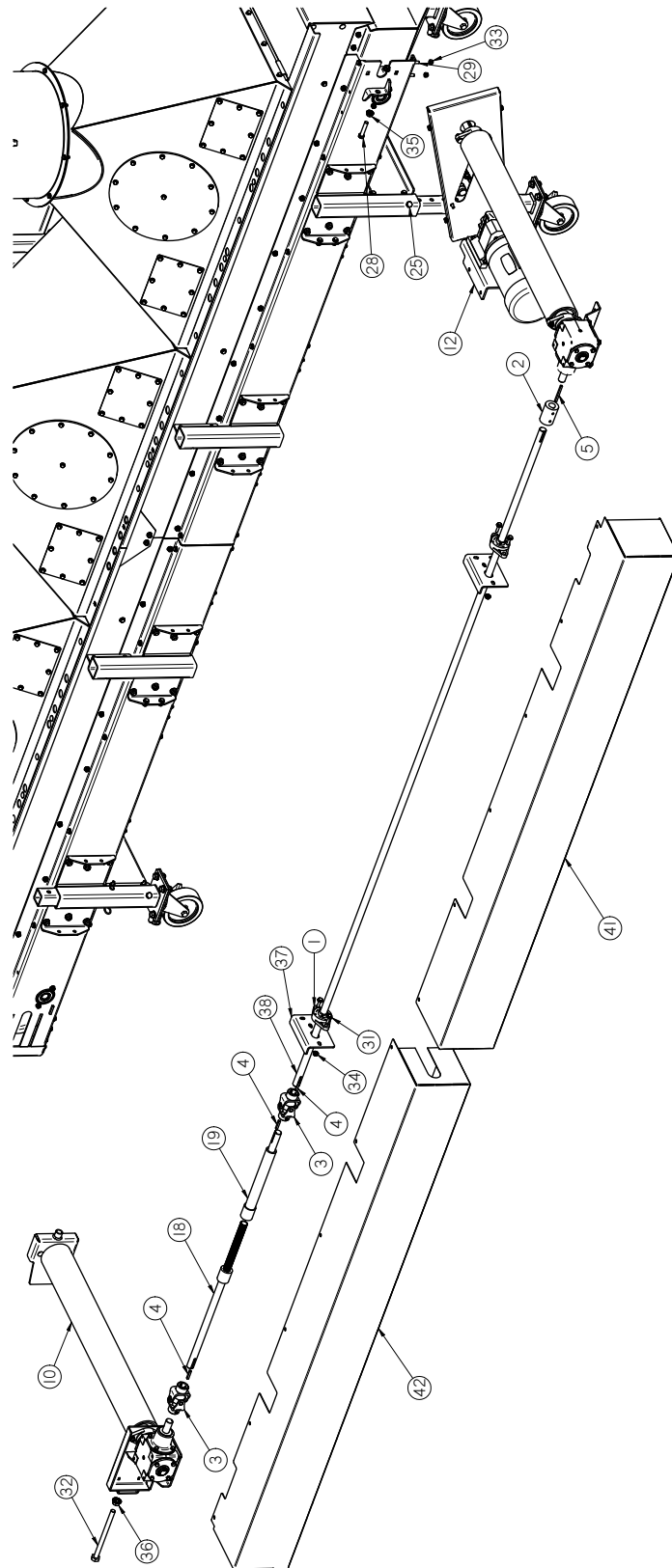

SEED CONDITIONER

SEED CONDITIONER BASE ASSEMBLY (13-16-0003)

Item #	Part #	Description	Qty
1	01-03-0003	BRG FLG MNT 1.000ID 2BOLT	2
2	01-07-0017	1" SHAFT COUPLING W/ KEYWAY	1
3	01-09-0007	U JOINT 1.0 BORE KEYWAY	2
4	01-10-0005	1/4" KEY, CS - 1 1/2" LONG	4
5	01-10-0009	KEY .250 X 3 18-8 SS	1
6	01-12-0003	BELT WIRE SS 36IN X 32FT BLNC RTU	1
7	05-03-1474	WDMT FR SUPP WIRE BELT	2
8	05-03-1562	ASSY 3613 COND FRAME	1
9	05-03-1563	ASSY 3613 HOOD	2
10	05-03-1564	ASSY 3613 TAIL SECT	1
11	05-03-1565	ASSY 3613 INLET HOOD	1
12	05-03-1566	ASSY 3613 DRIVE SECT	1
13	05-03-1625	ASSY DSCHG CHUTE SEED COND	1
14	05-05-0119	ASSY LEG DRV END	2
15	05-05-0120	ASSY LEG TAIL END	2
16	05-07-0742	WDMT DOOR DRYER ZONE	3
17	05-07-0796	ASSY PANEL MNT SEED COND	1
18	05-07-0797	WDMT SPLINE SHAFT	1
19	05-07-0798	WDMT SPLINE BUSHING	1
20	05-10-4294	PLT GUIDE JOINT	2
21	05-10-4295	PLT PRODUCT GUIDE END	2
22	05-10-4297	PLT LEG BRACE-MTR MNT	2
23	06-01-0012	BOLT .313-18 X 1.00 ZP GR5	8
24	06-01-0015	BOLT .375-16 X 0.75 ZP GR5	18
25	06-01-0024	BOLT .500-13 X .750 ZP GR5	5
26	06-01-0071	BOLT .375-16 X 2.50 ZP GR5	4
27	06-01-0124	BOLT FLG .375-16 X .750 ZP GR5	37
28	06-01-0125	BOLT .500-13 X 2.50 ZP GR5 FTH	1
29	06-01-0127	BOLT CRG .375-16 X 1.25 ZP GR5	6
30	06-01-0153	BOLT CRG .375-16X.750 ZP SHORT NECK	101
31	06-01-0189	BOLT FLG .375-16 X 1.250 ZP GR5	18
32	06-01-0249	BOLT .625-11 X 9.00 ZP GR5 FTH	2
33	06-03-0003	NUT NYL LOCK .375-16 ZP GR5	2
34	06-03-0014	NUT LOCK FLG .375-16 ZP GR5	150
35	06-03-0015	NUT LOCK FLG .500-13 ZP GR5	2

SEED CONDITIONER

SEED CONDITIONER BASE ASSEMBLY (13-16-0003)

Item #	Part #	Description	Qty
36	06-03-0029	NUT WHIZ LOCK FLG .625-11 GR5	4
37	103D99	PLT BRG MNT	2
38	103D9F	DRIVE SHAFT	1
39	103DA3	WDMT TAKE UP STOP	1
40	103DA7	PLT TAIL GUARD	1
41	103DA8	PLT GUARD DRV END	1
42	103DBA	PLT DRV GUARD INLET	1
43	104121	SEED COND BELT GUIDE	4
44	104603	PLT PRODUCT GUIDE DSCHG LT	1
45	104604	PLT PRODUCT GUIDE DSCHG RT	1
46	104605	PLT PRODUCT GUIDE INLET LT	1
47	104608	PLT PRODUCT GUIDE INLET RT	1

SEED CONDITIONER
SEED CONDITIONER FINAL ASSEMBLY

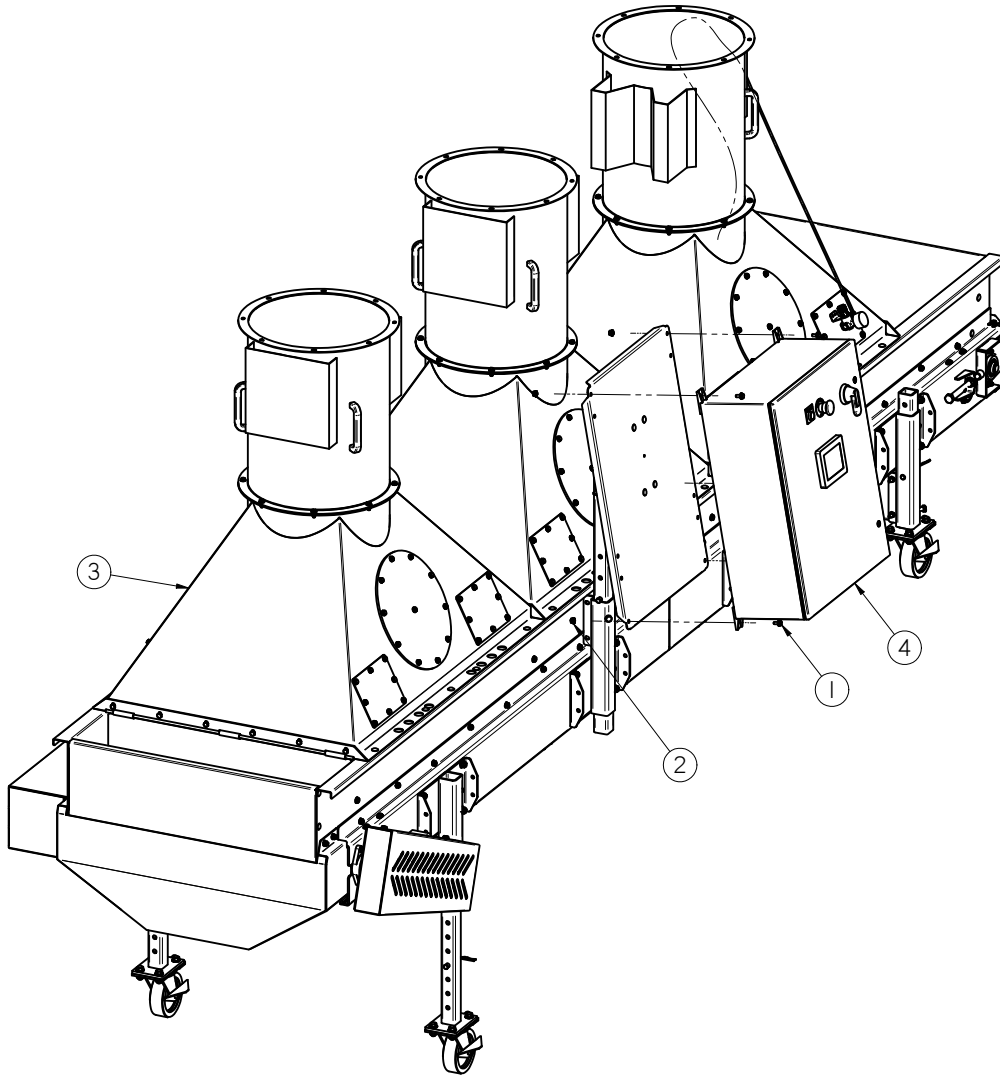

Item #	Part #	Description	Qty
1	06-01-0124	BOLT FLG .375-16 X .750 ZP GR5	4
2	06-03-0014	NUT LOCK FLG .375-16 ZP GR5	4
3	13-16-0003	BASE ASSY 3613 SEED COND	1
4	SEE TABLE 1	SEED CONDITIONER MAIN CNTRL PNL	1

TABLE 1	
Part #	Description
03-12-0380	CONTROL PANEL 230V 1PH
03-12-0383	CONTROL PANEL 230V 3PH
03-12-0384	CONTROL PANEL 460V 3PH
03-12-0385	CONTROL PANEL 575V 3PH

USC LIMITED WARRANTY**SECTION
I**

USC, LLC, (Manufacturer) warrants its seed treating equipment as follows:

1. **Limited Warranty:** Manufacturer warrants that the Products sold hereunder will be free from defects in material and workmanship for a period of 18 months from date of shipment. If the Products do not conform to this Limited Warranty during the warranty period, Buyer shall notify Manufacturer in writing of the claimed defects and demonstrate to Manufacturer satisfaction that said defects are covered by this Limited Warranty. If the defects are properly reported to Manufacturer within the warranty period, and the defects are of such type and nature as to be covered by this warranty, Manufacturer shall, at its expense, furnish replacement Products or, at Manufacturer's option, replacement parts for the defective products. Shipping and installation of the replacement Products or replacement parts shall be at the Buyer's expense.
2. **Other Limits:** THE FOREGOING IS IN LIEU OF ALL OTHER WARRANTIES, EXPRESSED OR IMPLIED, INCLUDING BUT NOT LIMITED TO THE IMPLIED WARRANTIES OF MERCHANTABILITY AND FITNESS FOR A PARTICULAR PURPOSE. Manufacturer does not warrant against damages or defects arising from improper installation (where installation is by persons other than Manufacturer), against defects in products or components not manufactured by Manufacturer, or against damages resulting from such non-Manufacturer made products or components. Manufacturer passes on to the Buyer the warranty it received (if any) from the maker of such non-Manufacturer made products or components. This warranty also does not apply to Products upon which repairs and / or modifications have been effected or attempted by persons other than pursuant to written authorization by Manufacturer. This includes any welding on equipment which could damage electrical components. Manufacturer does not warrant against casualties or damages resulting from misuse and / or abuse of Products, improper storage or handling, acts of nature, effects of weather, including effects of weather due to outside storage, accidents, or damages incurred during transportation by common carrier.
3. **Exclusive Obligation:** THIS WARRANTY IS EXCLUSIVE. The sole and exclusive obligation of Manufacturer shall be to repair or replace the defective Products in the manner and for the period provided above. Manufacturer shall not have any other obligation with respect to the Products or any part thereof, whether based on contract, tort, strict liability or otherwise. Under no circumstances, whether based on this Limited Warranty or otherwise, shall Manufacturer be liable for lost profits, lost revenue, lost sales (whether direct or indirect damages), incidental, special, punitive, indirect or consequential damages.
4. **Other Statements:** Manufacturer's employees or representatives' oral or other written statements do not constitute warranties, shall not be relied upon by Buyer, and are not a part of the contract for sale or this limited warranty.
5. **Return Policy:** Approval is required prior to returning goods to Manufacturer. A restocking fee will apply.
6. **Entire Obligation:** This Limited Warranty states the entire obligation of Manufacturer with respect to the Products. If any part of this Limited Warranty is determined to be void or illegal, the remainder shall remain in full force and effect.

US / Canada Non-Exclusive 2016



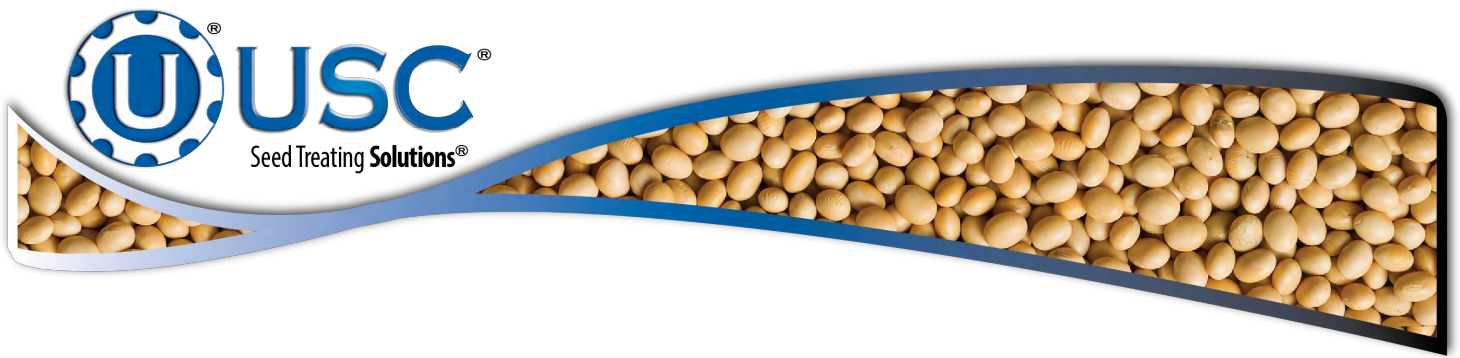

USC, LLC

2320 124th road

Sabetha, KS 66534

PHONE: (785) 431-7900

FAX: (785) 431-7950

EMAIL: sales-team@uscllc.com

WEB: www.uscllc.com

