

# HUB CHEMICAL BLENDING SYSTEM

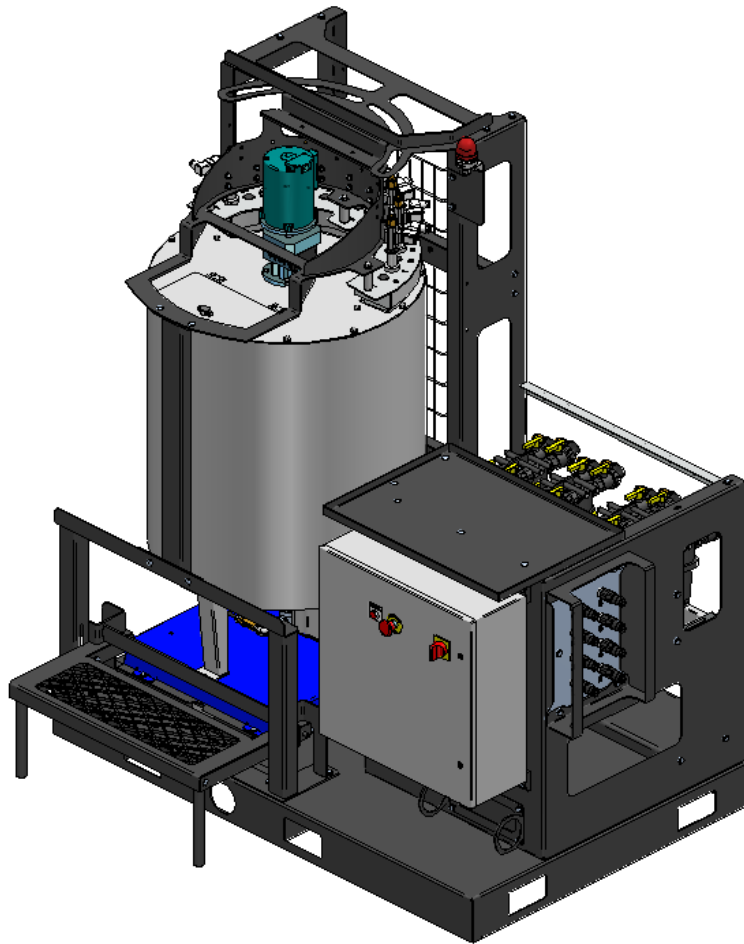

## OPERATOR'S MANUAL

Document: TD-09-06-1073

Revision: D

Effective Date: 02-2024

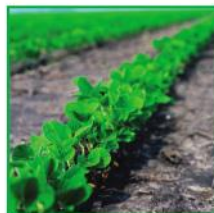

# INTRODUCTION

Thank you for choosing USC, LLC for your equipment needs. We appreciate your business and will work diligently to ensure that you are satisfied with your choice.

## OVERVIEW

The purpose of this manual is to provide you with the basic information needed to operate and maintain the Product Batching System. It does not hold USC, LLC liable for any accidents or injuries that may occur.

The technical information provided in this document is based on extensive testing under controlled conditions at the USC research and development facility. This information is given without guarantee as the conditions of operation and storage of the equipment are beyond our control. Variables such as temperature, humidity, viscosity of chemical products and changes in seed size or variety may all effect the accuracy of application and seed coverage. Periodically check the equipment calibration while treating and make adjustments as required. This will insure the optimum seed coverage.

## RECEIVING YOUR EQUIPMENT

As soon as the equipment is received, it should be carefully inspected to make certain that it has sustained no damage during shipment and that all items listed on the packing list are accounted for. If there is any damage or shortages, the purchaser must immediately notify USC, LLC. Ownership passes to purchaser when the unit leaves the USC, LLC. premises. The purchaser is responsible for unloading and mounting all components of the equipment.

Document the serial number of the machine for future reference. The serial number is located on the alarm horn bracket.

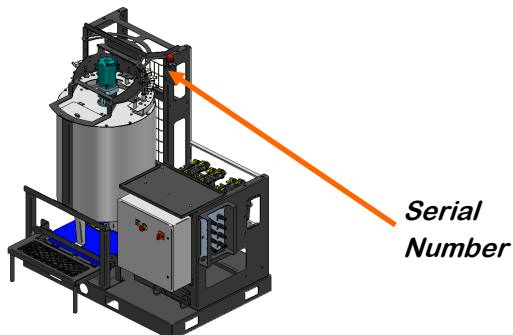

**SERIAL NUMBER:** \_\_\_\_\_

# TABLE OF CONTENTS

<b><u>Section</u></b>	<b><u>Contents</u></b>	<b><u>Page #</u></b>
<b>Section A</b>	<b>Safety Instructions</b> .....	<b>4</b>
	Safety Labels .....	11
<b>Section B</b>	<b>Installation Instructions</b> .....	<b>13</b>
	Keg Transfer Pump Installation .....	13
	Electrical Connections.....	14
	Scale Calibration .....	17
	Customer Supplied Pump Specifications .....	19
<b>Section C</b>	<b>Electrical and Automation</b> .....	<b>20</b>
	Main Screen .....	21
	HOA Screen .....	27
	Run Configuration Screen .....	29
	Report Screen .....	30
	Alarm Screen .....	32
	Alarm Codes .....	33
	Message Screen .....	35
	Ingredient Calibration .....	37
Automated Fill Operation .....	38	
<b>Section D</b>	<b>Troubleshooting</b> .....	<b>42</b>
<b>Section E</b>	<b>Maintenance</b> .....	<b>43</b>
	Mix Tank, Hoses, Pumps .....	43
	Filters, Electrical Panel, Valves, General System .....	44
<b>Section F</b>	<b>Storage</b> .....	<b>45</b>
<b>Section G</b>	<b>Limited Warranty</b> .....	<b>46</b>

## SECTION A

**SAFETY INSTRUCTIONS**

Every year accidents in the work place maim, kill and injure people. Although it may be impossible to prevent all accidents, with the right combination of training, operating practices, safety devices, and operator vigilance, the number of accidents can be significantly reduced. The purpose of this section is to educate equipment users about hazards, unsafe practices, and recommended hazard avoidance techniques.

If any of the required regularly scheduled maintenance is located above the reach of the operator, they should follow the companies normal safe practices of reaching that particular height, utilizing the companies specified equipment and following normal safety precautions.

When working with treatment chemicals, operators should always wear protective gloves, safety glasses, and follow the companies safety precautions in the case of any spillage or operator contamination.

**SAFETY WORDS AND SYMBOLS**

It is very important that operators and maintenance personnel understand the words and symbols that are used to communicate safety information. Safety words, their meaning and format, have been standardized for U.S. manufacturers and published by the American National Standards Institute (ANSI). The European Community (E.C.) has adopted a different format based on the International Standards Organization (I.S.O.) and applicable machinery directives. Both formats are presented below. Graphic symbols are not standardized, but most manufacturers will use some variation of the ones seen in this manual.



Indicates an imminently hazardous situation which, if not avoided, **will** result in death or serious injury.



Indicates a potentially hazardous situation which, if not avoided, **could** result in death or serious injury.



Indicates a potentially hazardous situation which, if not avoided, **may** result in minor or moderate injury and/or property damage.



Provides additional information that the operator needs to be aware of to avoid a potentially hazardous situation.



**Mandatory Lockout Power Symbol.** Disconnect, lockout and tag-out electrical and other energy sources before inspecting, cleaning or performing maintenance on this panel.



**International Safety Alert Symbol.** The exclamation point (!) surrounded by a yellow triangle indicates that an injury hazard exists. However, it does not indicate the seriousness of potential injury. The exclamation point (!) is also used with the DANGER, WARNING and CAUTION symbols so the potential injury is indicated.



**Electrocution Hazard Symbol.** This symbol indicates that an electrocution hazard exists. Serious injury or death could result from contacting high voltage.



**International Electrocution Hazard.** This symbol indicates that an electrocution hazard exists. Serious injury or death could result from contacting high voltage.



**Mandatory Read Manual Action Symbol.** (I.S.O. format) This symbol instructs personnel to read the Operators Manual before servicing or operating the equipment.



**Mandatory Read Manual Action Symbol.** This symbol instructs personnel to read the Operators Manual before servicing or operating the equipment.

**NOTICE**

Notice is used to notify people of important installation, operation or maintenance information which is not hazard related.

## **LOCKOUT / TAGOUT PROCEDURES**

Lockout/Tagout is the placement of a lock/tag on an energy isolating device in accordance with an established procedure. When taking equipment out of service to perform maintenance or repair work, always follow the lockout/tagout procedures as outlined in ANSI Z344.1 and/or OSHA Standard 1910.147. This standard “requires employers to establish a program and utilize procedures for affixing appropriate lockout devices or tagout devices to energy isolating devices and to otherwise disable machines or equipment to prevent unexpected energizing, start-up, or release of stored energy in order to prevent injury to employees.”

## **CONTROLLED STOP**

This is the stopping of machine motion by reducing the electrical command signal to 0 (zero) once the stop signal has been recognized.

## **HAZARD REVIEW**



### **Electrocution Hazard**

Electrocution accidents are most likely to occur during maintenance of the electrical system or when working on or near exposed high voltage wiring. This hazard does not exist when the electrical power has been disconnected, properly locked, and tagged out.





**DANGER! RISK OF ELECTRIC SHOCK AND ARC FLASH**

Avoid any alteration to the equipment. Alterations may produce dangerous situations, where serious injury or death may occur. This equipment shall be installed in accordance with local installation codes and applicable regulations which should be carefully followed in all cases. Authorities having jurisdiction should be consulted before installations are made. Owners/operators are responsible for knowing what requirements, hazards, and precautions exist with this equipment. Owners/operators are responsible for informing all personnel associated with the equipment and all who are in the general area of the equipment, the requirements, hazards, and precautions that exist with this equipment. Electrical equipment should be installed, operated, serviced, and maintained only by qualified personnel. A qualified person is one who has skills and knowledge related to the construction and operation of electrical equipment and its installation and has received safety training to recognize and avoid the hazards involved. Only appropriately trained persons who are familiar with and understand the contents of this manual and all other pertinent product documentation are authorized to work on and/or with this product. Owners/operators must ensure that all authorized persons have sufficient technical training, knowledge, and experience and be able to foresee and detect potential hazards that may be caused by using the product, by changing the settings and by the mechanical, electrical, and electronic equipment of the entire system in which the product is used. All persons working on and with the product must be fully familiar with all applicable standards, directives, and accident prevention regulations when performing such work. Servicing and maintaining the equipment should only occur if the equipment is deenergized and properly locked out and tagged out. If it is unfeasible to service or maintain the equipment while deenergized, the following standards shall be referenced to ensure safe practices are being followed and proper PPE is being used: 29 CFR § 1910.333 and 29 CFR § 1910.137. No responsibility is assumed by USC, LLC for any consequences arising out of the use of this material.



## HUB SYSTEM

**YOU** are responsible for the **SAFE** operation and maintenance of your USC, LLC equipment . **YOU** must ensure that you and anyone else who is going to operate, maintain or work around the equipment be familiar with the operating and maintenance procedures and related **SAFETY** information contained in this manual. This manual will take you step-by-step through your working day and alert you to good safety practices that should be adhered to while operating the equipment

Remember, **YOU** are the key to safety. Good safety practices not only protect you, but also the people around you. Make these practices a working part of your safety program. Be certain that **EVERYONE** operating this equipment is familiar with the recommended operating and maintenance procedures and follows all the safety precautions. Most accidents can be prevented. Do not risk injury or death by ignoring good safety practices.

- Equipment owners must give operating instructions to operators or employees before allowing them to operate the machine, and at least annually thereafter per OSHA (Occupational Safety and Health Administration) regulation 1928.57.
- The most important safety device on this equipment is a **SAFE** operator. It is the operator's responsibility to read and understand **ALL** Safety and Operating instructions in the manual and to follow them. All accidents can be avoided.
- A person who has not read and understood all operating and safety instructions is not qualified to operate the machine. An untrained operator exposes himself and bystanders to possible serious injury or death.
- Do not modify the equipment in any way. Unauthorized modification may impair the function and/or safety and could affect the life of the equipment.
- Think SAFETY! Work SAFELY!

### GENERAL SAFETY

1. Only trained persons shall operate the equipment . An untrained operator is not qualified to operate the machine.
2. Have a first-aid kit available for use should the need arise, and know how to use it.
3. Provide a fire extinguisher for use in case of an accident. Store in a highly visible place.
4. Do not allow children, spectators or bystanders within hazard area of machine.





## HUB SYSTEM

5. Wear appropriate protective gear. This includes but is not limited to:

- A hard hat
- Protective shoes with slip resistant soles
- Protective goggles
- Heavy gloves
- Hearing protection
- Respirator or filter mask



6. Place all controls in neutral or off, stop motor, and wait for all moving parts to stop. Then disable power source before servicing, adjusting, repairing, or unplugging.



7. Review safety related items annually with all personnel who will be operating or maintaining the equipment.

### **OPERATING SAFETY:**

1. Read and understand the operator's manual and all safety signs before using.
2. Disconnect and disable electrical supply completely and wait for all moving parts to stop before servicing, adjusting, repairing or unplugging.
3. Clear the area of bystanders, especially children, before starting.
4. Be familiar with the machine hazard area. If anyone enters hazard area, shut down machine immediately. Clear the area before restarting.
5. Keep hands, feet, hair and clothing away from all moving and/or rotating parts.
6. Stay away from overhead obstructions and power lines during operation and transporting. Electrocutation can occur without direct contact.
7. Do not operate machine when any guards are removed.
8. Inspect welds and repair if needed.

## HUB SYSTEM



Before placement of the equipment, be sure that ground is reasonably level. The equipment may topple or work improperly if the ground is too uneven, damaging the equipment and/or causing personal injury.

### PLACEMENT SAFETY

1. Move only with the appropriate equipment
2. Stay away from overhead power lines when moving the equipment. Electrocutation can occur without direct contact.
3. Be familiar with machine hazard area. If anyone enters hazard areas, shut down machine immediately. Clear the area before restarting.
4. Place on a level surface.

### MAINTENANCE SAFETY

1. Review the operator's manual and all safety items before working with, maintaining or operating the equipment.
2. Place all controls in neutral or off, stop motors, disable power source, and wait for all moving parts to stop before servicing, adjusting, repairing or unplugging.
3. Follow good shop practices:
  - Keep service area clean and dry.
  - Be sure electrical outlets and tools are properly grounded.
  - Use adequate light for the job at hand.
4. Keep hands, feet, hair and clothing away from all moving and/or rotating parts.
5. Clear the area of bystanders, especially children, when carrying out any maintenance and repairs or making any adjustments.
6. Before resuming work, install and secure all guards when maintenance work is completed.
7. Keep safety signs clean. Replace any sign that is damaged or not clearly visible.



## HUB SYSTEM

### **SAFETY LABELS**

1. Keep safety labels clean and legible at all times.
2. Replace safety labels that are missing or have become illegible.
3. Replaced parts that displayed a safety label should also display the current label.
4. Replacement safety labels are available. Contact your authorized dealer.

#### **How to Install Safety Labels:**

- Be sure that the installation area is clean and dry.
- Be sure temperature is above 50°F (10°C).
- Decide on the exact position before you remove the backing paper.
- Remove the smallest portion of the split backing paper.
- Align the sign over the specified area and carefully press the small portion with the exposed sticky backing in place.
- Slowly peel back the remaining paper and carefully smooth the remaining portion of the sign in place.
- Small air pockets can be pierced with a pin and smoothed out using the piece of sign backing paper.



Located on the USC equipment you will find safety labels.  
Always be sure to read and follow all directions on the labels.

HUB SYSTEM

Think **SAFETY!** Work **SAFELY!**

REMEMBER—If Safety Labels have been damaged, removed, become illegible, or parts replaced without safety labels, new labels must be applied. New safety labels are available from your authorized dealer



Part # 09-02-0001



Part # 09-02-0010



**INSTALLATION** SECTION B

**HIGH VOLTAGE** ~ Always disconnect the power source before working on or near the control panel or lead wires.



**HIGH VOLTAGE** ~ Use insulated tools when making adjustments while the controls are under power.



The batching system must be installed on a solid level surface, free from vibration, wind, or anything which may jar the scale.



Read and follow Material Safety Sheets that come with the chemicals being mixed.

**KEG TRANSFER PUMP INSTALLATION**

1. Place the HUB System in the desired location.
2. Place keg transfer pumps in the desired positions near the right side of the unit. As close as possible to keep hoses short.
3. Connect the output line from the pumps, using the cam-lock fitting on the pump hose to the cam-lock on the adapter.
4. Connect the yellow end of the adapter to the connectors on the right side of the unit. Each pump must be connected to the same numbered connectors on the end of the unit (pump output) and on the bottom of the control panel (pump electrical control).
5. Connect adapter to end on power cord on pump. Connects to item 16 on page 14 .

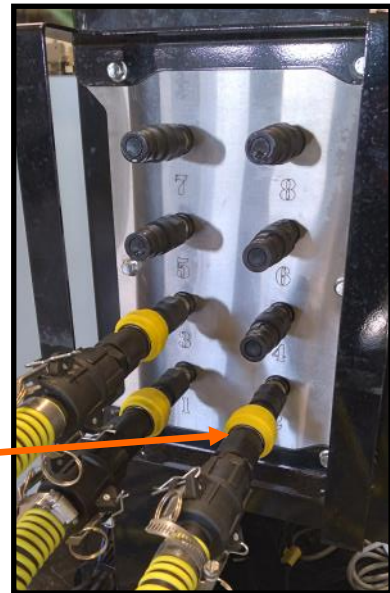

## HUB SYSTEM

### ELECTICAL CONNECTIONS

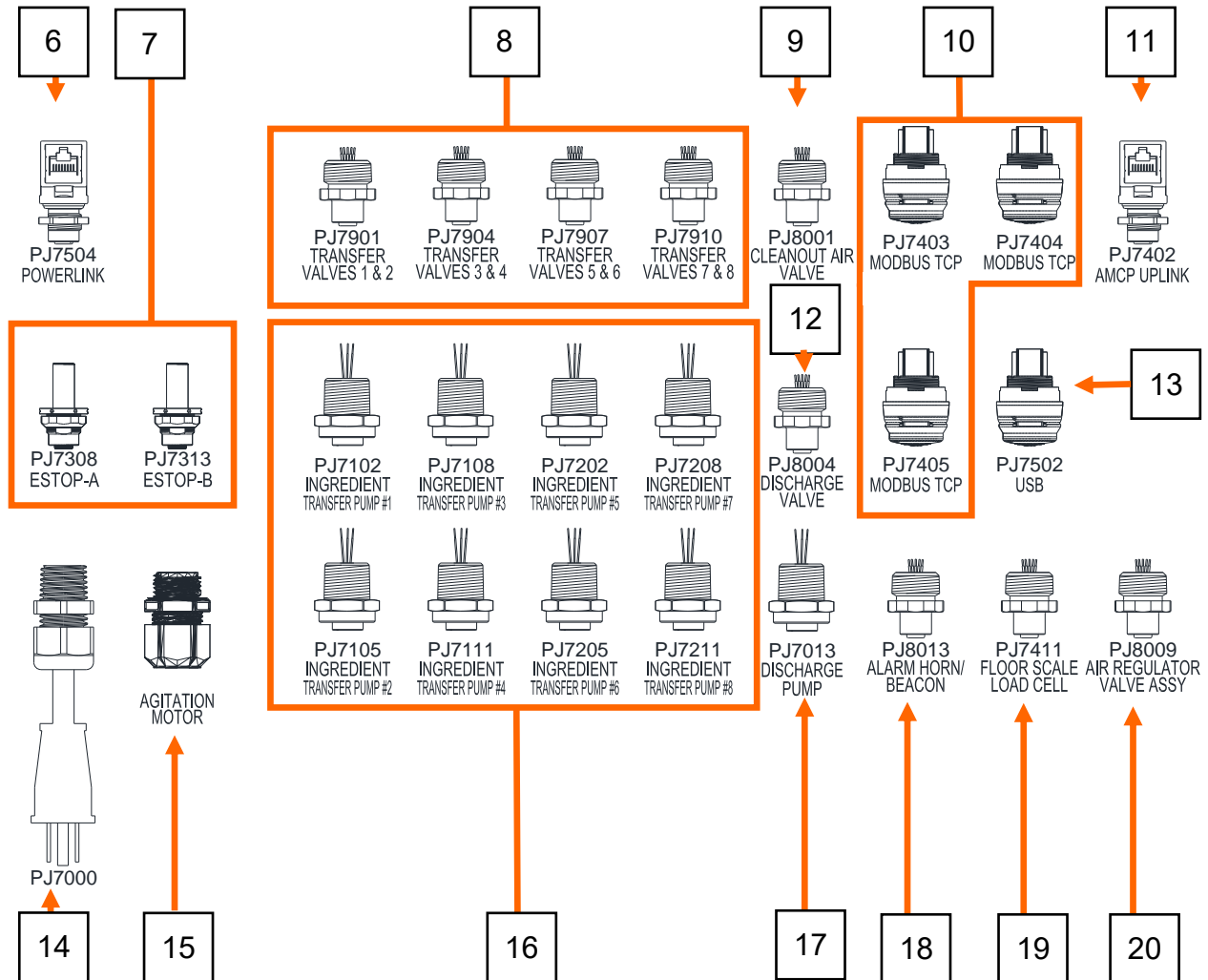

6. This port is only used to interconnect between the two control panels when there are more than 8 pumps being controlled.
7. Connect the red cable to the PJESTOPA on the Main Control Panel (MCP) and then to the PJESTOPB on the next panel that is closest to the MCP. Repeat this process until all control panels are connected in a daisy chain configuration. It may be MCP to Treater to Tri-Flo® to Bin Site panel. The order or number of devices is not important. It is important that each cable is ran from an A connection to a B connection (never A to A or B to B), and that no control panel is left out of the chain. Connect the two red plugs onto each of the remaining open PJESTOP connectors on the first and last panel.
8. Factory connected to the valves on top of the mix tank.

## HUB SYSTEM

9. Factory connected to the cleanout air valve.
10. There are three MODBUS TCP Ethernet connectors on the Control Panel. These are used for connecting scale heads, printers, wireless access port, etc.
11. Field connect to port, AMPC UPLINK, on the Main Control Panel. This is a teal colored cable.
12. Factory connected to the discharge valve
13. Insert USB drive to upload and download information.
14. Main power cable, connect to 120 volt / 1 phase grounded power.
15. Factory connected to the agitation motor.
16. Field connect the adapter cable from each pump to these terminals. Note: the number on the pump power connection corresponds to the number on the side panel used to connect the pump liquid output.
17. Factory connected to the discharge pump.
18. Factory connected to the alarm horn / beacon.
19. Factory connected to the scale load cell.
20. Factory connected to the air regulator assembly.
21. Remove the scale shipping brackets and store for future use. These must be reinstalled anytime the system is being moved or the scale could be damaged.

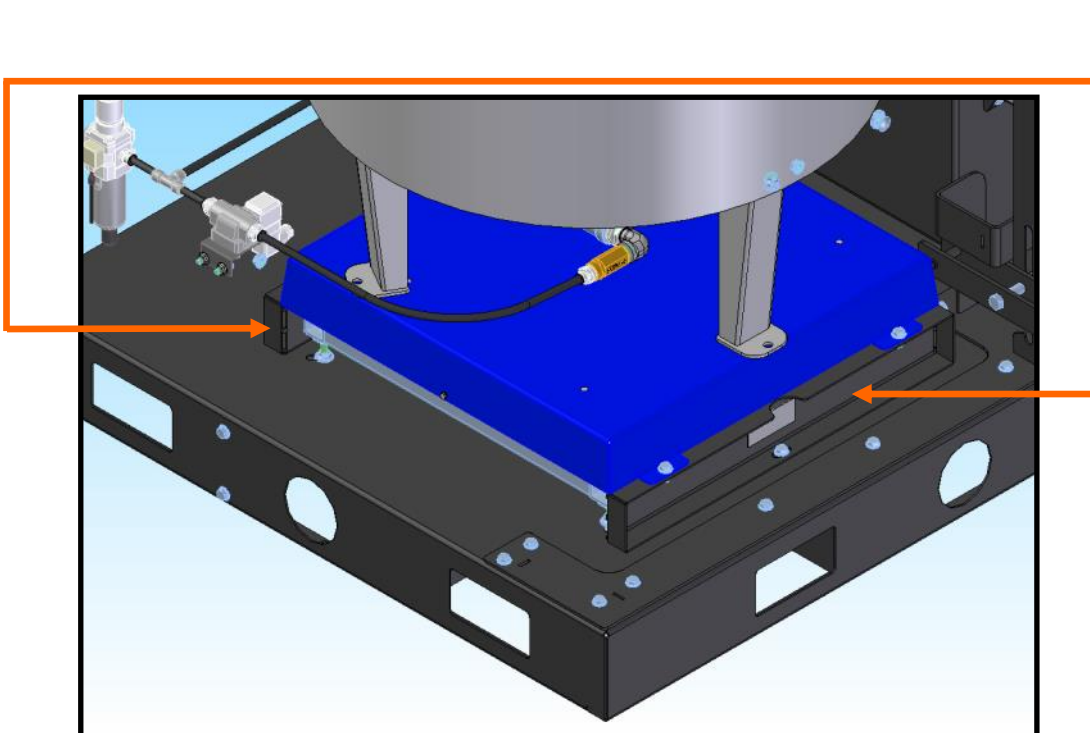



## HUB SYSTEM

22. Supply approximately 100 - 120 pounds of air pressure from the dryer to the port .It is required that the air supply have an in-line customer supplied air dryer to protect the air system from contamination.
23. Remove one of the bulkhead fittings from the treater pump stand.
24. Install bulkhead (2) fitting that comes with the unit.
25. Install the 90 degree hose barb (3) into the bulkhead fitting.

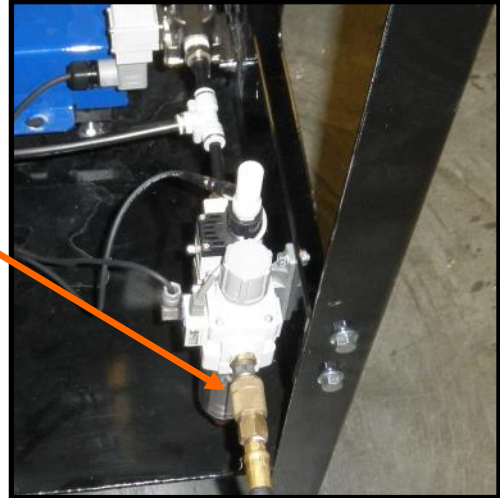

### NOTICE

When pumping chemical into this tank, keep the lid closed to prevent splashing at end of run.

26. Attach the wire reinforced 3/4 inch hose end (1) to the hose barb (3)and secure with hose clamp (4).
27. Attach other end of wire reinforced 3/4 inch hose (1) to the output pump and secure with hose clamp (4)

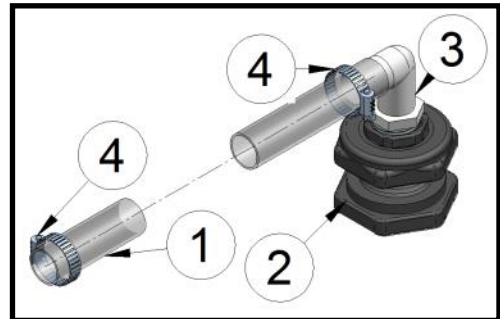

Steps 24-26

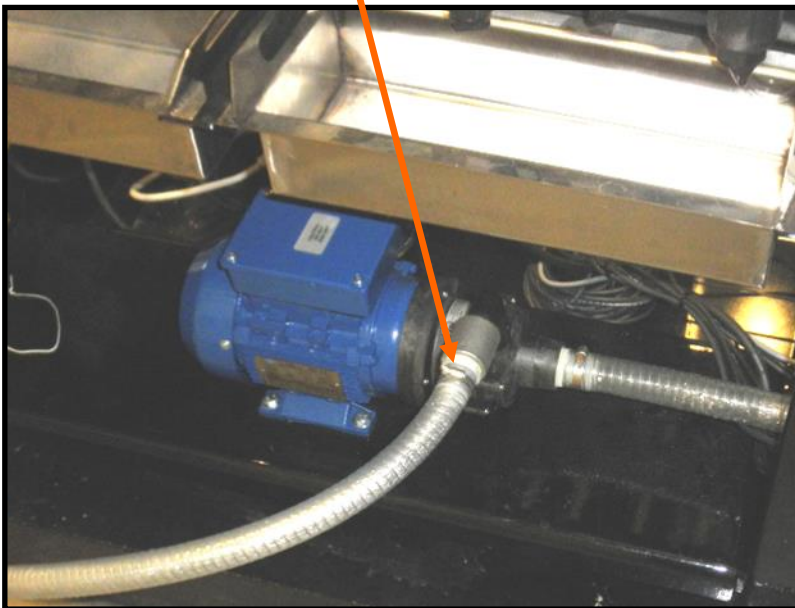

## SCALE OPERATION AND CALIBRATION

	<b><u>ELECTROCUTION HAZARD</u></b>
	Extra caution must be exercised when working inside the control panel when it is powered.
	<b><u>DANGEROUS VOLTAGES ARE PRESENT</u></b>

The scale calibration needs to be checked periodically (daily, after moving the system). Use the steps below for load cell calibration.

1. Check the tank to make sure that it is empty and nothing is binding on it.
2. Place the a known weight (about 50 lbs.) on the top of the tank.
3. Go to the HOA screen on the control panel.
4. If the screen shows the correct weight, remove the weight and store. If the screen does not show the correct weight, remove the weight and go to step 5 and re-calibrate the load cell.
5. With the control panel powered, unlock and open the door.
6. With the screw removed to gain access to the calibration switch, apply power to the 201 Weight Transmitter.
7. Press and hold the calibration switch through the opening from the removal of the screw in the prior step for approximately 2 seconds until the display changes to Set-up. This is best done with a small tool.(e.g. a 3/32 or 2mm Hex Key Wrench or small screwdriver.)



Face of unit

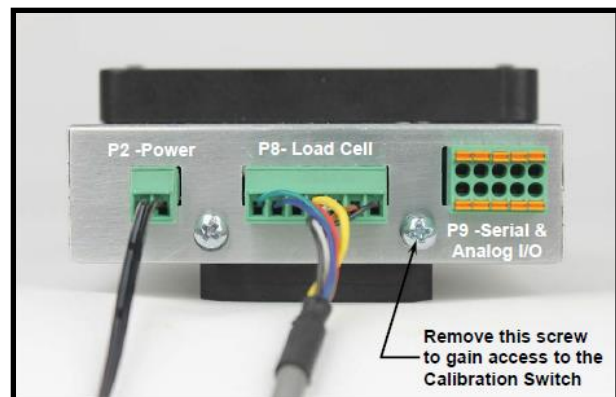

Step 6

## HUB SYSTEM

8. Release the calibration switch to begin setup.
9. Press the F2/▲ key to step until the display shows CAL.
10. With CAL = displayed, press the F3/← key. The display will change to CAL=. Proceed to the CAL= (Perform Calibration) parameter.
11. With CAL= displayed, press the F3/← key. The display will change to no.
12. Press the F2/▲ key to toggle to YES and then press the F3/← key. The display will change to CAL 1=. Proceed to the CAL 1= parameter.
13. The display will show CAL 1 =. This is the first of two calibration weights. This weight is ZERO (NO LOAD).
14. Press the F3/← key to view the current setting.
15. Press the F3/← key again to set absolute zero.
16. Starting at the left and proceeding right, a series of dashes will appear and then disappear. Then the display will show CAL 2=.
17. This is the second of two calibration weights . This weight is with the known test weight.
18. Press the F3/← key to view the current setting.
19. Use the F1/◀ and F2/▲ to input the value of the test weight. The display must read the same as the known weight.
20. Place Weight on the tank, wait for the tank to stop moving, then press the F3/← key.
21. Starting at the left and proceeding right, a series of dashes will appear and then disappear. Then the display will show F SPAn.
22. The calibration process is now complete. Press F1/◀ until you are returned to the starting screen.
23. Replace the screw removed in step 7.
24. Close and lock the control panel.
25. Remove and store the weight .

## HUB SYSTEM

### **CUSTOMER SUPPLIED PUMP SPECIFICATIONS**

If the customer is supplying their own pumps, they must meet the following requirements:

1. Voltage: 120 VAC, 2.5 amps
2. Integrated thermal overload protection
3. 13 Gallon per minute pump.
4. 1" Camlock female connector to 1/2 inch Parker female coupling.
5. Standard 3 prong 120 volt male plug.

SECTION C **ELECTRICAL AND AUTOMATION**



**HIGH VOLTAGE** ~ Always disconnect the power source before working on or near the control panel or lead wires.



**HIGH VOLTAGE** ~ Use insulated tools when making adjustments while the controls are under power.



**AUTHORIZED PERSONNEL** only shall work on the control panel. Never allow anyone who has not read and familiarized themselves with the owner's manual to open or work on the control panels.

This section provides a general overview and description of the operator control panels for the HUB SYSTEM.



**USC recommends the use of a surge protection device with a minimum rating of 400 Joules for all automated main control panels.**



Any disturbance of the tank while chemical is being measured (wind, vibration, bumping, or other contact) will cause inaccurate measurement of the incoming chemical.

# HUB SYSTEM MAIN SCREEN

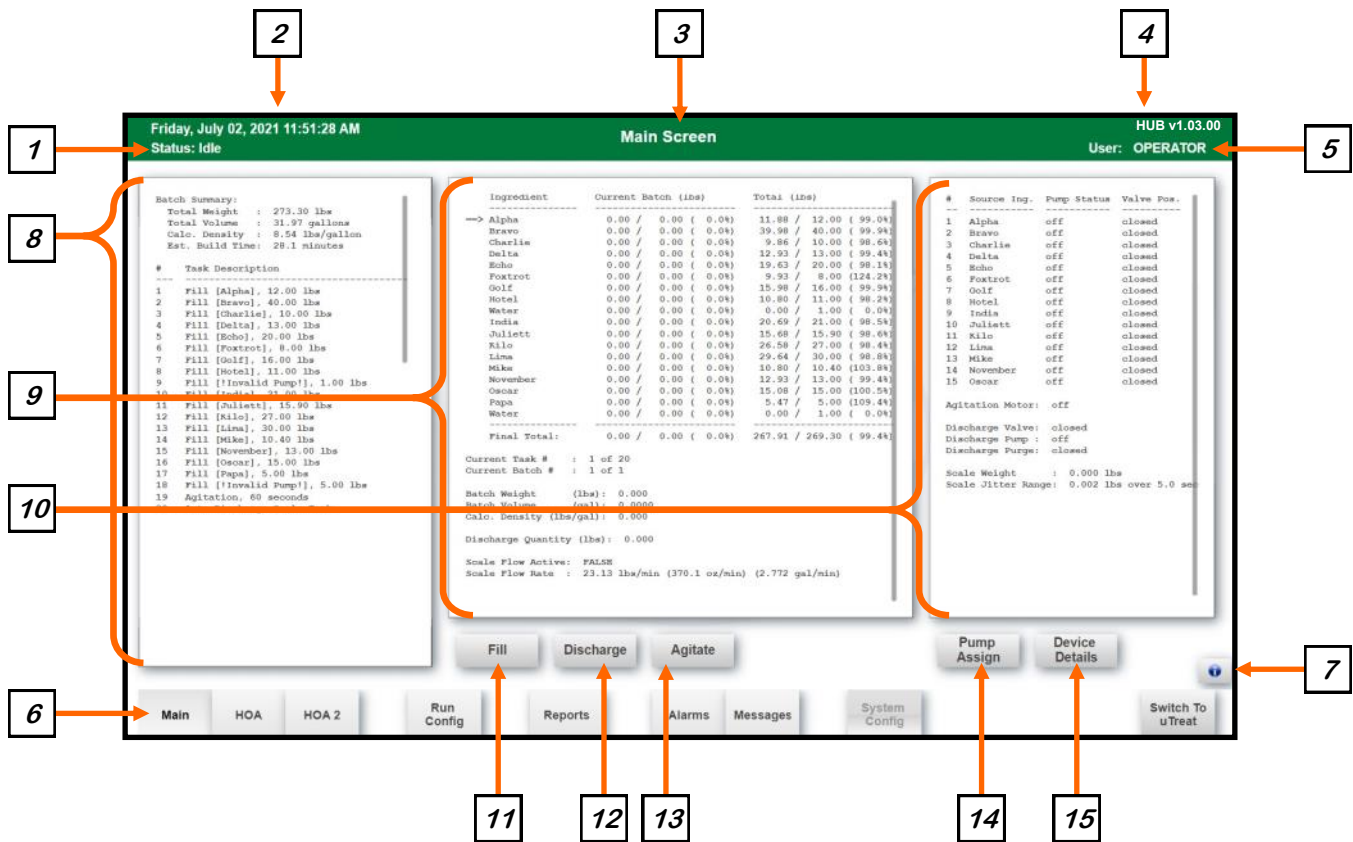

**1. SYSTEM STATUS DISPLAY:** Displays the current state of the automated process. If the system is not in operation it will read **Idle**. While in operation, the status will detail the current process step in the weightment process.

**2. DATE AND TIME DISPLAY:** Displays the current date and time. Pressing this will display the Date and Time edit interface. (Shown Right) Here you can swipe up or down on each column to set the correct date and time. Press Enter to accept the entered date and time. Press Reset to reset any modifications made.

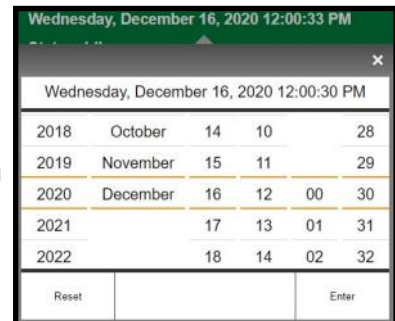

**3. SCREEN TITLE DISPLAY:** Displays the current screen title for the page the user is viewing.

**4. PROGRAM VERSION DISPLAY:** Displays the current program version of the automation. This will also display the Sales Order number if used.

**MAIN SCREEN (Continued..)**

**5. USER DISPLAY:** Displays the currently logged in User. Pressing this button will display the Login Interface. (Shown Right) Pressing to the right of Username or Password will bring up a keyboard (Shown Below). Type **OPERATOR** into the Username field and type **USC** into the Password field. The Username and Passwords are case sensitive.



Pressing Login will allow you to login as a level one user and allow control of standard operations. Higher login credentials will allow the user to enter the System Config screen to modify the system configuration.

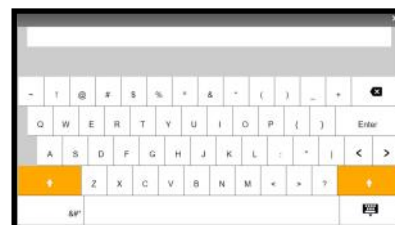
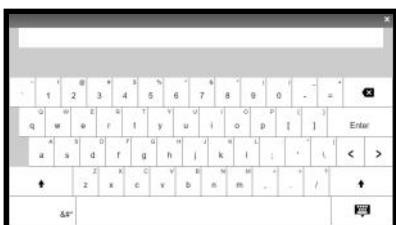

By pressing the up arrow once, the next character typed will be uppercased. By pressing the up arrow twice, all the following characters will be uppercased until the arrow is pressed again.

**6. NAVIGATION BUTTON BAR:** Pressing these buttons will take the user to the selected screen. Some buttons may be greyed out if the correct user is not logged in.



While an alarm is currently active on the system the Alarms button will appear red in color. Once all alarms are resolved, the button return to the default color.

**7. TOOLTIP DISPLAY BUTTON:**  Pressing this button will present tooltip help for objects on the screen. The tooltip display button will be present on many other screens.

**8. TASK LIST DISPLAY:** Displays the task list for the currently defined process. Included in this list is a Summary section which shows the requested Total Weight, Total Volume, Calculated Density, and an estimated build time of the batch. If the estimated build time has an ‘\*’ by the value, some manual operation is needed and the estimated time may be inaccurate. Below the Summary section is the individual task items for the requested process. The process will start with the first item and work its way down the list. The items could be the following. Fill, Hand-Add, Agitation (if present and used), Auto Discharge (if used), or Manual Discharge. Swiping up or down on this list will allow the user to view all items in the current process.



## HUB SYSTEM

### MAIN SCREEN (Continued..)

**9. RUN INFO DISPLAY:** Displays the run information for the currently active process.

The Ingredient section details each ingredient used. A '==>' indicator will show by the currently processing ingredient. Under the Current Batch the amounts requested for this tank are displayed. The active amount is displayed on the left, the target amount is displayed in the center, and the percent fill is displayed on the right. The Total section will display the totals across multiple batches if the requested amount cannot be contained within the scale tank. The Final Total will display the total combined of the tank fill or batch.

Ingredient	Current Batch (lbs)	Total (lbs)
Alpha	50.37 / 50.68 (99.3%)	50.37 / 50.68 (99.3%)
Delta	73.56 / 73.87 (99.5%)	73.56 / 73.87 (99.5%)
Golf	116.25 / 116.62 (99.6%)	116.25 / 116.62 (99.6%)
India	141.67 / 142.03 (99.7%)	141.67 / 142.03 (99.7%)
==> November	14.10 / 115.54 (12.2%)	0.00 / 0.00 (0.0%)
Final Total:	395.98 / 498.76 (79.3%)	381.88 / 381.21 (99.6%)

Current Task # : 5 of 5  
Current Batch # : 1 of 1

Batch Weight (lbs): 395.981  
Batch Volume (gall): 43.6569  
Calc. Density (lbs/gall): 9.070

Discharge Quantity (lbs): 0.000

Scale Flow Active: TRUE  
Scale Flow Rate : 33.47 lbs/min (835.6 oz/min) (3.686 gal/min)

Below the table the Current Task and Current Batch can be found. This will tell the user where in the process the system is. The Batch Weight, Batch Volume, and Calculated Density is displayed below. These are representations of what is currently in the tank. If discharge is used in the process, the Discharge Quantity will display the amount discharged. Lastly a Scale Flow Active status is displayed to inform whether the system believes flow is active. While filling or discharging the Scale Flow Rate can be observed as pounds per minute, weighted ounces per minute, and gallons per minute.

**10. DEVICE DETAILS DISPLAY:** Displays the details of current active devices, such as what ingredients are attached to what pump. Also shown is the pump ON/OFF motor status and corresponding valve status. Below you can find the motor status for the Agitation motor (if present), Discharge Pump, Discharge Valve, and the Discharge Air Purge (if the discharge feature is enabled). Last you can view the current Scale Weight. The Scale Jitter Range will display the amount of scale fluctuation detected over a 5 second period.

#	Source Ing.	Pump Status	Valve Pos.
1	Alpha	off	closed
2	Bravo	off	closed
3	Charlie	off	closed
4	Delta	off	closed
5	Echo	off	closed
6	Foxtrot	off	closed
7	Golf	off	closed
8	Hotel	off	closed
9	India	off	closed
10	Juliett	off	closed
11	Kilo	off	closed
12	Lima	off	closed
13	Mike	off	closed
14	November	*RUNNING*	*OPEN*
15	Oscar	off	closed
16	Papa	off	closed

Agitation Motor: off

Discharge Valve: closed  
Discharge Pump : off  
Discharge Purge: closed

Scale Weight : 395.982 lbs  
Scale Jitter Range: 2.780 lbs over 5.0 sec

## HUB SYSTEM

### MAIN SCREEN (Continued..)

**11. FILL SETUP BUTTON:** Pressing this button will display the Fill Setup dialog (See Below). Here the user can define a fill recipe. To define a fill recipe the user will either type an Ingredient Name or press Ingredient Lookup and select an ingredient that is assigned to a pump. The order of the list will determine the order to fill. Pressing Clear will clear a line item from the recipe. When the Ingredient Lookup button is pressed a selection list will pop up and display all of the ingredients that are currently available on the pumps. Upon selection, the Density will pre-populate with the density found from the Pump Assign screen. If a typed-in ingredient is not recognized, the Density will need to be typed in manually. Below the list is a drop down list button to allow the user to target by Ingredient Weight, by Ingredient Application Rate (Seed Weight in pounds or by SCU), or by Ingredient Percent of Gallons. Depending on which targeting method is used, the Target field will have different units. When in Application Rate mode, each ingredient will allow indicating oz/cwt or oz/SCU. If no SCU options are selected, the SCU-related seed metrics will disappear. If the ingredient is meant to be added in by hand, then the Hand Add check box should be selected.

If your system is not configured with a discharge system, you will instead have a floor scale and an option available called Fill Count. This allows for several containers to be placed on the scale and one filled right after the other during the same run. Fill Count tells the system how many containers need filled. The system will pause at the end of filling each container so that you may connect the next container and then tell the system to continue. The containers will be filled equally in this mode.

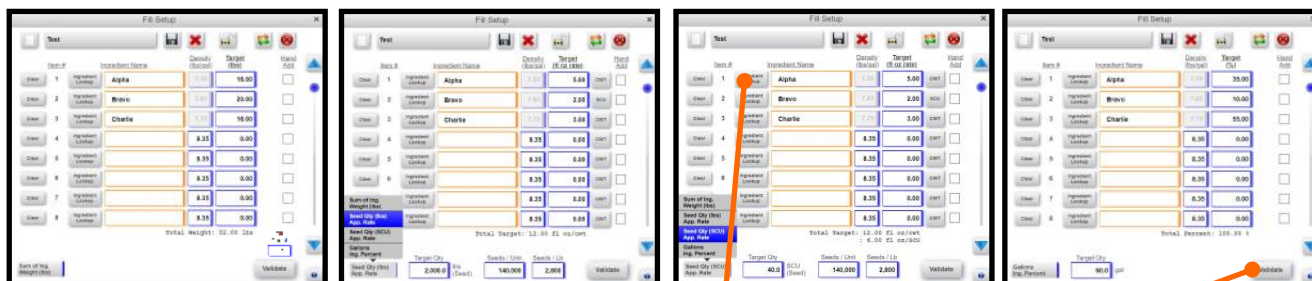

Once the recipe is built to satisfaction the Validate button can be pressed. This will bring up the Validation popup. (See Right) Here the user can review the recipe that was created on the Fill Setup screen. This list is the Task List. The process will start from the top and process items one at a time. The Task Name will depict what a task item will be doing. If a single task item should need to be added by hand, then the Hand Add Item should be selected. If there is an task item that has an issue or is invalid, a brief description can be found under the Valid Check column. The user can also scroll through the list by utilizing the navigation button on the right. At the bottom of the Validation popup a Batch Summary can be found to display run statistics for the built run. Once all items have been validated, the Start Fill button can be pressed to begin the automated process of filling.

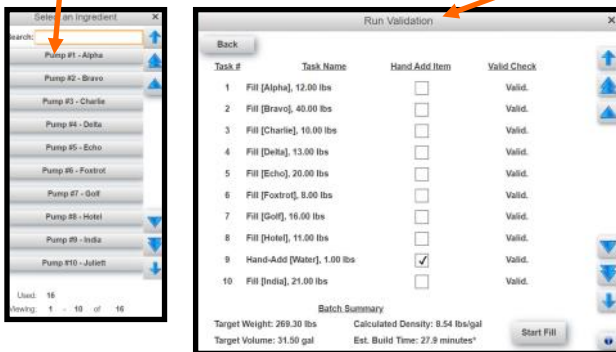

## HUB SYSTEM

### MAIN SCREEN (Continued..)

The row of objects at the top of the Fill screen will be visible if Recipe Mode has been enabled in the System Config screen. This mode allows for managing saved recipes.

From left to right, the first object at the top is New Recipe, then Recipe Name and Selection, Save Record, Delete Record, Lock Record, Import/Export and Delete Database. The last two objects on the right are only visible to administrators. The Lock Record button is only operable by administrators.



When the Save button is used, an additional popup will occur which gives you the opportunity to provide a name for the recipe. It will inform you of any naming conflicts, etc., and keep you from saving your recipe until they're handled. It also offers a New Record checkbox. If you wish to save a copy of an existing record, check New Record, then assign a new unique name, then hit Save. If you are working with an already saved record and you wish to rename it, simply make sure New Record is unchecked and then assign a new unique name and hit Save.

When the record is set to Locked, the Save Record and Delete Record buttons will disappear. All recipe editing fields will also become locked except for the seed profile parameters at the bottom of the window. If a locked record needs a Hand Add status changed, that can still be done later on the Validation screen.

The Import/Export button will prompt you about which of the two functions you'd like to perform.

The Delete Database button will prompt you with a Yes/No selection to make sure you really want to delete the entire Recipe database.

**12. DISCHARGE BUTTON:** This button is only present if the discharge feature is enabled. Pressing this button will display the Discharge dialog. Here the user can choose to discharge the blend within the tank using the automated discharge process. Pressing Empty will start the discharge process. The discharge valve will open and the discharge pump will turn on. Once the tank is empty, the discharge pump will turn off and the valve will close. Then the discharge air purge will activate for a time. If the user wishes to end the discharge process early, they press the Finish button. A report is created detailing the amount discharged.



**13. AGITATE BUTTON:** This button is only present if an agitation motor is present. Pressing this button will display the Agitation dialog. Here the user can agitate the blend tank for a specified amount of time. Pressing Auto Agitate will turn the agitation motor on for the specified amount of time. Pressing Finish will end the auto agitation early.



HUB SYSTEM

**MAIN SCREEN (Continued..)**

**14. PUMP ASSIGN BUTTON:** Pressing this button will display the Pump Ingredient Assignment dialog. Here Ingredients can be assigned to a pump for use in the process. Pressing the Clear button will clear the ingredient from the pump. Pressing Ingredient Lookup will allow the user to select from a previously used list of ingredients. Please note that only one ingredient name at a time can be used between all pumps. To add a new Ingredient to the system select the box under Ingredient Name. A keyboard will pop up allowing the user to name the new ingredient. After an ingredient is created, the Density can be adjusted. Adjusting the Pulse Time adjusts the valve open time while performing the pulsing operation. The Calibrated check box denotes that the current ingredient for that pump has been calibrated by the system. The system will automatically check this once a successful calibration has occurred. If the user wishes to perform the calibration again, simply uncheck the check box and the calibration will occur during the next run. If Pumps 9-16 are connected to the system, the Pumps 9-16 button will become visible. If pressed, the user can assign ingredients to pumps 9-16.

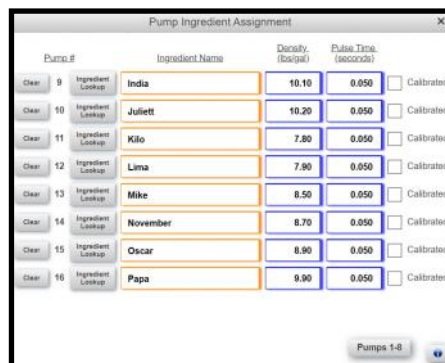

**15. DEVICE DETAILS BUTTON:** Pressing this button will display the additional Device Details dialog. Here more details can be seen for the ingredient attached to a pump. These extra details are the Density, Flow Rate, Pulse Weight, Pulse Time, Calibrated, and the Stream Pre-Act time.

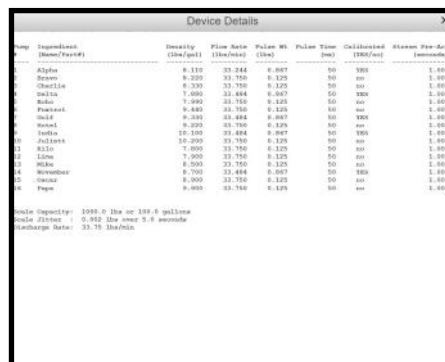

During each run the Flow Rate is calculated. This is the rate of flow from the pump onto the scale tank.

Once the system has had an opportunity to process enough of a ingredient, the Pulse Weight can be calculated. The Pulse Weight is the amount of weight gained during one pulse. This process will require at least 8 pounds of ingredient to be weighed. Once this value is calculated the Calibrated flag will change from no to YES.

After each weighment that is not being calibrated, the Stream Pre-Act value is calculated. This value is used to calculated how soon before the requested amount is reached to begin final pulsing.

## HUB SYSTEM HOA SCREEN



**1. AUTO ALL DEVICES BUTTON:** Pressing this button will place all devices in the Auto mode of operation.

**2. ZERO SCALE BUTTON:** Pressing this button will zero the scale weight once the motion is not detected on the scale. This process may take some time.

**3. SCALE WEIGHT DISPLAY:** Displays the current scale weight in pounds.

**4. TOOLTIP DISPLAY BUTTON:**  Pressing this button will present tooltip help for objects on the screen.

**5. INGREDIENT PUMP CONTROL MODULES:** The HAND button will place the pumps in the manual mode of operation. The OFF button will place the pumps in the off mode of operation. The AUTO button will place the pumps in the automatic mode of operation. The motor will not operate in this mode unless initiated by the system during an automated process. Only 1 pump can be active at a time.

**6. INGREDIENT VALVE CONTROL MODULES:** The OPEN button will place the valves in the open position. The CLOSE button will place the valves in the close position. The AUTO button will place the valves in the automatic mode of operation. The valves will not operate in this mode unless initiated by the system during an automated process.



**HOA SCREEN (Continued..)**

**7. DISCHARGE PUMP CONTROL MODULE:** The HAND button will place the pump in the manual mode of operation. The OFF button will place the pump in the off mode of operation. The AUTO button will place the pump in the automatic mode of operation. The motor will not operate in this mode unless initiated by the system during an automated process. Only 1 pump can be active at a time.

**8. AGITATION MOTOR CONTROL MODULE:** The HAND button will place the agitation motor in the manual mode of operation. The OFF button will place the agitation motor in the off mode of operation. The AUTO button will place the agitation motor in the automatic mode of operation. The motor will not operate in this mode unless initiated by the system during an automated process. This module will only be visible if the agitation motor is present.

**9. DISCHARGE VALVE CONTROL MODULE:** The OPEN button will place the valve in the open position. The CLOSE button will place the valve in the close position. The AUTO button will place the valve in the automatic mode of operation. The valve will not operate in this mode unless initiated by the system during an automated process. This will only be visible if the discharge feature is enabled.

**10. AIR PURGE CONTROL MODULE:** The HAND button will place the air purge in the manual mode of operation. The OFF button will place the air purge in the off mode of operation. The AUTO button will place the air purge in the automatic mode of operation. The air purge will not operate in this mode unless initiated by the system during an automated process. The discharge valve must be closed for the device to function. This will only be visible if the discharge feature is enabled.

**RUN CONFIGURATION SCREEN**



**1. TOOLTIP DISPLAY BUTTON:**  Pressing this button will present tooltip help for objects on the screen.

**2. EXTRA QUANTITY INPUT:** Pressing this box will present a keypad to enter a numeric value. This value is the extra quantity of gallons to increase or decrease the requested batch fill by.

**3. AUTO DISCHARGE BATCH:** Pressing this check box will enable/disable auto discharging after a batch fill is complete. While enabled the system will add a task to discharge once filling is complete. While disabled the system will not discharge automatically and will require a manual discharge to continue. This will only be visible if the discharge feature is enabled.

**3. AUTO AGITATE BATCH:** Pressing this check box will enable/disable auto agitation after a batch fill is complete. While enabled the system will add a task to agitate once filling is complete. While disabled the system will not agitate. This option is only visible if the agitation motor is present.

**5. AUTO AGITATE TIME INPUT:** Pressing this box will present a keypad to enter a numeric value. This value is the agitation time in seconds to agitate after a fill is complete. This option is only visible if the agitation motor is present.



## HUB SYSTEM REPORT SCREEN

The screenshot shows a report interface with the following elements:

- 4:** Start Time: 2021/03/10 08:11:26
- 5:** End Time: 2021/03/10 08:20:45
- 6:** Paused: NO
- 7:** Alarmed: NO
- 8:** Ingredient table with columns: Ingredient, Density (lbs/gal), Current Batch (lbs), Hand Add, and Calibrated.
- 9:** Batch Weight: 227.237 lbs
- 10:** Batch Volume: 25.5610 gallons
- 11:** Batch Density: 8.889 lbs/gal
- 12:** Discharge Weight: 227.237 lbs
- 1:** Tooltip display button (question mark icon)
- 2:** Delete Reports button
- 3:** Export Reports button

Ingredient	Density (lbs/gal)	Current Batch (lbs)	Hand Add	Calibrated
Alpha	10.150	15.03 / 15.00 (100.2%)	NO	YES
Bravo	9.450	14.04 / 14.00 (100.2%)	NO	YES
Charlie	7.200	14.59 / 14.65 (99.6%)	NO	YES
Delta	9.560	10.05 / 10.00 (100.5%)	NO	YES
Echo	8.345	15.97 / 16.00 (99.8%)	NO	YES
Foxtrot	9.220	15.29 / 15.30 (99.9%)	NO	YES
Golf	9.700	11.98 / 12.00 (99.8%)	NO	YES
Hotel	13.200	9.24 / 9.30 (100.5%)	NO	YES
Water	8.345	0.00 / 5.00 ( 0.0%)	YES	NO
Hotel	13.200	13.17 / 13.24 (99.4%)	NO	YES
India	8.345	12.93 / 13.00 (99.5%)	NO	YES
Juliett	8.345	15.02 / 15.00 (100.1%)	NO	YES
Kilo	8.345	14.46 / 14.35 (100.8%)	NO	YES
Lima	8.345	8.70 / 8.00 (98.7%)	NO	YES
Mike	8.345	16.95 / 16.98 (99.8%)	NO	YES
November	8.345	17.22 / 17.20 (100.1%)	NO	YES
Oscar	8.345	11.28 / 11.25 (100.2%)	NO	YES
Papa	8.345	11.15 / 11.08 (100.6%)	NO	YES
Final Total:		227.23 / 232.36 (97.8%)		

**1. TOOL TIP DISPLAY BUTTON:** Pressing this button will present tooltip help for objects on the screen.

**2. DELETE REPORTS BUTTON:** Pressing this button will pop up a prompt for the user to delete reports. (Shown Right)

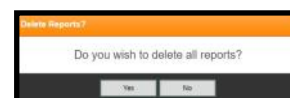

**3. EXPORT REPORTS BUTTON:** Pressing this button will pop up a prompt for the user to export reports. (Shown Right) This button is only enabled when a USB is connected.

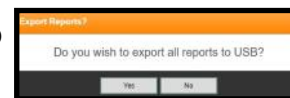

**4. REPORT SELECTION BUTTON:** Pressing this button will pop up a selection list of reports to select from. (Shown Right) Reports are sorted by the date the run started. If a requested process required multiple batches to complete, all reports for that requested process will be listed with the same selection name.



**5. START AND END TIME DISPLAY:** Displays the start and end time for the selected report.

**6. PAUSED AND ALARMED DISPLAY:** Displays is the system was paused or an alarm occurred during a run.

**7. INGREDIENT TOTALS DISPLAY:** Displays the total weights for each individual ingredient.

**8. BATCH TOTAL DISPLAY:** Displays the total batch weight received for the selected report.

HUB SYSTEM

**REPORT SCREEN**

**9. DISCHARGE TOTAL DISPLAY:** Displays the total amount of weight discharged for the selected report.

**10. RECORD NUMBER DISPLAY:** Displays the record number of the selected report out of the total number of reports.

**11. REPORT STATUS DISPLAY:** Displays the status for the report list manager.

**12. USB STATUS DISPLAY:** Displays 'Connected' when a USB stick is connect and 'Not Connected' when the USB is missing.

## HUB SYSTEM ALARM SCREEN

The screenshot shows an alarm screen with a table of active alarms and a control panel on the right. Callouts 1-10 identify the following elements:

Time	Status	Alarm Code	Description
2020/12/15 14:45:30	Acknowledged	IO.1	Scale Indicator not active. Check the device and cycle power if needed.
2020/12/15 14:45:30	Acknowledged	HDEV.2	Incoming air pressure is not detected. Check air pressure supply.
2020/12/15 14:46:12	Acknowledged	HDEV.1	Agitation motor requested to turn on, but is not detecting the ON signal.
2020/12/15 14:46:30	Acknowledged	HDEV.4	Discharge Valve requested to open, but is not detecting the OPEN signal.
2020/12/15 14:48:50	Acknowledged	HPRC.3	Scale volume has exceeded maximum allowed volume. Please empty before continuing
2020/12/15 14:48:52	Acknowledged	HPRC.4	Scale weight has exceeded maximum allowed weight. Please empty before continuing

Summary statistics at the bottom of the table:

- Total Entries: 6
- Errors Resolved: 6
- Viewing: 1 - 9 of 10000
- Total Errors: 0

Control panel buttons (from top to bottom):

- View All (6)
- Clear Non-Active (5)
- Alarm Reset (4)
- Alarm Silence (3)
- Delete Alarms (2)
- Tooltip Display Button (1)

Other callouts:

- 8: Points to the alarm table.
- 9: Points to the summary statistics bar.
- 10: Points to the 'Status:' label at the bottom left.

**1. TOOLTIP DISPLAY BUTTON:**  Pressing this button will present tooltip help for objects on the screen.

**2. DELETE ALARMS BUTTON:** Pressing this button will pop up a prompt for the user to delete alarms. (Shown Right)

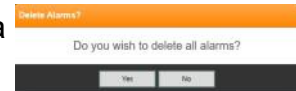

**3. ALARM SILENCE BUTTON:** Pressing this button will silence any audible alarm events.

**4. ALARM RESET BUTTON:** Pressing this button will attempt to reset any active alarms.

**5. CLEAR NON-ACTIVE BUTTON:** Pressing this button will clear any alarms with the 'Acknowledged' status from the viewable list.

**6. VIEW/HIDE ALL BUTTON:** Pressing this button will show all alarm events that are active or have been archived. Pressing this button again will hide all archived events.

**7. ALARM NAVIGATION BUTTONS:** Pressing these buttons will allow the user to scroll up and down through the list to view all events. The tall arrow is a Home or End button and will take you to the top or bottom of the list respectively. The short double arrow is a Page Up or Page Down and will take you one page up or one page down respectively. The short single arrow is a single item move and will move the list up or down one record at a time.

HUB SYSTEM

**ALARM SCREEN (Continued..)**

**8. ALARM LIST DISPLAY:** Displays a list of alarm events. The Time column indicates what time and date the alarm occurred. The Status is the current state of the alarm and can be Alarmed (Active alarm), Silenced (Active alarm, but silenced), Acknowledged (Non-active, but visible), or Archived (Non-active, but hidden). The Alarm Code indicates what automation process logged the event and its unique number. The Description details what the event is that occurred.

**9. ALARM INFO DISPLAY:** Displays details about how many events are occurring, how many events are shown, how many events have been resolved, and page viewing location information.

**10. ALARM STATUS DISPLAY:** Displays the status for the alarms list manager.

**AUTOMATION ALARMS**

<b><u>Alarm Code</u></b>	<b><u>Description</u></b>	<b><u>Possible Cause</u></b>	<b><u>Solution</u></b>
IO.1	Scale Indicator not active. Check the device and cycle power if needed.	1. Scale head is powered down or connection is not available.	1. Ensure scale head is powered on and all connections are secure.
HDEV.1	Agitation motor requested to turn on, but is not detecting the ON	1. Agitation motor starter is tripped.	1. Reset Agitation motor starter.
HDEV.2	Incoming air pressure is not detected. Check air pressure supply.	1. No pressure being supplied to HUB system.	1. Ensure that air is being supplied to the system.
HDEV.3	Discharge Pump requested to turn on, but is not detecting the ON	1. Connection to pump is disconnected.	1. Ensure that the connection between the control panel and the
HDEV.4	Discharge Valve requested to open, but is not detecting the OPEN signal.	1. Connection to valve is disconnected. 2. Valve position is stuck. 3. Air supply to valve is too low.	1. Ensure that the cable is connected between the control panel and the valve. 2. Clean valve assembly of any debris. 3. Ensure proper air supply to valve.

## HUB SYSTEM

<b><u>Alarm Code</u></b>	<b><u>Description</u></b>	<b><u>Possible Cause</u></b>	<b><u>Solution</u></b>
HPRC.1	Inbound Flow not active during Fill. Check the path from pump to valve.	<ol style="list-style-type: none"> <li>1. Path to scale tank from pump is obstructed.</li> <li>2. Scale reading not</li> </ol>	<ol style="list-style-type: none"> <li>1. Ensure all fittings and valves are open.</li> <li>2. Cycle power to scale</li> </ol>
HPRC.2	Outbound Flow not active during Discharge. Check the path from tank to destination.	<ol style="list-style-type: none"> <li>1. Path from scale tank is obstructed.</li> <li>2. Discharge pump not pulling fluid from scale tank.</li> <li>3. Scale reading not</li> </ol>	<ol style="list-style-type: none"> <li>1. Ensure all fittings and valves are open.</li> <li>2. Ensure discharge pump is primed with fluid.</li> <li>3. Cycle power to scale</li> </ol>
HPRC.3	Scale volume has exceeded maximum allowed volume. Please	<ol style="list-style-type: none"> <li>1. Too much product on the scale tank.</li> </ol>	<ol style="list-style-type: none"> <li>1. Empty the scale tank.</li> </ol>
HPRC.4	Scale weight has exceeded maximum allowed weight. Please	<ol style="list-style-type: none"> <li>1. Too much product on the scale tank.</li> </ol>	<ol style="list-style-type: none"> <li>1. Empty the scale tank.</li> </ol>

HUB SYSTEM  
**MESSAGE SCREEN**

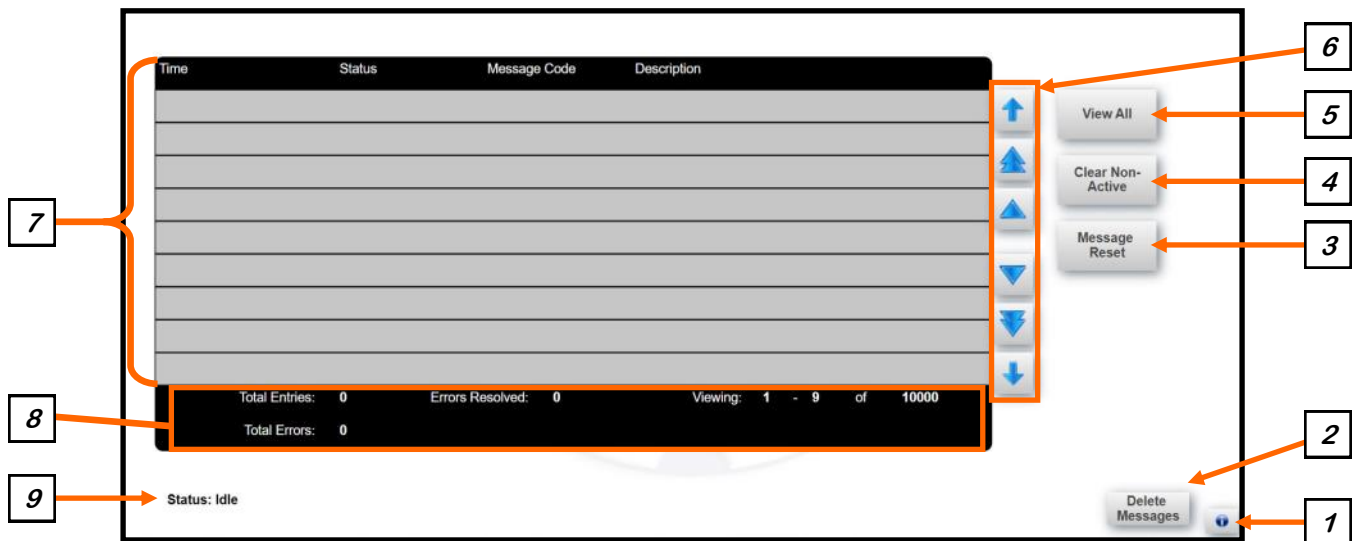

**1. TOOLTIP DISPLAY BUTTON:**  Pressing this button will present tooltip help for objects on the screen.

**2. DELETE MESSAGES BUTTON:** Pressing this button will pop up a prompt for the user to delete messages. (Shown Right)

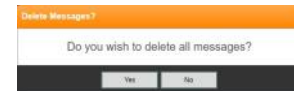

**3. MESSAGE RESET BUTTON:** Pressing this button will attempt to reset any active messages.

**4. CLEAR NON-ACTIVE BUTTON:** Pressing this button will clear any messages with the 'Acknowledged' status from the viewable list.

**5. VIEW/HIDE ALL BUTTON:** Pressing this button will show all message events that are active or have been archived. Pressing this button again will hide all archived events.

**6. MESSAGE NAVIGATION BUTTONS:** Pressing these buttons will allow the user to scroll up and down through the list to view all events. The tall arrow is a Home or End button and will take you to the top or bottom of the list respectively. The short double arrow is a Page Up or Page Down and will take you one page up or one page down respectively. The short single arrow is a single item move and will move the list up or down one record at a time.

**MESSAGE SCREEN (Continued..)**

**7. MESSAGE LIST DISPLAY:** Displays a list of message events. The Time column indicates what time and date the message occurred. The Status is the current state of the message and can be Silenced (Active, but silenced), Acknowledged (Non-active, but visible), or Archived (Non-active, but hidden). The Message Code indicates what automation process logged the event and its unique number. The Description details what the event is that occurred.

**8. MESSAGE INFO DISPLAY:** Displays details about how many events are occurring, how many events are shown, how many events have been resolved, and page viewing location information.

**9. MESSAGE STATUS DISPLAY:** Displays the status for the message list manager.



## HUB SYSTEM

### INGREDIENT CALIBRATION

This system calibrates by calculating the amount of weight a single pulse of a pump produces and also calculating the amount of time before reaching our target to stop adding the ingredient to the scale. Calibrations will not occur if the fill process alarms, pauses, or the emergency stop is pressed.

Device Details							
Pump #	Ingredient (Name/Part#)	Inventory (Units/Case)	Flow Rate (Gals)	Pulse Wt. (Lbs)	Pulse Time (Sec)	Calibrated (Checked)	Alarm Pre-Act (Seconds)
1	Alpha	6.110	33.244	0.007	50	YES	1.000
2	Beta	6.250	33.100	0.125	50	NO	1.000
3	CharLie	6.300	33.750	0.125	50	NO	1.000
4	Delta	7.000	33.404	0.200	50	YES	1.000
5	Echo	1.990	33.350	0.125	50	NO	1.000
6	Foxtrot	6.400	33.700	0.125	50	NO	1.000
7	Golf	6.300	33.404	0.000	50	YES	1.000
8	Hotel	6.250	33.700	0.125	50	NO	1.000
9	India	10.000	33.404	0.000	50	YES	1.000
10	Juliett	10.000	33.700	0.125	50	NO	1.000
11	Kilo	7.000	33.750	0.125	50	NO	1.000
12	Lima	6.000	33.700	0.125	50	NO	1.000
13	Mike	6.500	33.100	0.125	50	NO	1.000
14	November	6.700	33.404	0.200	50	YES	1.000
15	Oscar	6.000	33.100	0.125	50	NO	1.000
16	Papa	6.000	33.700	0.125	50	NO	1.000

Scale Capacity: 1000.0 lbs or 300.0 gallons  
 Scale Filter: 0.010 lbs over 0.0 seconds  
 Discharge Rate: 33.70 lbs/min

The calibration of the Pulse Weight occurs on the first ingredient use on a pump during the fill. This calibration requires **at least 6.5 pounds** to be ran for the pulse amount value to be calculated. When running an ingredient for the first time on a pump, the ingredient will fill until a stable flow rate is achieved. Once a stable enough flow rate is acquired the ingredient valve will close and wait for the scale to settle again. The valve will then pulse 5 times, waiting for the scale to settle in between, and average the amount received. If this calibrated value needs to be calculated again, the ingredient's Calibrated value attached to the pump can be unchecked to perform the calibration on the next valid fill.

The calibration of the Stream Pre-Act takes place on each run when Pulse Weight calibration is not occurring. The Stream Pre-Act calibration will occur at the end of an ingredient fill. The system will stop at the currently configured Stream Pre-Act value and adjust the new value based on how far off the value was.

## HUB SYSTEM

### AUTOMATED FILL OPERATION

1. Begin by logging into the system with the **OPERATOR/USC** credentials. This can be done by selecting the USER in the upper right hand corner on any screen.



2. Once you are logged in as an OPERATOR, navigate to the Main screen and select Pump Assign. Assign your ingredients to your pumps by using either the Ingredient Lookup or creating a new ingredient by typing the new ingredient name into an empty Ingredient Name field. You can blank out an ingredient from the pump by pressing the Clear button for that pump. Please note that only one ingredient can be used on a pump at a time. Once an ingredient is assigned, ensure that the Density of that ingredient is listed correctly. If it is not, then press the Density field to modify it. Pulse time can be left at its default value of 0.050 seconds unless fluid is not discharging during pulsing operations. Leave the Calibrated value alone. This will be updated by the system during the next calibratable run. If the user feels the pulse calibration is not accurate any more, they can return to this screen and uncheck the Calibrated check box for that ingredient. Once the ingredients have all been assigned, press the 'X' in the upper right corner to close the popup.

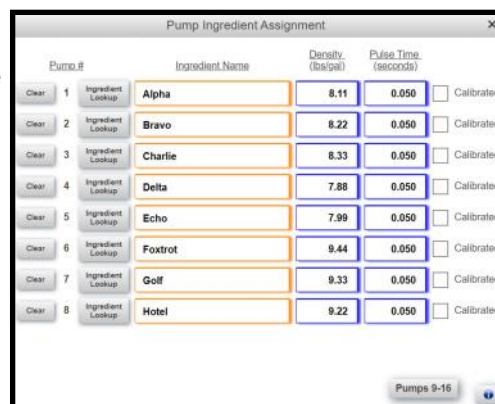

3. Navigate to the HOA page. Press the Auto All Devices button to place all devices into the Auto state. If the scale tank is empty, excess weight can be zeroed out by pressing the Zero Scale button.
4. Navigate to the Run Configuration screen. If extra amounts are needed for the configured run, it can be applied here. If not needed, then leave the Recipe Extra Quantity at 0. To automatically discharge the scale tank after the tank is filled select the check box for Auto Discharge Batch. To automatically agitate the scale tank after the tank is filled select the Auto Agitate Batch and configure the Agitation Time. Agitation is only available for systems with an agitation motor present.



## HUB SYSTEM

### **AUTOMATED FILL OPERATION**

- Return to the Main screen and select the Fill button. Begin inserting ingredients by adding the first ingredient that needs filled in the first row. The system will fill from the top of the list to the bottom. To use an ingredient that is attached a pump, select the Ingredient Lookup button and select it. To use an ingredient that is not currently on a pump, type in the Ingredient Name and provide the Density of the product. Select the desired targeting method by pressing the button in the lower left corner will switch between targeting by Application Rate or Ingredient Weight. If targeting by Application Rate, the Seed Weight will need to be provided. Once the desired targeting method is selected, enter a Target Amount for each ingredient that is used. If an ingredient is not assigned to a pump or the amount is too small, Hand Add can be pressed to fill the ingredient manually. Once satisfied with the Fill Setup, press Validate to review the process.

The screenshot shows the 'Fill Setup' window with a table of ingredients. The table has columns for Item #, Ingredient Name, Density (lb/gal), Target (lb or gal), and Hand Add. The ingredients listed are Alpha, Delta, Gamma, India, November, and two empty rows. The 'Total Target' is 35.00 lb or gal. At the bottom, there are fields for Seed Qty (lbs) and App. Rate, with a 'Validate' button.

Item #	Ingredient Name	Density (lb/gal)	Target (lb or gal)	Hand Add
1	Alpha	4.00	4.00	<input type="checkbox"/>
2	Delta	6.00	6.00	<input type="checkbox"/>
3	Gamma	8.00	8.00	<input type="checkbox"/>
4	India	8.00	8.00	<input type="checkbox"/>
5	November	8.00	8.00	<input type="checkbox"/>
6		8.35	0.00	<input type="checkbox"/>
7		8.35	0.00	<input type="checkbox"/>
8		8.35	0.00	<input type="checkbox"/>

Total Target: 35.00 lb or gal

Seed Qty (lbs): 2,000.0 lbs (Seed) App. Rate: [ ] Validate

- The Run Validation popup displays the order and task description of each task. If the system will have an issue with the configured run red text will appear and detail what needs corrected. In the example shown to the right an ingredient is too small so Hand Add will need to be selected to use that ingredient. If the configured run will exceed the capacity of the fill tank, then the system will split the batch into multiple fills. If Auto Discharge Batch is not selected and multiple fills are needed, a manual discharge will appear to prompt for a discharge when ready. At the bottom of the Run Validation popup, a summary is display for review. Once all information has been reviewed, the Start Fill button can be pressed to begin the fill process.

The screenshot shows the 'Run Validation' window with a table of tasks. The table has columns for Task #, Task Name, Hand Add Item, and Valid Check. The tasks listed are Fill [Alpha], Fill [Delta], Fill [Gamma], Fill [India], Agitation, and Auto Discharge Scale Tank. A red message at the bottom indicates that the ingredient amount is too small and suggests selecting Hand Add for the ingredient.

Task #	Task Name	Hand Add Item	Valid Check
1	Fill [Alpha], 15.00 lbs	<input type="checkbox"/>	Valid.
2	Fill [Delta], 10.00 lbs	<input type="checkbox"/>	Valid.
3	Fill [Gamma], 12.00 lbs	<input type="checkbox"/>	Valid.
4	Fill [India], 2.10 lbs	<input type="checkbox"/>	Target below recommended fill.
5	Agitation, 20 seconds	<input type="checkbox"/>	Valid.
6	Auto Discharge Scale Tank	<input type="checkbox"/>	Valid.

Ingredient amount is too small. Please select Hand Add for the ingredient.  
Batch Summary  
Target Weight: 39.10 lbs Calculated Density: 9.45 lbs/gal  
Target Volume: 4.13 gal Est. Build Time: 4.8 minutes Start Fill

The screenshot shows the 'Run Validation' window with a table of tasks. The table has columns for Task #, Task Name, Hand Add Item, and Valid Check. The tasks listed are Fill [Alpha], Fill [Delta], Fill [Gamma], Hand-Add [India], Agitation, and Auto Discharge Scale Tank. The 'Hand Add Item' column for the fourth task is checked. A red message at the bottom indicates that the ingredient amount is too small and suggests selecting Hand Add for the ingredient.

Task #	Task Name	Hand Add Item	Valid Check
1	Fill [Alpha], 15.00 lbs	<input type="checkbox"/>	Valid.
2	Fill [Delta], 10.00 lbs	<input type="checkbox"/>	Valid.
3	Fill [Gamma], 12.00 lbs	<input type="checkbox"/>	Valid.
4	Hand-Add [India], 2.10 lbs	<input checked="" type="checkbox"/>	Valid.
5	Agitation, 20 seconds	<input type="checkbox"/>	Valid.
6	Auto Discharge Scale Tank	<input type="checkbox"/>	Valid.

Batch Summary  
Target Weight: 39.10 lbs Calculated Density: 9.45 lbs/gal  
Target Volume: 4.13 gal Est. Build Time: 5.2 minutes\* Start Fill

## HUB SYSTEM

### AUTOMATED FILL OPERATION

8. During the Fill Process, similar information that was on the Run Validation popup can be found in the left column. This column will provide an order for the Tasks to be performed. The current fill progress can be found in the center column. An arrow will indicate the current product being filled. The right column will display device information to show with devices are active. The process will continue to fill until all Tasks are complete, an Alarm occurs, a Pause is initiated, or a Hand is needed.

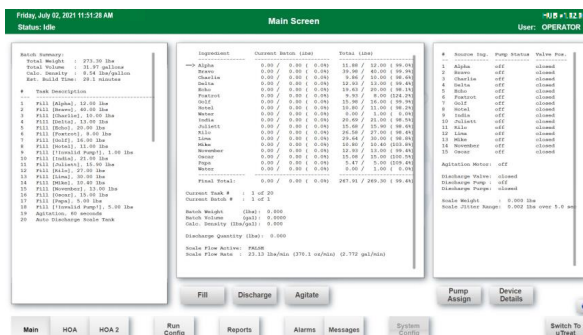

9. If a Hand Add is needed, a popup will appear requesting the Hand Add ingredient to be added. The ingredient name can be found in the upper left hand corner. The large set of numbers in the upper center portion of the screen is the amount of weight for that ingredient that has been added. While adding by hand, the grey bar on the right will fill orange as you approach your target amount. If the agitation motor is present on this system, the Agitate button can be pressed to engage the agitation motor. Pressing the Agitate button again will turn the motor off. When Hand Add is complete, press Finish to continue with the fill process.



10. If Auto Discharge Batch is not enabled and the system required multiple fills, a manual discharge will be needed. When the system needs a discharge to continue the popup shown to the right will appear. When ready to discharge OK can be pressed and the system will perform the discharge step. If the system needs to shutdown, the Cancel button can be pressed and the fill process will terminate. Ensure that the lid is closed on the tank that chemical is being discharged in to.

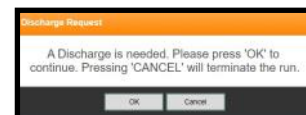

11. Once the fill process is complete navigate to the Reports screen to review the run. Select a report by pressing the blue arrow. Reports are organized by Start Time. If multiple Start Times are listed on the reports, then those reports were part of the same fill request. Displayed on the report is the amount of each ingredient processed during an automated fill. Also displayed the amount of product discharged during an automated discharge.

HUB SYSTEM

## SECTION D TROUBLESHOOTING

Below is a table describing the most frequent problems and solutions with the Product Batching System. For further assistance, contact your authorized dealer.

Problem	Possible Cause	Solution
Pump is fluctuating	<ol style="list-style-type: none"> <li>1. Restriction in line.</li> <li>2. Filter is plugged or missing gasket.</li> <li>3. Valve in wrong position or not functioning.</li> </ol>	<ol style="list-style-type: none"> <li>1. Flush hose</li> <li>2. Clean filter and check gasket.</li> <li>3. Check position and functioning of valves in that line.</li> </ol>
Mix Motor will not start	<ol style="list-style-type: none"> <li>1. Motor starter is tripped.</li> <li>2. Tank is still filling.</li> </ol>	<ol style="list-style-type: none"> <li>1. Lockout-tagout power. Press red E-Stop button. Check motor starter, viscosity of chemical, overload dial set incorrectly, low voltage, loose connections, bad motor. Remove lockout-tagout after problem is solved and press the black reset button.</li> <li>2. Wait for tank to complete the fill cycle.</li> </ol>
Scale does not register correctly	<ol style="list-style-type: none"> <li>1. Something is blocking the scale platform from moving. (example: Scale Shipping Brackets)</li> <li>2. load cell cable has come loose at the control panel.</li> <li>3. Load cell cable is damaged.</li> <li>4. Load Cell is damaged.</li> <li>5. Scale out of calibration</li> </ol>	<ol style="list-style-type: none"> <li>1. Remove item blocking the scale platform.</li> <li>2. Tighten the connection at the bottom of the control panel.</li> <li>3. Contact your authorized dealer for service.</li> <li>4. Contact your authorized dealer for service.</li> <li>5. Re calibrate scale</li> </ol>
Hose leak	<ol style="list-style-type: none"> <li>1. Loose connection.</li> <li>2. Damaged hose.</li> </ol>	<ol style="list-style-type: none"> <li>1. Tighten hose clamp.</li> <li>2. Replace hose.</li> </ol>
Valve leak	<ol style="list-style-type: none"> <li>1. Damaged valve.</li> </ol>	<ol style="list-style-type: none"> <li>1. Contact your authorized dealer for replacement valve.</li> </ol>
Alarms	Various	See page 32 for list of alarms.

**MAINTENANCE****SECTION E**

Proper maintenance of the pump is critical for peak performance, reliability and accuracy of this system. The following is a guideline for the type of maintenance and servicing that should be performed on this unit. Your environment and uses may require additional maintenance and service beyond this list to assure a reliable and safe unit. The operator of this unit has ultimate responsibility to identify areas of concern and rectify them before they become a hazard or safety issue. There is no substitute for a trained, alert operator.



Do not put this unit into operation with any questionably maintained parts. Poor performance or a hazard may occur.



Do not use compressed air or water under pressure to clean any of the components of the USC equipment.

**MIX TANK**

- Check motor.
- Check motor for any play in the mix tank shaft.
- Check valves, fittings, and plug on bottom of tank for leaks.
- Check chemical line tubing for abnormal wear.
- Wipe down the motor casing with a damp cloth making sure to remove all dust that may have collected since the last maintenance date.
- Periodically remove any chemical buildup in the tank. (A pressure washer may be used as long as the spray is restricted to the inside of the tank and the operator is adequately protected.)

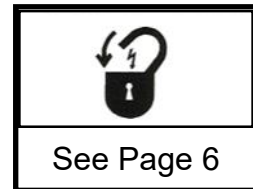
**HOSES**

- Do not leave chemical in the hoses for long periods as this may cause plugging if the chemical settles out or dries.

**PUMPS**

- Perform maintenance as outlined in the manual that came with the pumps.



## HUB SYSTEM

### **FILTERS**

- Disassemble all the filters,
- Clean filter medium.
- Clean bowl.
- Clean gasket and check for damage. If damaged a new one can be ordered through your authorized dealer.
- Dry and reassemble filters.

### **ELECTRICAL PANEL**

- Check and tighten wire connections.
- Check connections on bottom of control panel.
- Check to see if starters and/or overloads are tripped.
- Check to see if relays, timers and/or breakers are tripped.
- Check power cords for cuts or frays and ensure ground is present.



### **VALVES**

- Flush with clean water.
- Check operation. If the valve does not function properly, a replacement can be ordered from your authorized dealer.

### **GENERAL SYSTEM**

During operation, observe all hose connections, hoses, filters, and valves to check for leaks. If a leak is observed:

- Shut down the system
- Determine the cause of the leak:
- If loose connection, tighten hose clamp.
- If broken hose, replace hose
- If other damaged parts (valves, filters, etc.) contact your authorized dealer for service.
- Clean-up any spills immediately.

When storing the equipment for long periods of time, the following procedure must be followed to reduce the chance of rust, corrosion of the equipment. You can also use these steps when storing the machine for the winter.



A dust mask and protective rubber gloves shall be used when cleaning the machine.

1. Clear the area of bystanders, especially small children.
2. Perform all maintenance as outlined in the MAINTENANCE SECTION.
3. Flush all chemical lines with clear water. Dispose of contaminated water in accordance with Local, State, and Federal Regulations.
4. Be sure to remove all water from the lines.
5. Thoroughly wash the exterior of the entire machine to remove all dirt, mud, debris or residue. (DO NOT USE A PRESSURE WASHER)
6. Thoroughly wash the inside of the Mix Tank. (A pressure washer may be used as long as the spray is confined to the interior of the tank and the operator is adequately protected.)
7. Inspect all moving or rotating parts to see if anything has become entangled in them. Remove the entangled material.
8. Prepare pumps for storage according to their manuals.

**USC, LLC, MANUFACTURER WARRANTY ON SEED TREATING EQUIPMENT**

01AUG22

USC, LLC, (Manufacturer) warrants its equipment as follows:

1.Limited Warranty: Manufacturer warrants that the Products sold hereunder will be free from defects in material and workmanship for a period of 18 months from date of shipment by Manufacturer for all seed treating equipment and a period of 12 months from date of shipment by Manufacturer for all grain and fertilizer handling equipment.

If the Products do not conform to this Limited Warranty during the warranty period, Buyer shall notify Manufacturer in writing (on the approved USC warranty claim form) of the claimed defects and demonstrate to Manufacturer satisfaction that said defects are covered by this Limited Warranty (through pictures, video or other objective data). If the defects are properly reported to Manufacturer within the warranty period, and the defects are of such type and nature as to be covered by this warranty, Manufacturer shall, at its expense, furnish replacement Products or, at Manufacturer's option, replacement parts for the defective products. Shipping and installation of the replacement Products or replacement parts shall be at the Buyer's expense.

All replacement parts orders through Manufacturer will carry their specific manufacturer's standard warranty. There is no warranty on replacement parts manufactured by Manufacturer. Manufacturer will not extend any warranty due to replaced parts. The end user is responsible for all shipping and handling expenses for parts returned to Manufacturer under this section which may or may not be included in that specific warranty. Manufacturer will pay shipping expense between USC and its vendor.

2.Other Limits: THE FOREGOING IS IN LIEU OF ALL OTHER WARRANTIES, EXPRESSED OR IMPLIED, INCLUDING BUT NOT LIMITED TO THE IMPLIED WARRANTIES OF MERCHANTABILITY AND FITNESS FOR A

PARTICULAR PURPOSE. Manufacturer does not warrant against damages or defects arising from improper installation (where installation is by persons other than Manufacturer), against defects in products or components not manufactured by Manufacturer, or against damages resulting from such non-Manufacturer made products or components. Manufacturer passes on to the Buyer the warranty it received (if any) from the maker of such non-Manufacturer made products or components. This warranty also does not apply to Products upon which repairs and / or modifications have been affected or attempted by persons other than pursuant to written authorization by Manufacturer. This includes any welding on equipment which could damage electrical components. Manufacturer does not warrant against injuries or damages resulting from misuse and / or abuse of Products, improper storage or handling, acts of nature, effects of weather, including effects of weather due to outside storage, accidents, or damages incurred during transportation by common carrier or Dealer/customer arranged freight. Any replacement or repair covered under this warranty will not extend the warranty period. The remainder of the manufacturer's warranty will remain in force until stated expiration.

3.Exclusive Obligation: THIS WARRANTY IS EXCLUSIVE. The sole and exclusive obligation of Manufacturer shall be to repair or replace the defective Products in the manner and for the period provided above. Manufacturer shall not have any other obligation with respect to the Products or any part thereof, whether based on contract, tort, strict liability or otherwise. Under no circumstances, whether based on this Limited Warranty or otherwise, shall Manufacturer be liable for lost profits, lost revenue, lost sales (whether direct or indirect damages), incidental, special, punitive, indirect or consequential damages. Buyer shall make no claims for renumeration for any loss as a result of USC equipment and USC shall reject any and all claims that may arise as stated herein.

4.Other Statements: Manufacturer's employees or representatives' oral or other written statements do not constitute warranties, shall not be relied upon by Buyer, and are not a part of the contract for sale or this limited warranty. The USC Warranty Manager is the final decision point for all warranty claims.

5.Return Policy: Approval is required prior to returning goods to Manufacturer irrespective of warranty claim. Manufacturer may give a credit, less a 15% restocking fee, for goods that are returned in new, sellable condition. Items returned for warranty that are found to be not covered by the warranty will remain the property of the Buyer. The Buyer will have the

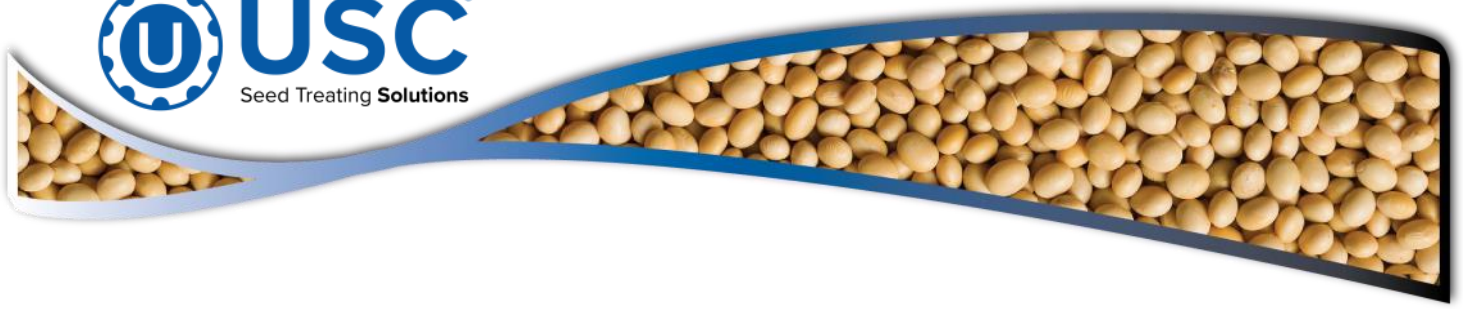

DOCUMENT REVIEW RECORD	
DATE	BY
01-21	BT
03-21	JHT
02-24	JHT

**USC, LLC**

2320 124th Road

Sabetha, KS 66534

PHONE: (785) 431-7900

EMAIL: [sales-team@uscllc.com](mailto:sales-team@uscllc.com)

