

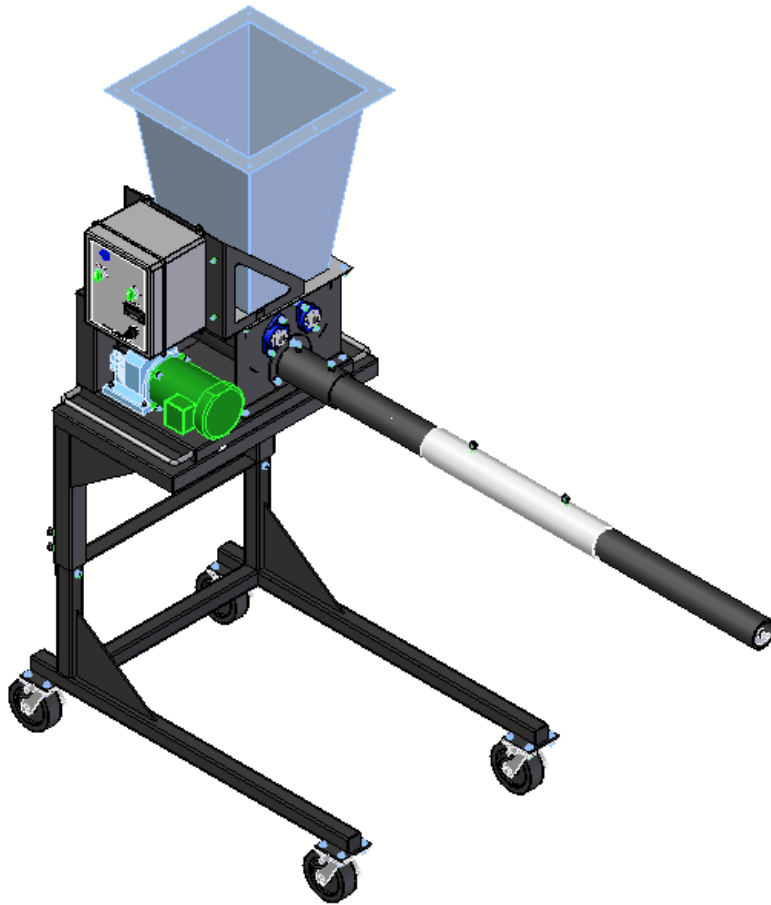

DRY ADDITIVE FEEDER 3 INCH AUGER



Operators Manual

Document: TD-09-06-1074 Revision: A Effective Date: 03-2021

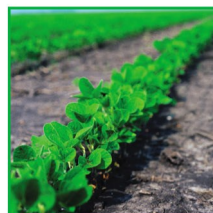

INTRODUCTION

Thank you for choosing USC, LLC for your equipment needs. We appreciate your business and will work diligently to ensure that you are satisfied with your choice.

OVERVIEW

The purpose of this manual is to provide you with the basic information needed to operate and maintain the Dry Additive Feeder. It does not hold USC, LLC liable for any accidents or injuries that may occur.

This manual only applies to Dry Additive Feeder with 3" Augers.

RECEIVING YOUR EQUIPMENT

As soon as the equipment is received, it should be carefully inspected to make certain that it has sustained no damage during shipment and that all items listed on the packing list are accounted for. If there is any damage or shortages, the purchaser must immediately notify USC, LLC. Ownership passes to purchaser when the unit leaves the USC, LLC premises. The purchaser is responsible for unloading and mounting all components of the equipment.

Document the serial number of the machine for future reference. The serialization label is located on the back side of the unit.

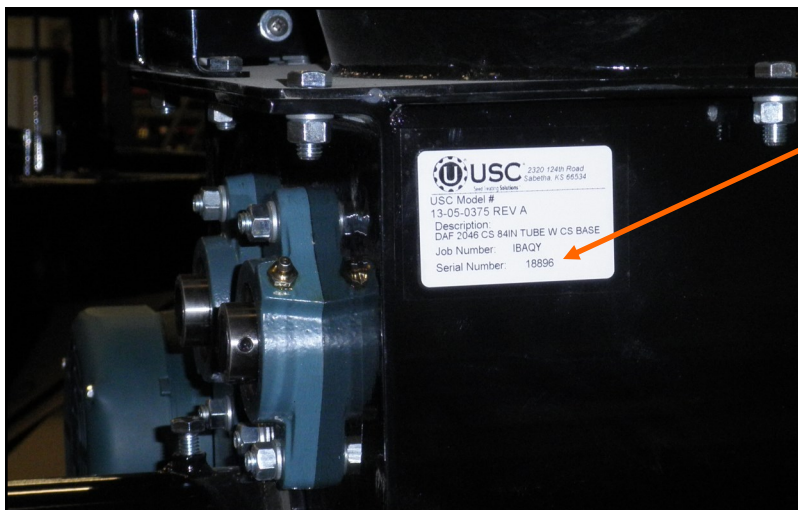

*Serial
Number*

SERIAL NUMBER: _____

TABLE OF CONTENTS

<u>Section</u>	<u>Contents</u>	<u>Page #</u>
Section A	Safety Instructions	4
Section B	Installation	11
Section C	Mechanical Operation	13
	System Overview	13
	Sprocket Configuration	15
Section D	Electrical Operation	17
Section E	Calibration	19
	Applying Dry Products	21
Section F	Troubleshooting	22
Section G	Maintenance	23
	Proximity Switch Adjustment Guide	25
Section H	Storage	26
Section J	Limited Warranty	28

SECTION **SAFETY INSTRUCTIONS**
A

Every year accidents in the work place maim, kill, and injure people. Although it may be impossible to prevent all accidents, with the right combination of training, operating practices, safety devices, and operator vigilance, the number of accidents can be significantly reduced. The purpose of this section is to educate equipment users about hazards, unsafe practices, and recommended hazard avoidance techniques.

SAFETY WORDS AND SYMBOLS

It is very important that operators and maintenance personnel understand the words and symbols that are used to communicate safety information. Safety words, their meaning and format, have been standardized for U.S. manufacturers and published by the American National Standards Institute (ANSI). The European Community (E.C.) has adopted a different format based on the International Standards Organization (I.S.O.) and applicable machinery directives. Both formats are presented below. Graphic symbols are not standardized, but most manufacturers will use some variation of the ones seen in this manual.



Indicates an imminently hazardous situation which, if not avoided, **will** result in death or serious injury.



Indicates a potentially hazardous situation which, if not avoided, **could** result in death or serious injury.



Indicates a potentially hazardous situation which, if not avoided, **may** result in minor or moderate injury and/or property damage.



Provides additional information that the operator needs to be aware of to avoid a potentially hazardous situation.



Mandatory Lockout Power Symbol. Disconnect, lockout and tagout electrical and other energy sources before inspecting, cleaning or performing maintenance on this panel.



International Safety Alert Symbol. The exclamation point (!) surrounded by a yellow triangle indicates that an injury hazard exists. However, it does not indicate the seriousness of potential injury. The exclamation point (!) is also used with the DANGER, WARNING and CAUTION symbols so the potential injury is indicated.



Electrocution Hazard Symbol. This symbol indicates that an electrocution hazard exists. Serious injury or death could result from contacting high voltage.



International Electrocution Hazard. This symbol indicates that an electrocution hazard exists. Serious injury or death could result from contacting high voltage.



Mandatory Read Manual Action Symbol. (I.S.O. format) This symbol instructs personnel to read the Operators Manual before servicing or operating the equipment.



Mandatory Read Manual Action Symbol. This symbol instructs personnel to read the Operators Manual before servicing or operating the equipment.

Notice is used to notify people of important installation, operation or maintenance information which is not hazard related.

NOTICE

LOCKOUT / TAGOUT PROCEDURES

Lockout/Tagout is the placement of a lock/tag on an energy isolating device in accordance with an established procedure. When taking equipment out of service to perform maintenance or repair work, always follow the lockout/tagout procedures as outlined in OSHA Standard 1910.147. This standard “requires employers to establish a program and utilize procedures for affixing appropriate lockout devices or tagout devices to energy isolating devices and to otherwise disable machines or equipment to prevent unexpected energizing, start-up, or release of stored energy in order to prevent injury to employees.”

HAZARD REVIEW

Electrocution Hazard



Electrocution accidents are most likely to occur during maintenance of the electrical system or when working on or near exposed high voltage wiring. This hazard does not exist when the electrical power has been disconnected, properly locked, and tagged out.

Automatic Start Hazard



This equipment may be controlled by an automated system and may start without warning. Failure to properly disconnect, lockout, and tagout all energy sources of remotely controlled equipment creates a very hazardous situation and could cause injury or even death. PLEASE STAY CLEAR AND BE ALERT.

YOU are responsible for the **SAFE** operation and maintenance of your USC, LLC equipment . **YOU** must ensure that you and anyone else who is going to operate, maintain or work around the equipment be familiar with the operating and maintenance procedures and related **SAFETY** information contained in this manual. This manual will take you step-by-step through your working day and alert you to good safety practices that should be adhered to while operating the equipment

Remember, **YOU** are the key to safety. Good safety practices not only protect you, but also the people around you. Make these practices a working part of your safety program. Be certain that **EVERYONE** operating this equipment is familiar with the recommended operating and maintenance procedures and follows all the safety precautions. Most accidents can be prevented. Do not risk injury or death by ignoring good safety practices.

- Equipment owners must give operating instructions to operators or employees before allowing them to operate the machine, and at least annually thereafter per OSHA (Occupational Safety and Health Administration) regulation 1928.57.
- The most important safety device on this equipment is a **SAFE** operator. It is the operator's responsibility to read and understand **ALL** Safety and Operating instructions in the manual and to follow them. All accidents can be avoided.
- A person who has not read and understood all operating and safety instructions is not qualified to operate the machine. An untrained operator exposes himself and bystanders to possible serious injury or death.
- Do not modify the equipment in any way. Unauthorized modification may impair the function and/or safety and could affect the life of the equipment.
- Think **SAFETY!** Work **SAFELY!**

GENERAL SAFETY

1. Read and understand the operator's manual and all safety labels before operating, maintaining, adjusting or unplugging the equipment .
2. Only trained persons shall operate the equipment . An untrained operator is not qualified to operate the machine.
3. Have a first-aid kit available for use should the need arise, and know how to use it.

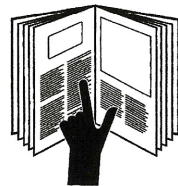

DRY ADDITIVE FEEDER 3" AUGER

4. Provide a fire extinguisher for use in case of an accident. Store in a highly visible place.
5. Do not allow children, spectators or bystanders within hazard area of machine.
6. Wear appropriate protective gear. This includes but is not limited to:

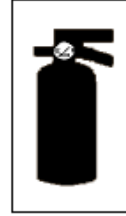

- A hard hat
- Protective shoes with slip resistant soles
- Protective goggles
- Heavy gloves
- Hearing protection
- Respirator or filter mask



7. Place all controls in neutral or off, stop motor, and wait for all moving parts to stop. Then disable power source before servicing, adjusting, repairing, or unplugging.
8. Review safety related items annually with all personnel who will be operating or maintaining the equipment.

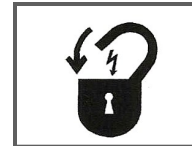

OPERATING SAFETY:

1. Read and understand the operator's manual and all safety labels before using.
2. Disconnect and disable electrical supply completely and wait for all moving parts to stop before servicing, adjusting, repairing or unplugging.
3. Clear the area of bystanders, especially children, before starting.
4. Be familiar with the machine hazard area. If anyone enters hazard area, shut down machine immediately. Clear the area before restarting.
5. Keep hands, feet, hair and clothing away from all moving and/or rotating parts.
6. Stay away from overhead obstructions and power lines during operation and transporting. Electrocution can occur without direct contact.
7. Do not operate machine when any guards are removed.
8. Inspect welds and repair if needed.

PLACEMENT SAFETY

1. Move only with the appropriate equipment
2. Stay away from overhead power lines when moving equipment. Electrocutation can occur without direct contact.
3. Be familiar with machine hazard area. If anyone enters hazard areas, shut down machine immediately. Clear the area before restarting.
4. Operate the equipment on level ground free of debris. Anchor the equipment to prevent tipping or upending.



Before placement of the equipment , be sure that ground is reasonably level. The equipment may topple or work improperly if the ground is too uneven, damaging the equipment and/or causing personal injury.

MAINTENANCE SAFETY

1. Review the operator's manual and all safety items before working with, maintaining or operating the equipment .
2. Place all controls in neutral or off, stop motors, disable power source, and wait for all moving parts to stop before servicing, adjusting, repairing or unplugging.
3. Follow good shop practices:
Keep service area clean and dry.
Be sure electrical outlets and tools are properly grounded.
Use adequate light for the job at hand.
4. Keep hands, feet, hair and clothing away from all moving and/or rotating parts.
5. Clear the area of bystanders, especially children, when carrying out any maintenance and repairs or making any adjustments.
6. Before resuming work, install and secure all guards when maintenance work is completed.
7. Keep safety labels clean. Replace any sign that is damaged or not clearly visible.



SAFETY LABELS

1. Keep safety labels clean and legible at all times.
2. Replace safety labels that are missing or have become illegible.
3. Replaced parts that displayed a safety sign should also display the current sign.
4. Replacement safety labels are available. Contact your authorized dealer.

How to Install Safety Labels:

- Be sure that the installation area is clean and dry.
- Be sure temperature is above 50°F (10°C).
- Decide on the exact position before you remove the backing paper.
- Remove the smallest portion of the split backing paper.
- Align the sign over the specified area and carefully press the small portion with the exposed sticky backing in place.
- Slowly peel back the remaining paper and carefully smooth the remaining portion of the sign in place.
- Small air pockets can be pierced with a pin and smoothed out using the piece of sign backing paper.



Located on the USC equipment you will find safety labels. Always be sure to read and follow all directions on the labels.



Part # 09-02-0001



Part # 09-02-0009



Part # 09-02-0012



Guards provided with USC equipment are to remain in place during operation.

INSTALLATION SECTION B



HIGH VOLTAGE ~ Always disconnect the power source before working on or near the control panel or lead wires.



HIGH VOLTAGE ~ Use insulated tools when making adjustments while the controls are under power.



Permanent installation may require additional electrical cords, liquid hose, and air lines, since each installation is unique.

SET-UP

The following steps outline the initial set-up of the Dry Additive Feeder:

1. Clear the area of bystanders, especially small children, before moving.
2. Place the Dry Additive Feeder in the desired position on a level surface. The Dry Additive Feeder top assembly is bolted to the Adjustable Stand Assembly. It may be rotated in 90 degree increments to allow for an easier working position in relation to other components such as the discharge conveyor.



USC highly recommends that the equipment be set up inside a building or any covered structure to protect the machine from weathering.

3. The control panel must be connected to a 120-volt single phase source.
4. The Dry Additive Feeder may be installed in conjunction with a seed treater. This will allow the rotating drum to mix the dry product being applied with the seed. The top portion of the dry additive can be rotated and the height can be adjusted to accommodate most systems.



Dry Additive Feeder in Conjunction with Seed Treater

5. Connect the 2-wire cable (PJ114) coming from the Dry Additive Feeder control panel to the auxiliary receptacle located on the bottom of the seed treater control panel. This will allow the operator to control the Dry Additive Feeder in the AUTO mode (see page 18).

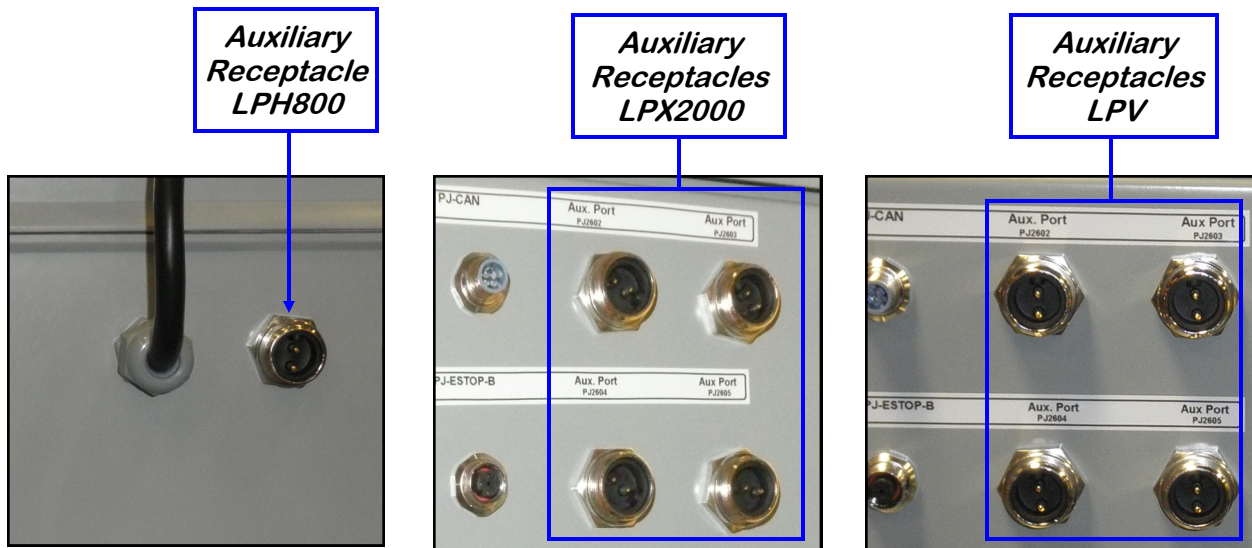

NOTICE

Some seed treaters may not be pre-wired with the auxiliary receptacle. Contact your local dealer for a kit to mount this receptacle in the seed treater control panel.

Part number: 03-12-0014.

MECHANICAL OPERATION SECTION C

SYSTEM OVERVIEW

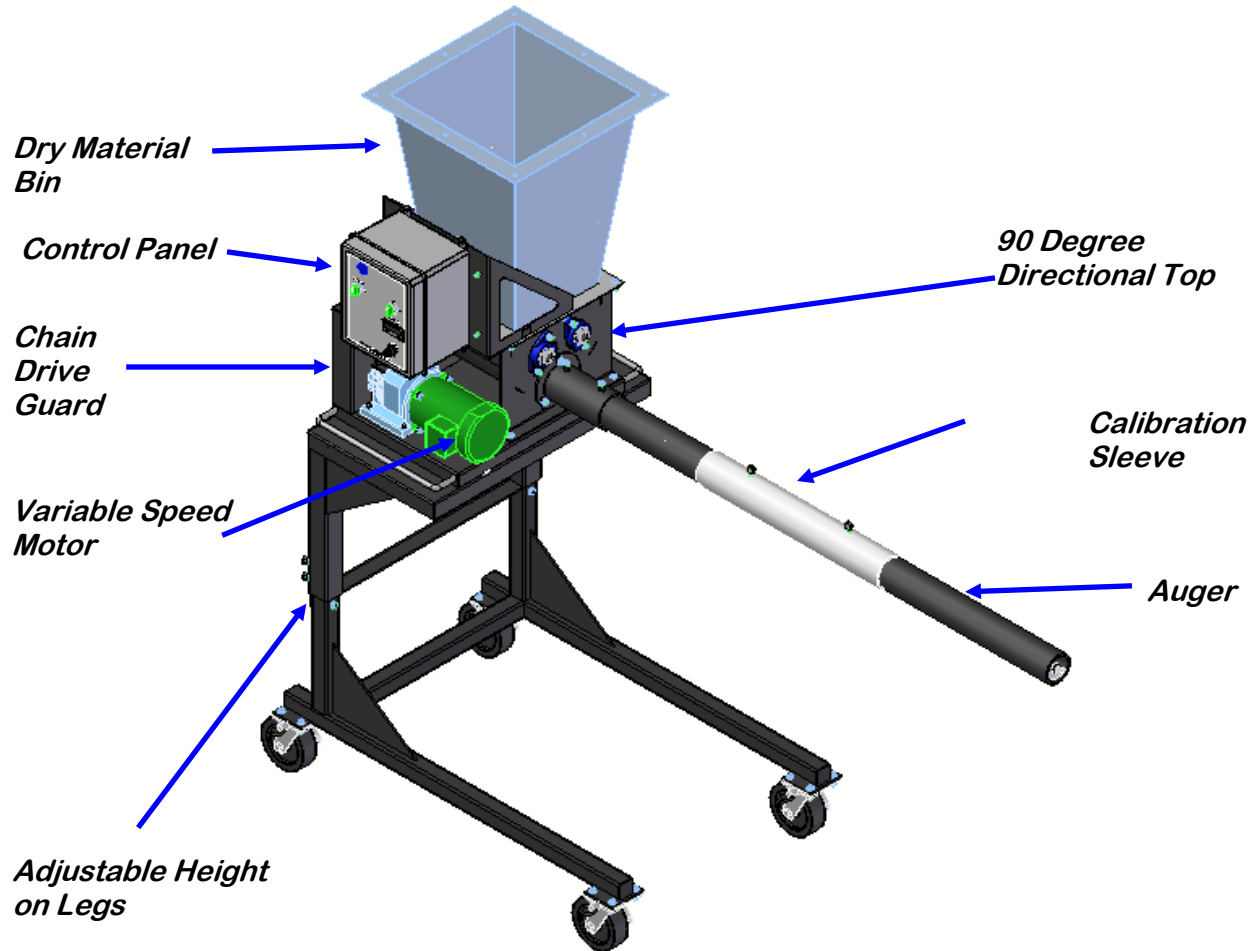

SYSTEM OVERVIEW

The USC Dry Additive Feeder is equipped with a holding bin, it has a capacity of 3.25 cubic feet. A 2 inch by 7 foot long auger is used to apply the dry products. Agitation paddles keep the product sifted so it feeds more efficiently into the auger. A variable speed motor drives the feeder auger and agitation paddles. The dry products are dispensed through openings in the last 22 inches of the auger tube.

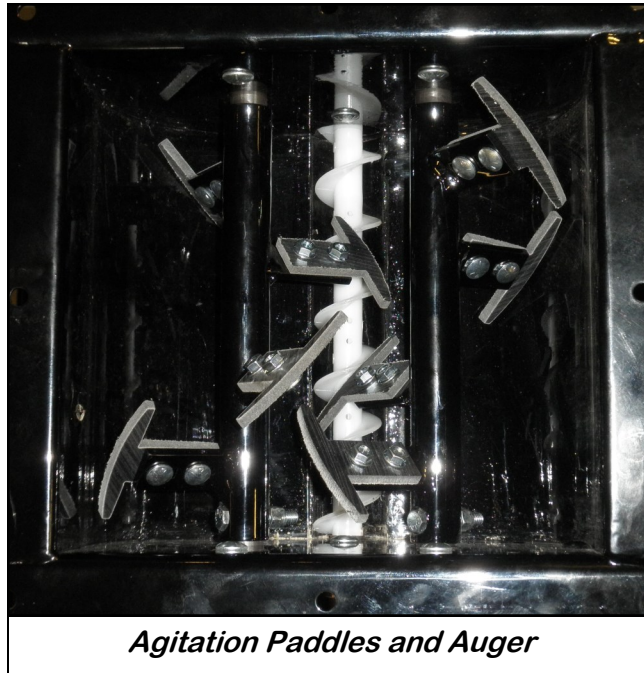

The dry product is dispensed through small openings in the auger tube to create a curtain effect when the dry products are applied. The tube may be rotated to increase or decrease the coverage area.



SPROCKET CONFIGURATION

Proper calibration of the system is critical to achieve a proper application. The feeder auger is controlled by a variable speed motor. Controls on the main panel include a counting dial which controls the auger speed and a RPM indicator that displays the RPM of the auger. Use the calibration sleeve and measuring cup to determine the amount of dry product being dispensed. Rates should be determined in QTY/TIME. This will allow for proper mixtures.

The drive portion of the dry additive feeder may be re-configured to allow the motor to operate at a higher speed when the rate of product needed is low. For higher rates, the larger sprocket (30 tooth) should be mounted to the motor, and the smaller sprocket (21 tooth) should be mounted on the auger. Interchange the two sprockets if a very low rate is desired. For example, when using the dry additive feeder with a LPH800 treater, the smaller sprocket should be mounted to the motor. And when using the dry additive feeder with a LPX2000, the larger sprocket should be mounted to the motor (see below).

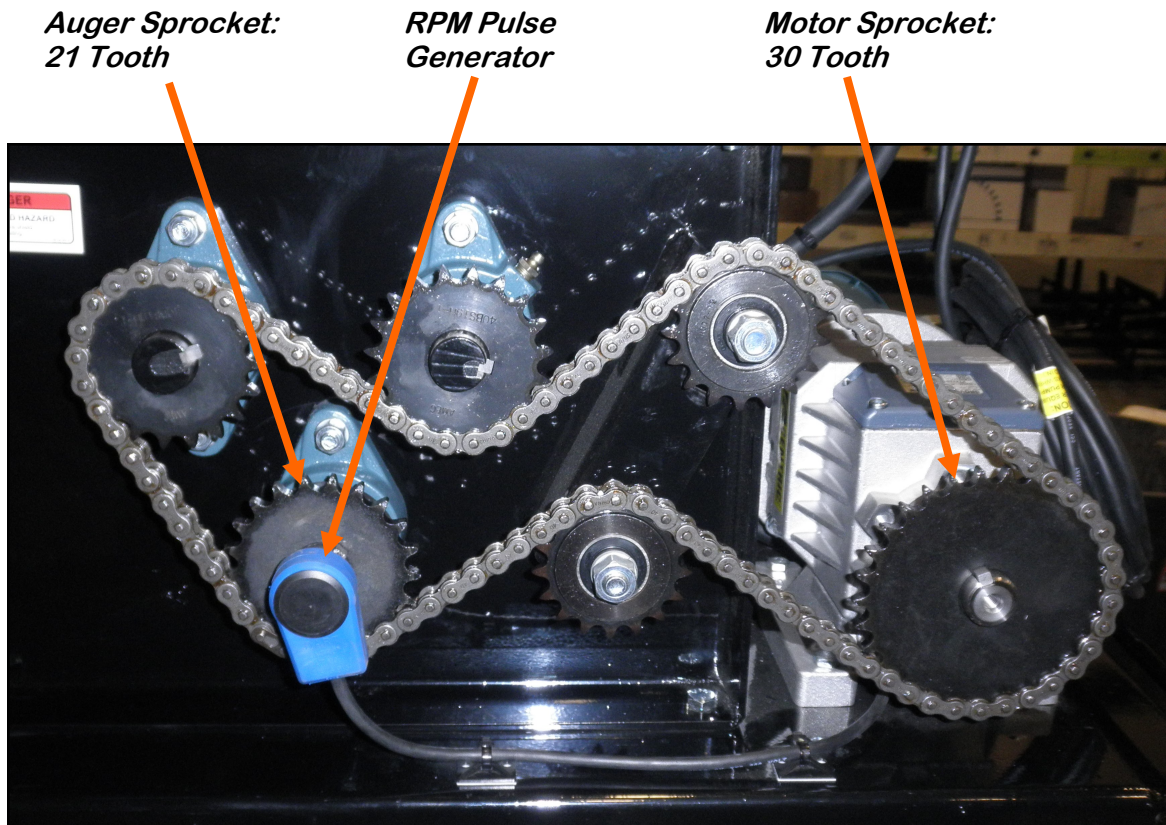

Sprocket configuration set up for use with LPX2000 Seed Treater

SPROCKET CONFIGURATION

⚠ WARNING

Before interchanging the motor and auger sprockets, be sure and mark the two agitation paddle shafts with arrows as illustrated below. Line the arrows back up when reinstalling the sprockets. Failure to line shafts back in original positions may cause the agitation paddles to collide and damage the machine.



Agitation Paddle Shafts

ELECTRICAL OPERATION SECTION D



HIGH VOLTAGE ~ Always disconnect the power source before working on or near the control panel or lead wires.



HIGH VOLTAGE ~ Use insulated tools when making adjustments while the controls are under power.



AUTHORIZED PERSONNEL only shall work on the control panel. Never allow anyone who has not read and familiarized themselves with the owner's manual to open or work on the control panels.

MAIN CONTROL PANEL

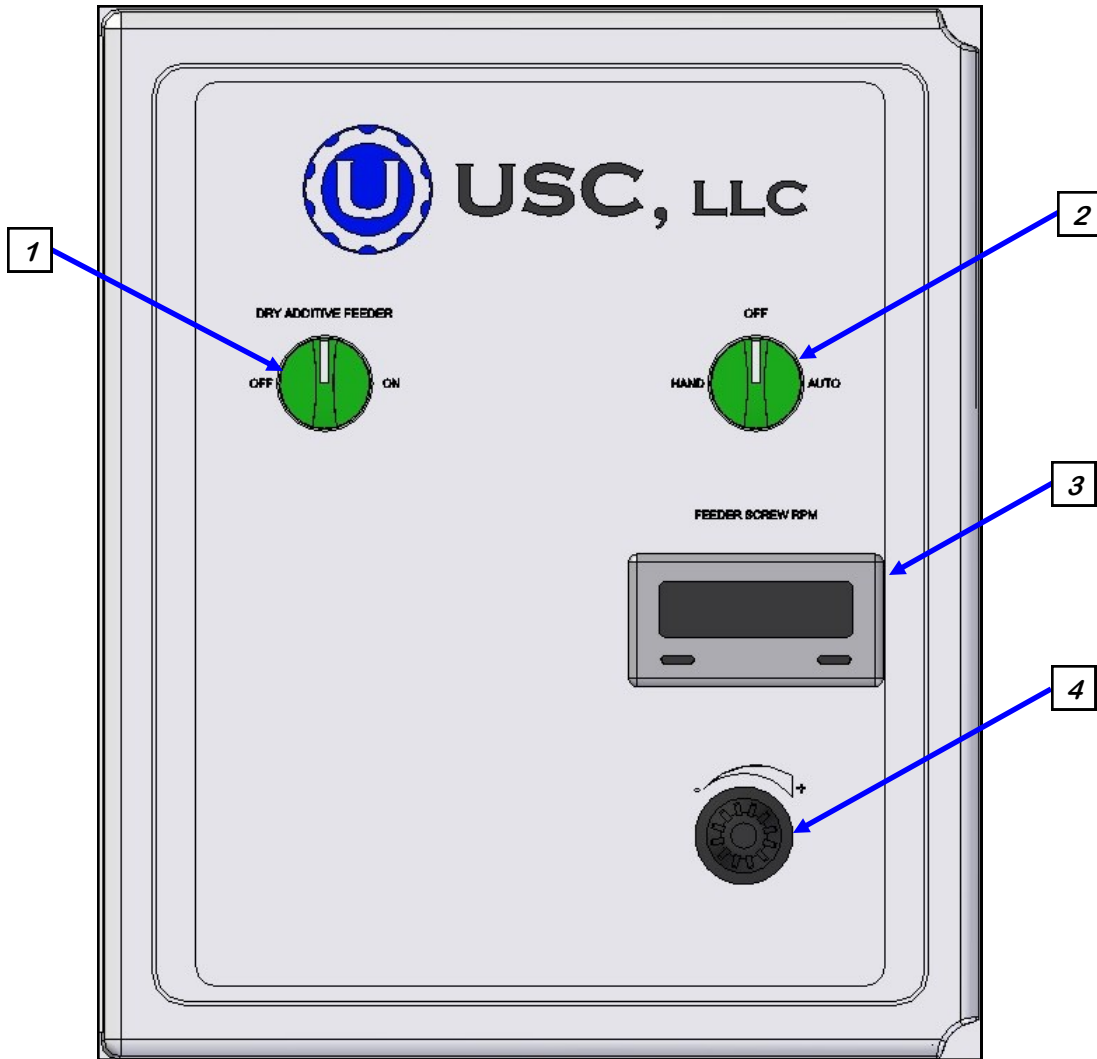

1. DRY ADDITIVE FEEDER SWITCH: This switch turns the power to the Dry Additive Feeder control panel ON and OFF. It will spring return to the vertical position. Nothing on the Dry Additive Feeder will operate unless the switch is in the ON position.

2. HAND / OFF / AUTO SWITCH: When this switch is turned to HAND, the feeder will operate in the manual mode of operation. This will run continuously until the switch is returned to the OFF position, or the dry additive feeder switch is turned to the OFF position. When the switch is turned to AUTO, the feeder will operate in the automated mode of operation. The feeder will only work in AUTO mode when the two wire cable from the feeder control panel (PJ114) is connected to an auxiliary port connector on the treater control panel.

When the treater has a seed wheel, the active signal will only be sent when the proximity sensor in the seed wheel detects seed. When the treater does not have a seed wheel, the active signal will only be sent to the feeder when the proximity switch located in the bottom of the seed treater supply hopper detects seed. When the proximity switch detects seed, a timer relay located inside the feeder control panel will automatically turn the feeder ON a pre-determined amount of time after the signal is active. The timer relay (right) is set to Mode A and has an adjustable knob with settings from 0-6. Each number represents one second. When the proximity switch no longer detects seed, another timer relay located inside the control panel will automatically shut the feeder OFF a pre-determined amount of time after the signal is no longer active. The timer relay (left) is set to Mode D and has an adjustable knob with settings from 0-6. Each number represents one second. The time delay allows all seed in the hopper to receive complete coverage. This factory default setting for both timer relays is 2 seconds. The operator may need to adjust one or both depending on their individual setup

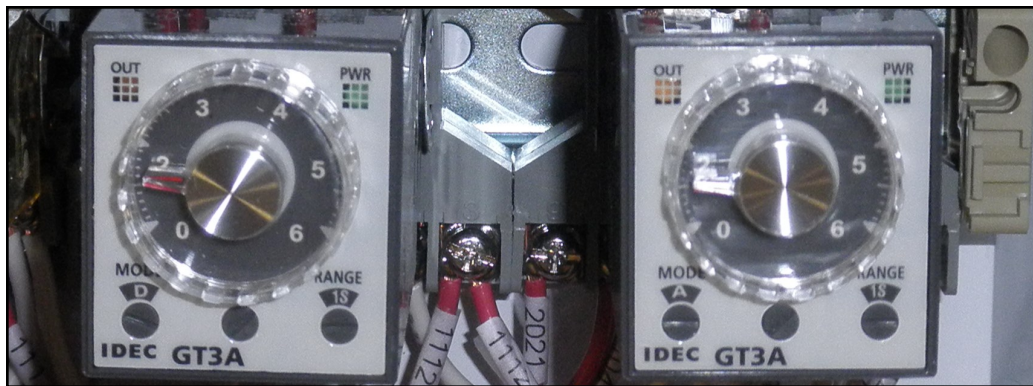

3. FEEDER SCREW RPM DISPLAY: This displays the RPM of the feeder auger.

4. FEEDER SCREW SPEED CONTROL POTENTIOMETER: This dial controls the speed of the feeder auger and agitation paddles. As you turn the dial clockwise, the drive motor speed increases and the FEEDER SCREW RPM increases as well.

CALIBRATION SECTION E

Calibration of both the seed flow and dry portions of the equipment is necessary for accurate treatment of seed.

NOTICE

If you prefer metric measurements, please refer to the conversion chart on page 21.

DRY PRODUCT CALIBRATION

When calibrating the dry product, a small scale, a stop watch, and a measuring cup or bucket will be needed.

1. Calibrate the seed flow of the seed treater before calibrating the Dry Additive Feeder. Seed flow calibrations should be done with at least 40 units or 2000 lbs of seed.
2. Fill the supply hopper with the dry product being applied.
3. Slide the calibration sleeve toward the end of the auger tube to cover the distribution slots. (right).
4. Place the HAND / OFF / AUTO switch in the HAND position.
5. Turn the DRY ADDITIVE FEEDER switch to ON and adjust the FEEDER SCREW RPM to approximately 3/4 speed. This will allow product to fill the auger all the way to the end of the tube. Use the measuring cup or bucket to catch the product as it empties out the end of the tube. Continue running the auger until there is a consistent stream of product coming out the end. Then turn the DRY ADDITIVE FEEDER switch to OFF.
6. Determine the number of ounces needed in one minute.



Calibration Sleeve at end of Auger Tube

EXAMPLE:

The product rate is 4 ounces per cwt.
 The Seed Flow Rate = 876 lbs per minute or 8.76 cwt./min.
 $8.76 \text{ cwt./min} \times 4 \text{ oz. product/cwt.} = 35 \text{ oz./min.}$
 35 oz. is the rate the feeder auger should be applying in one minute.

DRY ADDITIVE FEEDER 3" AUGER

7. Set the FEEDER SCREW speed. After the RPM is set, empty the product that was caught back into the feeder and go on to the next step.

EXAMPLE: The ounces needed in one minute = 35 oz/min.
Assume the weight of the product being used is approximately 40 pounds per cubic foot. A good starting point is approximately 27 RPM's.

8. Place the measuring cup on the scale and zero the weight of the cup. Use the stop watch and measuring cup to determine the auger flow rate. Turn the DRY ADDITIVE FEEDER switch to ON. As soon as product begins flowing into the cup, begin timing for one minute. As soon as one minute is reached, turn the DRY ADDITIVE FEEDER switch to OFF.
9. Place the cup of product on the scale to measure the amount of product that was dispensed in one minute. If the rate differs than what is desired, adjust the FEEDER SCREW speed accordingly until the desired application rate is achieved.

APPLYING DRY PRODUCTS.

1. Position the Dry Additive Feeder and all conveyors, hoppers, or pro boxes in place.
2. Turn the HAND / OFF / AUTO switch to AUTO, turn the DRY ADDITIVE FEEDER SWITCH to ON. Turn the seed treater switch to AUTO and any other conveyor or seed treater switches to ON.
3. With all motors turned to the ON position, you are ready for seed.
4. Begin feeding seed into the seed treater. If you are using the AUTO function, the proximity switch in the seed treater will start the Dry Additive Feeder automatically. If you are not using the AUTO function, you will need to start the Dry Additive Feeder as soon as seed lands in the seed treater drum.
5. When all seed has passed by the proximity switch, the Dry Additive Feeder will automatically shut off. If you are not using the AUTO function, you will need to turn the DRY ADDITIVE FEEDER to OFF.

Conversion Chart

1 ounce = 29.58 milliliters

1 gallon = 3.79 liters

1 kilogram = 2.2 pounds

1 unit = 50 lbs or 22.73 kg

1 bushel = approx. 60 lbs or 27.27 kg

1 cwt = 100 lbs or 45.45 kg

SECTION F TROUBLESHOOTING

Below is a table describing the most frequent mechanical problems and solutions with the USC Dry Additive Feeder. For further assistance, contact your authorized dealer.

Problem	Possible Cause	Solution
Dry Additive Feeder will not turn on in AUTO	<ol style="list-style-type: none"> 1. Proximity Switch in treater is not detecting seed. 2. Proximity switch in treater is not sensitive enough. 3. Atomizer is not running. 	<ol style="list-style-type: none"> 1. Clean proximity switch. 2. Adjust proximity switch clockwise to make more Sensitive (see page 25). 3. Turn on atomizer.
Dry Additive Feeder will not turn off in AUTO when seed runs out.	<ol style="list-style-type: none"> 1. Proximity Switch in treater is still detecting seed after run. Switch is dirty. 2. Proximity Switch is too sensitive. 	<ol style="list-style-type: none"> 1. Clean proximity Switch 2. Adjust proximity switch counter-clockwise to make less Sensitive (see page 25).
Feeder Rate is Fluctuating.	<ol style="list-style-type: none"> 1. Product is not feeding into auger. 2. Agitators are not working properly. 3. Running auger too slow. 	<ol style="list-style-type: none"> 1. Check to see if product is feeding into the auger. 2. Check tightness on chain 3. Interchange sprockets to make auger shaft to run faster (see pages 15-16).
Auger will not turn.	<ol style="list-style-type: none"> 1. Agitation paddles are hitting each other. 2. Chain is loose. 	<ol style="list-style-type: none"> 1. Readjust agitation paddles so they do not collide when running. 2. Check tightness on chain.

**SECTION
G**

MAINTENANCE

Proper maintenance of the USC Dry Additive Feeder is critical for peak performance, reliability and accuracy of this system. The following is a guideline for the type of maintenance and servicing that should be performed on this unit. Your environment and uses may require additional maintenance and service beyond this list to assure a reliable and safe unit. The operator of this unit has ultimate responsibility to identify areas of concern and rectify them before they become a hazard or safety issue. There is no substitute for a trained, alert operator.



Do not put this unit into operation with any questionably maintained parts. Poor performance or a hazard may occur.

GREASING

Use an SAE multipurpose high temperature grease with extreme pressure (EP) performance. Also acceptable is an SAE multipurpose lithium-based grease.

1. Use a Maintenance Checklist to keep record of all scheduled maintenance.
2. Use a hand-held grease gun for all greasing.
3. Wipe grease fitting with a clean cloth before greasing to avoid injecting dirt and grit.
4. Replace and repair broken fittings immediately.

NOTICE

If fittings will not take grease, remove and clean thoroughly. Also clean lubricant passageway. Replace fitting if necessary.

SUPPLY HOPPER

1. Periodically clean out any build up of dry material in the hopper.
2. Check agitation paddles for wear, breaks or an loose fasteners.
3. Check auger for wear or breaks.

CHAIN DRIVE AND BEARINGS

1. Remove chain drive guard and inspect all welds and structural components on the frame bends, cracks and damage.
2. Tighten and lubricate chain every 40 hours of operation.
3. Inspect pillow block bearings and grease every 40 hours of operation.

ELECTRICAL PANEL

1. Check and tighten wire connections.
2. Check quick connects on bottom of control panel.
3. Check to see if starters and/or overloads are tripped.
4. Check to see if relays, timers and/or breakers are tripped.
5. Check quick connects on end of Auxiliary cord.
6. Check and tighten wire connections.
7. Check relay and fuse holder.
8. Check power cords for cuts or frays and ensure ground is present.

PROXIMITY SWITCH ADJUSTMENT GUIDE

If a proximity switch is not working properly, this can be caused by wear, dust, or even moisture. The first step is to clean the lens of the proximity switch. If this does not solve the problem, the next step would be to adjust the sensitivity of the proximity switch.

The LED lights indicates the power status. If they are active the device is powered.

The center LED is when the switch closes.

Using the small screwdriver, you can adjust the proximity switch by turning the sensitivity dial of the proximity switch.

- Turn Clockwise to make the proximity switch more sensitive.
- Turn Counterclockwise to make the proximity switch less sensitive.



SECTION H STORAGE

When storing the USC Dry Additive Feeder for long periods of time, the following procedure must be followed to reduce the chance of rust, corrosion and fatigue of the equipment. You can also use these steps when storing the machine for the winter.



A dust mask and protective rubber gloves shall be used when cleaning the machine.

1. Clean out the supply hopper of any debris (compressed air may be used).
2. Remove auger tube and clean the auger (compressed air may be used). Then reinstall the auger tube.
3. Remove the drive chain guard and clean out any material that may have fallen behind the guard.
4. Follow the maintenance procedures specified for the chain drive and bearings on page 24.
5. Disconnect power to the machine.
6. Store the machine inside a protective building to keep it from being exposed to the weather.
7. Cover the Dry Additive Feeder with a tarpaulin to keep dust and dirt out of the machine.

DRY ADDITIVE FEEDER 3" AUGER

NOTES:

SECTION I LIMITED WARRANTY

USC, LLC, MANUFACTURER WARRANTY ON SEED TREATING EQUIPMENT

01AUG22

USC, LLC, (Manufacturer) warrants its equipment as follows:

1.Limited Warranty: Manufacturer warrants that the Products sold hereunder will be free from defects in material and workmanship for a period of 18 months from date of shipment by Manufacturer for all seed treating equipment and a period of 12 months from date of shipment by Manufacturer for all grain and fertilizer handling equipment.

If the Products do not conform to this Limited Warranty during the warranty period, Buyer shall notify Manufacturer in writing (on the approved USC warranty claim form) of the claimed defects and demonstrate to Manufacturer satisfaction that said defects are covered by this Limited Warranty (through pictures, video or other objective data). If the defects are properly reported to Manufacturer within the warranty period, and the defects are of such type and nature as to be covered by this warranty, Manufacturer shall, at its expense, furnish replacement Products or, at Manufacturer's option, replacement parts for the defective products. Shipping and installation of the replacement Products or replacement parts shall be at the Buyer's expense.

All replacement parts orders through Manufacturer will carry their specific manufacturer's standard warranty. There is no warranty on replacement parts manufactured by Manufacturer. Manufacturer will not extend any warranty due to replaced parts. The end user is responsible for all shipping and handling expenses for parts returned to Manufacturer under this section which may or may not be included in that specific warranty. Manufacturer will pay shipping expense between USC and its vendor.

2.Other Limits: THE FOREGOING IS IN LIEU OF ALL OTHER WARRANTIES, EXPRESSED OR IMPLIED, INCLUDING BUT NOT LIMITED TO THE IMPLIED WARRANTIES OF MERCHANTABILITY AND FITNESS FOR A

PARTICULAR PURPOSE. Manufacturer does not warrant against damages or defects arising from improper installation (where installation is by persons other than Manufacturer), against defects in products or components not manufactured by Manufacturer, or against damages resulting from such non-Manufacturer made products or components. Manufacturer passes on to the Buyer the warranty it received (if any) from the maker of such non-Manufacturer made products or components. This warranty also does not apply to Products upon which repairs and / or modifications have been affected or attempted by persons other than pursuant to written authorization by Manufacturer. This includes any welding on equipment which could damage electrical components. Manufacturer does not warrant against injuries or damages resulting from misuse and / or abuse of Products, improper storage or handling, acts of nature, effects of weather, including effects of weather due to outside storage, accidents, or damages incurred during transportation by common carrier or Dealer/customer arranged freight. Any replacement or repair covered under this warranty will not extend the warranty period. The remainder of the manufacturer's warranty will remain in force until stated expiration.

3.Exclusive Obligation: THIS WARRANTY IS EXCLUSIVE. The sole and exclusive obligation of Manufacturer shall be to repair or replace the defective Products in the manner and for the period provided above. Manufacturer shall not have any other obligation with respect to the Products or any part thereof, whether based on contract, tort, strict liability or otherwise. Under no circumstances, whether based on this Limited Warranty or otherwise, shall Manufacturer be liable for lost profits, lost revenue, lost sales (whether direct or indirect damages), incidental, special, punitive, indirect or consequential damages. Buyer shall make no claims for remuneration for any loss as a result of USC equipment and USC shall reject any and all claims that may arise as stated herein.

4.Other Statements: Manufacturer's employees or representatives' oral or other written statements do not constitute warranties, shall not be relied upon by Buyer, and are not a part of the contract for sale or this limited warranty. The USC Warranty Manager is the final decision point for all warranty claims.

5.Return Policy: Approval is required prior to returning goods to Manufacturer irrespective of warranty claim. Manufacturer may give a credit, less a 15% restocking fee, for goods that are returned in new, sellable condition. Items returned for warranty that are found to be not covered by the warranty will remain the property of the Buyer. The Buyer will have the ability to have part returned at their expense or, if in new, sellable condition, receive a credit less a 15% restocking fee and less any USC paid freight for its return.

6.Entire Obligation: This Limited Warranty states the entire obligation of Manufacturer with respect to the Products. If any part of this Limited Warranty is determined to be void or illegal, the remainder shall remain in full force and effect. Other terms included in Manufacturer's Terms of Sale will also apply.

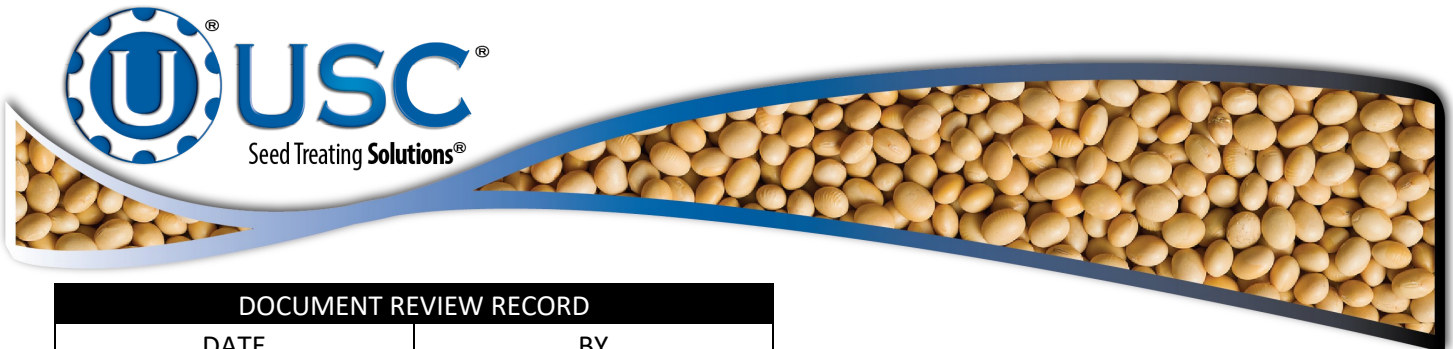

DOCUMENT REVIEW RECORD	
DATE	BY
08-2020	BT
3-18-21	ADM

USC, LLC

2320 124th Road

Sabetha, KS 66534

PHONE: (785) 431-7900

EMAIL: sales-team@uscllc.com

WEB: www.uscllc.com

