

# OPEN TOP FIELD LOADER CONVEYOR

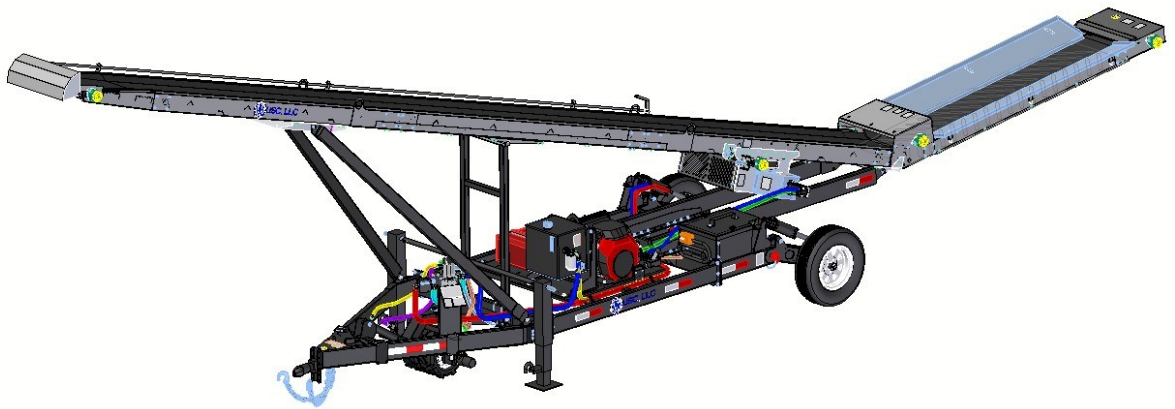

## OPERATOR'S MANUAL

Document: TD-09-06-1080

Revision: A

Effective Date: Jan. 2024

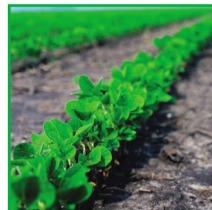

# INTRODUCTION

Thank you for choosing USC, LLC for your equipment needs. We appreciate your business and will work diligently to ensure that you are satisfied with your choice.

## OVERVIEW

The purpose of this manual is to provide you with the basic information needed to operate and maintain the Open Top Field Loader Conveyor. It does not hold USC, LLC liable for any accidents or injuries that may occur.

The technical information provided in this document is based on extensive testing under controlled conditions at the USC research and development facility. This information is given without guarantee as the conditions of operation and storage of the equipment are beyond our control.

## RECEIVING YOUR EQUIPMENT

As soon as the equipment is received, it should be carefully inspected to make certain that it has sustained no damage during shipment and that all items listed on the packing list are accounted for. If there is any damage or shortages, the purchaser must immediately notify USC, LLC. Ownership passes to purchaser when the unit leaves the USC LLC premises. The purchaser is responsible for unloading and mounting all components of the equipment.

Document the serial number of the machine for future reference. The serialization label is located on the inlet end near the transition.

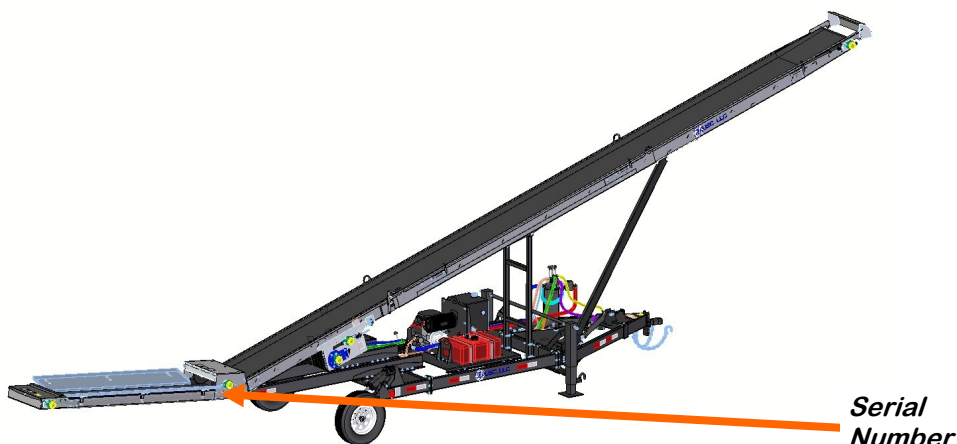

**SERIAL NUMBER:** \_\_\_\_\_

# TABLE OF CONTENTS

<b><u>Section</u></b>	<b><u>Contents</u></b>	<b><u>Page #</u></b>
<b>Section A</b>	<b>Safety Instructions</b> .....	<b>4</b>
	Safety Labels .....	14
<b>Section B</b>	<b>Mechanical Operation</b> .....	<b>19</b>
	Pre-Operation Check List.....	20
	Operating Hints .....	20
	Emergency Stopping, Restarting, Machine Break-in.....	21
	Open Top Field Loader Conveyor Overview .....	22
	Conveyor Trailer Operation .....	23
	Gas Powered Power Pack .....	24
	Starting Engine.....	24
	Self Mover.....	27
	Remote Control .....	29
	Learning the Remote.....	30
Adjusting & Checking Hydraulic Pressure .....	31	
<b>Section C</b>	<b>Troubleshooting</b> .....	<b>32</b>
<b>Section D</b>	<b>Maintenance</b> .....	<b>33</b>
	Conveyor Servicing Intervals .....	34
	Belt Tensioning and S-Drive Alignment.....	35
	Conveying Belt Alignment .....	36
	Belt Alignment - Head End.....	37
	Belt Replacement.....	38
<b>Section E</b>	<b>Storage</b> .....	<b>39</b>
<b>Section F</b>	<b>Limited Warranty</b> .....	<b>41</b>

SECTION  
A**SAFETY INSTRUCTIONS**

Every year accidents in the work place maim, kill and injure people. Although it may be impossible to prevent all accidents, with the right combination of training, operating practices, safety devices and operator vigilance, the number of accidents can be significantly reduced. The purpose of this section is to educate equipment users about hazards, unsafe practices and recommended hazard avoidance techniques.

**SAFETY WORDS AND SYMBOLS**

It is very important that operators and maintenance personnel understand the words and symbols that are used to communicate safety information. Safety words, their meaning and format, have been standardized for U.S. manufacturers and published by the American National Standards Institute (ANSI). The European Community (E.C.) has adopted a different format based on the International Standards Organization (I.S.O.) and applicable machinery directives. Both formats are presented below. Graphic symbols are not standardized but most manufacturers will use some variation of the ones seen in this manual.



Indicates an imminently hazardous situation which, if not avoided, **will** result in death or serious injury.



Indicates a potentially hazardous situation which, if not avoided, **could** result in death or serious injury.



Indicates a potentially hazardous situation which, if not avoided, **may** result in minor or moderate injury and/or property damage.



Provides additional information that the operator needs to be aware of to avoid a potentially hazardous situation.



**Mandatory Lockout Power Symbol.** Disconnect, lockout and tagout electrical and other energy sources before inspecting, cleaning or performing maintenance on this panel.



**International Safety Alert Symbol.** The exclamation point (!) surrounded by a yellow triangle indicates that an injury hazard exists. However, it does not indicate the seriousness of potential injury. The exclamation point (!) is also used with the DANGER, WARNING and CAUTION symbols so the potential injury is indicated.



**Electrocution Hazard Symbol.** This symbol indicates that an electrocution hazard exists. Serious injury or death could result from contacting high voltage.



**International Electrocution Hazard.** This symbol indicates that an electrocution hazard exists. Serious injury or death could result from contacting high voltage.



**Mandatory Read Manual Action Symbol.** (I.S.O. format) This symbol instructs personnel to read the Operators Manual before servicing or operating the equipment.



**Mandatory Read Manual Action Symbol.** This symbol instructs personnel to read the Operators Manual before servicing or operating the equipment.

Notice is used to notify people of important installation, operation or maintenance information which is not hazard related.

**NOTICE**

## **LOCKOUT / TAGOUT PROCEDURES**

Lockout/Tagout is the placement of a lock/tag on an energy isolating device in accordance with an established procedure. When taking equipment out of service to perform maintenance or repair work, always follow the lockout/tagout procedures as outlined in OSHA Standard 1910.147. This standard “requires employers to establish a program and utilize procedures for affixing appropriate lockout devices or tagout devices to energy isolating devices and to otherwise disable machines or equipment to prevent unexpected energizing, start-up, or release of stored energy in order to prevent injury to employees.”

## **CONTROLLED STOP**

This is the stopping of machine motion by reducing the electrical command signal to 0 (zero) once the stop signal has been recognized.

## **HAZARD REVIEW**

### **Electrocution Hazard**



Electrocution accidents are most likely to occur during maintenance of the electrical system or when working on or near exposed high voltage wiring. This hazard does not exist when the electrical power has been disconnected, properly locked, and tagged out.

### **Automatic Start Hazard**



This equipment may be controlled by an automated system and may start without warning. Failure to properly disconnect, lockout, and tagout all energy sources of remotely controlled equipment creates a very hazardous situation and could cause injury or even death. PLEASE STAY CLEAR AND BE ALERT.



## Open Top Field Loader

**YOU** are responsible for the **SAFE** operation and maintenance of your USC, LLC equipment . **YOU** must ensure that you and anyone else who is going to operate, maintain or work around the equipment be familiar with the operating and maintenance procedures and related **SAFETY** information contained in this manual. This manual will take you step-by-step through your working day and alert you to good safety practices that should be adhered to while operating the equipment

Remember, **YOU** are the key to safety. Good safety practices not only protect you, but also the people around you. Make these practices a working part of your safety program. Be certain that **EVERYONE** operating this equipment is familiar with the recommended operating and maintenance procedures and follows all the safety precautions. Most accidents can be prevented. Do not risk injury or death by ignoring good safety practices.

- Equipment owners must give operating instructions to operators or employees before allowing them to operate the machine, and at least annually thereafter per OSHA (Occupational Safety and Health Administration) regulation 1928.57.
- The most important safety device on this equipment is a **SAFE** operator. It is the operator's responsibility to read and understand **ALL** Safety and Operating instructions in the manual and to follow them. All accidents can be avoided.
- A person who has not read and understood all operating and safety instructions is not qualified to operate the machine. An untrained operator exposes himself and bystanders to possible serious injury or death.
- Do not modify the equipment in any way. Unauthorized modification may impair the function and/or safety and could affect the life of the equipment.
- Think **SAFETY!** Work **SAFELY!**

### GENERAL SAFETY

1. Read and understand the operator's manual and all safety labels before operating, maintaining, adjusting or unplugging the equipment .
2. Only trained persons shall operate the equipment . An untrained operator is not qualified to operate the machine.
3. Have a first-aid kit available for use should the need arise, and know how to use it.

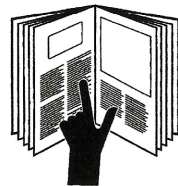

## Open Top Field Loader

4. Provide a fire extinguisher for use in case of an accident. Store in a highly visible place.

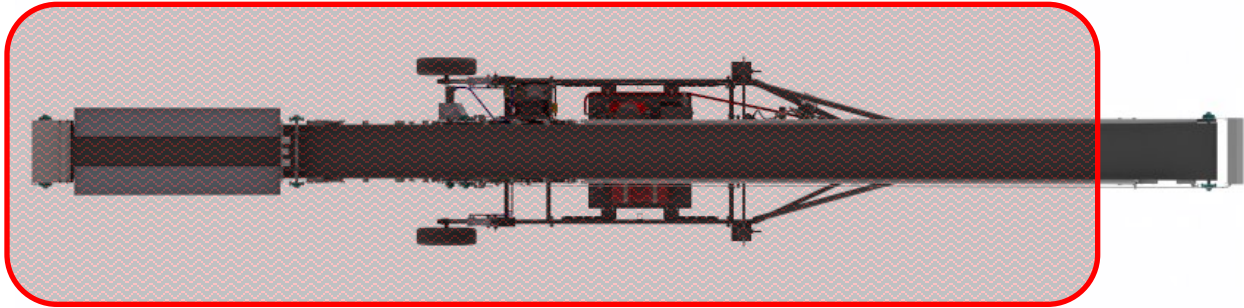
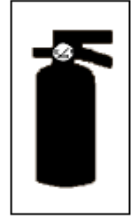

5. Do not allow children, spectators or bystanders within hazard area of machine.
6. Wear appropriate protective gear. This includes but is not limited to:

- A hard hat
- Protective shoes with slip resistant soles
- Protective goggles
- Heavy gloves
- Hearing protection
- Respirator or filter mask



7. Place all controls in neutral or off, stop motor, and wait for all moving parts to stop. Then disable power source before servicing, adjusting, repairing, or unplugging.
8. Review safety related items annually with all personnel who will be operating or maintaining the equipment.





## Open Top Field Loader

1. Pinch points and crush points. Keep body parts and clothing out of these areas while the equipment is moving.
2. Exposed belt. Do not reach under the conveyor while it is running. Stop the conveyor prior to coming within 2 feet of the bottom of the conveyor. Do not walk under the conveyor while running.
3. Entrapment Hazard. The moving belt can drag clothing, or body parts into

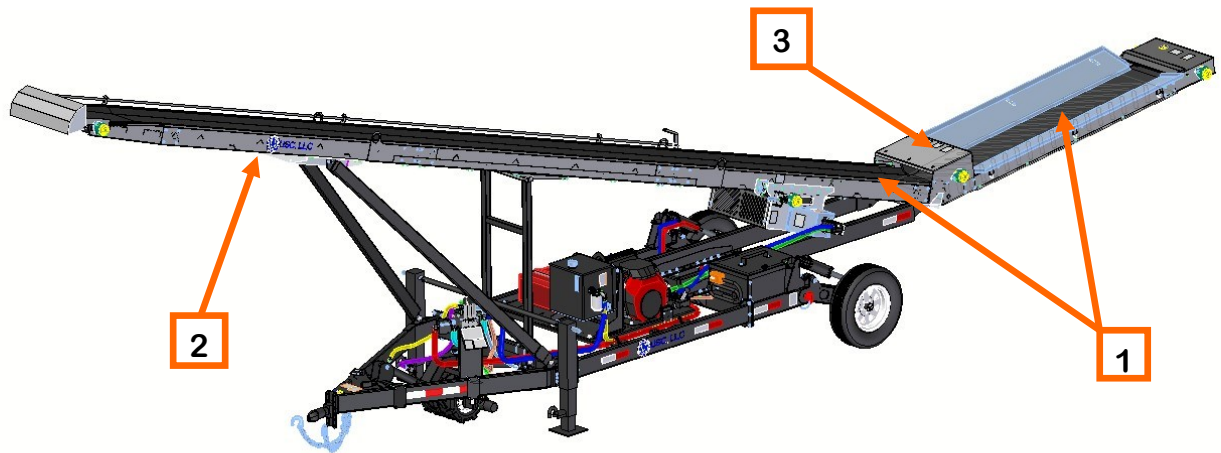

### **OPERATING SAFETY:**

1. Read and understand the operator's manual and all safety labels before using.
2. Disconnect and disable electrical supply completely and wait for all moving parts to stop before servicing, adjusting, repairing or unplugging.
3. Clear the area of bystanders, especially children, before starting.
4. Be familiar with the machine hazard area. If anyone enters hazard area, shut down machine immediately. Clear the area before restarting.
5. Keep hands, feet, hair and clothing away from all moving and/or rotating parts.
6. Stay away from overhead obstructions and power lines during operation and transporting. Electrocution can occur without direct contact.
7. Do not operate machine when any guards are removed.
8. Inspect welds and repair if needed.

**TRANSPORT SAFETY**

1. Read and understand ALL the information in the operator's manuals regarding procedures and SAFETY when moving or transporting the conveyor.
2. Check with local authorities regarding conveyor transport on public roads. Obey all applicable laws and regulations.
3. Always travel at a safe speed. Use caution when making corners or meeting traffic.
4. Make sure the SMV (Slow Moving Vehicle) emblem and all the lights and reflectors that are required by the local highway and transport authorities are in place, are clean and can be seen clearly by all overtaking and oncoming traffic.
5. Do not allow riders on the conveyor or the towing vehicle when transporting.
6. Attach trailer style conveyor to towing vehicle with a 2 5/16 inch ball.
7. Keep to the right and yield the right-of-way to allow faster traffic to pass. Drive on the road shoulder, if permitted by law.
8. Do not exceed 25 m.p.h. (40 km/h). Reduce speed on rough roads and surfaces.
9. Stay away from overhead obstructions and power lines when transporting. Electrocutation can occur without direct contact.
10. Always use hazard warning flashers on tractor when transporting unless prohibited by law.

### **PLACEMENT SAFETY**

1. Move only with the appropriate equipment
2. Stay away from overhead power lines when moving the conveyor. Electrocutation can occur without direct contact.
3. Be familiar with machine hazard area. If anyone enters hazard areas, shut down machine immediately. Clear the area before restarting.
4. Operate the conveyor on level ground free of debris. Anchor the conveyor to prevent tipping or upending.

### **TIRE SAFETY**

1. Failure to follow proper procedures when mounting a tire on a wheel or rim can produce an explosion which may result in serious injury or death.
2. Do not attempt to mount a tire unless you have the proper equipment and experience to do the job.
3. Have a qualified tire dealer or repair service perform required tire maintenance.
4. When replacing worn tires, make sure they meet the original tire specifications. Never undersize.



Before placement of the conveyor, be sure that ground is reasonably level. The conveyor may topple or work improperly if the ground is too uneven, damaging the equipment and/or causing personal injury.



When releasing the conveyor from the towing vehicle, test the intake end for downward weight. Do not raise the intake end above drawbar height. When the intake end is elevated too high with machine in raise position, the balance of weight quickly transfers to the discharge end.

**MAINTENANCE SAFETY**

1. Review the operator's manual and all safety items before working with, maintaining or operating the equipment.
2. Place all controls in neutral or off, stop motors, disable power source, and wait for all moving parts to stop before servicing, adjusting, repairing or unplugging.
3. Follow good shop practices:  
Keep service area clean and dry.  
Be sure electrical outlets and tools are properly grounded.  
Use adequate light for the job at hand.
4. Keep hands, feet, hair and clothing away from all moving and/or rotating parts.
5. Clear the area of bystanders, especially children, when carrying out any maintenance and repairs or making any adjustments.
6. Before resuming work, install and secure all guards when maintenance work is completed.
7. Keep safety signs clean. Replace any sign that is damaged or not clearly visible.



## **SAFETY LABELS**

1. Keep safety labels clean and legible at all times.
2. Replace safety labels that are missing or have become illegible.
3. Replaced parts that displayed a safety label should also display the current label.
4. Replacement safety labels are available. Contact your authorized dealer.

### **How to Install Safety Labels:**

- Be sure that the installation area is clean and dry.
- Be sure temperature is above 50°F (10°C).
- Decide on the exact position before you remove the backing paper.
- Remove the smallest portion of the split backing paper.
- Align the sign over the specified area and carefully press the small portion with the exposed sticky backing in place.
- Slowly peel back the remaining paper and carefully smooth the remaining portion of the sign in place.
- Small air pockets can be pierced with a pin and smoothed out using the piece of sign backing paper.



Located on the USC equipment you will find safety labels. Always be sure to read and follow all directions on the labels.



Guards provided with USC equipment are to remain in place during operation.

## Open Top Field Loader

Think **SAFETY!** Work **SAFELY!**

REMEMBER—If safety labels have been damaged, removed, become illegible, or parts replaced without safety labels, new labels must be applied. New safety labels are available from your authorized dealer. Part #'s located under labels in manual.



09-02-0027



09-02-0006



09-02-0029

Open Top Field Loader

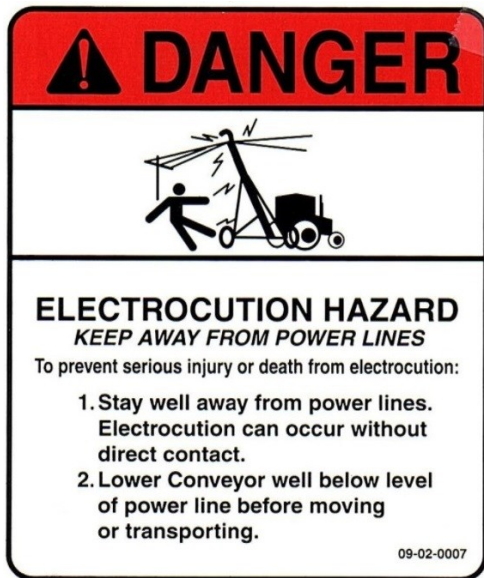

9-02-0007



09-01-0244

Open Top Field Loader



09-02-0031



09-01-0003



Open Top Field Loader



**SAFE OPERATING INSTRUCTIONS**

Make certain everyone is clear of area before operating or moving conveyor.

Disconnect power before resetting motor overload.

Be sure electric motors are grounded.

Support discharge end or anchor intake end to prevent upending.

Empty conveyor before moving to prevent upending.

Lower conveyor to its fully down position before moving or transporting. Use a tractor to move and transport.

USC 785-431-7900 DC-2471

09-02-0032

**DANGER**

Contact with overhead power lines can result in electrocution.

DO NOT allow conveyor to make contact with or come close to power lines. Electrocution can occur without direct contact.

Lower conveyor well below level of power lines before moving or transporting.

USC 785-431-7900 DC-2467

09-02-0028

Open Top Field Loader



<b>WARNING</b>	
<b>CRUSHING HAZARD</b>	
<p>Conveyor frame can crush or entrap when lowered into operating position. Serious injury to hand or foot can result.</p> <p>Do not place hand or foot under conveyor frame while lowering conveyor into operating position.</p> <p>Stay clear of conveyor frame while lowering.</p>	
<small>DC-xxxx</small>	

09-02-0034

<b>WARNING</b>	
<b>SKIN INJECTION HAZARD</b>	
<p>Hydraulic Fluid under pressure can escape from hoses and connections. Fluid under pressure can puncture skin causing serious injury or death.</p> <p>Do not use fingers or hands to check for leaks. Do not hold hose or couplers while operating the pump.</p> <p>Ensure all couplers are properly tightened before operation. Release hydraulic pressure before disconnecting couplers. Wear eye and hand protection at all times.</p>	
<small>DC-2486</small>	

09-02-0033

# MECHANICAL OPERATION

## SECTION B



### OPERATING SAFETY

1. Read and understand the Operator's Manual and all safety signs before using.
2. Electric motor drives: Disconnect and disable electrical supply completely and wait for all moving parts to stop before servicing, adjusting, repairing or unplugging.
3. Clear the area of bystanders, especially children, before starting.
4. Be familiar with machine hazard area. If anyone enters hazard areas, shut down machine immediately. Clear the area before restarting.
5. Keep hands, feet, hair and clothing away from all moving and/or rotating parts.
6. Do not allow riders on the Conveyor or transport vehicle when transporting.
7. Stay away from overhead obstructions and power lines during operation and transporting. Electro-cution can occur without direct contact.
8. Do not operate machine when any guards are removed.
9. Lower Conveyor to its lowest position before moving or transporting or when not in use.
10. Inspect lift cable before using Conveyor. Replace if frayed or damaged.
11. Make certain lift cable is properly seated in cable pulleys.
12. Be sure that conveyor is empty before raising or lowering.

It is the responsibility of the owner or operator to read this manual and to train all other operators before they start working with the machine. In addition to the design and configuration of equipment, hazard control and accident prevention are dependent upon the awareness, concern, and prudence of personnel involved in the operation, transport, maintenance and storage of equipment or in the use and maintenance of facilities.

### NOTICE

Follow all safety instructions exactly. Safety is everyone's business. By following recommended procedures, a safe working environment is provided for the operator, bystanders and the area around the worksite. Untrained operators are not qualified to operate the machine.

Many features incorporated into this machine are the result of suggestions made by customers like you. Read this manual carefully to learn how to operate the machine safely and how to set it to provide maximum efficiency. By following the operating instructions in conjunction with a good maintenance program, your conveyor will provide many years of trouble free service.

## **PRE-OPERATION CHECKLIST**

Efficient and safe operation of the Open Top Field Loader Conveyor requires that each operator reads and understands the operating procedures and all related safety precautions outlined in this section. A pre-operation checklist is provided for the operator. It is important for both the personal safety and maintaining the good mechanical condition of the Conveyor that this checklist is followed.

Before operating the Conveyor and each time thereafter, the following areas should be checked off:

1. Service the machine per the schedule outlined in Section C, Maintenance (see page 35).
2. Check that all guards are installed, secured and functioning as intended. Do not operate with missing or damaged shields.
3. Check worksite. Clean up working area to prevent slipping or tripping.
4. Check that belt is not frayed or damaged and that it is properly adjusted and aligned.
5. Check that discharge chute is free of obstructions.

## **OPERATING HINTS**

- Always listen for any unusual sounds or noises. If any are heard, stop the machine and determine the source. Correct the problem before resuming work.
- Never allow anyone into the workplace hazard area. If anyone enters, stop immediately.
- Do not run the machine for long periods of time with no material on the belt. It increases the wear. Try to run the conveyor only when moving material.
- Always check and make sure the belt is properly aligned. Neglecting your belt may lead to wear and possible breakage.
- Always disconnect power from the conveyor when its not being operated in case of power surges.

## **EMERGENCY STOPPING**

Although it is recommended that the machine be emptied before stopping, in an emergency situation, stop or shutdown the power source immediately. Correct the emergency before resuming work.

## **RESTARTING**

When the machine is shut down inadvertently or for an emergency, the belt may still be covered with material. It may be necessary to tighten the drive belt slightly to handle the heavier-than-normal starting loads.

## **MACHINE BREAK-IN**

Although there are no operational restrictions on the conveyor when used for the first time, it is recommended that the following mechanical items be checked:

### **Before Starting**

1. Read the Conveyor Operator's Manual.
2. During the conveyors first few minutes of operation, check conveyor belt alignment to ensure belt is tracking correctly when running empty and also during loaded conditions.
3. Check that all safety decals are installed and legible. Apply new decals if required.

### **After Operating for 1/2 Hour**

1. Re-torque fasteners and hardware.
2. Check the conveying belt tension and alignment. Tension or align as required.
3. Check that all guards are installed and working as intended.

### **After Operating for 5 Hours and 10 Hours**

1. Re-torque all bolts, fasteners and hardware.
2. Check that all guards are installed, secured and functioning as intended. Do not operate with missing or damaged shields.
3. Check safety decals. Install new ones if required.
4. Check the belt, belt tension, and alignment. Tension or align as required.
5. Then go to the normal servicing and maintenance schedule as defined in the Maintenance Section.

**OPEN TOP FIELD LOADER CONVEYOR OVERVIEW**

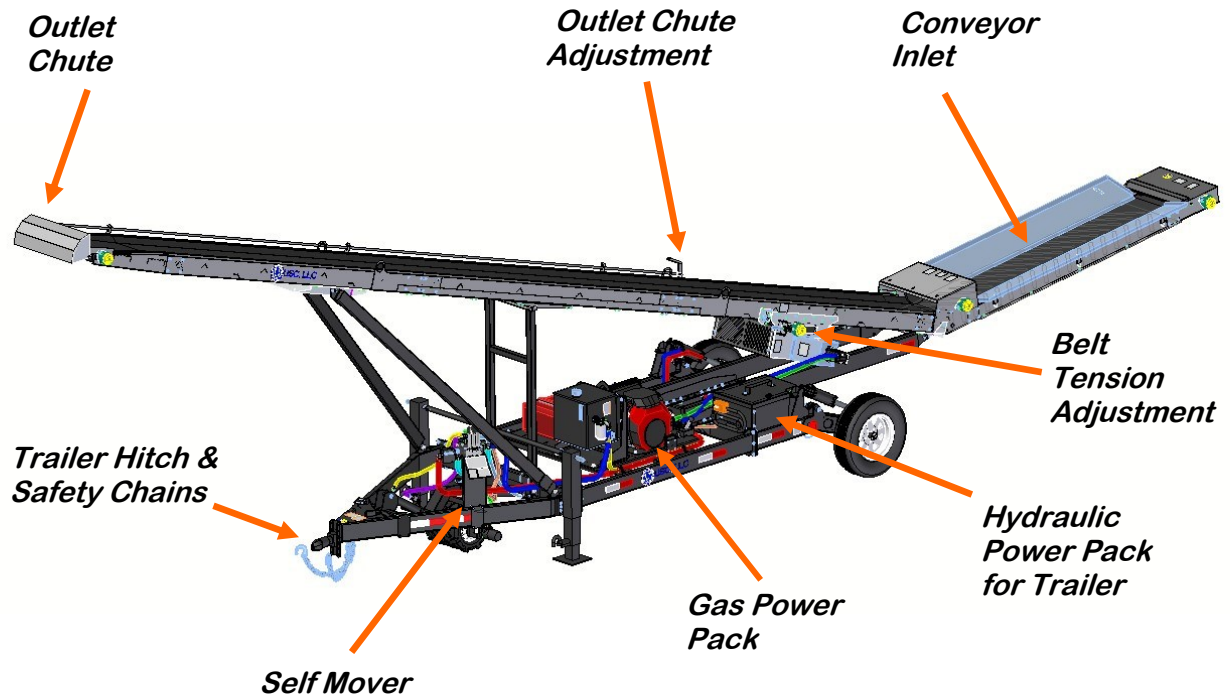

## **CONVEYOR WITH TRAILER OPERATION**

1. Remove red pins (1 each side) from the axle pivots. Position A is the storage position for the pins. Position B is the locked position.
2. Using either the hardwired or remote hydraulic control, lower the conveyor to the ground. (C) up, (D) down.
3. Maneuver the conveyor inlet under the grain source (bin, field cart, truck, etc. This can be done with the towing vehicle of the self mover on the conveyor.
4. Disconnect conveyor from towing vehicle.
5. Verify 14' discharge height will clear receiving vessel (bin, field cart, truck, etc.).
6. If not already started, start gas engine to operate belt. See page 24.
7. Engage belt.
8. Open the grain source gate.
9. When finished, close the grain source gate.
10. Allow all the grain to exit the conveyor and turn off the conveyor.
11. Move conveyor forward to raise conveyor back up.
12. Prior to transport, reinstall the two red pins.
13. Move to next location and repeat.

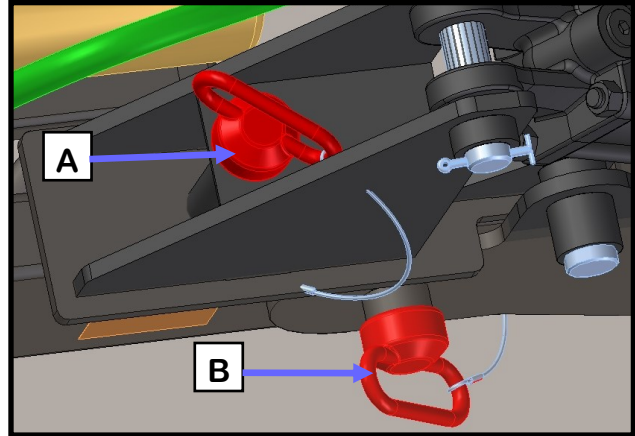

*Lock Pin Locations*

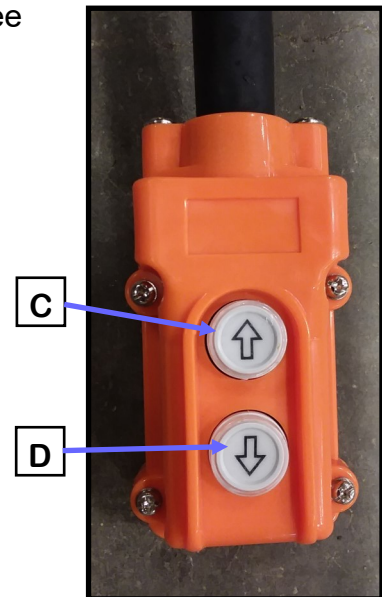

## GAS POWERED HYDRAULIC POWER PACK

**CAUTION** Do not operate machine if temperature is at or below -10 degrees

### PRE-START-UP CHECKS

1. Check around and under the engine for signs of oil or gasoline leaks.
2. Remove any excessive dirt or debris, especially around the muffler.
3. Look for signs of damage.
4. Check that all shields and covers are in place and all nuts, bolts, and screws are tightened.
5. Check the fuel level. Starting with a full tank will help to eliminate or reduce interruptions for refueling.
6. Check engine oil level.
7. Check that the air filter is clean.

**DANGER** DO NOT START ENGINE IN CONFINED SPACE (BARN, ETC).  
The exhaust contains poisonous carbon monoxide gas that can build up to dangerous levels in enclosed areas. Breathing carbon monoxide can cause unconsciousness or death.

### STARTING THE ENGINE

1. Make sure that the conveyor is in the OFF position.

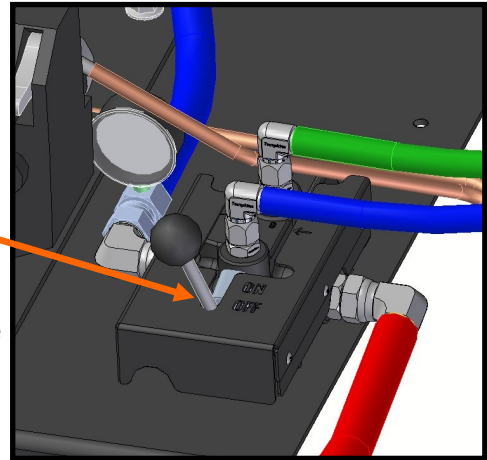

2. The fuel tank is equipped with a shut off valve. Be sure that it is in the open position.

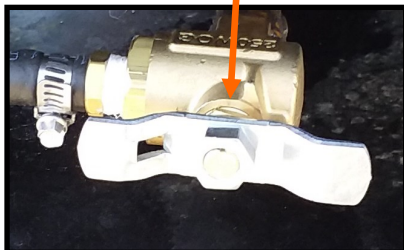

OR





## Open Top Field Loader

3. To start a cold engine, pull the choke knob out to the closed position
4. To start or restart a warm engine, leave the choke knob in to the open position.
5. Move the throttle lever away from the min position, about 1/3 of the way towards the max position.
6. Turn the engine switch to the on position.
7. Operate the starter . Turn the engine switch to the start position and hold it there until the engine starts. If the engine fails to start within 5 seconds, release the engine switch, and wait at least 10 seconds before operating the starter again. ( using the electric starter for more than 5 seconds at a time will overheat the starter motor and damage it.)
8. When the engine starts, release the engine switch, allowing it to return to the on position.
9. Position the throttle lever to the desired speed. It is recommended between half and three-quarters speed.
10. In cold weather it is recommended to warm up the hydraulic fluid. This can be done by running the drive wheels when in the up position. Engage the drive wheels for approximately 10-15 minutes.
11. Move the conveyor control to the on position.
12. Warm up the belt by engaging the belt on low engine speed and let run for 10-15 minutes.

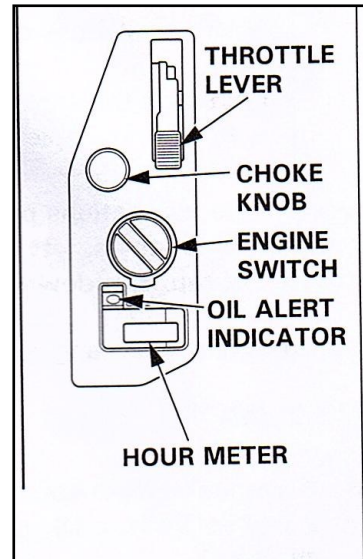

### NOTICE

If the belt does not turn, it could be frozen to tube or inlet pan. To avoid damage to the belt, it is recommended to move the machine to a warm shed/building to ensure the belt isn't frozen in place. Allow time for the machine and components to warm up before attempting to run again.

After the unit is warmed up and the belt still does not turn, check to ensure the conveyor belt is tensioned and aligned. See pages 35-37 of operator's manual for belt alignment and tensioning instructions. Belt alignment and tensioning should be checked weekly.

**STOPPING THE ENGINE**

1. Move the conveyor lever to the OFF position.
2. Move the throttle lever to the min position.
3. Turn the engine switch to the off position.
4. Close the shut off valve on the fuel tank.

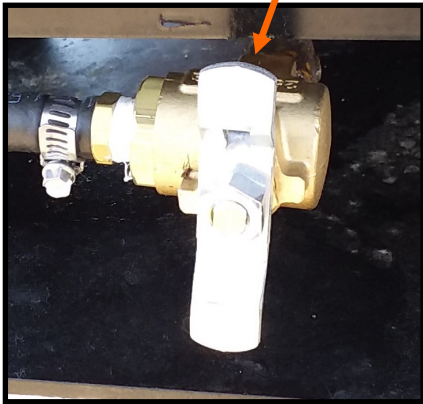



OR

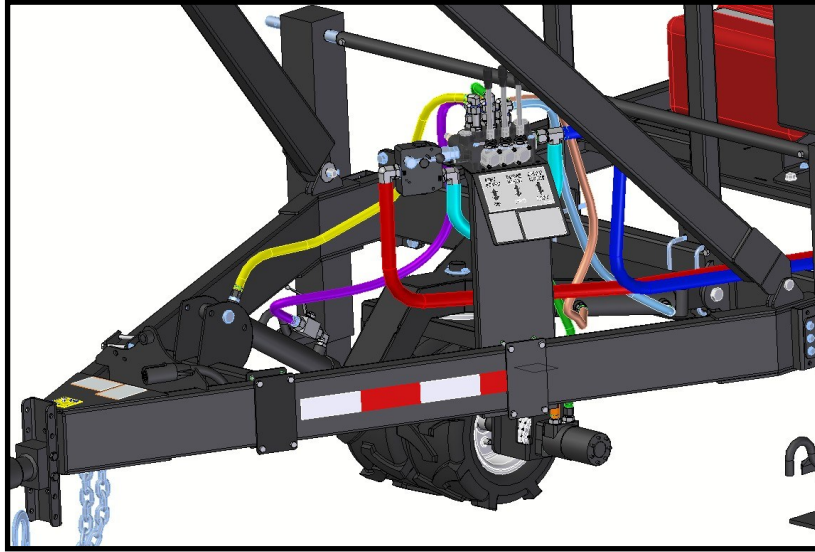

## Open Top Field Loader

### SELF-MOVER



** DANGER** Always clear area of bystanders. In the event anyone enters the danger area, stop and do not proceed until they have left the danger area.

1. **DRIVE UNIT UP / DOWN:** To raise or lower the drive unit use lever 1.
2. **FORWARD / REVERSE CONTROL:** To move the conveyor forward or backward use lever 2.
3. **STEERING CONTROL:** To steer right or left use lever 3.
4. **SPEED CONTROL:** Adjust speed using the lever to the left of the panel. The higher the number the faster the conveyor will move. It is recommended that the conveyor be slowly moved to prevent tipping.

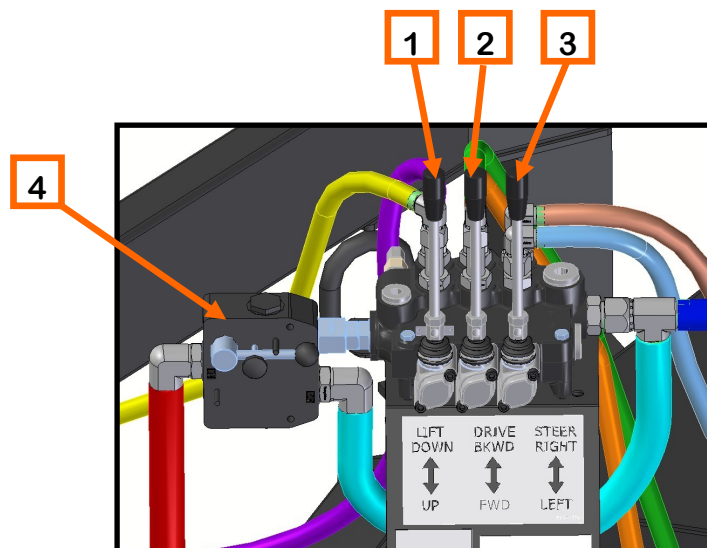

## Open Top Field Loader

### **SELF-MOVER**

1. Start the engine on the hydraulic power pack according to the instructions starting on page 24.
2. Open the valve on the lift cylinder.
3. Lower the drive unit so the jacks come up off the ground



**DANGER**

When moving the unit, the jacks need to be close to the ground to prevent tipping. The conveyor also needs to be resting on the support.

4. Lower and lock the rear wheels. See page 23.

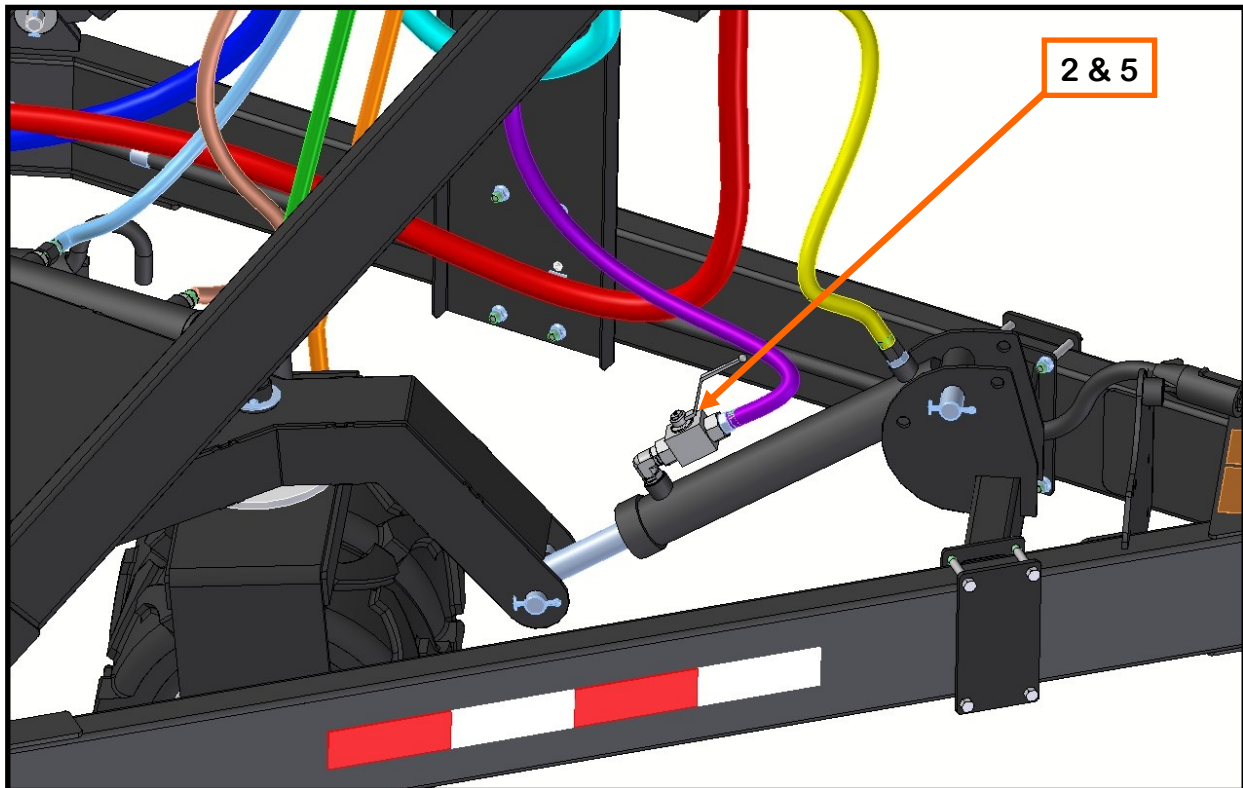

5. To transport the conveyor, raise the drive unit so conveyor is resting on the jacks. Close valve on lift cylinder and shut down the engine.
6. Do not exceed 25 mph on roads. Reduce speed on rough roads and surfaces.
7. Refer to page 10 for Transport Safety.

## **REMOTE HYDRAULIC KIT OPERATION**

### **OPERATION**

1. Depress the on/off button on the transmitter to activate (B). The blue light on the top should turn on. The transmitter has a safety time-out feature. When the unit was active and then not used for 1 minute it will automatically turn off. Just hit the on/off button to turn it back on!
2. On the transmitter depress and hold the UP Button (A) to raise the trailer.
3. Depress and hold the DOWN Button (C) to lower the trailer.
4. The switch mounted on the receiver module will function the same as the transmitter buttons.

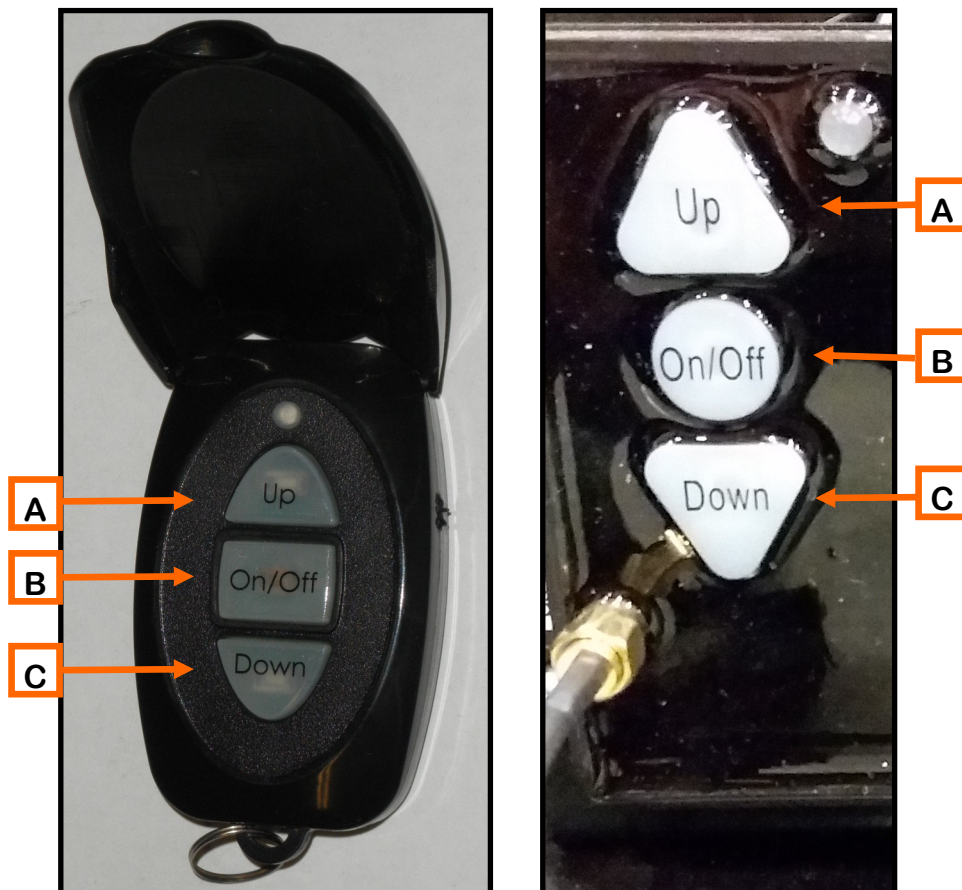

*Remote Transmitter*

*Receiver Module*

## Open Top Field Loader

### How to learn a transmitter

1. Enter the learn mode: Push and hold the on/off button on the Receiver Module (B) until the LED (A) starts to flash. Then release the button (B)
2. Push and hold the on/off button (C) on the transmitter until the LED (A) on the Receiver Module comes on constant.
3. Release the on/off button. The transmitter is now learned.
4. Option: learn another transmitter by repeating steps 1 through 3. Note: the Receiver Module exits the "learn mode" after each transmitter is learned. You can learn up to 8 transmitters.
5. To clear all transmitters out of the Receiver Module: Push and hold the on/off button (B) on the Receiver Module for 10 seconds.
6. Test the remote to insure that up moves trailer up, etc. If not reverse wires blue and gray.

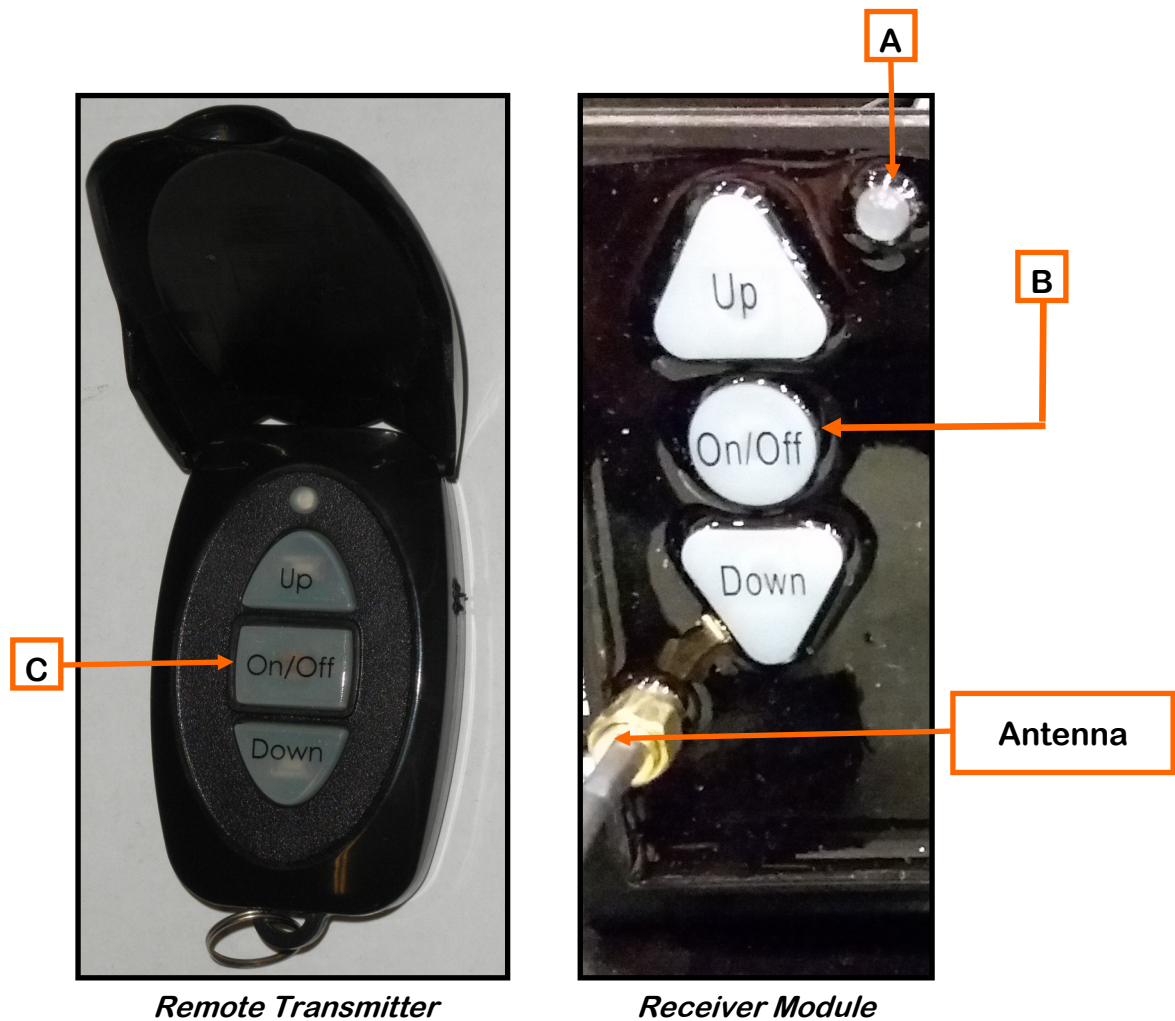

## ADJUSTING & CHECKING HYDRAULIC PRESSURE

If the belt turns but the control valve squeals, the bypass pressure may need to be increased. Follow Instructions below on how to increase pressure.

1. Turn off engine.
2. Remove end cap from belt on/off valve. A small amount of hydraulic fluid may leak out.

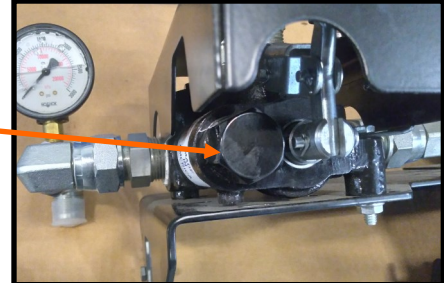

3. Use allen wrench to adjust pressure. Turn screw clock-wise to increase pressure. Increasing the pressure too much could cause the engine to stop.
4. Re-install cap. Turn on engine and engage belt to check for any valve noises.
5. When the control valve stops squealing, operation can begin.

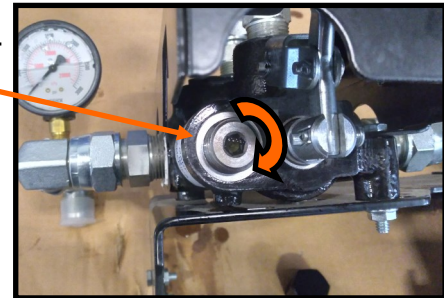

6. To check actual pressure of unit, turn off engine and disconnect lines from valve that run to belt motor. Turn on engine and engage valve to check pressure. Factory setting is approximately 2100 psi.

### NOTICE

The disconnects are not applicable to all model years

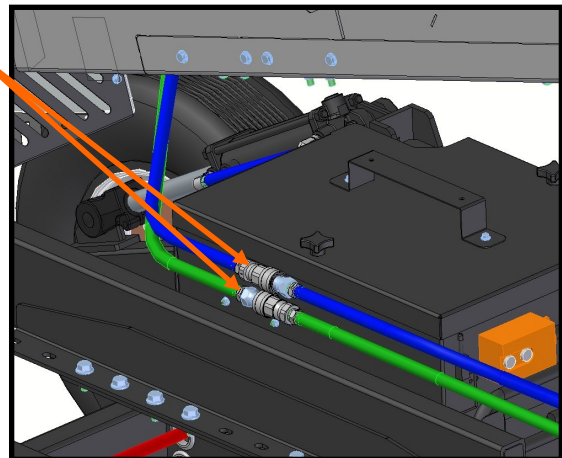

SECTION  
C**TROUBLESHOOTING**

Below is a table describing the most frequent problems and solutions with the Open Top Field Loader Conveyor. For further assistance, contact your authorized dealer.

Problem	Possible Cause	Solution
Belt turns but control valve squeals	1. Bypass pressure may need increased.	1. Increase bypass pressure.
Conveyor will not run.	1. Not turned on. 2. Conveying belt loose. 3. Drive belt loose.	1. Start power source or turn power on. 2. Tighten and align belt. 3. Tighten drive belt.
Drive unit will not raise or lower.	1. Ball valve is in shut off position.	2. Open valve.
Belt edge fraying.	1. Belt not aligned.	1. Align and tension belt.
Low conveying capacity.	1. Conveyor belt slipping. 2. Drive belt slipping.	1. Tighten belt. 2. Set drive belt tension.



**MAINTENANCE****SECTION  
D**

Proper maintenance of the Open Top Field Loader Conveyor is critical for peak performance, reliability, and accuracy of this system. The following is a guideline for the type of maintenance and servicing that should be performed on this unit. Your environment and uses may require additional maintenance and service beyond this list to assure a reliable and safe unit. The operator of this unit has ultimate responsibility to identify areas of concern and rectify them before they become a hazard or safety issue. There is no substitute for a trained, alert operator.



Do not put this unit into operation with any questionably maintained parts. Poor performance or a hazard may occur.



Failure to maintain the proper belt tension will cause the belt to slip. This will damage the belt and drive pulley. If the belt is not tracking correctly, it can ride along one edge causing the belt to fray and damage the belt splice. Either problem will cause the belt to burn or wear out prematurely.

**FLUIDS AND LUBRICANTS****Grease**

Use an SAE multipurpose high temperature grease with extreme pressure (EP) performance. Also acceptable is an SAE multipurpose lithium-based grease.

**Storing Lubricants**

Your machine can operate at top efficiency only if clean lubricants are used. Use clean containers to handle all lubricants. Store them in an area protected from dust, moisture and other contaminants.

**GREASING**

Use a Maintenance Checklist to keep record of all scheduled maintenance.

1. Use a hand-held grease gun for all greasing.
2. Wipe grease fitting with a clean cloth before greasing to avoid injecting dirt and grit.
3. Replace and repair broken fittings immediately.



If fittings will not take grease, remove and clean thoroughly. Also clean lubricant passageway. Replace fitting if necessary.

**CONVEYOR SERVICING INTERVALS**

**Every 40 hours or Weekly**

1. Check the conveyor belt tension and alignment.
2. Grease conveyor bearings.

**Every 100 Hours**

1. Change engine oil and filter. (refer to engine operators manual)

**Every 200 hours or Annually**

1. Wash machine.
2. Check bearings for wear

**Every 2000 hours**

1. Change hydraulic fluid and filter.

## **BELT TENSIONING AND S-DRIVE ALIGNMENT**

A wide chevron belt is used to convey material along the frame. The tension and alignment of the belt should be checked weekly, or more often if required, to be sure that it does not slip or run to one side. A properly tensioned belt will not slip when it is operating. Operating the belt with less slippage will increase the belt life and causes less stress on bearings, pulleys and shafts.

### **⚠ WARNING**

Although it is acceptable to align the belt from either the Head or the Tail end. Tightening the belt may only be done from the Mid-Section of the conveyor

### **NOTICE**

To maintain the belt, follow this procedure:

Place all controls in neutral or off, stop motor, and disable power source before working on belt.

1. If the belt needs to be tightened to prevent slippage, use the take-up adjustments on the mid-section only.
2. Loosen the jam nut closest to the tail prior to making adjustments.
3. To tighten the belt, turn the remaining jam nut clock-wise by an equal number of turns, or employ a tape measure to ensure the tensioner plate's uniform distance from the end of the conveyor belt guard on each side. The tensioner plates should be equally set. The conveyor belt only needs to be tight enough to not slip on the drive roller. If the belt is too loose, it will slip on the drive roller making a noticeable sound, slowing the belt down.
4. Turn the belt 1/2 revolution when the belt is new and check the head and tail roller. If out of alignment, the belt will move to the loose side. Loosen the jam nut and use the bearing position bolts to set the position. Tighten jam nut.
5. Run and check again. Check frequently during the first few minutes of operation and then several times during the first 10 hours. The belt normally seats itself during the first 10 hours of operation and can be checked weekly after that.
6. The belt is properly aligned when the belt runs in the center of the head and tail rollers.

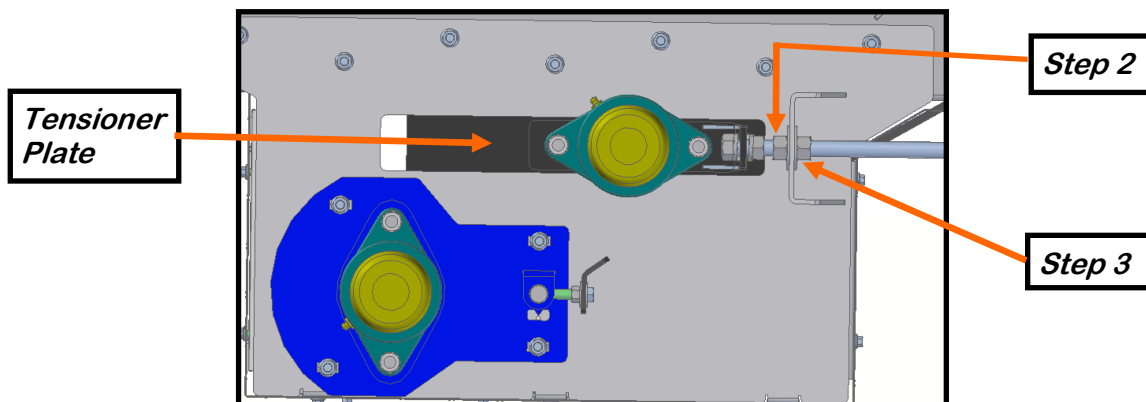

## **CONVEYING BELT ALIGNMENT**

### **Before Aligning the Belt**

1. The conveyor must be empty of all seed.
2. Wait until the belt makes a complete revolution before adjusting the rollers. Some belts may have uneven edges, appearing misaligned.
3. The rear tail cover may need to be removed in order to get a good view of the belt alignment.

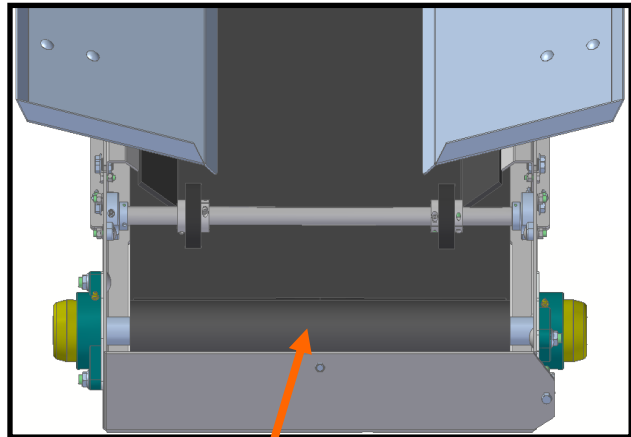

*Rear tail cover removed*

### **Belt Alignment, Head & Tail Rollers**

1. Determine if the belt is out of alignment. Start with the head roller. If belt is tracking toward tensioner as shown in diagram to the right, then adjust tensioner as shown in next steps.

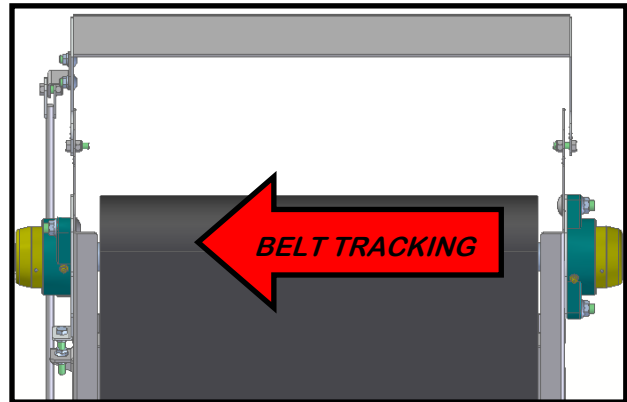

2. Loosen nuts on bearing.

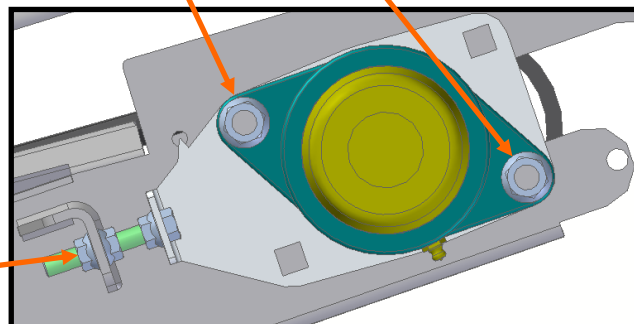

3. Loosen jam nut.

Open Top Field Loader

4. Hold nut with wrench and turn bolt clock-wise to allow belt to track back to center. Rotate nut opposite direction if belt is tracking to the opposite side of the conveyor. Verify proper alignment by ensuring that the bearing position indicator is centered on the hole.

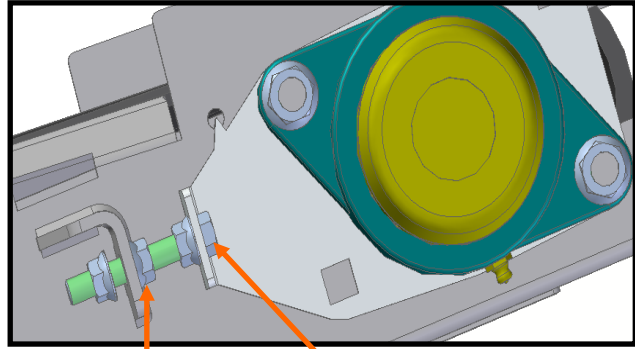

*Alignment Nut*

*Bolt*

5. Next check the alignment at the tail of the conveyor. If belt is tracking toward tensioner as shown in diagram to the right, then adjust tensioner as shown in next steps.

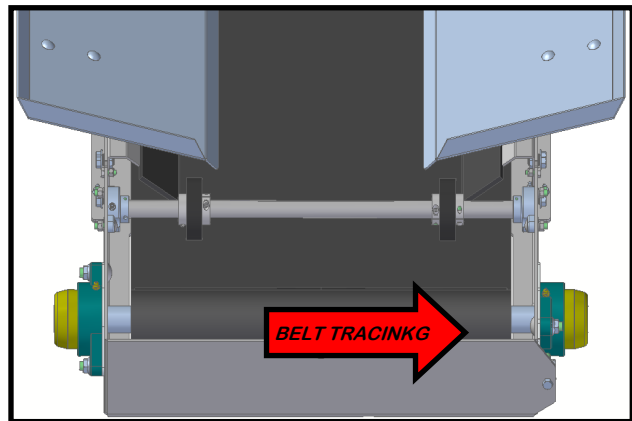

6. Loosen nuts on bearing and jam nut.

7. Hold bolt with wrench and rotate alignment nut clock-wise to allow belt to track back to center. Rotate nut opposite direction if belt is tracking to the opposite side.

8. Check the belt alignment and repeat necessary steps if out of alignment. If belt is aligned and ready for use, replace all covers and retorque all fasteners.

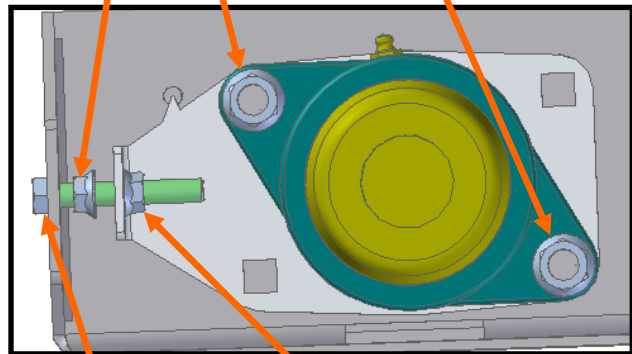

*Bolt*

*Alignment Nut*

## **BELT REPLACEMENT**

1. Rotate the belt until the seam is visible.
2. Move take-up bolts to their loosest position.
3. Pull all the slack to the seam area.
4. Remove the wire connector and open the belt.
5. Attach one end of the replacement belt to the belt end being removed.
6. Pull the old belt out and the new belt will be threaded into place.
7. Disconnect the old belt.
8. Connect the ends of the new belt together and secure.
9. Set the belt tension.
10. Check and set the belt alignment. A good starting place for belt alignment is having the bearing position indicator centered on hole (bottom right). The tail, S-drive, and head all have a bearing position indicator.

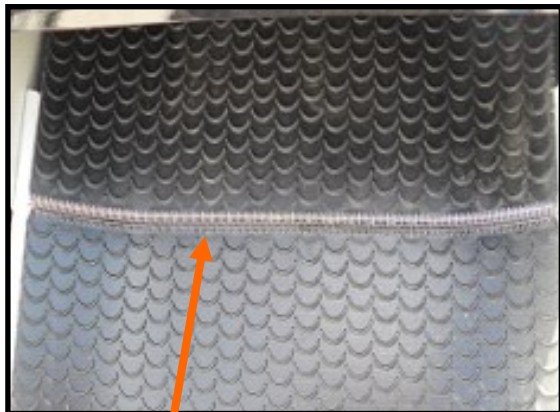

***Belt Seam***

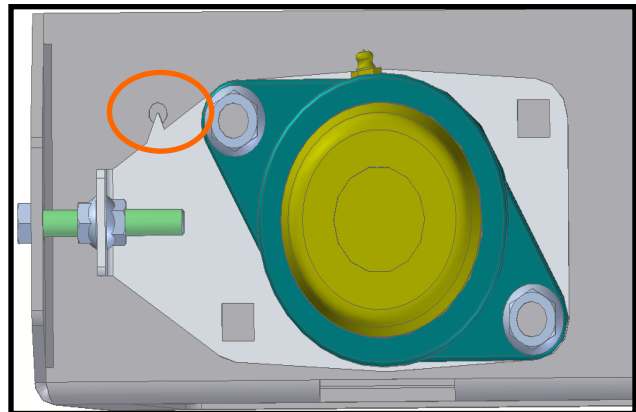

When storing the Open Top Field Loader Conveyor for long periods of time, the following procedure must be followed to reduce the chance of rust, corrosion and fatigue of the conveyor. You can also use these steps when storing the machine for the winter.



A dust mask and protective rubber gloves shall be used when cleaning the machine.

1. Clear the area of bystanders, especially small children.
2. Thoroughly wash the entire machine to remove all dirt, mud, debris or residue.
3. Inspect all moving or rotating parts to see if anything has become entangled in them. Remove the entangled material.
4. Lubricate all grease fittings. Make sure that all grease cavities have been filled with grease to remove any water residue from the washing. This also protects the bearing seals.
5. Remove drive assembly cover. Clean entire area and ensure drive belt is clean and free of debris.
6. Touch up all paint nicks and scratches to prevent rusting.
7. Select an area that is dry, level and free of debris.
8. If possible, store the machine inside a protective building to keep it from being exposed to the weather. If storing outside, cover the entire machine with a large waterproof tarpaulin. If you do not have one large enough, at a minimum cover hydraulic motors.
9. Store machine in an area away from human activity.
10. Do not allow children to play on or around the stored machine.

Open Top Field Loader

**NOTES:**





# USC LIMITED WARRANTY

## SECTION F

### USC, LLC, MANUFACTURER WARRANTY ON SEED TREATING EQUIPMENT

01AUG22

USC, LLC, (Manufacturer) warrants its equipment as follows:

1.Limited Warranty: Manufacturer warrants that the Products sold hereunder will be free from defects in material and workmanship for a period of 18 months from date of shipment by Manufacturer for all seed treating equipment and a period of 12 months from date of shipment by Manufacturer for all grain and fertilizer handling equipment.

If the Products do not conform to this Limited Warranty during the warranty period, Buyer shall notify Manufacturer in writing (on the approved USC warranty claim form) of the claimed defects and demonstrate to Manufacturer satisfaction that said defects are covered by this Limited Warranty (through pictures, video or other objective data). If the defects are properly reported to Manufacturer within the warranty period, and the defects are of such type and nature as to be covered by this warranty, Manufacturer shall, at its expense, furnish replacement Products or, at Manufacturer's option, replacement parts for the defective products. Shipping and installation of the replacement Products or replacement parts shall be at the Buyer's expense.

All replacement parts orders through Manufacturer will carry their specific manufacturer's standard warranty. There is no warranty on replacement parts manufactured by Manufacturer. Manufacturer will not extend any warranty due to replaced parts. The end user is responsible for all shipping and handling expenses for parts returned to Manufacturer under this section which may or may not be included in that specific warranty. Manufacturer will pay shipping expense between USC and its vendor.

2.Other Limits: THE FOREGOING IS IN LIEU OF ALL OTHER WARRANTIES, EXPRESSED OR IMPLIED, INCLUDING BUT NOT LIMITED TO THE IMPLIED WARRANTIES OF MERCHANTABILITY AND FITNESS FOR A

PARTICULAR PURPOSE. Manufacturer does not warrant against damages or defects arising from improper installation (where installation is by persons other than Manufacturer), against defects in products or components not manufactured by Manufacturer, or against damages resulting from such non-Manufacturer made products or components. Manufacturer passes on to the Buyer the warranty it received (if any) from the maker of such non-Manufacturer made products or components. This warranty also does not apply to Products upon which repairs and / or modifications have been affected or attempted by persons other than pursuant to written authorization by Manufacturer. This includes any welding on equipment which could damage electrical components. Manufacturer does not warrant against injuries or damages resulting from misuse and / or abuse of Products, improper storage or handling, acts of nature, effects of weather, including effects of weather due to outside storage, accidents, or damages incurred during transportation by common carrier or Dealer/customer arranged freight. Any replacement or repair covered under this warranty will not extend the warranty period. The remainder of the manufacturer's warranty will remain in force until stated expiration.

3.Exclusive Obligation: THIS WARRANTY IS EXCLUSIVE. The sole and exclusive obligation of Manufacturer shall be to repair or replace the defective Products in the manner and for the period provided above. Manufacturer shall not have any other obligation with respect to the Products or any part thereof, whether based on contract, tort, strict liability or otherwise. Under no circumstances, whether based on this Limited Warranty or otherwise, shall Manufacturer be liable for lost profits, lost revenue, lost sales (whether direct or indirect damages), incidental, special, punitive, indirect or consequential damages. Buyer shall make no claims for renumeration for any loss as a result of USC equipment and USC shall reject any and all claims that may arise as stated herein.

4.Other Statements: Manufacturer's employees or representatives' oral or other written statements do not constitute warranties, shall not be relied upon by Buyer, and are not a part of the contract for sale or this limited warranty. The USC Warranty Manager is the final decision point for all warranty claims.

5.Return Policy: Approval is required prior to returning goods to Manufacturer irrespective of warranty claim. Manufacturer may give a credit, less a 15% restocking fee, for goods that are returned in new, sellable condition. Items returned for warranty that are found to be not covered by the warranty will remain the property of the Buyer. The Buyer will have the ability to have part returned at their expense or, if in new, sellable condition, receive a credit less a 15% restocking fee and less any USC paid freight for its return.

6.Entire Obligation: This Limited Warranty states the entire obligation of Manufacturer with respect to the Products. If any part of this Limited Warranty is determined to be void or illegal, the remainder shall remain in full force and effect. Other terms included in Manufacturer's Terms of Sale will also apply.

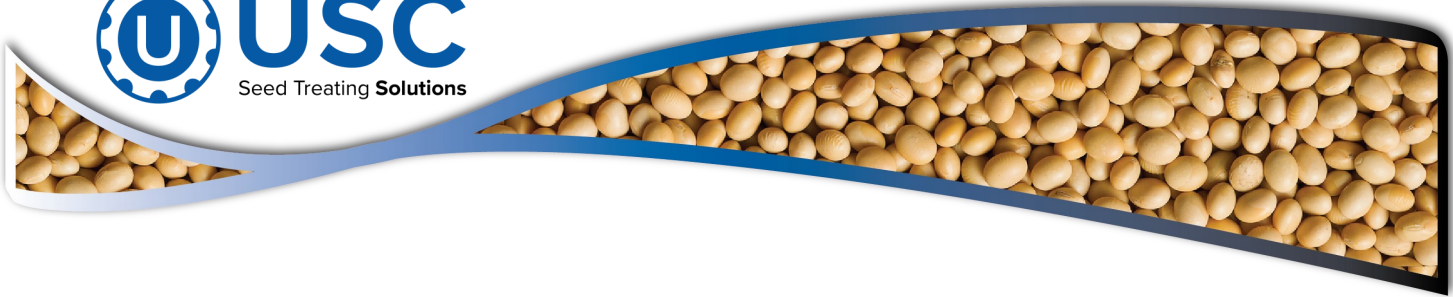

DOCUMENT REVIEW RECORD	
DATE	BY
10/26/23	PWB

**USC, LLC**

2320 124th Road

Sabetha, KS 66534

PHONE: (785) 431-7900

EMAIL: [sales-team@uscllc.com](mailto:sales-team@uscllc.com)

WEB: [www.uscllc.com](http://www.uscllc.com)

