

AUTOMATED LIW LOCK AND LOAD DRY ADDITIVE FEEDER

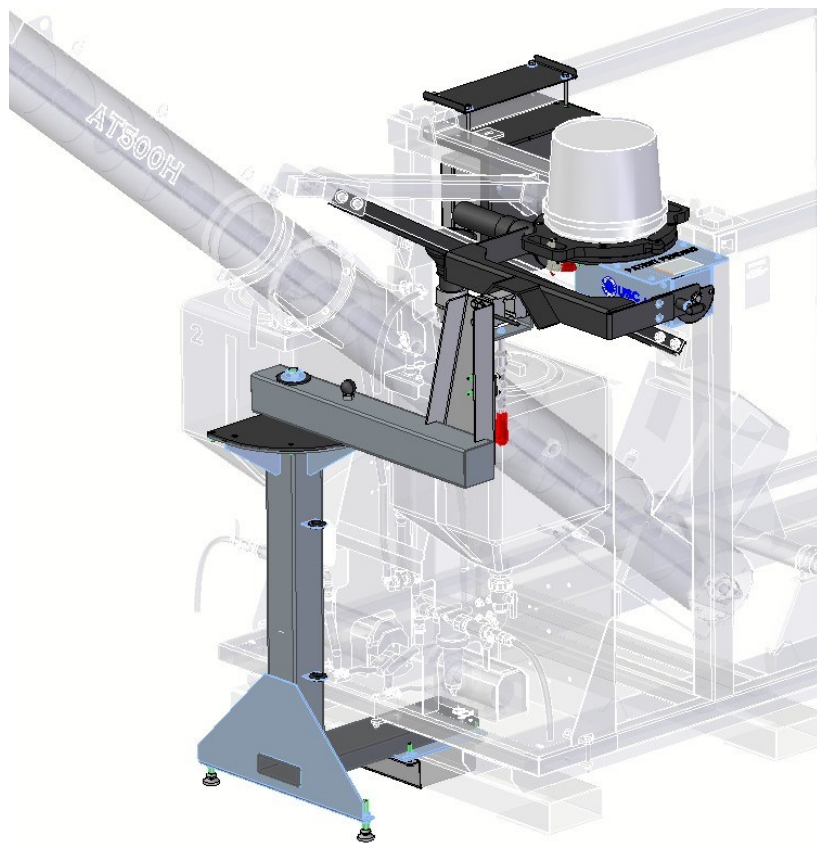

OPERATOR'S MANUAL

Document: TD-09-06-1081

Revision: A

Effective Date: Jan 2024

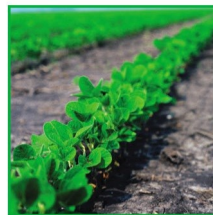

INTRODUCTION

Thank you for choosing USC, LLC for your equipment needs. We appreciate your business and will work diligently to ensure that you are satisfied with your choice.

OVERVIEW

The purpose of this manual is to provide you with the basic information needed to operate and maintain the Dry Additive Feeder. It does not hold USC, LLC liable for any accidents or injuries that may occur.

The technical information provided in this document is based on extensive testing under controlled conditions at the USC research and development facility. This information is given without guarantee as the conditions of operation and storage of the equipment are beyond our control. Variables such as temperature, humidity, viscosity of chemical products and changes in seed size or variety may all effect the accuracy of application and seed coverage. Periodically check the equipment calibration while treating and make adjustments as required. This will insure the optimum seed coverage.

OPERATOR RESPONSIBILITIES

As the purchaser/owner/operator of this equipment and control system, you have an obligation to install, operate, and maintain the equipment in a manner that minimizes the exposure of people in your care to any potential hazards inherent in using this equipment. It is critical that the owner of this equipment:

- Has a clear and documented understanding of the process this machine is being used in and of any resulting hazards or special requirements arising from this specific application.
- Allow only properly trained and instructed personnel to install, operate or service this equipment.
- Maintain a comprehensive safety program involving all who work with this machine and other associated process equipment.
- Establish clear areas of staff responsibility (e.g. operation, setup, sanitation, maintenance, and repairs).
- Provide all personnel with necessary safety equipment.
- Periodically inspect the equipment to insure that the doors, covers, guards, and safety devices are in place and functioning, that all safety instructions and warning labels are intact and legible, and that the equipment is in good working order.
- In addition to the operating instructions, observe and enforce the applicable legal and other binding regulations, national and local codes.

LIW Dry Additive Feeder

As the person with the most to gain or lose from working safely, it is important that you work responsibly and stay alert. By following a few simple rules, you can prevent an accident that could injure or kill you or a co-worker.

- Disconnect, lockout, and tagout electrical and all other energy sources before inspecting, cleaning, servicing, repairing, or any other activity that would expose you to the hazards of electrical shock.
- Do not operate, clean, or service this equipment until you have read and understood the contents of this manual. If you do not understand the information in this manual, bring it to the attention of your supervisor, or call USC at (785) 431-7900 for assistance.
- Any operator who is known or suspected to be under the influence of alcohol or drugs should not be allowed to operate the equipment.
- Understand and follow the safety practices required by your employer and this manual.
- **PAY ATTENTION** to what you and other personnel are doing and how these activities may affect your safety.
- **Failure to follow these instructions may result in serious personal injury or death.**

RECEIVING YOUR EQUIPMENT

As soon as the equipment is received, it should be carefully inspected to make certain that it has sustained no damage during shipment and that all items listed on the packing list are accounted for. If there is any damage or shortages, the purchaser must immediately notify USC, LLC. Ownership passes to purchaser when the unit leaves the USC, LLC. premises. The purchaser is responsible for unloading and mounting all components of the equipment.

Document the serial number of the machine for future reference. The serialization label is located on the back side of the unit.

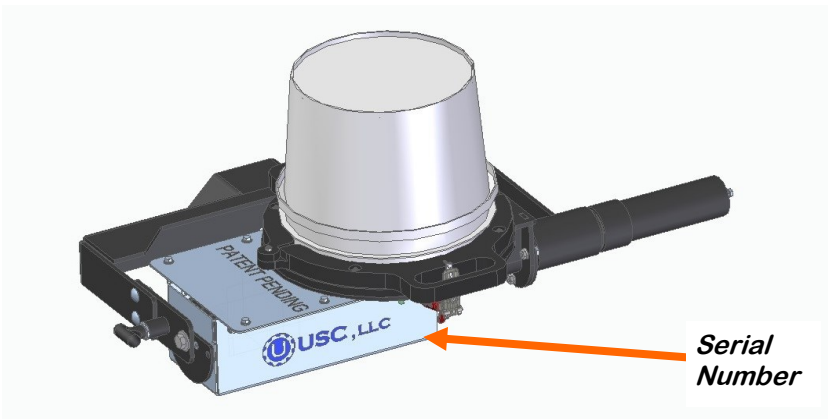

Example



SERIAL NUMBER: _____

TABLE OF CONTENTS

<u>Section</u>	<u>Contents</u>	<u>Page #</u>
Section A	Safety Instructions	5
Section B	Installation	15
	Installation on AT500.....	16
Section C	Mechanical Operation	19
	System Overview	19
	Bucket Installation	20
	Transporting	22
Section D	Calibration	23
	Load Cell Calibration.....	23
	LIW DAF Calibration.....	25
Section E	Troubleshooting	26
Section F	Maintenance	27
	Bearings and gears.....	27
	Supply hopper, Electrical Panel.....	28
Section G	Storage.....	29
Section H	Limited Warranty	31

SAFETY INSTRUCTIONS

SECTION A

Every year accidents in the work place maim, kill, and injure people. Although it may be impossible to prevent all accidents, with the right combination of training, operating practices, safety devices, and operator vigilance, the number of accidents can be significantly reduced. The purpose of this section is to educate equipment users about hazards, unsafe practices, and recommended hazard avoidance techniques.

SAFETY WORDS AND SYMBOLS

It is very important that operators and maintenance personnel understand the words and symbols that are used to communicate safety information. Safety words, their meaning and format, have been standardized for U.S. manufacturers and published by the American National Standards Institute (ANSI). The European Community (E.C.) has adopted a different format based on the International Standards Organization (I.S.O.) and applicable machinery directives. Both formats are presented below. Graphic symbols are not standardized, but most manufacturers will use some variation of the ones seen in this manual.



Indicates an imminently hazardous situation which, if not avoided, **will** result in death or serious injury.



Indicates a potentially hazardous situation which, if not avoided, **could** result in death or serious injury.



Indicates a potentially hazardous situation which, if not avoided, **may** result in minor or moderate injury and/or property damage.



Provides additional information that the operator needs to be aware of to avoid a potentially hazardous situation.



Mandatory Lockout Power Symbol. Disconnect, lockout and tag-out electrical and other energy sources before inspecting, cleaning or performing maintenance on this panel.



International Safety Alert Symbol. The exclamation point (!) surrounded by a yellow triangle indicates that an injury hazard exists. However, it does not indicate the seriousness of potential injury. The exclamation point (!) is also used with the DANGER, WARNING and CAUTION symbols so the potential injury is indicated.



Electrocution Hazard Symbol. This symbol indicates that an electrocution hazard exists. Serious injury or death could result from contacting high voltage.



International Electrocution Hazard. This symbol indicates that an electrocution hazard exists. Serious injury or death could result from contacting high voltage.



Mandatory Read Manual Action Symbol. (I.S.O. format) This symbol instructs personnel to read the Operators Manual before servicing or operating the equipment.



Mandatory Read Manual Action Symbol. This symbol instructs personnel to read the Operators Manual before servicing or operating the equipment.

Notice is used to notify people of important installation, operation or maintenance information which is not hazard related.

NOTICE

LOCKOUT / TAGOUT PROCEDURES

Lockout/Tagout is the placement of a lock/tag on an energy isolating device in accordance with an established procedure. When taking equipment out of service to perform maintenance or repair work, always follow the lockout/tagout procedures as outlined in ANSI Z344.1 and/or OSHA Standard 1910.147. This standard “requires employers to establish a program and utilize procedures for affixing appropriate lockout devices or tagout devices to energy isolating devices and to otherwise disable machines or equipment to prevent unexpected energizing, start-up, or release of stored energy in order to prevent injury to employees.”

HAZARD REVIEW

Electrocution Hazard



Electrocution accidents are most likely to occur during maintenance of the electrical system or when working on or near exposed high voltage wiring. This hazard does not exist when the electrical power has been disconnected, properly locked, and tagged out.

Automatic Start Hazard



This equipment may be controlled by an automated system and may start without warning. Failure to properly disconnect, lockout, and tagout all energy sources of remotely controlled equipment creates a very hazardous situation and could cause injury or even death. PLEASE STAY CLEAR AND BE ALERT.

YOU are responsible for the **SAFE** operation and maintenance of your USC, LLC equipment . **YOU** must ensure that you and anyone else who is going to operate, maintain or work around the equipment be familiar with the operating and maintenance procedures and related **SAFETY** information contained in this manual. This manual will take you step-by-step through your working day and alert you to good safety practices that should be adhered to while operating the equipment

Remember, **YOU** are the key to safety. Good safety practices not only protect you, but also the people around you. Make these practices a working part of your safety program. Be certain that **EVERYONE** operating this equipment is familiar with the recommended operating and maintenance procedures and follows all the safety precautions. Most accidents can be prevented. Do not risk injury or death by ignoring good safety practices.

- Equipment owners must give operating instructions to operators or employees before allowing them to operate the machine, and at least annually thereafter per OSHA (Occupational Safety and Health Administration) regulation 1928.57.
- The most important safety device on this equipment is a **SAFE** operator. It is the operator's responsibility to read and understand **ALL** Safety and Operating instructions in the manual and to follow them. All accidents can be avoided.
- A person who has not read and understood all operating and safety instructions is not qualified to operate the machine. An untrained operator exposes himself and bystanders to possible serious injury or death.
- Do not modify the equipment in any way. Unauthorized modification may impair the function and/or safety and could affect the life of the equipment.
- Think **SAFETY!** Work **SAFELY!**

GENERAL SAFETY

1. Read and understand the operator's manual and all safety labels before operating, maintaining, adjusting or unplugging the equipment .
2. Only trained persons shall operate the equipment . An untrained operator is not qualified to operate the machine.
3. Have a first-aid kit available for use should the need arise, and know how to use it.



LIW Dry Additive Feeder

4. Provide a fire extinguisher for use in case of an accident. Store in a highly visible place.
5. Do not allow children, spectators or bystanders within hazard area of machine.
6. Wear appropriate protective gear. This includes but is not limited to:
 - A hard hat
 - Protective shoes with slip resistant soles
 - Protective goggles
 - Heavy gloves
 - Hearing protection
 - Respirator or filter mask
7. Place all controls in neutral or off, stop motor, and wait for all moving parts to stop. Then disable power source before servicing, adjusting, repairing, or unplugging.
8. Review safety related items annually with all personnel who will be operating or maintaining the equipment.

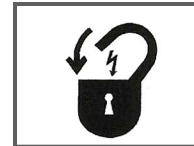

OPERATING SAFETY:

1. Read and understand the operator's manual and all safety labels before using.
2. Disconnect and disable electrical supply completely and wait for all moving parts to stop before servicing, adjusting, repairing or unplugging.
3. Clear the area of bystanders, especially children, before starting.
4. Be familiar with the machine hazard area. If anyone enters hazard area, shut down machine immediately. Clear the area before restarting.
5. Keep hands, feet, hair and clothing away from all moving and/or rotating parts.
6. Stay away from overhead obstructions and power lines during operation and transporting. Electrocution can occur without direct contact.
7. Do not operate machine when any guards are removed.
8. Inspect welds and repair if needed.

PLACEMENT SAFETY

1. Move only with the appropriate equipment
2. Stay away from overhead power lines when moving equipment. Electrocutation can occur without direct contact.
3. Be familiar with machine hazard area. If anyone enters hazard areas, shut down machine immediately. Clear the area before restarting.
4. Operate the equipment on level ground free of debris. Anchor the equipment to prevent tipping or upending.



Before placement of the equipment, be sure that ground is reasonably level. The equipment may topple or work improperly if the ground is too uneven, damaging the equipment and/or causing personal injury.

MAINTENANCE SAFETY

1. Review the operator's manual and all safety items before working with, maintaining or operating the equipment .
2. Place all controls in neutral or off, stop motors, disable power source, and wait for all moving parts to stop before servicing, adjusting, repairing or unplugging.
3. Follow good shop practices:
Keep service area clean and dry.
Be sure electrical outlets and tools are properly grounded.
Use adequate light for the job at hand.
4. Keep hands, feet, hair and clothing away from all moving and/or rotating parts.
5. Clear the area of bystanders, especially children, when carrying out any maintenance and repairs or making any adjustments.
6. Before resuming work, install and secure all guards when maintenance work is completed.
7. Keep safety labels clean. Replace any sign that is damaged or not clearly visible.



SAFETY LABELS

1. Keep safety labels clean and legible at all times.
2. Replace safety labels that are missing or have become illegible.
3. Replaced parts that displayed a safety label should also display the current label.
4. Replacement safety labels are available. Contact USC at (785) 431-7900 .

How to Install Safety Labels:

- Be sure that the installation area is clean and dry.
- Be sure temperature is above 50°F (10°C).
- Decide on the exact position before you remove the backing paper.
- Remove the smallest portion of the split backing paper.
- Align the sign over the specified area and carefully press the small portion with the exposed sticky backing in place.
- Slowly peel back the remaining paper and carefully smooth the remaining portion of the sign in place.
- Small air pockets can be pierced with a pin and smoothed out using the piece of sign backing paper.



Located on the USC equipment you will find safety labels. Always be sure to read and follow all directions on the labels.



Guards provided with USC equipment are to remain in place during operation.

Think **SAFETY!** Work **SAFELY!**

REMEMBER—If Safety Labels have been damaged, removed, become illegible, or parts replaced without safety labels, new labels must be applied. New safety labels are available from USC at (785) 431-7900.



09-02-0029



DANGER! RISK OF ELECTRIC SHOCK AND ARC FLASH

Avoid any alteration to the equipment. Alterations may produce dangerous situations, where serious injury or death may occur. This equipment shall be installed in accordance with local installation codes and applicable regulations which should be carefully followed in all cases. Authorities having jurisdiction should be consulted before installations are made. Owners/operators are responsible for knowing what requirements, hazards, and precautions exist with this equipment. Owners/operators are responsible for informing all personnel associated with the equipment and all who are in the general area of the equipment, the requirements, hazards, and precautions that exist with this equipment. Electrical equipment should be installed, operated, serviced, and maintained only by qualified personnel. A qualified person is one who has skills and knowledge related to the construction and operation of electrical equipment and its installation and has received safety training to recognize and avoid the hazards involved. Only appropriately trained persons who are familiar with and understand the contents of this manual and all other pertinent product documentation are authorized to work on and/or with this product. Owners/operators must ensure that all authorized persons have sufficient technical training, knowledge, and experience and be able to foresee and detect potential hazards that may be caused by using the product, by changing the settings and by the mechanical, electrical, and electronic equipment of the entire system in which the product is used. All persons working on and with the product must be fully familiar with all applicable standards, directives, and accident prevention regulations when performing such work. Servicing and maintaining the equipment should only occur if the equipment is deenergized and properly locked out and tagged out. If it is unfeasible to service or maintain the equipment while deenergized, the following standards shall be referenced to ensure safe practices are being followed and proper PPE is being used: 29 CFR § 1910.333 and 29 CFR § 1910.137. No responsibility is assumed by USC, LLC for any consequences arising out of the use of this material.



DANGER! RISQUE DE CHOC ÉLECTRIQUE ET D'ARC ÉLECTRIQUE

Évitez toute modification de l'équipement. Les modifications peuvent produire des situations dangereuses, pouvant entraîner des blessures graves ou la mort. Cet équipement doit être installé conformément aux codes d'installation locaux et aux réglementations applicables qui doivent être scrupuleusement respectés dans tous les cas. Les autorités compétentes doivent être consultées avant la réalisation des installations. Les propriétaires / opérateurs sont responsables de connaître les exigences, les dangers et les précautions associés à cet équipement. Les propriétaires / opérateurs sont responsables d'informer tout le personnel associé à l'équipement et tous ceux qui se trouvent dans la zone générale de l'équipement, les exigences, les dangers et les précautions qui existent avec cet équipement. L'équipement électrique doit être installé, utilisé, réparé et entretenu uniquement par du personnel qualifié. Une personne qualifiée est une personne qui possède des compétences et des connaissances liées à la construction et au fonctionnement du matériel électrique et à son installation et qui a reçu une formation en matière de sécurité pour reconnaître et éviter les risques encourus. Seules les personnes correctement formées qui connaissent et comprennent le contenu de ce manuel et toute autre documentation pertinente sur le produit sont autorisées à travailler sur et / ou avec ce produit. Les propriétaires / opérateurs doivent s'assurer que toutes les personnes autorisées ont une formation, des connaissances et une expérience techniques suffisantes et être en mesure de prévoir et de détecter les dangers potentiels pouvant être causés par l'utilisation du produit, en modifiant les paramètres et par les équipements mécaniques, électriques et électroniques de l'ensemble du système dans lequel le produit est utilisé. Toutes les personnes travaillant sur et avec le produit doivent être parfaitement familiarisées avec toutes les normes, directives et réglementations de prévention des accidents applicables lors de l'exécution de ces travaux. L'entretien et la maintenance de l'équipement ne doivent avoir lieu que si l'équipement est hors tension et correctement verrouillé et étiqueté. S'il est impossible de réparer ou d'entretenir l'équipement lorsqu'il est hors tension, les normes suivantes doivent être référencées pour s'assurer que les pratiques de sécurité sont suivies et que des EPI appropriés sont utilisés: 29 CFR § 1910.333 et 29 CFR § 1910.137. Aucune responsabilité n'est assumée par USC, LLC pour les conséquences découlant de l'utilisation de ce matériel.

INSTALLATION

SECTION B



HIGH VOLTAGE ~ Always disconnect the power source before working on or near the control panel or lead wires.



HIGH VOLTAGE ~ Use insulated tools when making adjustments while the controls are under power.



Permanent installation may require additional electrical cords, liquid hose, and air lines, since each installation is unique.



DO NOT modify any part of the Dry Additive Feeder, including the auger tube or add any mechanical device to attempt to change the way the product discharges from the end of the tube. This could pack the product tighter and change the flow rate of the product being added. It could also increase the pressure on the mechanical components of the drive assembly causing it to fail.

DO NOT leave product in the Dry Additive Feeder for extended periods of time as moisture could be absorbed causing the product to solidify. When the machine is started and the drive assembly is bound and unable to move, it will fail.

Failures caused by these actions will not be covered under the factory warranty (see page 31).

INSTALLING LIW DAF ON AT500

Use the following instructions below for installing the LIW DAF to an AT500 seed treater.

1. Remove the main assembly and mounting parts from the pallet.

NOTICE

If purchasing new AT500 with LIW DAF, the DAF will be mounted and In place.

2. Move your AT500 seed treater to a level working area.
3. Mount the stand to the front forklift pocket . Use the clamp and 3/8" bolts provided to secure the stand. Leave bolts loose for adjustments.
3. Adjust the feet on the stand so the upright is level.

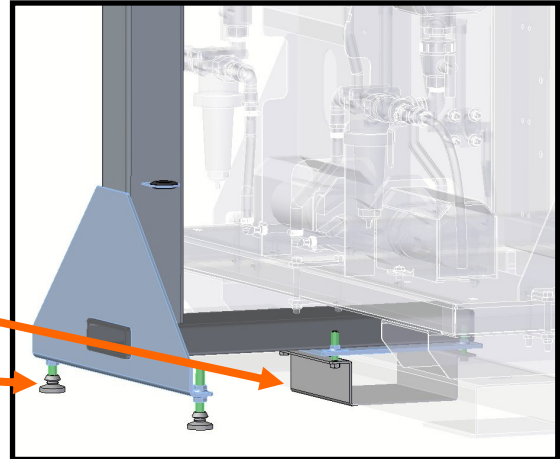

4. Install pipe adapter and funnel to auger.

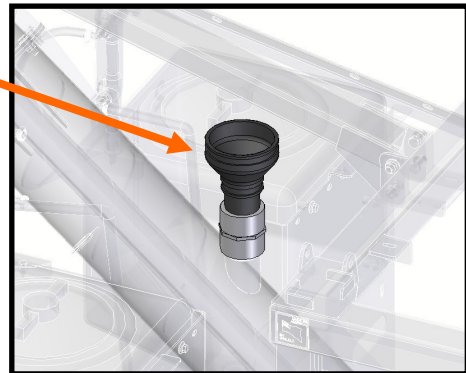

5. Flip over the auger support bar that is closest to the main control panel. This will allow a little extra room for the DAF to swing.

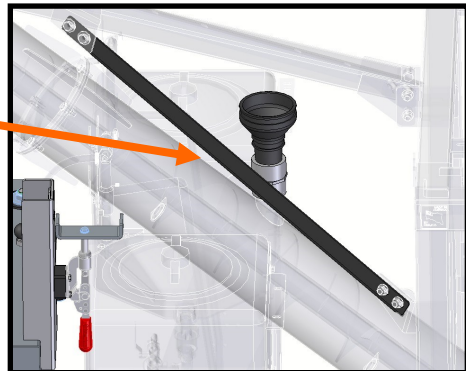

LIW Dry Additive Feeder

6. Install load cell to pivot using the metric bolts and lock washers provided. The cable on the load cell must face the same direction as shown on image to the right.

Load Cell Cable

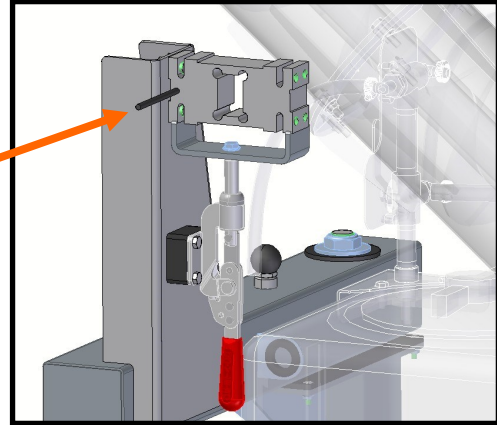

7. Mount the DAF to the other side of the load cell using the remaining 4 metric bolts and lock washers.

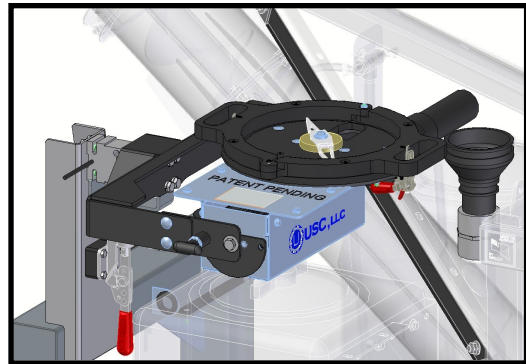

8. After the DAF has been mounted, swing the DAF around to ensure that there are no interferences. Ensure that the discharge end of the auger will allow product to dump into center of funnel.

9. Install the DAF control box. This will mount on the opposite side of the AT main control panel.

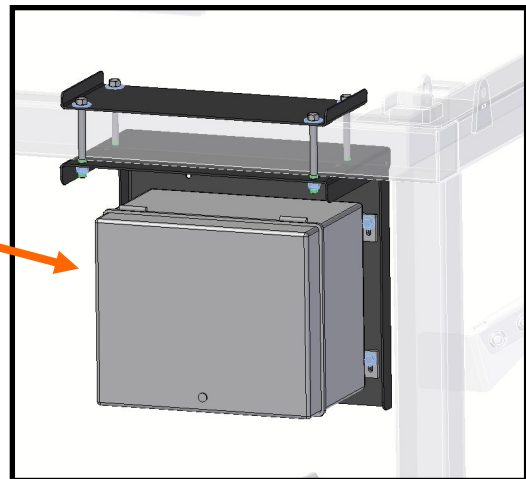

LIW Dry Additive Feeder

10. Connect the cable from the DAF motor to the DAF control panel.
11. Connect the cable from the DAF load cell to the DAF control panel.
12. Connect the communication cable (provided with DAF control panel), from the DAF panel to the M12 port labeled MODBUS-TCP on the AT500 main control panel.
(**see note 15 & 16 below if there is not an M12 MODBUS-TCP port on the AT500 main control panel**).

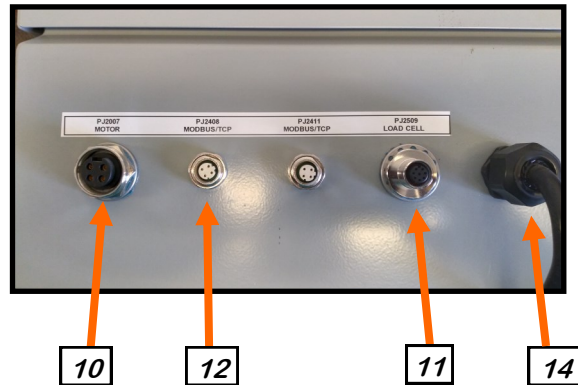

13. After cables are all connected, ensure that the DAF will swing around the full 90 degrees without any tension on the cables and ensure the DAF does not interfere with the AT500 framework.
14. Supply DAF control panel with a 120 Volt AC power source.
15. If the AT500 main control panel does not have an M12 port labeled MODBUS-TCP, install part# 03-06-0133 as shown below.
16. Install part# 03-07-0160 inside the control panel by connecting one end to the 03-06-0133. Connect the other end to port# 8 on the unmanaged ethernet switch located in the lower left hand corner of the control panel.

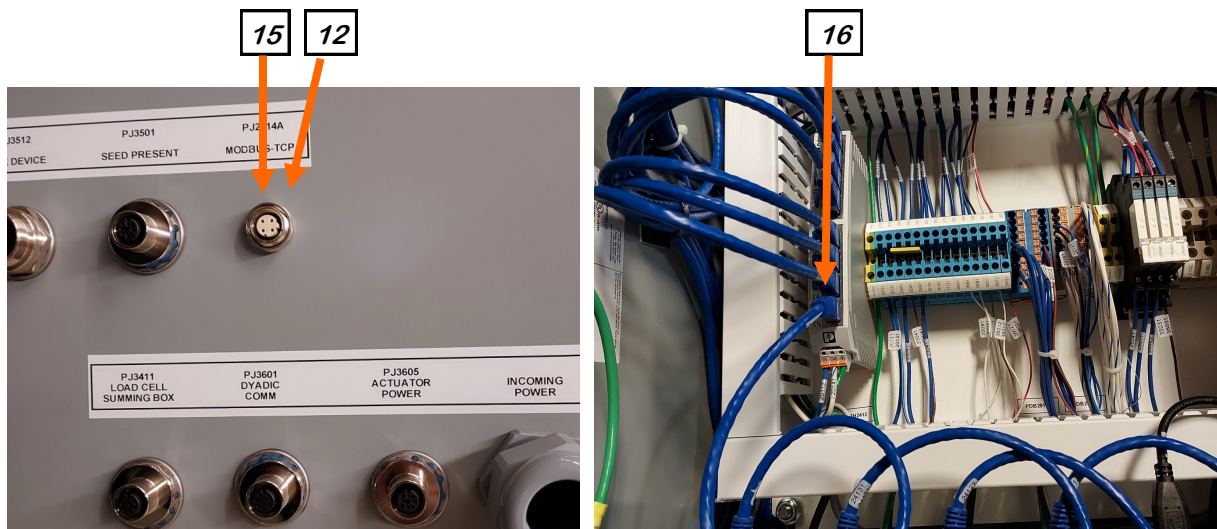

MECHANICAL OPERATION

LIW DRY ADDITIVE FEEDER OVERVIEW

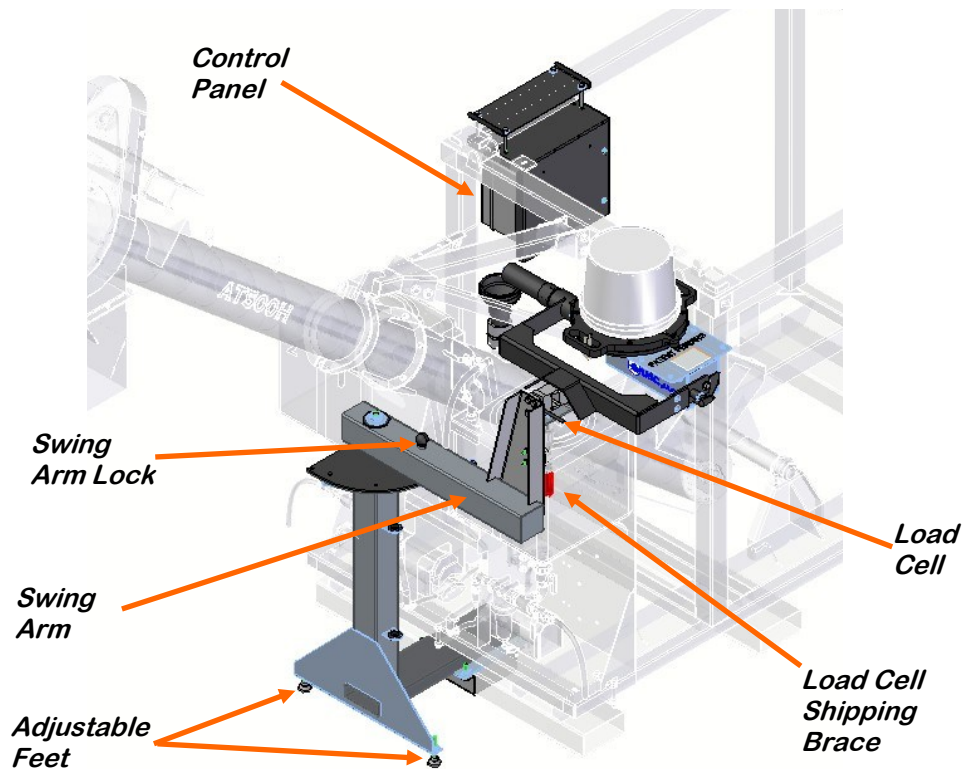
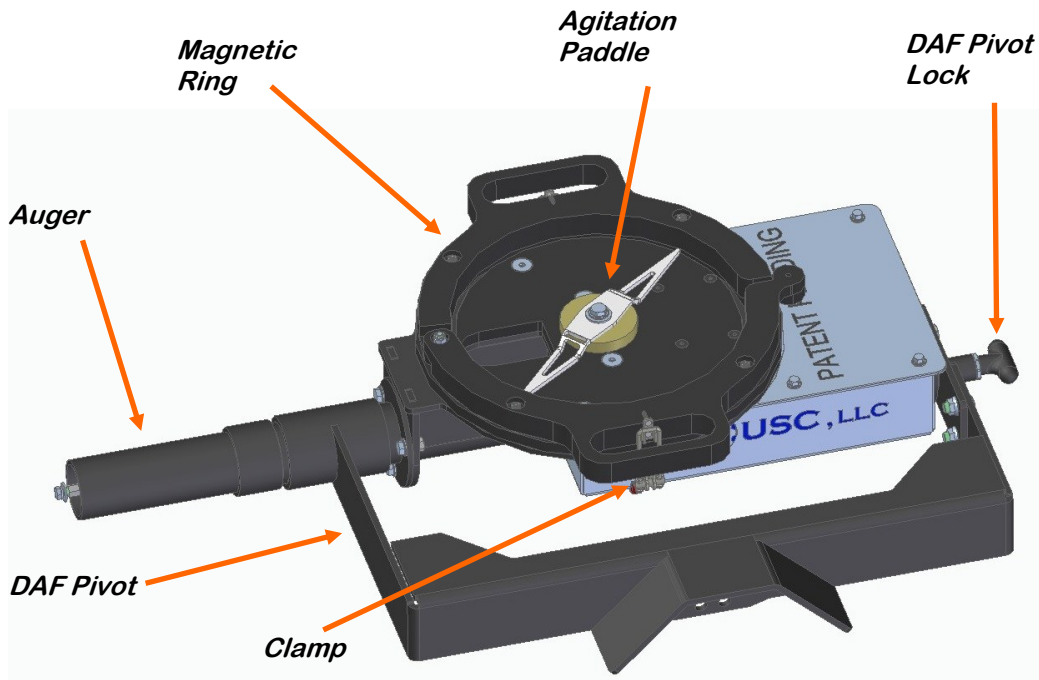

INSTALLING BUCKET WITH DRY PRODUCT.

Once the DAF has been properly mounted and everything has been tested without product, you can now install a bucket with dry product.

1. Remove the magnetic ring from the DAF

*Magnetic
Ring*

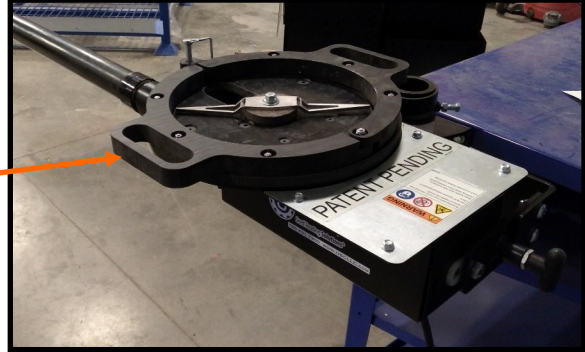

2. Attach magnetic ring to bucket which is provided by supplier of dry product.



3. Pull out on the DAF pivot lock. This will allow the DAF to rotate upside-down

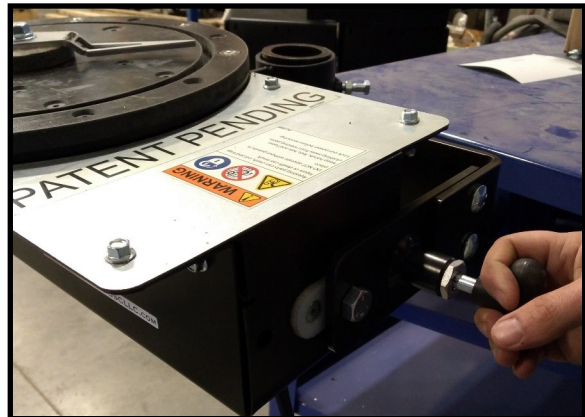

LIW Dry Additive Feeder

4. Rotate the DAF around to the upside-down position.



5. Attach magnetic ring with bucket back on DAF.

NOTICE Ensure that the ring is properly seated to the DAF to prevent leaking.

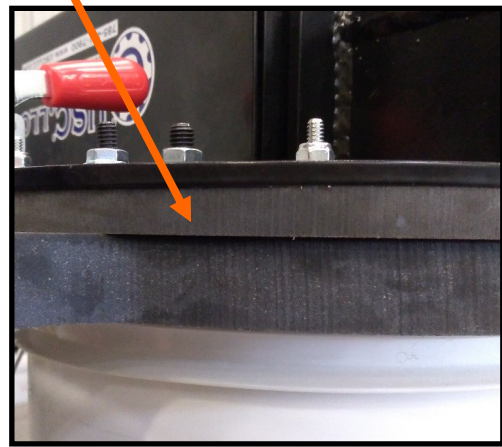
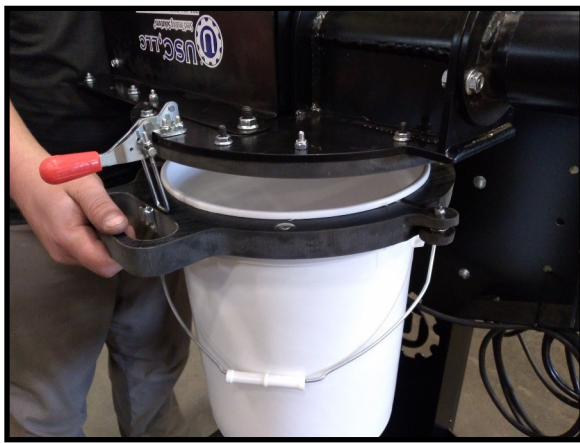

6. Secure the magnetic ring with bucket to the DAF using the two red handled clamps.

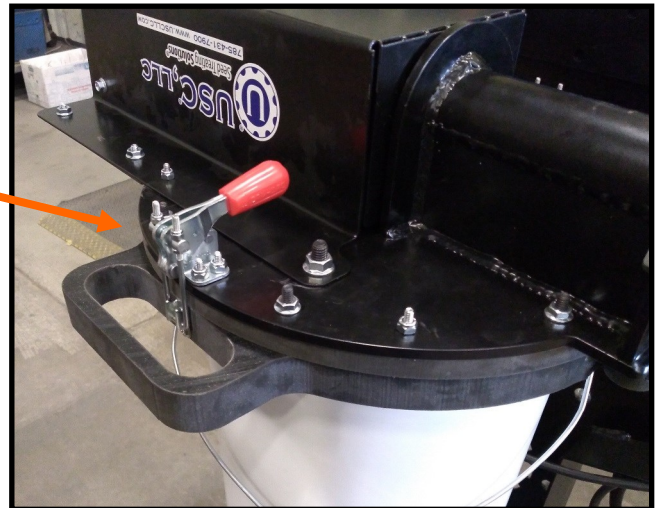

LIW Dry Additive Feeder

7. Pull the DAF pivot lock and rotate the DAF back upright to begin application.

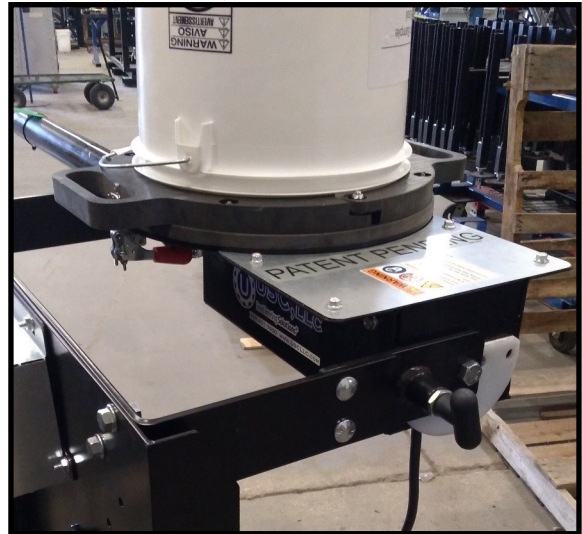

TRANSPORTING

When transporting or moving the AT500 with LIW DAF, follow these steps.

1. To avoid damage to the load cell when moving the AT500, move the red handle of the load cell shipping brace down. This will force the brace up against the load cell. (left picture)
2. When AT500 has been placed in position to begin operation, raise up the red handle to lower the brace down off the load cell. Failure to do this will cause inaccuracies during operation. (right picture)

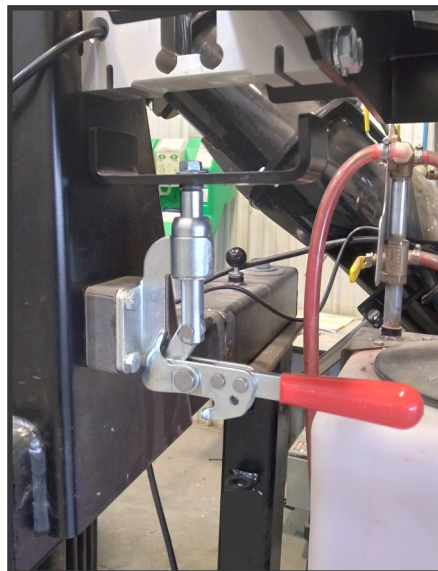
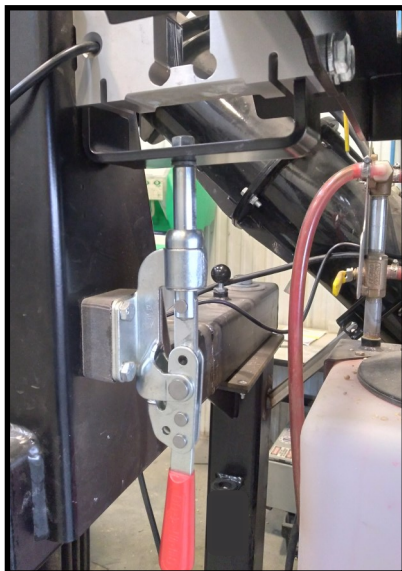

CALIBRATION

SECTION D

LOAD CELL CALIBRATION

Calibration of the DAF load cell is required for accurate application of dry product.



ELECTROCUTION HAZARD

Extra caution must be exercised when working inside the control panel when it is powered.

DANGEROUS VOLTAGES ARE PRESENT

1. Ensure the machine is placed on level ground.
2. Ensure the load cell lock is disengaged, and zero the scale weight.
3. Place a known weight (minimum 50 lbs. recommended) distributed evenly on the DAF where the bucket would attach.
4. Go to the main screen on the control panel. The "Scale Wt." for the DAF will show 50 lbs.
5. If the screen shows the correct weight, remove the weight(s) and store. If the screen does not show the correct weight, go to step 5 and re-calibrate the load cell.
6. Remove weights from the scale. With the DAF control panel powered on, open the panel door.

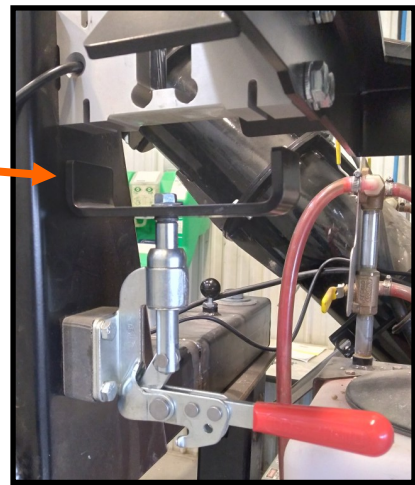

Face of unit

7. Remove the calibration screw on the scale indicator to gain access to the calibration switch.

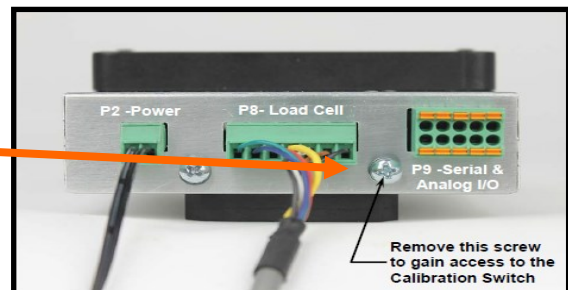

LOAD CELL CALIBRATION (CONTINUED)

8. Release the calibration switch to begin setup.
9. Press the F2/▲ key to step until the display shows CAL.
10. With CAL = displayed, press the F3/← key. The display will change to CAL=. Proceed to the CAL= (Perform Calibration) parameter.
11. With CAL= displayed, press the F3/← key. The display will change to no.
12. Press the F2/▲ key to toggle to YES and then press the F3/← key. The display will change to CAL 1=. Proceed to the CAL 1= parameter.
13. The display will show CAL 1 =. This is the first of two calibration weights. This weight is ZERO (NO LOAD).
14. Press the F3/← key to view the current setting.
15. Press the F3/← key again to set absolute zero.
16. Starting at the left and proceeding right, a series of dashes will appear and then disappear. Then the display will show CAL 2=.
17. This is the second of two calibration weights. This weight is with the recommended 50 lb. test weights or other known weight.
18. Press the F3/← key to view the current setting.
19. Use the F1/◀ and F2/▲ to input the value of the test weights. The display must read 0050.00, (it must match the known weight used for calibration).
20. Place 50lb. weight on the DAF where the bucket would attach, wait for the weight to stabilize on the scale indicator, then press the F3/← key.
21. Starting at the left and proceeding right, a series of dashes will appear and then disappear. Then the display will show F SPAn.
22. The calibration process is now complete. Press F1/◀ until you are returned to the starting screen.
23. Replace the screw removed in step 7.
24. Close and lock the control panel.
25. Remove and store the weights .

LIW DAF CALIBRATION

To properly calibrate the AutoSpeedMax value for a given product, setup the DAF with the correct product and a catch bucket or container. Using the HOA screen, run the DAF in Hand at 100% speed while watching the Flow Rate. Once the Flow Rate has become relatively stable and you can determine its average value, stop the DAF and go enter that value into the AutoSpeedMax field.

DAF Ingredient Assignment		
Clear	Ingredient Part# and Lot/SN	AutoSpeedMax (oz/min)
	<input type="text" value="Powder"/>	<input type="text" value="55.0"/>

AT500 program version 2.02.00 or newer is required to operate the LIW DAF. For full details on operation, see TD-09-06-1078 rev C or newer.

SECTION
E**TROUBLESHOOTING**

Below is a table describing the most frequent mechanical problems and solutions with the USC Dry Additive Feeder. For further assistance, contact USC at (785) 431-7900.

Problem	Possible Cause	Solution
Communications lost to DAF (Dry Additive Feeder) panel.	<ol style="list-style-type: none"> 1. Main control panel was power cycled several times without also power-cycling DAF panel. 2. DAF ethernet cable or power cable is disconnected. 	<ol style="list-style-type: none"> 1. Power-cycle DAF control panel. 2. Check communication and power cables to DAF control panel.
DAF Targeting is poor or otherwise not in an acceptable tolerance range.	<ol style="list-style-type: none"> 1. DAF is not calibrated for the currently assigned ingredient. 	<ol style="list-style-type: none"> 1. Follow the calibration instructions for the DAF to produce a quality calibration value for the DAF's AutoSpeedMax field.
DAF scale weight is inconsistent.	<ol style="list-style-type: none"> 1. Load cell lock might be engaged for travel/transport. 2. DAF framework or DAF auger might be coming in contact with treater frame or other obstruction/interference. 3. Scale head is not calibrated. 	<ol style="list-style-type: none"> 1. Check load cell lock. 2. Make sure DAF framework and DAF auger not touching anything. 3. Check scale head calibration.
DAF scale weight is not stable enough.	<ol style="list-style-type: none"> 1. With empty seed auger running, DAF scale movement range needs to be 0.04 lbs or less for best results. 	<ol style="list-style-type: none"> 1. Check for external influences like wind, vibration, trailer movement (make sure stabilizer jacks are engaged), etc.

MAINTENANCE

SECTION F

Proper maintenance of the Dry Additive Feeder is critical for peak performance, reliability and accuracy of this system. The following is a guideline for the type of maintenance and servicing that should be performed on this unit. Your environment and uses may require additional maintenance and service beyond this list to assure a reliable and safe unit. The operator of this unit has ultimate responsibility to identify areas of concern and rectify them before they become a hazard or safety issue. There is no substitute for a trained, alert operator.



Do not put this unit into operation with any questionably maintained parts. Poor performance or a hazard may occur.

GREASING

Use an SAE multipurpose high temperature grease with extreme pressure (EP) performance. Also acceptable is an SAE multipurpose lithium-based grease.

1. Use a Maintenance Checklist to keep record of all scheduled maintenance.
2. Use a hand-held grease gun for all greasing.
3. Wipe grease fitting with a clean cloth before greasing to avoid injecting dirt and grit.
4. Replace and repair broken fittings immediately.



If fittings will not take grease, remove and clean thoroughly. Also clean lubricant passageway. Replace fitting if necessary.

BEARING AND GEARS

1. Turn the DAF upside-down. Remove the bottom cover to access the bearing.

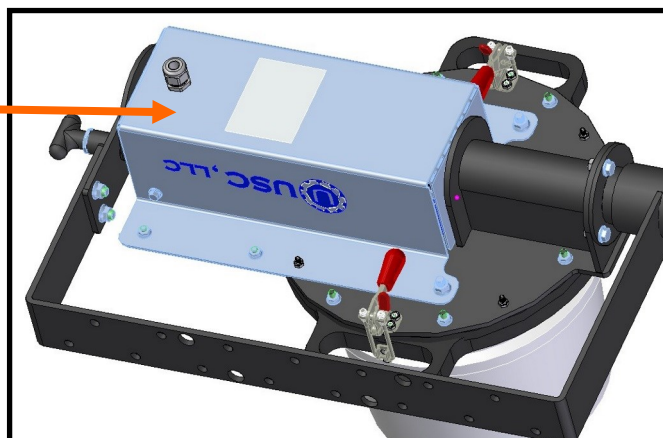

LIW Dry Additive Feeder

2. Inspect the pillow block bearing and grease once a year at the end of the treating season or when storing the machine.
3. Check gear alignment and adjust if necessary.

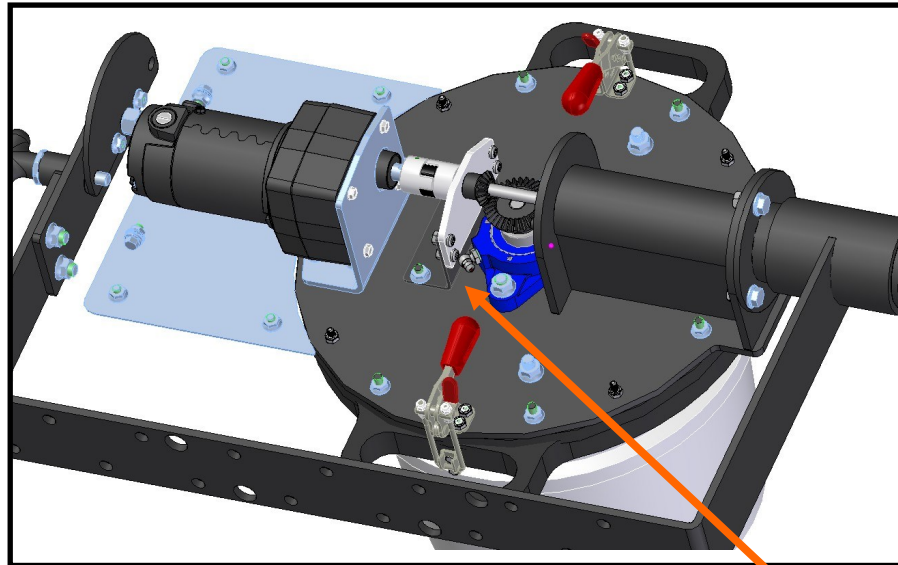

*90 Degree
Grease Fitting*

SUPPLY HOPPER

1. Periodically clean out any build up of dry material in the hopper.
2. Check the stir arm for wear, breaks or loose fastener.
3. Check auger for wear or breaks.

ELECTRICAL PANEL

1. Check quick connects on end of Motor Control cord.
2. Check and tighten wire connections.
3. Check power cords for cuts or frays and ensure ground is present.

When storing the Dry Additive Feeder for long periods of time, the following procedure must be followed to reduce the chance of rust, corrosion and fatigue of the equipment. You can also use these steps when storing the machine for the winter.



A dust mask and protective rubber gloves shall be used when cleaning the machine.

1. Disconnect power to the machine.
2. Remove auger tube and clean the auger (compressed air may be used). Then reinstall the auger tube.
3. Clean out the supply hopper of any debris (compressed air may be used).
4. After the machine is thoroughly cleaned, grease the bearing as directed in the maintenance section.
5. Store the machine inside a protective building to keep it from being exposed to the weather.
6. Cover the Dry Additive Feeder with a tarpaulin to keep dust and dirt out of the machine.

LIW Dry Additive Feeder

NOTES:

LIMITED WARRANTY

SECTION H

USC, LLC, MANUFACTURER WARRANTY ON SEED TREATING EQUIPMENT

01AUG22

USC, LLC, (Manufacturer) warrants its equipment as follows:

1.Limited Warranty: Manufacturer warrants that the Products sold hereunder will be free from defects in material and workmanship for a period of 18 months from date of shipment by Manufacturer for all seed treating equipment and a period of 12 months from date of shipment by Manufacturer for all grain and fertilizer handling equipment.

If the Products do not conform to this Limited Warranty during the warranty period, Buyer shall notify Manufacturer in writing (on the approved USC warranty claim form) of the claimed defects and demonstrate to Manufacturer satisfaction that said defects are covered by this Limited Warranty (through pictures, video or other objective data). If the defects are properly reported to Manufacturer within the warranty period, and the defects are of such type and nature as to be covered by this warranty, Manufacturer shall, at its expense, furnish replacement Products or, at Manufacturer's option, replacement parts for the defective products. Shipping and installation of the replacement Products or replacement parts shall be at the Buyer's expense.

All replacement parts orders through Manufacturer will carry their specific manufacturer's standard warranty. There is no warranty on replacement parts manufactured by Manufacturer. Manufacturer will not extend any warranty due to replaced parts. The end user is responsible for all shipping and handling expenses for parts returned to Manufacturer under this section which may or may not be included in that specific warranty. Manufacturer will pay shipping expense between USC and its vendor.

2.Other Limits: THE FOREGOING IS IN LIEU OF ALL OTHER WARRANTIES, EXPRESSED OR IMPLIED, INCLUDING BUT NOT LIMITED TO THE IMPLIED WARRANTIES OF MERCHANTABILITY AND FITNESS FOR A

PARTICULAR PURPOSE. Manufacturer does not warrant against damages or defects arising from improper installation (where installation is by persons other than Manufacturer), against defects in products or components not manufactured by Manufacturer, or against damages resulting from such non-Manufacturer made products or components. Manufacturer passes on to the Buyer the warranty it received (if any) from the maker of such non-Manufacturer made products or components. This warranty also does not apply to Products upon which repairs and / or modifications have been affected or attempted by persons other than pursuant to written authorization by Manufacturer. This includes any welding on equipment which could damage electrical components. Manufacturer does not warrant against injuries or damages resulting from misuse and / or abuse of Products, improper storage or handling, acts of nature, effects of weather, including effects of weather due to outside storage, accidents, or damages incurred during transportation by common carrier or Dealer/customer arranged freight. Any replacement or repair covered under this warranty will not extend the warranty period. The remainder of the manufacturer's warranty will remain in force until stated expiration.

3.Exclusive Obligation: THIS WARRANTY IS EXCLUSIVE. The sole and exclusive obligation of Manufacturer shall be to repair or replace the defective Products in the manner and for the period provided above. Manufacturer shall not have any other obligation with respect to the Products or any part thereof, whether based on contract, tort, strict liability or otherwise. Under no circumstances, whether based on this Limited Warranty or otherwise, shall Manufacturer be liable for lost profits, lost revenue, lost sales (whether direct or indirect damages), incidental, special, punitive, indirect or consequential damages. Buyer shall make no claims for remuneration for any loss as a result of USC equipment and USC shall reject any and all claims that may arise as stated herein.

4.Other Statements: Manufacturer's employees or representatives' oral or other written statements do not constitute warranties, shall not be relied upon by Buyer, and are not a part of the contract for sale or this limited warranty. The USC Warranty Manager is the final decision point for all warranty claims.

5.Return Policy: Approval is required prior to returning goods to Manufacturer irrespective of warranty claim. Manufacturer may give a credit, less a 15% restocking fee, for goods that are returned in new, sellable condition. Items returned for warranty that are found to be not covered by the warranty will remain the property of the Buyer. The Buyer will have the ability to have part returned at their expense or, if in new, sellable condition, receive a credit less a 15% restocking fee and less any USC paid freight for its return.

6.Entire Obligation: This Limited Warranty states the entire obligation of Manufacturer with respect to the Products. If any part of this Limited Warranty is determined to be void or illegal, the remainder shall remain in full force and effect. Other terms included in Manufacturer's Terms of Sale will also apply.

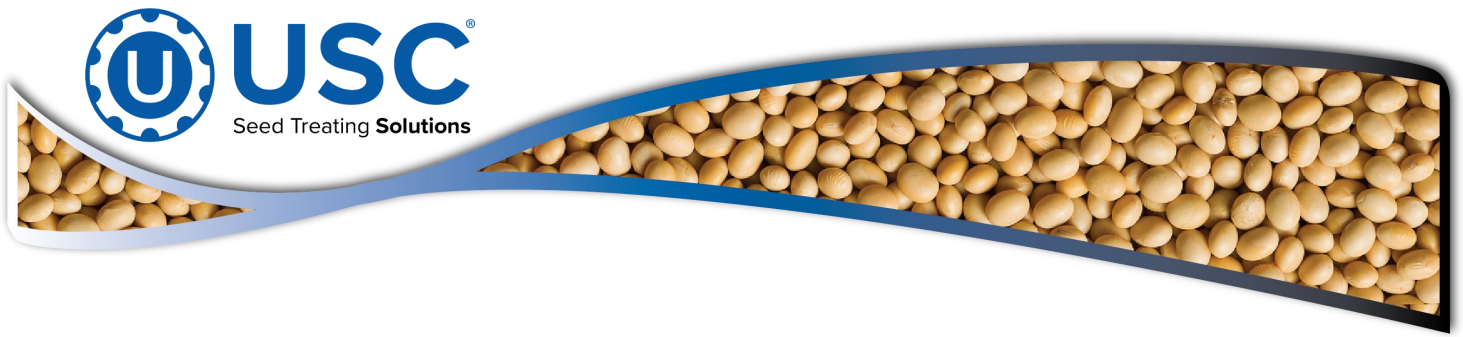

USC LLC

2320 124th Road

Sabetha, KS 66534

PHONE: (785) 431-7900

EMAIL: sales-team@uscllc.com

WEB: www.uscllc.com
